

(19)



(11)

**EP 3 896 289 B1**

(12)

**EUROPEAN PATENT SPECIFICATION**

(45) Date of publication and mention of the grant of the patent:

**26.07.2023 Bulletin 2023/30**

(51) International Patent Classification (IPC):

**F04D 29/28<sup>(2006.01)</sup> F04D 29/68<sup>(2006.01)</sup>**

(21) Application number: **21154990.2**

(52) Cooperative Patent Classification (CPC):

**F04D 29/281; F04D 29/681; F05D 2250/294**

(22) Date of filing: **03.02.2021**

**(54) IMPELLER AND CENTRIFUGAL FAN INCLUDING THE SAME**

LAUFRAD UND ZENTRIFUGALGEBLÄSE DAMIT

TURBINE ET VENTILATEUR CENTRIFUGE LE COMPRENANT

(84) Designated Contracting States:

**AL AT BE BG CH CY CZ DE DK EE ES FI FR GB GR HR HU IE IS IT LI LT LU LV MC MK MT NL NO PL PT RO RS SE SI SK SM TR**

• **Tsai, Chi-Tsung**

**Kaohsiung City, Taiwan (R.O.C.) (TW)**

• **Tang, Chung-Yen**

**Kaohsiung City, Taiwan (R.O.C.) (TW)**

(30) Priority: **17.04.2020 TW 109113025**

(74) Representative: **Louis Pöhlau Lohrentz**

**Patentanwälte**

**Merianstrasse 26**

**90409 Nürnberg (DE)**

(43) Date of publication of application:

**20.10.2021 Bulletin 2021/42**

(73) Proprietor: **Sunonwealth Electric Machine Industry Co., Ltd.**

**Kaohsiung City / Taiwan, R.O.C. (TW)**

(56) References cited:

**EP-A1- 3 101 280**

**WO-A1-2011/121943**

**US-A1- 2009 255 654**

**US-A1- 2015 369 073**

(72) Inventors:

• **Horng, Alex**

**Kaohsiung City, Taiwan (R.O.C.) (TW)**

**EP 3 896 289 B1**

Note: Within nine months of the publication of the mention of the grant of the European patent in the European Patent Bulletin, any person may give notice to the European Patent Office of opposition to that patent, in accordance with the Implementing Regulations. Notice of opposition shall not be deemed to have been filed until the opposition fee has been paid. (Art. 99(1) European Patent Convention).

## Description

### BACKGROUND OF THE INVENTION

#### 1. Field of the Invention

**[0001]** The present invention relates to an impeller and a fan including the impeller and, more particularly, to an impeller with reduced operational noise and improved fan efficiency and a centrifugal fan including the impeller.

#### 2. Description of the Related Art

**[0002]** FIG. 1 shows a conventional impeller 9 including a hub 91, an extension disc 92, a plurality of blades 93, and an air guiding cover 94. The extension disc 92 is connected to the hub 91. The plurality of blades 93 is connected to the extension disc 92 and the air guiding cover 94. An example similar to the conventional impeller 9 is disclosed in Taiwan Patent No. 1653397 and EP3101280 A1.

**[0003]** Although the above conventional impeller 9 has improved airflow guiding smoothness and lower operational noise in comparison with traditional impellers, the air guiding cover 94 is essentially in the form of a board with a uniform thickness and flat inner and outer faces, resulting in a lower structural strength. Furthermore, reducing the operational noise of the above conventional impeller 9 is also required.

**[0004]** US 2015/369073 A1 discloses a micropump structure comprising: a rotatable impeller and a stationary impeller shroud. The rotatable impeller is rotatably disposed within the stationary impeller shroud. The stationary impeller shroud has a plurality of flow-guiding channels configured to guide a flow angle of a secondary flow to be consistency with a main flow.

### SUMMARY OF THE INVENTION

**[0005]** To solve the above-mentioned problems, it is an objective of the present invention to provide an impeller and a centrifugal fan including the impeller, which can further increase the airflow smoothness, thereby reducing the operational noise without reducing the air volume.

**[0006]** It is another objective of the present invention to provide an impeller and a centrifugal fan including the impeller, which can increase the structural strength of an air guiding cover.

**[0007]** It is a further objective of the present invention to provide an impeller and a centrifugal fan including the impeller, which can further increase the fan performance and the fan efficiency.

**[0008]** It is still another objective of the present invention to provide an impeller and a centrifugal fan including the impeller, which can increase the yield.

**[0009]** As used herein, the term "a" or "an" for describing the number of the elements and members of the present invention is used for convenience, provides the

general meaning of the scope of the present invention, and should be interpreted to include one or at least one. Furthermore, unless explicitly indicated otherwise, the concept of a single component also includes the case of plural components.

**[0010]** As used herein, the term "coupling", "engagement", "assembly", or similar terms is used to include separation of connected members without destroying the members after connection or inseparable connection of the members after connection. A person having ordinary skill in the art would be able to select according to desired demands in the material or assembly of the members to be connected.

**[0011]** An impeller according to the present invention includes a hub, an extension disc connected to the hub, and a plurality of blades disposed annularly around the hub. Each of the plurality of blades has a bottom edge connected to the extension disc. An air guiding cover is connected to top edges of the plurality of blades. The air guiding cover includes an air inlet edge which encircles and delimits an air inlet. The air guiding cover further includes an air outlet edge. A plurality of air outlets is formed between the air outlet edge of the air guiding cover and an outer edge of the extension disc and is separated from each other by the plurality of blades. The air guiding cover further includes an inner face having a plurality of grooves. Each two adjacent blades have at least one of the plurality of grooves therebetween. Each groove extends from a respective air outlet towards the air inlet. A width of each groove decreases from the respective air outlet towards the air inlet.

**[0012]** A centrifugal fan according to the present invention includes a base including a shaft coupling portion, a stator disposed around the shaft coupling portion, and the above-mentioned impeller. The hub is coupled to a shaft rotatably mounted to the shaft coupling portion. A magnetic member is disposed peripherally around the shaft and is aligned with the stator.

**[0013]** The impeller and the centrifugal fan according to the present invention increase the airflow guiding smoothness by the arrangement of the inner face of the air guiding cover, which not only further increase the fan performance and efficiency but also reduces the operational noise. Furthermore, the structural strength of the air guiding cover is also increased, such that the air guiding cover is less likely to deform during formation or operation, thereby increasing the yield.

**[0014]** Each groove includes an inner end and an outer end. The inner end of each groove is located between the air inlet edge and the air outlet edge of the air guiding cover. The outer end of each groove is located on the air outlet edge of the air guiding cover. Thus, the width of each groove is maximal at the respective air outlet, increasing the airflow guiding smoothness.

**[0015]** Each groove includes two sides connected to the inner end and the outer end. Each of the two sides extends rectilinearly from the inner end to the outer end. Thus, the airflow guiding smoothness is increased.

**[0016]** In an example, the air inlet edge and the air outlet edge of the air guiding cover have a radial spacing therebetween. Each air outlet includes a front side and a rear side behind the front side with respect to a rotating direction. One of the two sides of each groove adjacent to the front side of the respective air outlet has a rectilinear distance between the inner end and the outer end. The rectilinear distance is 0.8-2 times the radial spacing. Thus, each groove can have an adequate length to increase the airflow guiding smoothness and to reduce the operational noise.

**[0017]** In an example, a width of each air outlet is 2-8 times the width of each groove at the respective air outlet. Thus, each groove can have an adequate width at the respective air outlet to increase the airflow guiding smoothness and to reduce the operational noise.

**[0018]** In an example, each air outlet includes a front side and a rear side behind the front side with respect to a rotating direction. A width from the front side to one of the two sides of each groove nearest to the front side is 1-3 times the width of each groove at the respective air outlet. Thus, each groove can be located in a proper location to increase the airflow guiding smoothness and to reduce the operational noise.

**[0019]** In an example, each air outlet includes a front side and a rear side behind the front side with respect to a rotating direction. A height in at least a portion of each air outlet decreases from the front side towards the rear side of the air outlet. Thus, the air velocity towards the rear side of respective air outlet can be increased, improving the fan performance.

**[0020]** In an example, the inner face of the air guiding cover includes a plurality of arcuate guiding portions respectively corresponding to the plurality of air outlets. Each arcuate guiding portion is contiguous to the rear side of the respective air outlet and has a peak. The height in a portion of each air outlet without the groove increases from the peak towards the front side of the air outlet and increases from the peak towards the rear side of the air outlet. Thus, the airflow can be guided outwards more smoothly to further reduce the operational noise.

**[0021]** In an example, the air guiding cover includes an outer face having a plurality of recessed portions aligned with the plurality of arcuate guiding portions, respectively. Thus, the structural strength and the yield in formation of the air guiding cover can be increased.

**[0022]** In an example, each two adjacent blades have at least two grooves therebetween. This more obviously increases the airflow guiding smoothness and reduces the operational noise.

**[0023]** In an example, the grooves in the same air outlet have the same width at the air outlet. This more obviously increases the airflow guiding smoothness and reduces the operational noise.

**[0024]** In an example, the inner face of the air guiding cover includes at least one protruding portion contiguous to one of the two sides of a respective groove. An outer face of the air guiding cover includes at least one re-

cessed portion aligned with the at least one protruding portion. Thus, the structural strength and the yield in formation of the air guiding cover can be increased.

**[0025]** In an example, the air guiding cover includes a flange connected to the air outlet edge of the air guiding cover. Thus, the structural strength of the air guiding cover can be increased, such that each air outlet is less likely to deform.

## 10 BRIEF DESCRIPTION OF THE DRAWINGS

**[0026]** The present invention will become clearer in light of the following detailed description of illustrative embodiments of this invention described in connection with the drawings.

FIG. 1 is a perspective view of a conventional impeller.

FIG. 2 is a perspective view of an impeller of a preferred embodiment according to the present invention.

FIG. 3 is a cross sectional view taken along section line 3-3 of FIG. 2.

FIG. 4 is a cross sectional view taken along section line 4-4 of FIG. 3.

FIG. 5 is a cross sectional view taken along section line 5-5 of FIG. 3.

FIG. 6 is a cross sectional view of a centrifugal fan of a preferred embodiment according to the present invention.

FIG. 7 is a graph illustrating differences between the impeller of the preferred embodiment according to the present invention and the conventional impeller in the air volume, air pressure and the fan efficiency.

**[0027]** When the terms "front", "rear", "left", "right", "up", "down", "top", "bottom", "inner", "outer", "side", and similar terms are used herein, it should be understood that these terms have reference only to the structure shown in the drawings as it would appear to a person viewing the drawings and are utilized only to facilitate describing the invention, rather than restricting the invention.

## 45 DETAILED DESCRIPTION OF THE INVENTION

**[0028]** With reference to FIG. 2, an impeller **F** of an embodiment according to the present invention includes a hub 1, an extension disc 2, a plurality of blades 3 and an air guiding cover 4. The extension disc 2 is connected to the hub 1. The plurality of blades 3 is connected to the extension disc 2 and the air guiding cover 4.

**[0029]** Please refer to FIGs. 2 and 3, while the type of the hub 1 is not limited in the present invention. In this embodiment, the hub 1 includes a disc body 11 and an annular wall 12. The annular wall 12 is connected to a periphery of the disc body 11 and extends axially.

**[0030]** The extension disc 2 can be annular and in-

cludes an inner edge 2a and an outer edge 2b. The inner edge 2a of the extension disc 2 can be directly or indirectly connected to the annular wall 12 of the hub 1. The extension disc 2 includes a first face 21 and a second face 22 opposite to the first face 21. The extension disc 2 can have a higher central portion and a lower peripheral portion, such that the inner edge 2a of the extension disc 2 can be higher than the outer edge 2b of the extension disc 2. Furthermore, the first face 21 encircles and delimits an assembling space **S** below the hub 1.

**[0031]** The plurality of blades 3 is disposed annularly around the hub 1. Each of the plurality of blade 3 includes a bottom edge 3a and a top edge 3b opposite to the top edge 3b. The bottom edges 3a of the plurality of blades 3 is connected to the extension disc 2, for instance, to the second face 22 of the extension disc 2. The air guiding cover 4 is connected to the top edges 3b of the plurality of blades 3.

**[0032]** The air guiding cover 4 includes an inner face 41 and an outer face 42 opposite to the inner face 41. The air guiding cover 4 is connected, for instance, by the inner face 41, to the top edges 3b of the plurality of blades 3. The air guiding cover 4 includes an air inlet edge 4a which encircles and delimits an air inlet T1. The air guiding cover 4 further includes an air outlet edge 4b. A plurality of air outlets T2 is formed between the air outlet edge 4b of the air guiding cover 4 and the outer edge 2b of the extension disc 2 and is separated from each other by the plurality of blades 3. Thus, airflow can enter via the air inlet T1 and then guided by the plurality of blades 3 to exit via the plurality of air outlets T2, providing a centrifugal airflow guiding pattern in which air enters axially and leaves laterally.

**[0033]** With reference to FIGs. 2 and 4, the inner face 41 of the air guiding cover 4 can be non-planar, such that different locations of the inner face 41 have difference distances to the second face 22 of the extension disc 2. Namely, the height **H** is not uniform at different locations of each air outlet T2. Each air outlet T2 includes a front side E1 and a rear side E2 behind the front side E1 with respect to the rotating direction. A height **H** in at least a portion of each air outlet T2 decreases from the front side E1 towards the rear side E2 of the air outlet T2, thereby increasing the air velocity.

**[0034]** With reference to FIGs. 2 and 5, the inner face 41 of the air guiding cover 4 includes a plurality of grooves 43. Each two adjacent blades 3 have at least one groove 43 therebetween for reducing the operational noise. More specifically, each groove 43 includes an inner end 431 and an outer end 432. Each groove 43 further includes two sides 433 connected to the inner end 431 and the outer end 432, respectively. The inner end 431 is located between the air inlet edge 4a and the air outlet edge 4b of the air guiding cover 4. The outer end 432 of each groove 43 is located on the air outlet edge 4b of the air guiding cover 4. Each groove 43 extends from the respective air outlet T2 towards the air inlet T1. A width W1 of each groove 43 decreases from the respective air out-

let T2 towards the air inlet T1. Namely, each groove 43 may only include a portion having a wider outer side and a narrower inner side. Alternatively, as shown in this embodiment, the width W1 of each groove 43 continuously decreases from the outer end 432 towards the inner end 431, such that the width W1 of the groove 43 is maximal at the respective air outlet T2.

**[0035]** Furthermore, the air inlet edge 4a and the air outlet edge 4b of the air guiding cover 4 have a radial spacing D1 therebetween. One of the two sides 433 of each groove 43 adjacent to the front side E1 of the respective air outlet T2 has a rectilinear distance D2 between the inner end 431 and the outer end 432. The rectilinear distance D2 is about 0.8-2 times the radial spacing D1, such that each groove 43 has an adequate length. Furthermore, a width W2 of each air outlet T2 is about 2-8 times the width W1 of each groove 43 at the respective air outlet T2, such that each groove 43 has an adequate width at the respective air outlet T2. A width W3 from the front side E1 of each air outlet T2 to one of the two sides 433 of the respective groove 43 nearest to the front side E1 is about 1-3 times the width W1 of the respective groove 43 at the respective air outlet T2, such that each groove 43 can be located at a proper location.

**[0036]** Furthermore, each of the two sides 433 of each groove 43 extends rectilinearly from the inner end 431 to the outer end 432. Alternatively, each of the two sides 433 of each groove 43 has a portion extending rectilinearly to an extent which is at least one half of the rectilinear distance D2, increasing the airflow guiding smoothness. The number of the grooves 43 between each two adjacent blades 3 may be two or more to achieve a better noise reducing effect. The numbers of grooves 43 in different air outlets T2 can be identical or different. The grooves 43 in the same air outlet T2 may have the same width W1 at the air outlet T2.

**[0037]** With reference to FIGs. 2 and 4 again, the inner face 41 of the air guiding cover 4 may include at least one protruding portion **P** contiguous to one of the two sides 433 of the respective groove 43. The outer face 42 of the air guiding cover 4 may include at least one recessed portion 44 aligned with the at least one protruding portion **P**. By providing the at least one recessed portion 44, the air guiding cover 4 can have an increased structural strength and is, thus, less likely to deform. In an air guiding cover 4 made by injection molding, a thickness of the air guiding cover 4 at the protruding portion **P** is approximately the same as a thickness of portions adjacent to the protruding portion **P**, providing a substantially same cooling and hardening speed thereof. This avoids deformation resulting from much difference in the cooling and hardening speed at different portions of the air guiding cover 4. Furthermore, the amount of material used for forming the protruding portion **P** can be reduced to thereby reduce the manufacturing costs.

**[0038]** The inner face 41 of the air guiding cover 4 may further include a plurality of arcuate guiding portions 45 respectively corresponding to the plurality of air outlets

T2. Each arcuate guiding portion 45 may be contiguous to the rear side E2 of the respective air outlet T2, such that airflow can be smoothly guided outwards, further reducing the operational noise. An arcuate face formed by each arcuate guiding portion 45 can have a peak 451 nearest to the second face 22 of the extension disc 2. The height H in a portion of each air outlet T2 without the groove 43 increases from the peak 451 towards the front side E1 of the air outlet T2 and increases from the peak 451 towards the rear side E2 of the air outlet T2. Each arcuate guiding portion 45 is more adjacent to the rear side E2 of the respective air outlet T2 and, thus, can be in the form of a protrusion. Preferably, the air guiding cover 4 may have recessed portions 44 formed on the outer face 42, with each recessed portion 44 aligned with the respective arcuate guiding portion 45. The air guiding cover 4 may further include a flange 46 connected to and protruding from the outer face 42 of the air guiding cover 4. Preferably, the flange 46 is connected to the air outlet edge 4b of the air guiding cover 4. Thus, the structural strength of the air guiding cover 4 can be increased, such that each air outlet T2 is less likely to deform.

**[0039]** With reference to FIGs. 2 and 6, by the above structure, the impeller F according to the present invention is coupled to a shaft 5 by the hub, for instance, by the disc body 11 of the hub 1. A magnetic member 6 is disposed peripherally around the shaft 5. The magnetic member 6 can be directly or indirectly coupled to the annular wall 12 of the hub 1. Then, a centrifugal fan can be formed by further assembly with a base 7 and a stator 8.

**[0040]** More specifically, the base 7 can include a positioning casing 7a and a bottom casing 7b. The positioning casing 7a can envelope the stator 8 by injection, providing necessary insulation. Furthermore, the positioning casing 7a can form a shaft coupling portion 71 for assembly with at least one bearing 72. The shaft 5 is rotatably mounted in the bearing 72. The stator 8 is disposed around the shaft coupling portion 71. The magnetic member 6 faces the stator 8 for magnetic induction. The bottom casing 7b can be assembled to a bottom of the positioning casing 7a and is substantially in the assembling space S of the extension disc 2. Thus, when the stator 8 is energized to create a magnetic field for driving the impeller F to rotate, airflow entered via the air inlet T1 can be affected by the grooves 43, the protruding portions P, or the arcuate guiding portions 45 while passing through the plurality of blades 3, thereby increasing the airflow flowing smoothness. Thus, the airflow can flow out of the plurality of air outlets T2 more smoothly, such that the operational noise of the centrifugal fan can be sufficiently reduced.

**[0041]** To prove the above effect, an impeller F of the above preferred embodiment according to the present invention is compared with the conventional impeller shown in FIG. 1, making only the type of the impeller as the variable to proceed tests of air volume, air pressure, fan efficiency and operational noise. As shown in FIG. 7, as compared to the conventional impeller, the impeller F

of the preferred embodiment according to the present invention has better fan performance and efficiency. Furthermore, in the noise test, when the operational noise of both the impeller F of the preferred embodiment according to the present invention and the conventional centrifugal fan reaches about 82dBA, the air volume, air pressure and fan efficiency of the impeller F of the preferred embodiment according to the present invention are better than those of the conventional centrifugal fan. Thus, given the same requirement in the fan performance and efficiency, the impeller F of the preferred embodiment according to the present invention can obviously achieve the effect of reduced operational noise.

**[0042]** In view of the foregoing, the impeller and the centrifugal fan according to the present invention increase the airflow guiding smoothness by the arrangement of the inner face of the air guiding cover, which not only further increase the fan performance and efficiency but also reduces the operational noise. Furthermore, the structural strength of the air guiding cover is also increased, such that the air guiding cover is less likely to deform during formation or operation, increasing the yield.

## Claims

### 1. An impeller comprising:

- a hub (1);
- an extension disc (2) connected to the hub (1);
- a plurality of blades (3) disposed annularly around the hub (1), wherein each of the plurality of blades (3) has a bottom edge (3a) connected to the extension disc (2); and
- an air guiding cover (4) connected to top edges (3b) of the plurality of blades (3), wherein the air guiding cover (4) includes an air inlet edge (4a) which encircles and delimits an air inlet (T1), wherein the air guiding cover (4) further includes an air outlet edge (4b), wherein a plurality of air outlets (T2) is formed between the air outlet edge (4b) of the air guiding cover (4) and an outer edge (2b) of the extension disc (2) and is separated from each other by the plurality of blades (3), wherein the air guiding cover (4) further includes an inner face (41) having a plurality of grooves (43), wherein each two adjacent blades (3) have at least one of the plurality of grooves (43) therebetween, wherein each groove (43) extends from a respective air outlet (T2) towards the air inlet (T1), and wherein a width (W1) of each groove (43) decreases from the respective air outlet (T2) towards the air inlet (T1);
- wherein each groove (43) includes an inner end (431) and an outer end (432), wherein the inner end (431) of each groove (43) is located be-

- tween the air inlet edge (4a) and the air outlet edge (4b) of the air guiding cover (4), wherein the outer end (432) of each groove (43) is located on the air outlet edge (4b) of the air guiding cover (4);
- characterized in that** each groove (43) includes two sides (433) connected to the inner end (431) and the outer end (432), and wherein each of the two sides (433) extends rectilinearly from the inner end (431) to the outer end (432).
2. The impeller as claimed in claim 1, **characterized in that** the air inlet edge (4a) and the air outlet edge (4b) of the air guiding cover (4) have a radial spacing (D1) therebetween, wherein each air outlet (T2) includes a front side (E1) and a rear side (E2) behind the front side (E1) with respect to a rotating direction, wherein one of the two sides (433) of each groove (43) adjacent to the front side (E1) of the respective air outlet (T2) has a rectilinear distance (D2) between the inner end (431) and the outer end (432), and wherein the rectilinear distance (D2) is 0.8-2 times the radial spacing (D1).
  3. The impeller as claimed in claim 1, **characterized in that** a width (W2) of each air outlet (T2) is 2-8 times the width (W1) of each groove (43) at the respective air outlet (T2).
  4. The impeller as claimed in claim 1, **characterized in that** each air outlet (T2) includes a front side (E1) and a rear side (E2) behind the front side (E1) with respect to a rotating direction, and wherein a width (W3) from the front side (E1) to one of the two sides (433) of each groove (43) nearest to the front side (E1) is 1-3 times the width (W1) of each groove (43) at the respective air outlet (T2).
  5. The impeller as claimed in claim 1, **characterized in that** each air outlet (T2) includes a front side (E1) and a rear side (E2) behind the front side (E1) with respect to a rotating direction, and wherein a height (H) in at least a portion of each air outlet (T2) decreases from the front side (E1) towards the rear side (E2) of the air outlet (T2).
  6. The impeller as claimed in claim 5, **characterized in that** the inner face (41) of the air guiding cover (4) includes a plurality of arcuate guiding portions (45) respectively corresponding to the plurality of air outlets (T2), wherein each arcuate guiding portion (45) is contiguous to the rear side (E2) of the respective air outlet (T2) and has a peak (451), and wherein the height (H) in a portion of each air outlet (T2) without the groove (43) increases from the peak (451) towards the front side (E1) of the air outlet (T2) and increases from the peak (451) towards the rear side (E2) of the air outlet (T2).
  7. The impeller as claimed in claim 6, **characterized in that** the air guiding cover (4) includes an outer face (42) having a plurality of recessed portions (44) aligned with the plurality of arcuate guiding portions (45), respectively.
  8. The impeller as claimed in claim 1, **characterized in that** each two adjacent blades (3) have at least two grooves (43) therebetween.
  9. The impeller as claimed in claim 8, **characterized in that** the grooves (43) in the same air outlet (T2) have the same width (W1) at the air outlet (T2).
  10. The impeller as claimed in claim 1, **characterized in that** the inner face (41) of the air guiding cover (4) includes at least one protruding portion (P) contiguous to one of the two sides (433) of a respective groove (43), and wherein an outer face (42) of the air guiding cover (4) includes at least one recessed portion (44) aligned with the at least one protruding portion (P).
  11. The impeller as claimed in claim 1, **characterized in that** the air guiding cover (4) includes a flange (46) connected to the air outlet edge (4b) of the air guiding cover (4).
  12. A centrifugal fan **characterized in** comprising:
    - a base (7) including a shaft coupling portion (71);
    - a stator (8) disposed around the shaft coupling portion (71); and
    - an impeller (F) set forth in any one of claims 1-11, wherein the hub (1) is coupled to a shaft (5) rotatably mounted to the shaft coupling portion (71), and wherein a magnetic member (6) is disposed peripherally around the shaft (5) and is aligned with the stator (8).

#### Patentansprüche

##### 1. Laufrad, umfassend:

eine Nabe (1);  
 eine Verlängerungsscheibe (2), die mit der Nabe (1) verbunden ist;  
 mehrere Blätter (3), die ringförmig um die Nabe (1) angeordnet sind, wobei jedes der mehreren Blätter (3) eine Unterkante (3a) aufweist, die mit der Verlängerungsscheibe (2) verbunden ist; und  
 eine Luftführungsabdeckung (4), die mit Oberkanten (3b) der Vielzahl von Blättern (3) verbunden ist, wobei die Luftführungsabdeckung (4) ei-

- ne Lufteinlasskante (4a) umfasst, die einen Lufteinlass (T1) umgibt und begrenzt, wobei die Luftführungsabdeckung (4) ferner eine Luftauslasskante (T1) umfasst, wobei mehrere Luftauslässe (T2) zwischen der Luftauslasskante (4b) der Luftführungsabdeckung (4) und einer Außenkante (2b) der Verlängerungsscheibe (2) ausgebildet sind und durch die mehreren Blätter (3) voneinander getrennt sind, wobei die Luftführungsabdeckung (4) ferner eine Innenfläche (41) mit mehreren Nuten (43) umfasst, wobei jeweils zwei benachbarte Blätter (3) mindestens eine der mehreren Nuten (43) dazwischen aufweisen, wobei sich jede Nut (43) von einem jeweiligen Luftauslass (T2) in Richtung des Lufteinlasses (T1) erstreckt und wobei eine Breite (W1) jeder Nut (43) von dem jeweiligen Luftauslass (T2) in Richtung des Lufteinlasses (T1) abnimmt;
- wobei jede Nut (43) ein inneres Ende (431) und ein äußeres Ende (432) umfasst, wobei sich das innere Ende (431) jeder Nut (43) zwischen der Lufteinlasskante (4a) und der Luftauslasskante (4b) der Luftführungsabdeckung (4) befindet, wobei sich das äußere Ende (432) jeder Nut (43) an der Luftauslasskante (4b) der Luftführungsabdeckung (4) befindet;
- dadurch gekennzeichnet, dass** jede Nut (43) zwei Seiten (433) umfasst, die mit dem inneren Ende (431) und dem äußeren Ende (432) verbunden sind, und wobei sich jede der beiden Seiten (433) geradlinig von dem inneren Ende (431) zu dem äußeren Ende (432) erstreckt.
2. Laufrad nach Anspruch 1, **dadurch gekennzeichnet, dass** die Lufteinlasskante (4a) und die Luftauslasskante (4b) der Luftführungsabdeckung (4) einen radialen Abstand (D1) dazwischen aufweisen, wobei jeder Luftauslass (T2) eine Vorderseite (E1) und eine in Bezug auf eine Drehrichtung hinter der Vorderseite (E1) liegende Rückseite (E2) umfasst, wobei eine der beiden Seiten (433) jeder Nut (43), die zu der Vorderseite (E1) des jeweiligen Luftauslasses (T2) benachbart ist, eine geradlinige Distanz (D2) zwischen dem inneren Ende (431) und dem äußeren Ende (432) aufweist und wobei die geradlinige Distanz (D2) das 0,8-2-fache des radialen Abstands (D1) beträgt.
  3. Laufrad nach Anspruch 1, **dadurch gekennzeichnet, dass** eine Breite (W2) jedes Luftauslasses (T2) das 2-8-fache der Breite (W1) jeder Nut (43) an dem jeweiligen Luftauslass (T2) beträgt.
  4. Laufrad nach Anspruch 1, **dadurch gekennzeichnet, dass** jeder Luftauslass (T2) eine Vorderseite (E1) und eine Rückseite (E2) hinter der Vorderseite (E1) in Bezug auf eine Drehrichtung umfasst und wobei eine Breite (W3) von der Vorderseite (E1) zu einer der beiden Seiten (433) jeder Nut (43), die der Vorderseite (E1) am nächsten ist, das 1-3-fache der Breite (W1) jeder Nut (43) an dem jeweiligen Luftauslass (T2) beträgt.
  5. Laufrad nach Anspruch 1, **dadurch gekennzeichnet, dass** jeder Luftauslass (T2) eine Vorderseite (E1) und eine Rückseite (E2) hinter der Vorderseite (E1) in Bezug auf eine Drehrichtung umfasst und wobei eine Höhe (H) in zumindest einem Abschnitt jedes Luftauslasses (T2) von der Vorderseite (E1) in Richtung der Rückseite (E2) des Luftauslasses (T2) abnimmt.
  6. Laufrad nach Anspruch 5, **dadurch gekennzeichnet, dass** die Innenfläche (41) der Luftführungsabdeckung (4) mehrere bogenförmige Führungsabschnitte (45) umfasst, die jeweils den mehreren Luftauslässen (T2) entsprechen, wobei jeder bogenförmige Führungsabschnitt (45) an die Rückseite (E2) des jeweiligen Luftauslasses (T2) angrenzt und eine Spitze (451) aufweist und wobei die Höhe (H) in einem Abschnitt jedes Luftauslasses (T2) ohne die Nut (43) von der Spitze (451) in Richtung der Vorderseite (E1) des Luftauslasses (T2) zunimmt und von der Spitze (451) in Richtung der Rückseite (E2) des Luftauslasses (T2) zunimmt.
  7. Laufrad nach Anspruch 6, **dadurch gekennzeichnet, dass** die Luftführungsabdeckung (4) eine Außenfläche (42) mit mehreren vertieften Abschnitten (44) aufweist, die jeweils mit den mehreren bogenförmigen Führungsabschnitten (45) ausgerichtet sind.
  8. Laufrad nach Anspruch 1, **dadurch gekennzeichnet, dass** jeweils zwei benachbarte Blätter (3) mindestens zwei Nuten (43) dazwischen aufweisen.
  9. Laufrad nach Anspruch 8, **dadurch gekennzeichnet, dass** die Nuten (43) in demselben Luftauslass (T2) dieselbe Breite (W1) an dem Luftauslass (T2) aufweisen.
  10. Laufrad nach Anspruch 1, **dadurch gekennzeichnet, dass** die Innenfläche (41) der Luftführungsabdeckung (4) mindestens einen vorspringenden Abschnitt (P) umfasst, der an eine der beiden Seiten (433) einer jeweiligen Nut (43) angrenzt, und wobei eine Außenfläche (42) der Luftführungsabdeckung (4) mindestens einen vertieften Abschnitt (44) umfasst, der mit dem mindestens einen vorspringenden Abschnitt (P) ausgerichtet ist.
  11. Laufrad nach Anspruch 1, **dadurch gekennzeichnet, dass** die Luftführungsabdeckung (4) einen

Flansch (46) umfasst, der mit der Luftauslasskante (4b) der Luftführungsabdeckung (4) verbunden ist.

**12. Zentrifugalgebläse, dadurch gekennzeichnet, dass** es umfasst:

eine Basis (7) mit einem Wellenkopplungsabschnitt (71);  
einen Stator (8), der um den Wellenkopplungsabschnitt (71) angeordnet ist; und  
ein Laufrad (F) nach einem der Ansprüche 1-11, wobei die Nabe (1) mit einer Welle (5) gekoppelt ist, die an dem Wellenkopplungsabschnitt (71) drehbar gelagert ist, und wobei ein magnetisches Element (6) in Umfangsrichtung um die Welle (5) angeordnet ist und mit dem Stator (8) ausgerichtet ist.

**Revendications**

**1. Une roue à aubes comprenant :**

un moyeu (1) ;  
un disque d'extension (2) raccordé au moyeu (1) ;  
une pluralité de pales (3) disposées de manière annulaire autour du moyeu (1), dans laquelle chacune de la pluralité de pales (3) a un bord inférieur (3a) raccordé au disque d'extension (2) ; et  
un couvercle de guidage d'air (4) raccordé aux bords supérieurs (3b) de la pluralité de pales (3), dans laquelle le couvercle de guidage d'air (4) comprend un bord d'entrée d'air (4a) qui encercle et délimite une entrée d'air (T1), dans laquelle le couvercle de guidage d'air (4) comprend en outre un bord de sortie d'air (4b), dans laquelle une pluralité de sorties d'air (T2) sont formées entre le bord de sortie d'air (4b) du couvercle de guidage d'air (4) et un bord externe (2b) du disque d'extension (2) et sont séparées les unes des autres par la pluralité de pales (3), dans laquelle le couvercle de guidage d'air (4) comprend en outre une face interne (41) ayant une pluralité de rainures (43), dans laquelle toutes les deux pales (3) adjacentes ont au moins l'une de la pluralité de rainures (43) entre elles, dans laquelle chaque rainure (43) s'étend à partir d'une sortie d'air (T2) respective vers l'entrée d'air (T1), et dans laquelle une largeur (W1) de chaque rainure (43) diminue de la sortie d'air (T2) respective vers l'entrée d'air (T1) ;  
dans laquelle chaque rainure (43) comprend une extrémité interne (431) et une extrémité externe (432), dans laquelle l'extrémité interne (431) de chaque rainure (43) est positionnée entre le bord d'entrée d'air (4a) et le bord de sortie

d'air (4b) du couvercle de guidage d'air (4), dans laquelle l'extrémité externe (432) de chaque rainure (43) est positionnée sur le bord de sortie d'air (4b) du couvercle de guidage d'air (4) ;

**caractérisé en ce que :**

chaque rainure (43) comprend deux côtés (433) raccordés à l'extrémité interne (431) et à l'extrémité externe (432), et dans laquelle chacun des deux côtés (433) s'étend de manière rectiligne de l'extrémité interne (431) à l'extrémité externe (432).

**2. La roue à aubes selon la revendication 1, caractérisée en ce que** le bord d'entrée d'air (4a) et le bord de sortie d'air (4b) du couvercle de guidage d'air (4) ont un espacement radial (D1) entre eux, dans laquelle chaque sortie d'air (T2) comprend un côté avant (E1) et un côté arrière (E2) derrière le côté avant (E1) par rapport à une direction de rotation, dans laquelle l'un des deux côtés (433) de chaque rainure (43) adjacent au côté avant (E1) de la sortie d'air (T2) respective a une distance rectiligne (D2) entre l'extrémité interne (431) et l'extrémité externe (432), et dans laquelle la distance rectiligne (D2) représente de 0,8 à 2 fois l'espacement radial (D1).

**3. La roue à aubes selon la revendication 1, caractérisée en ce qu'**une largeur (W2) de chaque sortie d'air (T2) représente de 2 à 8 fois la largeur (W1) de chaque rainure (43) à la sortie d'air (T2) respective.

**4. La roue à aubes selon la revendication 1, caractérisée en ce que** chaque sortie d'air (T2) comprend un côté avant (E1) et un côté arrière (E2) derrière le côté avant (E1) par rapport à une direction de rotation, et dans laquelle une largeur (W3) du côté avant (E1) à l'un des deux côtés (433) de chaque rainure (43) le plus proche du côté avant (E1) représente de 1 à 3 fois la largeur (W1) de chaque rainure (43) à la sortie d'air (T2) respective.

**5. La roue à aubes selon la revendication 1, caractérisée en ce que** chaque sortie d'air (T2) comprend un côté avant (E1) et un côté arrière (E2) derrière le côté avant (E1) par rapport à une direction de rotation, et dans laquelle une hauteur (H) dans au moins une partie de chaque sortie d'air (T2) diminue du côté avant (E1) vers le côté arrière (E2) de la sortie d'air (T2).

**6. La roue à aubes selon la revendication 5, caractérisée en ce que** la face interne (41) du couvercle de guidage d'air (4) comprend une pluralité de parties de guidage arquées (45) correspondant respectivement à la pluralité de sorties d'air (T2), dans laquelle chaque partie de guidage arquée (45) est contiguë au côté arrière (E2) de la sortie d'air (T2) respective et a un pic (451), et dans laquelle la hauteur (H) dans

une partie de chaque sortie d'air (T2) sans la rainure (43) augmente du pic (451) vers le côté avant (E1) de la sortie d'air (T2) et augmente du pic (451) vers le côté arrière (E2) de la sortie d'air (T2).

5

7. La roue à aubes selon la revendication 6, **caractérisée en ce que** le couvercle de guidage d'air (4) comprend une face externe (42) ayant une pluralité de parties enfoncées (44) alignée avec la pluralité de parties de guidage arquées (45), respectivement. 10
8. La roue à aubes selon la revendication 1, **caractérisée en ce que** toutes les deux pales (3) adjacentes ont au moins deux rainures (43) entre elles. 15
9. La roue à aubes selon la revendication 8, **caractérisée en ce que** les rainures (43) dans la même sortie d'air (T2) ont la même largeur (W1) à la sortie d'air (T2). 20
10. La roue à aubes selon la revendication 1, **caractérisée en ce que** la face interne (41) du couvercle de guidage d'air (4) comprend au moins une partie en saillie (P) contiguë à l'un des deux côtés (433) d'une rainure (43) respective, et dans laquelle une face externe (42) du couvercle de guidage d'air (4) comprend au moins une partie enfoncée (44) alignée avec la au moins une partie en saillie (P). 25
11. La roue à aubes selon la revendication 1, **caractérisée en ce que** le couvercle de guidage d'air (4) comprend une bride (46) raccordée au bord de sortie d'air (4b) du couvercle de guidage d'air (4). 30
12. Un ventilateur centrifuge **caractérisé en ce qu'il** comprend : 35

une base (7) comprenant une partie de couplage d'arbre (71) ;

un stator (8) disposé autour de la partie de couplage d'arbre (71) ; et 40

une roue à aubes (F) selon l'une quelconque des revendications 1 à 11, dans laquelle le moyeu (1) est couplé à un arbre (5) monté, de manière rotative, sur la partie de couplage d'arbre (71), et dans laquelle un élément magnétique (6) est disposé de manière périphérique autour de l'arbre (5) et est aligné avec le stator (8). 45

50

55

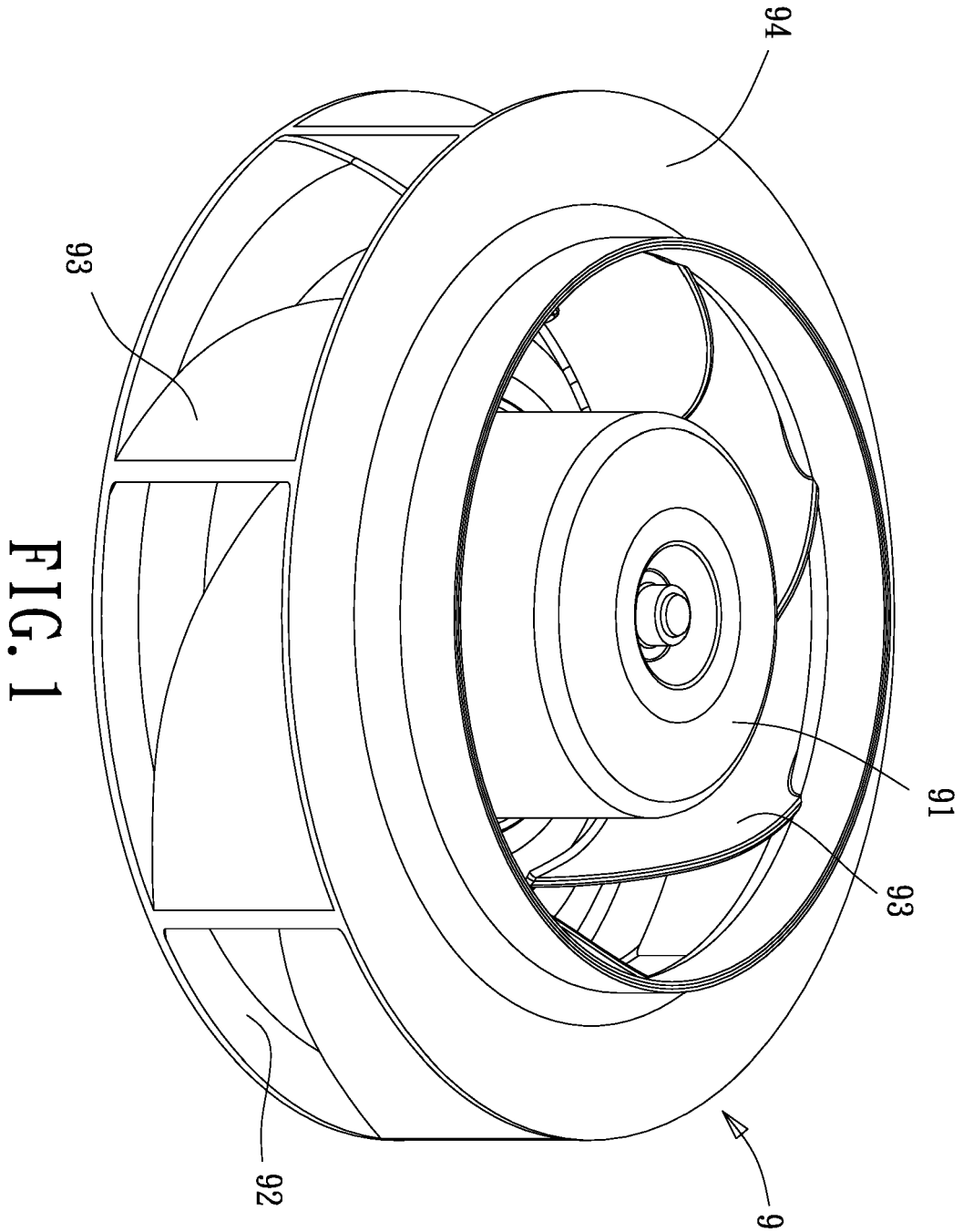

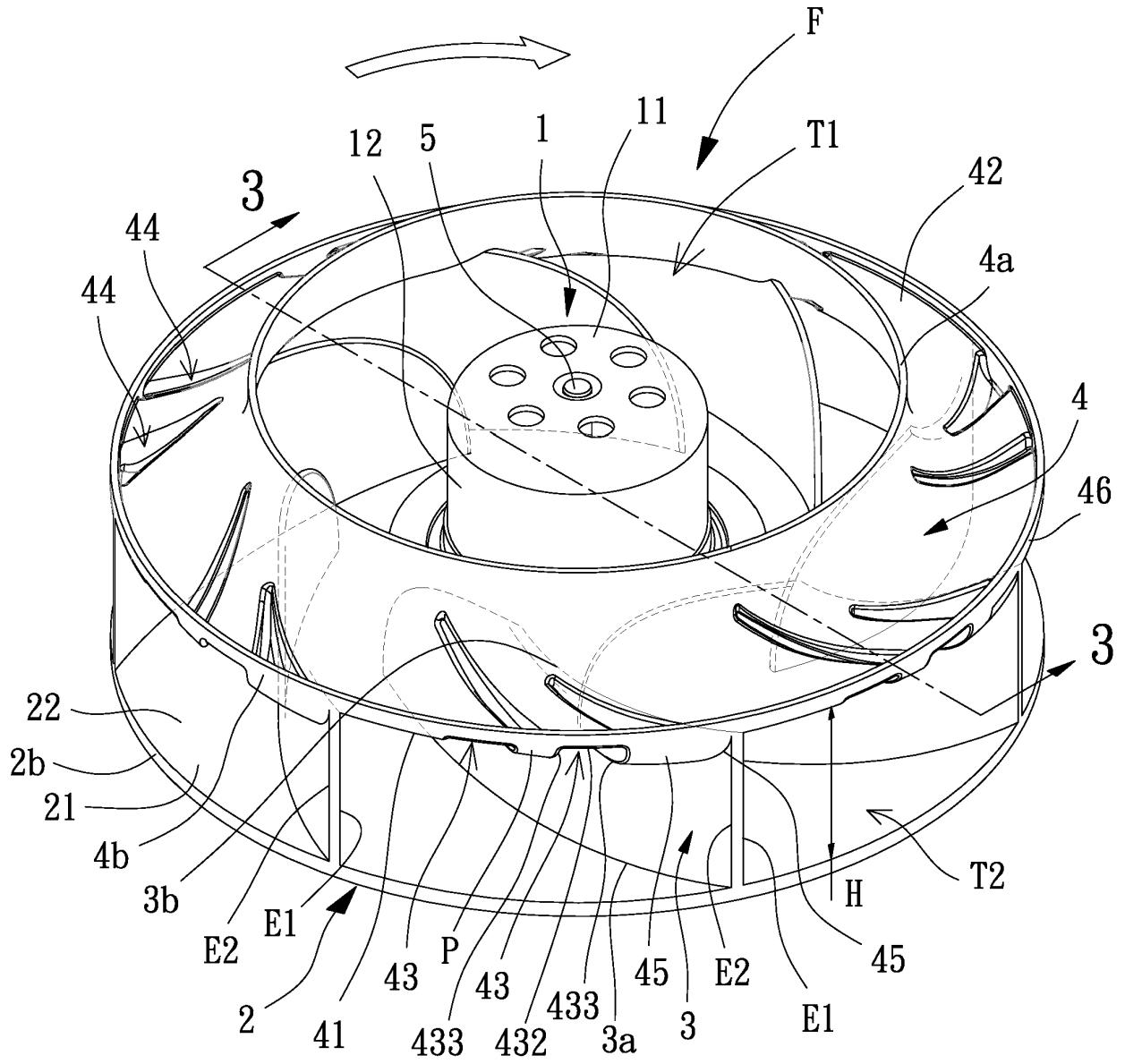

FIG. 2

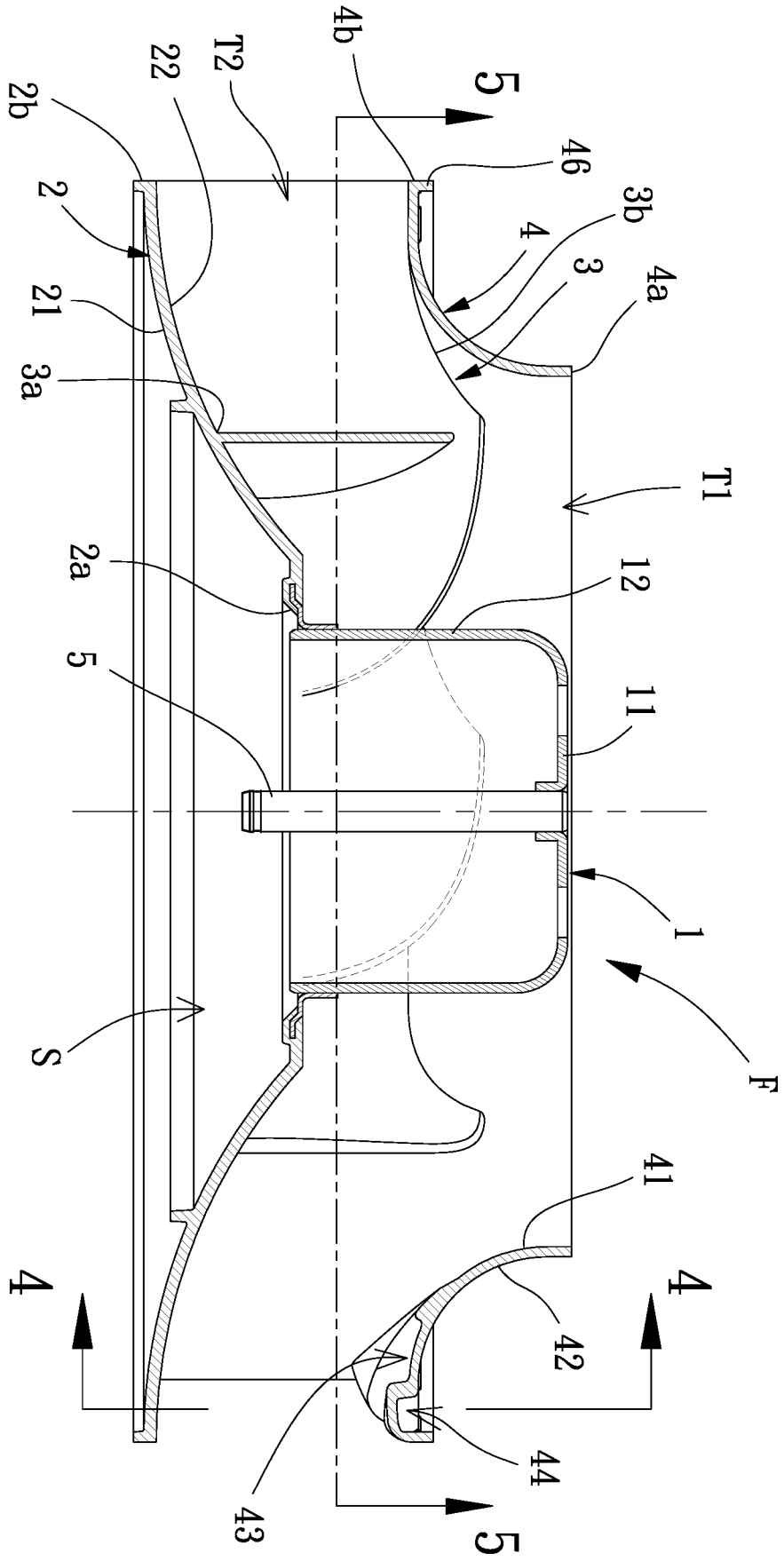

FIG. 3



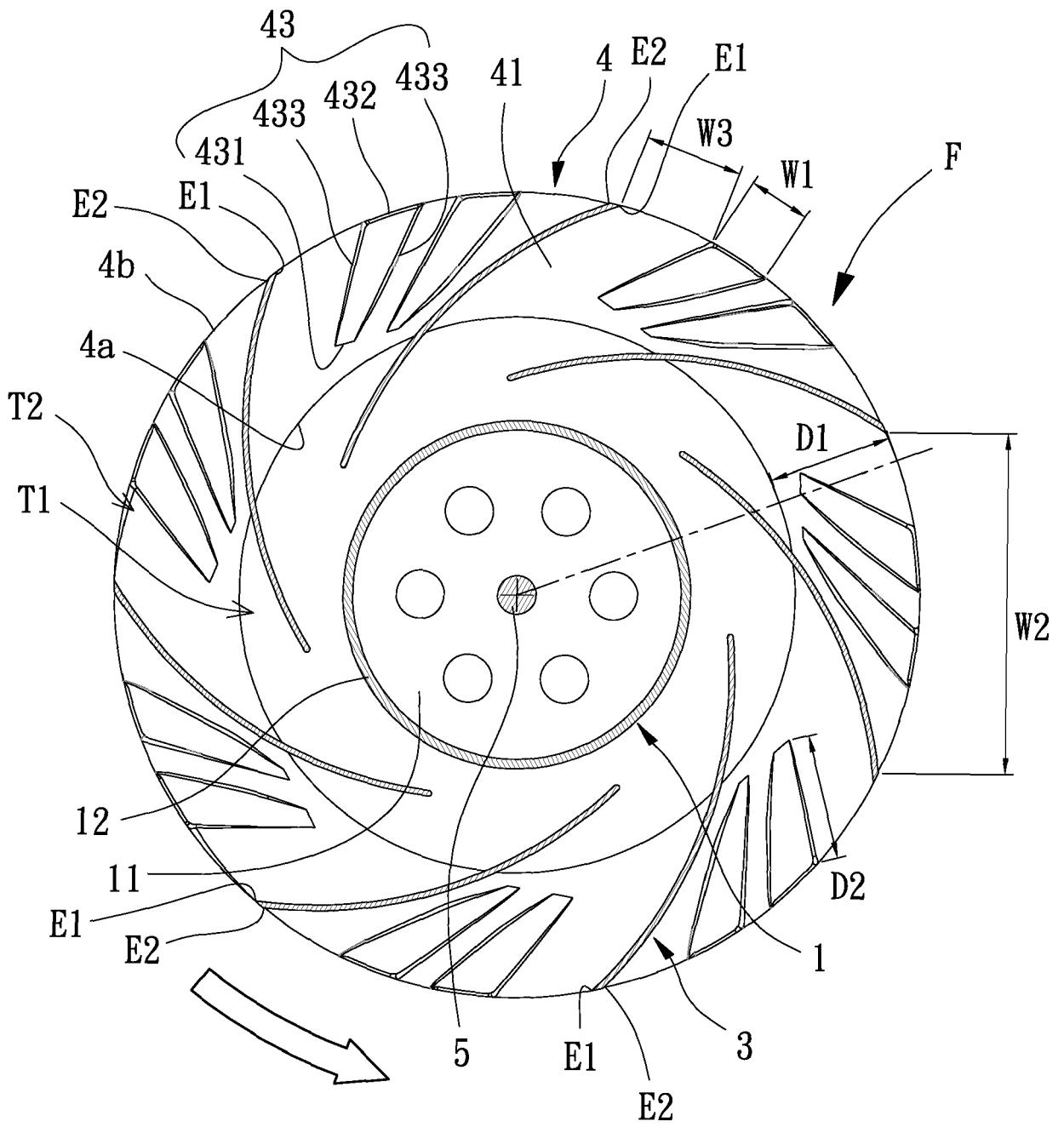

FIG. 5

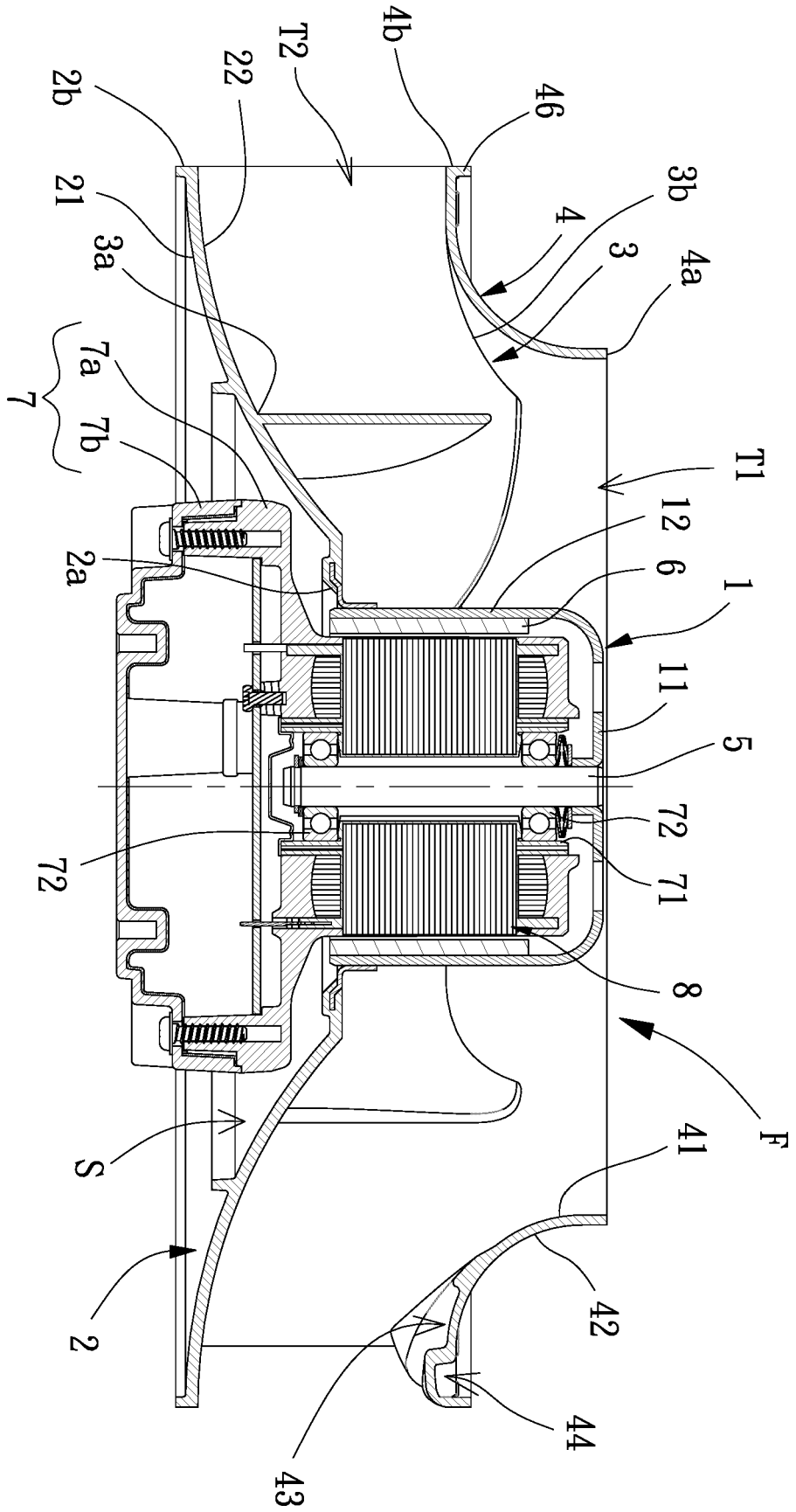

FIG. 6

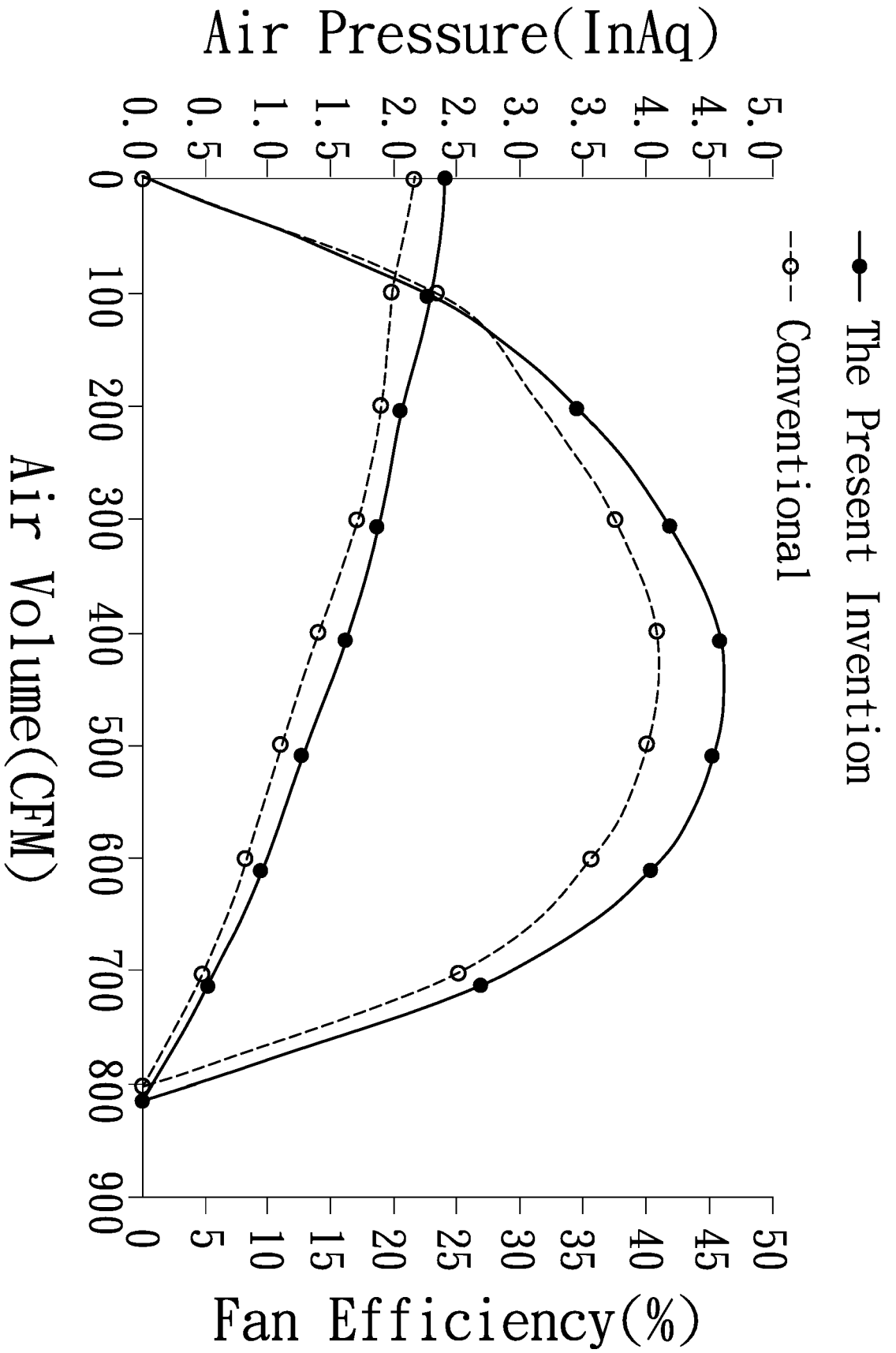

FIG. 7

**REFERENCES CITED IN THE DESCRIPTION**

*This list of references cited by the applicant is for the reader's convenience only. It does not form part of the European patent document. Even though great care has been taken in compiling the references, errors or omissions cannot be excluded and the EPO disclaims all liability in this regard.*

**Patent documents cited in the description**

- TW 1653397 [0002]
- EP 3101280 A1 [0002]
- US 2015369073 A1 [0004]