



(11) **EP 3 950 519 A1**

(12) **EUROPEAN PATENT APPLICATION**
published in accordance with Art. 153(4) EPC

(43) Date of publication:
09.02.2022 Bulletin 2022/06

(51) International Patent Classification (IPC):
B65D 1/02 ^(2006.01) **B65D 1/42** ^(2006.01)

(21) Application number: **20783822.8**

(52) Cooperative Patent Classification (CPC):
B65D 1/02; B65D 1/42

(22) Date of filing: **23.01.2020**

(86) International application number:
PCT/JP2020/002376

(87) International publication number:
WO 2020/202727 (08.10.2020 Gazette 2020/41)

(84) Designated Contracting States:
AL AT BE BG CH CY CZ DE DK EE ES FI FR GB GR HR HU IE IS IT LI LT LU LV MC MK MT NL NO PL PT RO RS SE SI SK SM TR
Designated Extension States:
BA ME
Designated Validation States:
KH MA MD TN

(72) Inventors:
• **KIRA Go**
Tokyo 135-8631 (JP)
• **TAKEDA Tomomi**
Tokyo 135-8631 (JP)
• **YOKOI Hisashi**
Tokyo 135-8631 (JP)

(30) Priority: **29.03.2019 JP 2019067730**

(74) Representative: **Vossius & Partner**
Patentanwälte Rechtsanwälte mbB
Siebertstraße 3
81675 München (DE)

(71) Applicant: **Suntory Holdings Limited**
Osaka 530-8203 (JP)

(54) **PLASTIC BOTTLE**

(57) Provided is a plastic bottle that can effectively resist occurrence of the buckling phenomenon at the time of freeze-storage of non sugared drink while achieving yet desirable weight and thickness reduction of the plastic bottle.

bottom portion 6 and a plurality of ground-contacting portions 64. A maximum circumferential length of the ground-contacting portion 64 is set greater than a maximum circumferential length of the valley portion 62 and the deepest part of the valley portion 62 forms an outwardly convex arc 63 extending continuously upwards from the bottom face 60 to the side face 61.

A plastic bottle 1 having a cylindrical bottom portion 6 includes a plurality of valley portions 62 protruding inwards from a side face 61 to a bottom face 60 of the

Fig.3

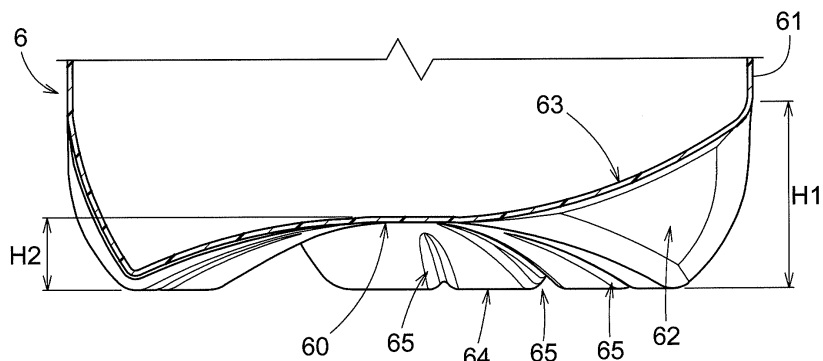

EP 3 950 519 A1

Description**Field of the Invention**

[0001] The present invention relates to a plastic bottle having a cylindrical bottom portion.

Description of Related Art

[0002] In freeze-storing a plastic bottle containing beverage, in association with expansion of the beverage involving phase change thereof from liquid to solid, there sometimes occurs a buckling phenomenon involving outward protrusive deformation of the bottom portion of the plastic bottle.

[0003] For preventing such buckling phenomenon, at the bottom portion of the conventional plastic bottle for freeze storage of beverage, there is provided a structure similar to a petaloid shape. This structure referred to as petaloid profile is employed in pressure-resistant PET bottles for carbonated drinks and resists the internal pressure due to carbon dioxide gas, thereby to prevent deformation of the PET bottle.

SUMMARY**PROBLEM TO BE SOLVED BY INVENTION**

[0004] The thermal expansion coefficient of beverage due to freeze-storage is higher with non-sugared (no sugar-added) drink than with sugared (sugar-added) drink. With the conventional plastic bottle, while suppression of the buckling phenomenon may be possible with the sugared drink, the suppression is difficult to achieve with non-sugared drink. An obvious conceivable solution for the suppression of the buckling phenomenon would be increase of the amount of resin used in the plastic bottle for desired increase of strength of the entire plastic bottle. However, in accordance with ever increasing need for resource and cost saving, there is a need for reduction in the weight and thickness of the plastic bottle.

[0005] In view of the above, it is desired to realize a plastic bottle that can effectively resist occurrence of the buckling phenomenon at the time of freeze-storage of non sugared drink while achieving yet desirable weight and thickness reduction of the plastic bottle.

SOLUTION

[0006] A plastic bottle according to the present invention, provided as a plastic bottle having a cylindrical bottom portion, comprises:

a plurality of valley portions protruding inwards from a side face to a bottom face of the bottom portion; and a plurality of ground-contacting portions; wherein a maximum circumferential length of the ground-contacting portion is set greater than a maximum circumferential length of the valley portion; and wherein the deepest part of the valley portion forms an outwardly convex arc extending continuously upwards from the bottom face to the side face.

imum circumferential length of the valley portion; and wherein the deepest part of the valley portion forms an outwardly convex arc extending continuously upwards from the bottom face to the side face.

[0007] With the above-described configuration, by providing the deepest parts of the plurality of valley portions provided in the bottom portion in the arc form, it is possible to promote uniform dispersion of expansion pressure from the beverage at the time of its freeze-storage such that the pressure at the time of expansion were supported, as if, by a partial spherical face including the deepest parts of the plurality of valley portions. Consequently, even in the case of freeze-storage of non sugared beverage having high expansion coefficient, the buckling phenomenon hardly occurs. Moreover, thanks to the setting of the maximum circumferential length of the ground-contacting portion which comes into contact with a mounting surface such as a desk greater than the maximum circumferential length of the valley portion, toppling of the bottle will hardly occur at the time of conveying thereof by means of a conveyer or the like.

[0008] In the present invention, preferably, three ground-contacting portions are provided with an approximately equal circumferential spacing therebetween.

[0009] With the above-described arrangement of providing three ground-contacting portions, it is possible to secure a larger ground-contacting area than the conventional petaloid arrangement having five such ground-contacting portions. As a result, the possibility of toppling of the bottle at the time of e.g. conveying thereof by a conveyer or the like can be further reduced and it becomes also possible to achieve favorable moldability or formability of the bottom portion.

[0010] In the present invention, preferably, the bottle further comprises a plurality of groove portions extending from the side face via the ground-contacting portion to the bottom face, the groove portions being provided with an approximately equal circumferential spacing therebetween in the ground-contacting portion.

[0011] With the above-described arrangement, at the time of molding, sterilization, etc. of the plastic bottle, occurrence of sink marks therein can be suppressed even when the plastic bottle is designed for its weight and thickness reduction.

[0012] In the present invention, preferably, at least one of the plurality of groove portions extends to the vicinity of the center portion of the bottom face.

[0013] With the above-described inventive arrangement, as at least one of the plurality of groove portions extends to the vicinity of the center portion of the bottom face, the possibility of occurrence of the buckling phenomenon can be reduced even more effectively.

[0014] In the present invention, preferably, the bottom face has a partial spherical shape that protrudes inwards.

[0015] With the above-described inventive arrangement, there is no shape referred to as a dome portion protruding to the inner side of the bottom which portion

would be provided at the center portion of the bottom face of the conventional plastic bottle. For this reason, no portion tending to invite stress concentration is present in the bottle, so that the stress concentration can be lessened effectively. Thus, even when the plastic bottle is dropped accidentally, the bottle can effectively withstand its impact, so that breakage of the bottom is prevented.

[0016] In the present invention, preferably, the plastic bottle is used for freezing.

[0017] With the above-described arrangement, the invention can be applied to a plastic bottle for freezing, so that even when the bottle is frozen, its deformation can be suppressed and this bottle is convenient also for carrying by a user.

BRIEF DESCRIPTION OF THE DRAWINGS

[0018]

Fig. 1 is a front view of a plastic bottle,

Fig. 2 is a bottom view showing a bottom portion of the plastic bottle,

Fig. 3 is a vertical section view of the bottom portion taken along a line III-III in Fig. 2,

Fig. 4 is a side view showing mainly a valley portion of the bottom portion of the plastic bottle,

Fig. 5 is a side view showing mainly groove portions of the bottom portion of the plastic bottle, and

Fig. 6 is a perspective view of a bottom face of the bottom portion of the plastic bottle.

EMBODIMENT

[0019] Next, an embodiment of the present invention will be explained with reference to the accompanying drawings.

[0020] As shown in Fig. 1, a plastic bottle 1 relating to this embodiment includes a neck portion 2 serving as a mouth or spout for dispensing liquid and a bottle main body portion 3 to be filled with liquid.

[0021] The bottle main body portion 3 includes a shoulder portion 4 formed continuously from the neck portion 2 and having a diameter which progressively increases in the direction toward a body portion 5, the cylindrical body portion 5 formed continuously from the shoulder portion 4 and a cylindrical bottom portion 6 forming the bottom of the plastic bottle 1.

[0022] An upper portion 50 of the body portion 5 provides a label-affixing area in which a roll label is to be affixed and includes a plurality of circumferential grooves 52 for reinforcement. In a lower portion 51 of the body portion 5, there is formed an uneven face 53 having a plurality of circumferential grooves in curved forms, with taking into consideration reinforcement, readiness of user's holding of the bottom and aesthetic respect also.

[0023] Incidentally, what is referred to as the "bottom portion 6" in this embodiment means the portion of the

plastic bottle 1 excluding the neck portion 2, the shoulder portion 4 and the body portion 5. In the instant embodiment, a portion slightly upwards from starting positions of valley portions 62 to a ground-contacting portions 64 is the bottom portion 6 and a vertical length of this bottom portion 6 (the height measured from the ground-contacting portion 64 to the borderline between the side face 61 and the body portion 5) can be set to e.g. from 20 mm to 22 mm.

[0024] As shown in Fig. 2, Fig. 4 and Fig. 5, the bottom portion 6 includes a plurality of valley portions 62 protruding inwards from the side face 61 of the bottom portion 6 to the vicinity of the center of the bottom face 60 and a plurality of ground-contacting portions 64 which come into contact with a mounting surface such as a desk. In the bottom portion 6 of this embodiment, three ground-contacting portions 64 are provided in an approximately equal spacing therebetween in the circumferential direction and between two ground-contacting portions 64 adjacent each other in the circumferential direction, one valley portion 62 is provided.

[0025] As shown in Fig. 2, in the bottom portion 6, the plurality of ground-contacting portions 64 are positioned on a same circumference of the outermost circumferential portion of the bottom face 60. A maximum circumferential length L1 of the ground-contacting portion 64 varies in accordance with a maximum circumferential length L2 of the valley portion 62. Yet, in this particular embodiment, as shown in Fig. 2, the maximum circumferential length L1 of the ground-contacting portion 64 is set longer than the maximum circumferential length L2 of the valley portion 62 ($L1 > L2$).

[0026] Incidentally, the shape of the ground-contacting portion 64 is not limited to the particular shape shown in Figs. 2 and 6 and the magnitude of its radial width may be set as desired.

[0027] As shown in Fig. 3, the deepest part of the valley portion 62 extends continuously in a form of an outwardly convex arc 63 from the vicinity of the center of the bottom face 60 upwardly to the side face 61. Incidentally, the term "upwardly" in the language of upwardly from the center of the bottom face 60 refers to the side where the neck portion 2, the shoulder portion 4 and the body portion 5 are present as seen from the bottom face 60 of the plastic bottle 1.

[0028] The deepest part of the valley portion 62 in this embodiment extends to the center portion of the bottom face 60. However, this is not limiting. If the deepest part of the valley portion 62 is closer to the center portion of the bottom face 60, the shape will approximate a spherical shape suitable for stress dispersion, so the effect of suppressing the buckling phenomenon will increase. However, it should be noted that the sole requirement for the deepest part of the valley portion 62 is its arrival at the bottom face 60, while its extension to the vicinity of the center portion of the bottom face 60 is not an absolute requirement.

[0029] As shown in Fig. 3 and Fig. 6, the bottom face

60 provided in this embodiment is a partial spherical shape protruding inwards. The deepest part of the valley portion 62 extends continuously in the form of a smooth arc 63 from the top portion of the bottom face 60 to the side face 61 of the bottom portion 6.

[0030] In the bottom face 60 provided in this embodiment, there is no shape referred to as a "dome portion" protruding to the inner side of the bottom which portion would be provided at the center portion of the bottom face of the conventional plastic bottle. For this reason, no portion tending to invite stress concentration is present in the bottle, so that the stress concentration can be lessened effectively. Thus, even when the plastic bottle 1 is dropped accidentally, the bottle can effectively withstand its impact and breakage of the bottom can be prevented.

[0031] Forming the deepest parts of the plurality of valley portions 62 provided in the bottom portion 6 in the form of arcs 63 facilitates uniform dispersion of the expansion pressure of the beverage at the time of its freezing, providing a condition in which the inner pressure is supported by a partial spherical face including the deepest parts of the plurality of valley portions 62 (see Fig. 5). Thus, even in the case of freezing of non sugared beverage having a high expansion coefficient, the buckling phenomenon would hardly occur. Moreover, since the maximum circumferential length L1 of the ground-contacting portion 64 which come into contact with a mounting surface such as a desk greater than the maximum circumferential length of the valley portion 62, toppling would hardly occur either at the time of conveyance of a conveyer or the like.

[0032] As shown in Fig. 3, a height H1 of the valley portion 62 can be set within a range from 12 mm to 25 mm for example. If this height H1 of the valley portion 62 is too large, this will lead to deterioration in the moldability and also greater possibility of toppling due to the corresponding decrease in the area of the ground-contacting portion 64, conversely, if the height H1 is too small, the buckling phenomenon would occur more likely. Thus, the height should be set with consideration to these respects. The height H1 of the valley portion 62 which can achieve more favorable results in all of the respects of the moldability, the toppling resistance, the buckling phenomenon resistance ranges from 15 mm to 22 mm, especially preferable from 15 mm to 18 mm.

[0033] Incidentally, advantageously, the curvature radius of the arc 63 of the deepest part of the valley portion 62 should be such an amount that can ensure favorable effect against the internal pressure and favorable bottle moldability. Specifically, the curvature radius range advantageously from about 40 mm (R40) to about 60 mm (R60).

[0034] Further, by providing three ground-contacting portions 64, it becomes possible to increase the ground-contacting area than the case of the conventional petaloid profile having five ground-contacting portions 64. As a result, the possibility of toppling at the time of convey-

ance by a conveyer or the like can be even lessened and favorable moldability of the bottom portion 6 can be ensured more easily. However, the number of the ground-contacting portions 64 is not limited to the above, but may be changed as desired with consideration to such factors as the moldability, the toppling resistance, the buckling phenomenon resistance, etc.

[0035] As shown in Fig. 2, Figs. 4-6, three groove portions 65 extending from the side face 61 of the bottom portion 6 via the ground-contacting portion 64 to the bottom face 60 are provided with an approximately equal spacing therebetween in the circumferential direction in the ground-contacting portion 64. With the above-described arrangement, at the time of molding, sterilization, etc. of the plastic bottle 1, formation of sink marks can be suppressed even when the plastic bottle 1 is designed positively for its weight and thickness reduction. The number of such groove portions 65 is not limited to the above, but may be changed as desired with consideration to such factors as the moldability, the sink mark formation suppressing effect, etc. However, in the case of this particular embodiment, when two groove portions 65 are provided, the possibility of formation of the sink marks will be higher; and when four groove portions 65 are provided, it will become difficult to obtain favorable moldability.

[0036] As shown in Fig. 2 and Fig. 6, in this embodiment, in each one ground-contacting portion 64, three groove portions 65 are provided with the approximately equal spacing in the circumferential direction and only the groove portion 65 located at the center among them extends to the vicinity of the center of the bottom face 60. As the grooves portion 65 extends to the vicinity of the center of the bottom face 60, this arrangement can further reduce the possibility of the buckling phenomenon. Although it is possible to extend all of the plurality of groove portions 65 to the vicinity of the center portion; however, if such factors as the moldability, etc. are considered, it is advantageous that at least one of the plurality of groove portions 65 extends to the vicinity of the center portion. And, taking such factors as described above, the number of the groove portions 65 to be extended to the vicinity of the center of the bottom face 60 may be changed suitably.

[0037] In this embodiment, the circumferential length of the groove portion 65 is set shorter than the maximum circumferential length of the valley portion 62.

[0038] As shown in Fig. 3, advantageously, a bottom-up height H2 (height from the ground-contacting portion 64 to the center portion of the bottom face 60) ranges from 2 mm to 10 mm, especially advantageously from 4 mm to 7 mm, from the viewpoints of effective suppression of the buckling phenomenon, the favorable moldability of the bottle and readiness to prevent bottle breakage at time of dropping.

[0039] The liquid to be filled in the plastic bottle 1 of this embodiment is not particularly limited. The liquid can be e.g. any drink such as drinking water, tea, juice, coffee,

chocolate drink, soft drink, alcoholic drink, milk beverage, soup, or any liquid seasoning such as Worcestershire sauce, soy sauce, etc. Further, in the case of beverage or drink in particular, it may be sugared drink or non-sugared drink. In the case of freezing of non-sugared drink, the plastic bottle 1 of this embodiment can be suitably used.

[0040] The plastic bottle 1 of this embodiment can be used for any use such as normal temperature use, refrigerating use, freezing use, but it may be used for freezing particularly suitably.

[0041] The plastic bottle 1 of this embodiment can be integrally molded by a stretch molding technique such as the biaxial stretch blow molding technique, with using, as a principal material thereof, a thermoplastic resin such as polyethylene, polypropylene, polyethylene terephthalate, etc. The capacity of the plastic bottle 1 is not particularly limited, but can be approximately from 200 milliliters to 2 liters which are commonly used, especially preferably from 250 milliliters to 1 liter.

[0042] The plastic bottle 1 of this embodiment can be formed thinner than the standard plastic bottle for beverage, for the sake saving of material and cost. Specifically, preferably, the ratio of the amount of resin (g) used the plastic bottle 1 relative to the full order capacity (ml) of the plastic bottle 1 ranges from 0.017 to 0.041 (g/ml), more preferably, from 0.023 to 0.037. If the ratio of the resin amount relative to the full order capacity exceeds 0.041 (g/ml), such bottle can no longer be classified as a thin and light-weight bottle. Conversely, if the ratio of the resin amount relative to the full order capacity falls below 0.017 (g/ml), the thickness will be too small to ensure sufficient strength.

[0043] It should be understood that the foregoing embodiments disclosed herein are illustrative in all respects and the scope of the present invention is not limited thereto. One skilled in the art would readily understand that various modifications are possible within a range not deviating from the essence of the present invention.

INDUSTRIAL APPLICABILITY

[0044] The present invention is suitably applicable to a plastic bottle for freezing.

DESCRIPTION OF SIGNS

[0045]

1: plastic bottle
 2: neck portion (mouth or spout)
 3: bottle main body portion
 4: shoulder portion
 5: body portion
 50: upper portion
 51: lower portion
 52: circumferential groove
 53: uneven face

6: bottom portion
 60: bottom face
 61: side face
 62: valley portion
 5 63: arc
 64: ground-contacting portion
 65: groove portion
 L1: maximum circumferential length of ground-contacting portion
 10 L2: maximum circumferential length of valley portion
 H1: height of valley portion
 H2: bottom-up height

15 Claims

1. A plastic bottle having a cylindrical bottom portion, comprising:

20 a plurality of valley portions protruding inwards from a side face to a bottom face of the bottom portion; and
 a plurality of ground-contacting portions;
 25 wherein a maximum circumferential length of the ground-contacting portion is set greater than a maximum circumferential length of the valley portion; and
 30 wherein the deepest part of the valley portion forms an outwardly convex arc extending continuously upwards from the bottom face to the side face.

2. The plastic bottle of claim 1, wherein three ground-contacting portions are provided with an approximately equal circumferential spacing therebetween.

3. The plastic bottle of claim 1 or 2, further comprising a plurality of groove portions extending from the side face via the ground-contacting portion to the bottom face, the groove portions being provided with an approximately equal circumferential spacing therebetween in the ground-contacting portion.

4. The plastic bottle of claim 3, wherein at least one of the plurality of groove portions extends to the vicinity of the center portion of the bottom face.

5. The plastic bottle of any one of claims 1-4, wherein the bottom face has a partial spherical shape that protrudes inwards.

6. The plastic bottle of any one of claims 1-5, wherein the plastic bottle is used for freezing.

Fig.1

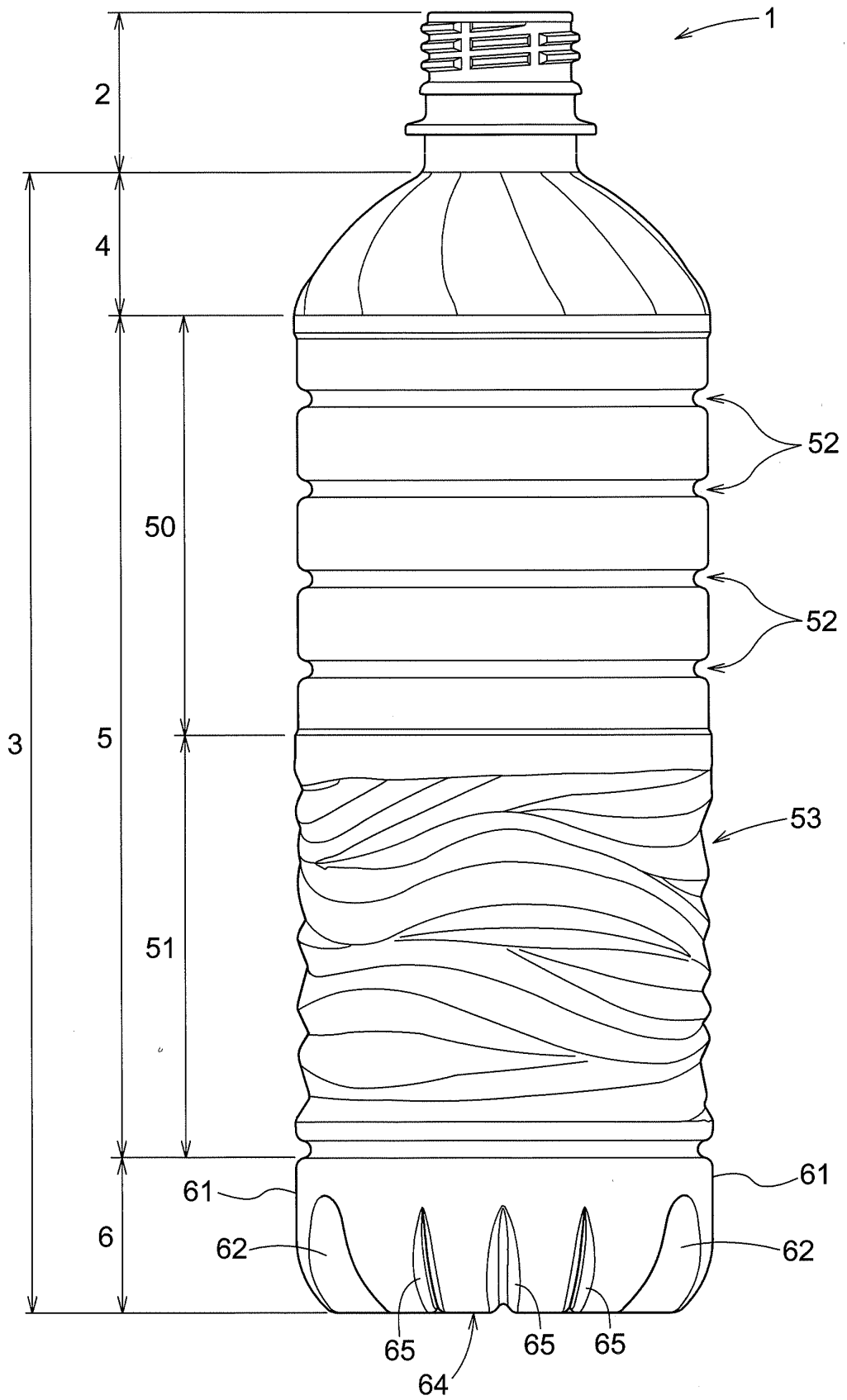

Fig.4

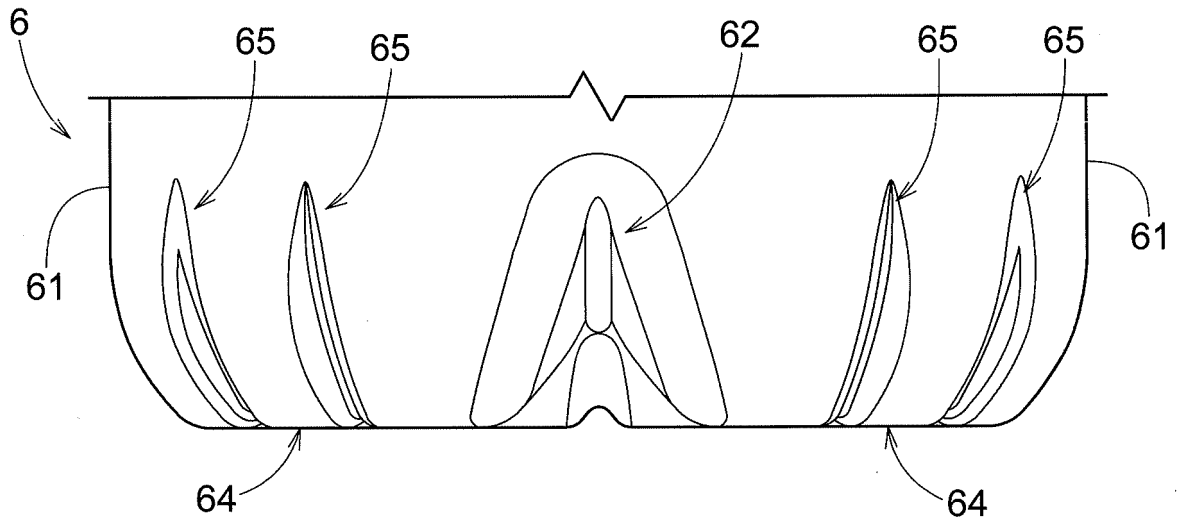

Fig.5

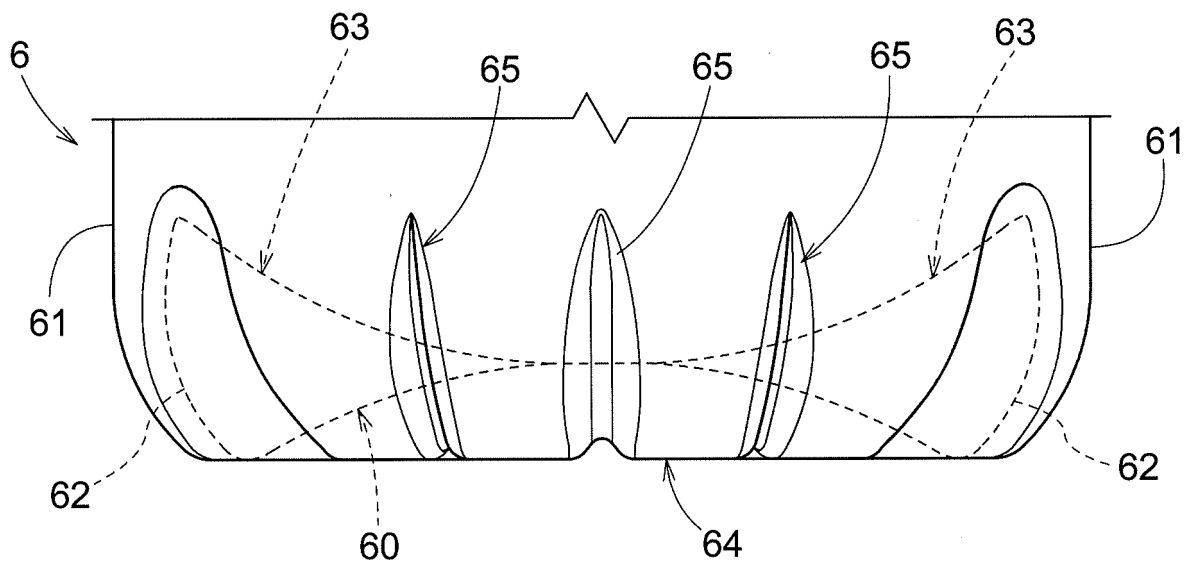
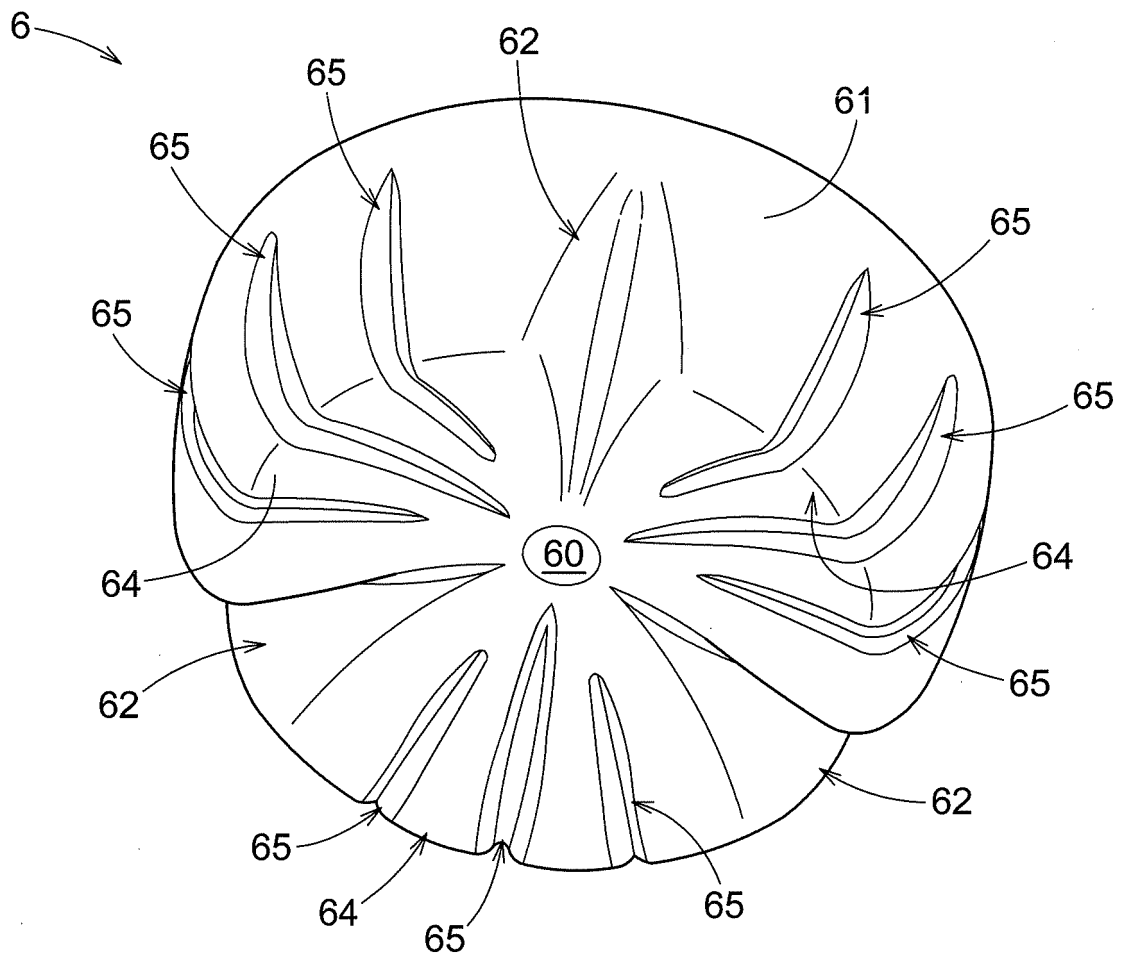

Fig.6



INTERNATIONAL SEARCH REPORT

International application No.
PCT/JP2020/002376

A. CLASSIFICATION OF SUBJECT MATTER		
B65D 1/02 (2006.01) i; B65D 1/42 (2006.01) i FI: B65D1/02 233; B65D1/42 According to International Patent Classification (IPC) or to both national classification and IPC		
B. FIELDS SEARCHED		
Minimum documentation searched (classification system followed by classification symbols) B65D1/02; B65D1/42		
Documentation searched other than minimum documentation to the extent that such documents are included in the fields searched		
Published examined utility model applications of Japan	1922-1996	
Published unexamined utility model applications of Japan	1971-2020	
Registered utility model specifications of Japan	1996-2020	
Published registered utility model applications of Japan	1994-2020	
Electronic data base consulted during the international search (name of data base and, where practicable, search terms used)		
C. DOCUMENTS CONSIDERED TO BE RELEVANT		
Category*	Citation of document, with indication, where appropriate, of the relevant passages	Relevant to claim No.
X	JP 2016-155603 A (NIAGARA BOTTLING, LLC) 01.09.2016 (2016-09-01) paragraphs [0037]-[0045], fig. 1-8	1-6
Y	paragraphs [0037]-[0045], fig. 1-8	2-6
X	US 2013/0213925 A1 (KRONES AG,) 22.08.2013 (2013- 08-22) paragraphs [0106]-[0119], fig. 5-14	1-6
Y	paragraphs [0106]-[0119], fig. 5-14	2-6
X	JP 2008-525278 A (ACQUA MINERALE S. BENEDETTO - S.P.A.) 17.07.2008 (2008-07-17) paragraphs [0009]- [0017], [0024]-[0027], fig. 1-7	1, 3-6
Y	paragraphs [0009]-[0017], [0024]-[0027], fig. 1-7	2-6
X	JP 2012-162287 A (DAINIPPON PRINTING CO., LTD.) 30.08.2012 (2012-08-30) paragraphs [0018]-[0023], [0031]-[0033], fig. 1-6	1-2
Y	paragraphs [0018]-[0023], [0031]-[0033], fig. 1-6	3-4, 6
A	US 2007/0045220 A1 (PLASTIPAK PACKAGING, INC.) 01.03.2007 (2007-03-01)	1-6
<input checked="" type="checkbox"/> Further documents are listed in the continuation of Box C.		<input checked="" type="checkbox"/> See patent family annex.
* Special categories of cited documents:		"J" later document published after the international filing date or priority date and not in conflict with the application but cited to understand the principle or theory underlying the invention
"A" document defining the general state of the art which is not considered to be of particular relevance		"X" document of particular relevance; the claimed invention cannot be considered novel or cannot be considered to involve an inventive step when the document is taken alone
"E" earlier application or patent but published on or after the international filing date		"Y" document of particular relevance; the claimed invention cannot be considered to involve an inventive step when the document is combined with one or more other such documents, such combination being obvious to a person skilled in the art
"L" document which may throw doubts on priority claim(s) or which is cited to establish the publication date of another citation or other special reason (as specified)		"&" document member of the same patent family
"O" document referring to an oral disclosure, use, exhibition or other means		
"P" document published prior to the international filing date but later than the priority date claimed		
Date of the actual completion of the international search 03 March 2020 (03.03.2020)	Date of mailing of the international search report 17 March 2020 (17.03.2020)	
Name and mailing address of the ISA/ Japan Patent Office 3-4-3, Kasumigaseki, Chiyoda-ku, Tokyo 100-8915, Japan	Authorized officer Telephone No.	

INTERNATIONAL SEARCH REPORT

International application No.
PCT/JP2020/002376

5
10
15
20
25
30
35
40
45
50
55

C (Continuation). DOCUMENTS CONSIDERED TO BE RELEVANT		
Category*	Citation of document, with indication, where appropriate, of the relevant passages	Relevant to claim No.
A	US 2010/0072165 A1 (SCHAU, Alexander) 25.03.2010 (2010-03-25)	1-6

INTERNATIONAL SEARCH REPORT
 Information on patent family members

International application No.

PCT/JP2020/002376

5
10
15
20
25
30
35
40
45
50
55

Patent Documents referred in the Report	Publication Date	Patent Family	Publication Date
JP 2016-155603 A	01 Sep. 2016	US 2015/0144587 A1 paragraphs [0047]- [0055], fig. 1-8 US 2014/0183156 A1 US 2014/0183202 A1 US 2018/0297741 A1 US 2015/0329234 A1 US 2019/0135477 A1 US 2015/0336703 A1 US 2019/0300229 A1 WO 2015/099813 A1 WO 2014/105956 A1 CA 2918903 A1 CA 2895524 A1	
US 2013/0213925 A1	22 Aug. 2013	US 2014/0238951 A1 US 2019/0322404 A1 DE 102012003219 A1	
JP 2008-525278 A	17 Jul. 2008	US 2007/0262046 A1 paragraphs [0025]- [0045], [0066]- [0074], fig. 1-7 WO 2006/067590 A1 CA 2591681 A1 (Family: none)	
JP 2012-162287 A	30 Aug. 2012	WO 2007/018584 A2	
US 2007/0045220 A1	01 Mar. 2007	EP 2163483 A1	
US 2010/0072165 A1	25 Mar. 2010	DE 102008047450 A1 CN 101708783 A	