

(19)



(11)

EP 3 991 594 A1

(12)

EUROPEAN PATENT APPLICATION

(43) Date of publication:
04.05.2022 Bulletin 2022/18

(51) International Patent Classification (IPC):
A45B 19/06 (2006.01)

(21) Application number: **21170834.2**

(52) Cooperative Patent Classification (CPC):
A45B 19/06; A45B 23/00; A45B 2023/0012;
A45B 2023/0031; A45B 2023/0037;
A45B 2023/005; A45B 2023/0062

(22) Date of filing: **28.04.2021**

(84) Designated Contracting States:
AL AT BE BG CH CY CZ DE DK EE ES FI FR GB GR HR HU IE IS IT LI LT LU LV MC MK MT NL NO PL PT RO RS SE SI SK SM TR
Designated Extension States:
BA ME
Designated Validation States:
KH MA MD TN

(72) Inventors:
• **Yang, Yi**
Linhai City Zhejiang 317004 (CN)
• **Wang, Tanguo**
Linhai City Zhejiang 317004 (CN)
• **Xie, Jianqiang**
Linhai City Zhejiang 317004 (CN)

(30) Priority: **28.10.2020 CN 202022440201 U**

(74) Representative: **Schulz Junghans**
Patentanwälte PartGmbH
Großbeerenstraße 71
10963 Berlin (DE)

(71) Applicant: **Yotrio Group Co., Ltd.**
Linhai City
Zhejiang 317004 (CN)

(54) **RIB ASSEMBLY THAT CAN BE PACKAGED RETRACTABLY FOR AN OUTDOOR UMBRELLA, AND AN OUTDOOR UMBRELLA**

(57) The present utility model discloses a rib assembly that can be packaged retractably for an outdoor umbrella, and an outdoor umbrella. The rib assembly comprises long ribs and short ribs. When disassembly and packaging are needed, the long ribs or/and the short ribs can be superimposed and contracted along the length direction. Locking mechanisms are arranged on the long ribs or/and the short ribs. When full extension is needed,

the long ribs or/and the short ribs are locked through the locking mechanisms. Through optimized design of the present utility model, the long ribs or/and the short ribs can achieve mutual contraction and superimposition, which can cause the rib assembly to be superimposed in volume during packaging, thereby significantly reducing the packaging volume and reducing the transport cost.

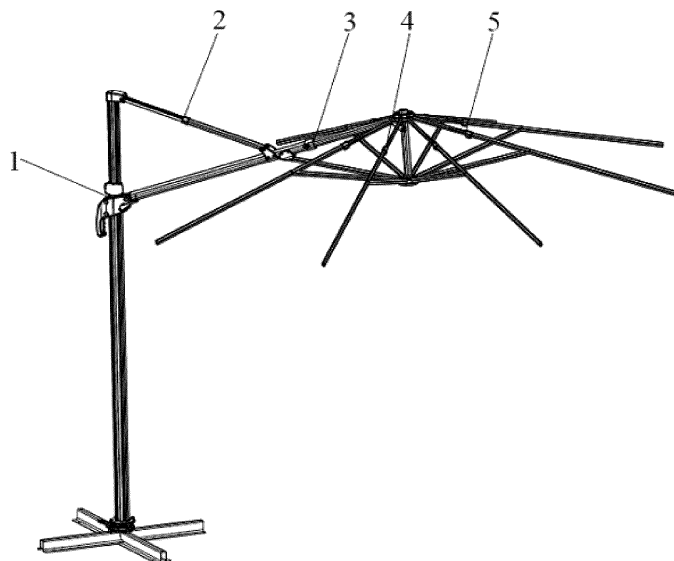

Fig. 1

EP 3 991 594 A1

Description

TECHNICAL FIELD

[0001] The present utility model relates to the technical field of outdoor umbrellas, particularly to a rib assembly that can be packaged retractably for an outdoor umbrella, and an outdoor umbrella.

BACKGROUND ART

[0002] Roman umbrellas are widely used in leisure places such as squares, beaches, parks and courtyards, providing people with comfortable leisure and cool spaces. A Roman umbrella generally comprises a base, an umbrella column, umbrella fabric, a pull rod, an umbrella runner and umbrella ribs, the umbrella column is used for erecting the umbrella and serves as a support pillar of the umbrella, the umbrella fabric generally covers the ribs, the contraction or extension of the entire umbrella is completed by folding or unfolding the ribs, and the pull rod is located between the ribs and the umbrella column and achieves connection and installation. Nevertheless, the existing outdoor umbrellas are large in size, resulting in a large external package and the problems of inconvenient transport and a large logistic cost.

SUMMARY OF THE UTILITY MODEL

[0003] An object of the present utility model is to provide a rib assembly that can be packaged retractably for an outdoor umbrella, and an outdoor umbrella to solve the foregoing technical problem. The present utility model can achieve the disassembly and contraction of the ribs, thereby significantly reducing the package volume.

[0004] The technical problem to be solved by the present utility model can be solved by the following technical solutions:

A rib assembly that can be packaged retractably for an outdoor umbrella is provided. The rib assembly comprises long ribs and short ribs. When disassembly and packaging are needed, the long ribs or/and the short ribs can be superimposed and contracted along the length direction. Locking mechanisms are arranged on the long ribs or/and short ribs, and when full extension is needed, the long ribs or/and the short ribs are locked through the locking mechanisms.

[0005] The short ribs comprise short rib bodies and short retractable ribs, and the short retractable ribs can be fully or partially superimposed and contracted in the cavities of the short rib bodies.

[0006] The short ribs adopt single-pole structures and the long ribs can be superimposed and contracted along the length direction.

[0007] The long ribs comprise long rib bodies and long retractable ribs, and the long retractable ribs can be fully or partially superimposed and contracted in the cavities of the long rib bodies.

[0008] The locking mechanisms may adopt any one of lockpin locking mechanisms, spring bean locking mechanisms, thread tightening and locking mechanisms or handle friction locking mechanisms.

5 [0009] The locking mechanisms adopt lockpin locking mechanisms, one end of each of the short retractable ribs or/and the long retractable ribs is provided with an inner lockhole, one end of each of the short rib bodies or/and the long rib bodies is provided with an outer lockhole, and the inner lockhole and the outer lockhole complete locking through a lockpin.

10 [0010] The locking mechanisms adopt spring bean locking mechanisms, an inner cavity at one end of each of the short retractable ribs or/and the long retractable ribs is provided with a spring bean piece, the short retractable ribs or/and the long retractable ribs are provided with inner spring bean orifices accordingly, the short rib bodies or/and the long rib bodies are provided with outer spring bean orifices accordingly, and convex portions of the spring bean pieces are used to work with the inner spring bean orifices and the outer spring bean orifices and can achieve locking and unlocking.

15 [0011] One end of each of the long retractable ribs is used for articulated fit with an upper umbrella runner, and the other end is used for abutted fit with a long rib body.

20 [0012] The number of the long retractable ribs is two, which are located at two ends of the long rib bodies.

25 [0013] An outdoor umbrella with a rib assembly that can be packaged retractably is provided, which comprises the rib assembly in any of the preceding paragraphs, and is a side umbrella or a patio umbrella.

30 [0014] Compared with the prior art, the present utility model has the following outstanding advantages and effects: Through optimized design of the present utility model, long ribs or/and short ribs can achieve mutual contraction and superimposition, which can cause the rib assembly to be superimposed in volume during packaging, thereby significantly reducing the packaging volume and reducing the transport cost.

35 [0015] The features of the present utility model can be made more evident with reference to the accompanying drawings and detailed description of preferred embodiments of the present utility model.

45 BRIEF DESCRIPTION OF THE DRAWINGS

[0016]

50 Fig. 1 is a structural schematic view 1 of overall installation in the present utility model;

Fig. 2 is a structural schematic view 1 of a rib assembly provided by the present utility model;

55 Fig. 3 is a structural schematic view 1 of an umbrella column provided by the present utility model in an extended state;

Fig. 4 is a structural schematic view of the umbrella column provided by the present utility model in a contracted state;

Fig. 5 is a structural schematic view of a first pull rod provided by the present utility model in an extended state;

Fig. 6 is a structural schematic view of the first pull rod provided by the present utility model in a contracted state;

Fig. 7 is a structural schematic view of a second pull rod provided by the present utility model in an extended state;

Fig. 8 is a structural schematic view of the second pull rod provided by the present utility model in a contracted state;

Fig. 9 is a structural schematic view 1 of a long rib provided by the present utility model in an extended state;

Fig. 10 is a structural schematic view of a short rib provided by the present utility model in an extended state;

Fig. 11 is a structural schematic view 2 of overall installation in the present utility model;

Fig. 12 is a structural schematic view 2 of the umbrella column provided by the present utility model in an extended state;

Fig. 13 is a structural schematic view 2 of a long rib provided by the present utility model in an extended state;

Fig. 14 is a structural schematic view 2 of a rib assembly provided by the present utility model;

Fig. 15 is a structural schematic view 1 of a locking mechanism provided by the present utility model;

Fig. 16 is a structural schematic view 2 of a locking mechanism provided by the present utility model;

Fig. 17 is a structural schematic view 3 of a locking mechanism provided by the present utility model;

Fig. 18 is a structural schematic view 4 of a locking mechanism provided by the present utility model;

[0017] In the figures, 1-umbrella column; 11-umbrella column body; 12-retractable umbrella column; 2-first pull rod; 21-first pull rod body; 22-first retractable pull rod; 3-second pull rod; 31-second pull rod body; 32-second re-

tractable pull rod; 4-long rib; 41-long rib body; 42-long retractable rib; 5-short rib; 51-short rib body; 52-short retractable rib; 6-locking mechanism.

5 DETAILED DESCRIPTION

[0018] In order to make the technical means, creative features and achieved objects and effects of the present utility model easy to understand, the present utility model is further illustrated with reference to specific drawings.

Embodiment 1

[0019] As shown in the figures, the present utility model provides a rib assembly that can be packaged retractably for an outdoor umbrella. The rib assembly is suitable for use in a patio umbrella or a side umbrella. In general, the rib assembly is also provided with umbrella fabric and comprises long ribs 4 and short ribs 5. When disassembly and packaging are needed, the long ribs 4 or/and the short ribs 5 can be superimposed and contracted along the length direction. Locking mechanisms 6 are arranged on the long ribs 4 or/and the short ribs 5, and when full extension is needed, the long ribs 4 or/and the short ribs 5 are locked through the locking mechanisms 6.

[0020] Through optimized design of the present utility model, the long ribs 4 or/and the short ribs 5 can achieve mutual contraction and superimposition, which can cause the rib assembly to be superimposed in volume during packaging, thereby significantly reducing the packaging volume and reducing the transport cost.

[0021] Preferably, the short ribs 5 comprise short rib bodies 51 and short retractable ribs 52, and the short retractable ribs 52 can be fully or partially superimposed and contracted in the cavities of the short rib bodies 51.

[0022] In a preferred embodiment, the short ribs 5 adopt single-pole structures, and the long ribs 4 can be superimposed and contracted along the length direction.

[0023] Here, the long ribs 4 comprise long rib bodies 41 and long retractable ribs 42, and the long retractable ribs 42 can be fully or partially superimposed and contracted in the cavities of the long rib bodies 41.

[0024] In a preferred embodiment, the number of the long retractable ribs 42 is two, which are located at two ends of the long rib bodies 41 and can achieve contraction of the two ends.

[0025] Here, the locking mechanisms 6 may adopt any one of lockpin locking mechanisms, spring bean locking mechanisms, thread tightening and locking mechanisms or handle friction locking mechanisms.

[0026] In a preferred embodiment, the locking mechanisms 6 adopt lockpin locking mechanisms. A lockpin locking mechanism 6 generally comprises a lockpin piece 61A, a lockpin button 62A, a reset spring 63A and a mounting base 64A. The mounting base 64A is mounted in an end position of a short rib body 51 or/and a long rib body 41 in a sheathed manner and is used for mounting the lockpin piece 61A, the lockpin button 62A and the

reset spring 63A. The lockpin button 62A is used for driving the lockpin piece 61A to move and can be reset through the reset spring 63A. One end of each of the short retractable ribs 52 or/and the long retractable ribs 42 is provided with an inner lockhole, one end of each of the short rib bodies 51 or/and long rib bodies 41 is provided with an outer lockhole, and the inner lockhole and the outer lockhole complete locking through a lockpin.

[0027] In a preferred embodiment, the locking mechanisms 6 adopt spring bean locking mechanisms. A spring bean piece 61B is arranged in a cavity at one end of each of the short retractable ribs 52 or/and the long retractable ribs 42, the short retractable ribs 52 or/and the long retractable ribs 42 are provided with inner spring bean orifices accordingly, the short rib bodies 51 or/and the long rib bodies 41 are provided with outer spring bean orifices accordingly, and convex portions of the spring bean pieces are used to work with the inner spring bean orifices and the outer spring bean orifices and can achieve locking and unlocking.

[0028] Based on any of the foregoing embodiments, in a preferred embodiment, the locking mechanisms 6 adopt thread tightening and locking mechanisms, each of which generally comprises an upper thread bushing 61C and a lower thread bushing 62C, and the upper thread bushing 61C and the lower thread bushing 62C can rotate to achieve locking after abutting.

[0029] Based on any of the foregoing embodiments, in a preferred embodiment, the locking mechanisms 6 adopt handle friction locking mechanisms, each of which generally comprises a fixed seat 61D and a cam trigger 62D. A cam is arranged on the cam trigger 62D and locking is achieved by means of the extrusion and friction of the cam.

Embodiment 2

[0030] Based on Embodiment 1, this embodiment provides a patio umbrella comprising a rib assembly that can be packaged retractably, and comprises an umbrella column 1 and the rib assembly. The umbrella column 1 preferably is a round-tube umbrella column 1 and generally is used for cooperative installation of an upper umbrella runner and a lower umbrella runner. The rib assembly comprises long ribs 4 and short ribs 5. The umbrella column 1 can be extended and contracted along the length direction. The long ribs 4 or/and the short ribs 5 can be extended and contracted along the length direction. When an outdoor umbrella stand needs to be assembled, the umbrella column 1, the long ribs 4 and the short ribs 5 are all in an extended and fixed state; and when the outdoor umbrella stand needs to be disassembled and packaged, any one or more of the umbrella column 1, the long ribs 4 and the short ribs 5 are in a contracted state.

[0031] In a preferred embodiment, the umbrella column 1, the long ribs 4 and the short ribs 5 all adopt a design of retractable structures.

[0032] In a preferred embodiment, the umbrella column 1 and the long ribs 4 adopt a design of retractable structures, and the short ribs 5 adopt single-rib structures.

5 **[0033]** In a preferred embodiment, the umbrella column 1 adopts a retractable structure including at least two sections, preferably adopts a two-section retractable structure, and alternatively, may adopt a three-section or
10 four-section retractable structure; the umbrella column 1 comprises an umbrella column body 11 and a retractable umbrella column 12, the retractable umbrella column 12 is located in the upper part and/or lower part of the umbrella column body 11, and the retractable umbrella column 12 can fit the umbrella column body 11 in a retractable manner. The retractable umbrella column 12 generally is smaller than the umbrella column body 11 in size, and can be contracted and superimposed in a cavity of the umbrella column body 11; the retractable umbrella column 12 comprises at least one retractable umbrella column unit and alternatively, may comprise a plurality of retractable umbrella column units, preferably one retractable umbrella column unit; in an embodiment, the retractable umbrella column 12 is located in the upper part of the umbrella column body 11; in an embodiment, there are two retractable umbrella columns 12, located in the upper part and the lower part of the umbrella column body 11, respectively.

20 **[0034]** In a preferred embodiment, the long ribs 4 adopt retractable structures including at least two sections, preferably adopt two-section retractable structures, and alternatively, may adopt three-section or four-section retractable structures; the long ribs 4 comprise long rib bodies 41 and long retractable ribs 42. One end of each of the long retractable ribs 42 is used for articulated fit with
25 an upper umbrella runner, and the other end of the long retractable rib 42 is used for retractable abutting with a long rib body 41; the long retractable rib 42 generally is smaller than the long rib body 41 in size and can be contracted and superimposed in a cavity of the long rib body 41; the long retractable rib 42 comprises at least one long retractable rib unit and alternatively, may comprise a plurality of long retractable rib units, preferably one long retractable rib.

30 **[0035]** In a preferred embodiment, the short ribs 5 adopt retractable structures including at least two sections, preferably adopt two-section retractable structures, and alternatively, may adopt three-section or four-section retractable structures; the short ribs 5 comprise short rib bodies 51 and short retractable ribs 52. One end of each of the short retractable ribs 52 is used for articulated fit with a lower umbrella runner, the other end of the short retractable rib 52 is used for retractable abutting with one end of a short rib body 51, and the other end of the short rib body 51 is used for articulated fit with a long
35 rib 4; the short retractable rib 52 generally is smaller than the short rib body 51 and can be contracted and superimposed in a cavity of the short rib body 51; the short retractable rib 52 comprises at least one short retractable

rib unit and alternatively, may comprise a plurality of short retractable rib units, preferably one short retractable rib unit.

[0036] Here, when any one of the umbrella column 1, the long ribs 4 and the short ribs 5 can be extended and contracted along the length direction, extension or contraction and locking can be achieved through locking mechanisms.

[0037] Through optimized design of the present utility model, a retracting and superimposing structure can be used to achieve superimposition of component volume between the umbrella column and the rib assembly, thereby significantly reducing the overall volume and reducing the packaging volume and the transport cost.

[0038] In the actual packaging process, for a patio umbrella of the same pattern, if a retractable umbrella stand is adopted, the packaging volume of a single umbrella can be reduced by 25% to 35% compared with a conventional umbrella stand.

Embodiment 3

[0039] Based on Embodiment 1, this embodiment provides a side umbrella comprising a rib assembly that can be packaged retractably, and comprises an umbrella column 1, a pull rod assembly and a rib assembly. The pull rod assembly comprises a first pull rod 2 and a second pull rod 3. The rib assembly comprises long ribs 4 and short ribs 5. The umbrella column 1 can be extended and contracted along the length direction. One or more of the first pull rod 2, the second pull rod 3, the long ribs 4 and the short ribs 5 can be extended and contracted along the length direction. When an outdoor umbrella stand needs to be assembled, the umbrella column 1, the first pull rod 2, the second pull rod 3, the long ribs 4 and the short ribs 5 are all in an extended and fixed state; and when the outdoor umbrella stand needs to be disassembled and packaged, any one or more of the umbrella column 1, the first pull rod 2, the second pull rod 3, the long ribs 4 and the short ribs 5 are in a contracted state.

[0040] Based on the above, the outdoor umbrella stand is preferably a Roman umbrella stand and alternatively, may be a banana umbrella stand, a push rod umbrella stand, etc.

[0041] In a preferred embodiment, the umbrella column 1, the first pull rod 2, the second pull rod 3, the long ribs 4 and the short ribs 5 all adopt a design of retractable structures.

[0042] In a preferred embodiment, the umbrella column 1, the first pull rod 2, the second pull rod 3 and the long ribs 4 adopt a design of retractable structures, and the short ribs 5 adopt single-rib structures.

[0043] In a preferred embodiment, the umbrella column 1, the second pull rod 3 and the long ribs 4 adopt a design of retractable structures, the short ribs 5 adopt single-rib structures, and the first pull rod 2 adopts an ordinary pull rod structure.

[0044] In a preferred embodiment, the umbrella col-

umn 1, the long ribs 4 and the short ribs 5 adopt a design of retractable structures, and the first pull rod 2 and the second pull rod 3 adopt ordinary pull rod structures.

[0045] In a preferred embodiment, the umbrella column 1 and the long ribs 4 adopt a design of retractable structures, and the first pull rod 2, the second pull rod 3 and the short ribs 5 adopt ordinary pull rod structures.

[0046] In a preferred embodiment, the umbrella column 1 adopts a retractable structure including at least two sections, preferably adopts a two-section retractable structure, and alternatively, may adopt a three-section or four-section retractable structure; the umbrella column 1 comprises an umbrella column body 11 and a retractable umbrella column 12, the retractable umbrella column 12 is located in the upper part and/or lower part of the umbrella column body 11, and the retractable umbrella column 12 can fit the umbrella column body 11 in a retractable manner. The retractable umbrella column 12 generally is smaller than the umbrella column body 11 in size, and can be contracted and superimposed in a cavity of the umbrella column body 11; the retractable umbrella column 12 comprises at least one retractable umbrella column unit and alternatively, may comprise a plurality of retractable umbrella column units, preferably one retractable umbrella column unit; in an embodiment, the retractable umbrella column 12 is located in the upper part of the umbrella column body 11; in an embodiment, there are two retractable umbrella columns 12, located in the upper part and the lower part of the umbrella column body 11, respectively.

[0047] Here, any one or more of the first pull rod 2, the second pull rod 3, the long ribs 4 and the short ribs 5 adopt retractable structures including at least two sections.

[0048] In a preferred embodiment, the first pull rod 2 adopts a retractable structure including at least two sections, preferably adopts a two-section retractable structure, and alternatively, may adopt a three-section or four-section retractable structure; the first pull rod 2 comprises a first pull rod body 21 and a first retractable pull rod 22, one end of the first retractable pull rod 22 is used for articulated fit with the retractable umbrella column 12, the other end of the first retractable pull rod 22 is abutted with one end of the first pull rod body 21 in a retractable manner, and the other end of the first pull rod body 21 is used for articulated fit with the second pull rod 3; the first retractable pull rod 22 generally is smaller than the first pull rod body 21 in size and can be retracted and superimposed in a cavity of the first pull rod body 21; the first retractable pull rod 22 comprises at least one first retractable pull rod unit and alternatively, may comprise a plurality of the first retractable pull rod units, preferably one first retractable pull rod unit.

[0049] In a preferred embodiment, the second pull rod 3 adopts a retractable structure including at least two sections, preferably adopts a two-section retractable structure, and alternatively, may adopt a three-section or four-section retractable structure; the second pull rod 3

comprises a second pull rod body 31 and a second retractable pull rod 32, one end of the second retractable pull rod 32 is used for articulated fit with an upper umbrella runner, the other end of the second retractable pull rod 32 is abutted with one end of the second pull rod body 31 in a retractable manner, and the other end of the second pull rod body 31 is used for articulated fit with a handle casing; the second retractable pull rod 32 generally is smaller than the second pull rod body 31 in size and can be retracted and superimposed in a cavity of the second pull rod body 31; the second retractable pull rod 32 comprises at least one second retractable pull rod unit and alternatively, may comprise a plurality of the second retractable pull rod units, preferably one second retractable pull rod unit.

[0050] In a preferred embodiment, the long ribs 4 adopt retractable structures including at least two sections, preferably adopt two-section retractable structures, and alternatively, may adopt three-section or four-section retractable structures; the long ribs 4 comprise long rib bodies 41 and long retractable ribs 42, one end of each of the long retractable ribs 42 is used for articulated fit with an upper umbrella runner, and the other end of the long retractable rib 42 is used for retractable abutting with a long rib body 41; the long retractable rib 42 generally is smaller than the long rib body 41 in size and can be retracted and superimposed in a cavity of the long rib body 41; the long retractable rib 42 comprises at least one long retractable rib unit and alternatively, may comprise a plurality of long retractable rib units, preferably one long retractable rib.

[0051] In a preferred embodiment, the short ribs 5 adopt retractable structures including at least two sections, preferably adopt two-section retractable structures, and alternatively, may adopt three-section or four-section retractable structures; the short ribs 5 comprise short rib bodies 51 and short retractable ribs 52, one end of each of the short retractable ribs 52 is used for articulated fit with a lower umbrella runner, the other end of the short retractable rib 52 is used for retractable abutting with one end of a short rib body 51, and the other end of the short rib body 51 is used for articulated fit with a long rib 4; the short retractable rib 52 generally is smaller than the short rib body 51 and can be retracted and superimposed in a cavity of the short rib body 51; the short retractable rib 52 comprises at least one short retractable rib unit and alternatively, may comprise a plurality of short retractable rib units, preferably one short retractable rib unit.

[0052] Here, when any one of the umbrella column 1, the first pull rod 2, the second pull rod 3, the long ribs 4 and the short ribs 5 can be extended and contracted along the length direction, extension or contraction and locking can be achieved through locking mechanisms.

[0053] Through optimized design of the present utility model, a retracting and superimposing structure can be used to achieve superimposition of component volume between the umbrella column, the pull rod assembly and

the rib assembly, thereby significantly reducing the overall volume and reducing the packaging volume and transport cost.

[0054] In the actual packaging process, for a Roman umbrella of the same pattern, if a retractable umbrella stand is adopted, the packaging volume of a single umbrella can be reduced by 30% to 45% compared with a conventional umbrella stand.

[0055] From the technical common knowledge, it can be known that the present utility model can be implemented by other embodiments without departing from the spirit or necessary features of the present utility model. Therefore, the foregoing disclosed embodiments, in all respects, are just examples and not the only ones. All changes within the scope of the present utility model or equivalently within the scope of the present utility model are included in the present utility model.

Claims

1. A rib assembly that can be packaged retractably for an outdoor umbrella, comprising long ribs (4) and short ribs (5), wherein when disassembly and packaging are needed, the long ribs (4) or/and the short ribs (5) can be superimposed and contracted along the length direction; locking mechanisms (6) are arranged on the long ribs (4) or/and the short ribs (5), and when full extension is needed, the long ribs (4) or/and the short ribs (5) are locked through the locking mechanisms (6).
2. The rib assembly that can be packaged retractably for an outdoor umbrella according to claim 1, wherein the short ribs (5) comprise short rib bodies (51) and short retractable ribs (52), and the short retractable ribs (52) can be fully or partially superimposed and contracted in cavities of the short rib bodies (51).
3. The rib assembly that can be packaged retractably for an outdoor umbrella according to claim 1, wherein the short ribs (15) adopt single-pole structures and the long ribs (4) can be superimposed and contracted along the length direction.
4. The rib assembly that can be packaged retractably for an outdoor umbrella according to claim 1 or 3, wherein the long ribs (4) comprise long rib bodies (41) and long retractable ribs (42), and the long retractable ribs (42) can be fully or partially superimposed and contracted in cavities of the long rib bodies (41).
5. The rib assembly that can be packaged retractably for an outdoor umbrella according to claim 1, wherein the locking mechanisms (6) may adopt any one of lockpin locking mechanisms, spring bean locking mechanisms, thread tightening and locking mecha-

nisms or handle friction locking mechanisms.

6. The rib assembly that can be packaged retractably for an outdoor umbrella according to claim 1, wherein the locking mechanisms (6) adopt lockpin locking mechanisms, one end of each of the short retractable ribs (52) or/and the long retractable ribs (42) is provided with an inner lockhole, one end of each of the short rib bodies (51) or/and the long rib bodies (41) is provided with an outer lockhole, and the inner lockhole and the outer lockhole complete locking through a lockpin. 5
10
7. The rib assembly that can be packaged retractably for an outdoor umbrella according to claim 1, wherein the locking mechanisms (6) adopt spring bean locking mechanisms, a spring bean piece is arranged in the cavity at one end of each of the short retractable ribs (52) or/and the long retractable ribs (41), the short retractable ribs (52) or/and the long retractable ribs (42) are provided with inner spring bean orifices accordingly, the short rib bodies (51) or/and the long rib bodies (41) are provided with outer spring bean orifices accordingly, and convex portions of the spring bean pieces are used to work with the inner spring bean orifices and the outer spring bean orifices and can achieve locking and unlocking. 15
20
25
8. The rib assembly that can be packaged retractably for an outdoor umbrella according to claim 4, wherein one end of each of the long retractable ribs (42) is used for articulated fit with an upper umbrella runner and the other end is used for abutted fit with a long rib body (41). 30
35
9. The rib assembly that can be packaged retractably for an outdoor umbrella according to claim 4, wherein the number of the long retractable ribs (42) is two, which are located at two ends of the long rib bodies (41). 40
10. An outdoor umbrella with a rib assembly that can be packaged retractably, wherein the outdoor umbrella comprises the rib assembly in any of the above claims and is a side umbrella or a patio umbrella. 45

50

55

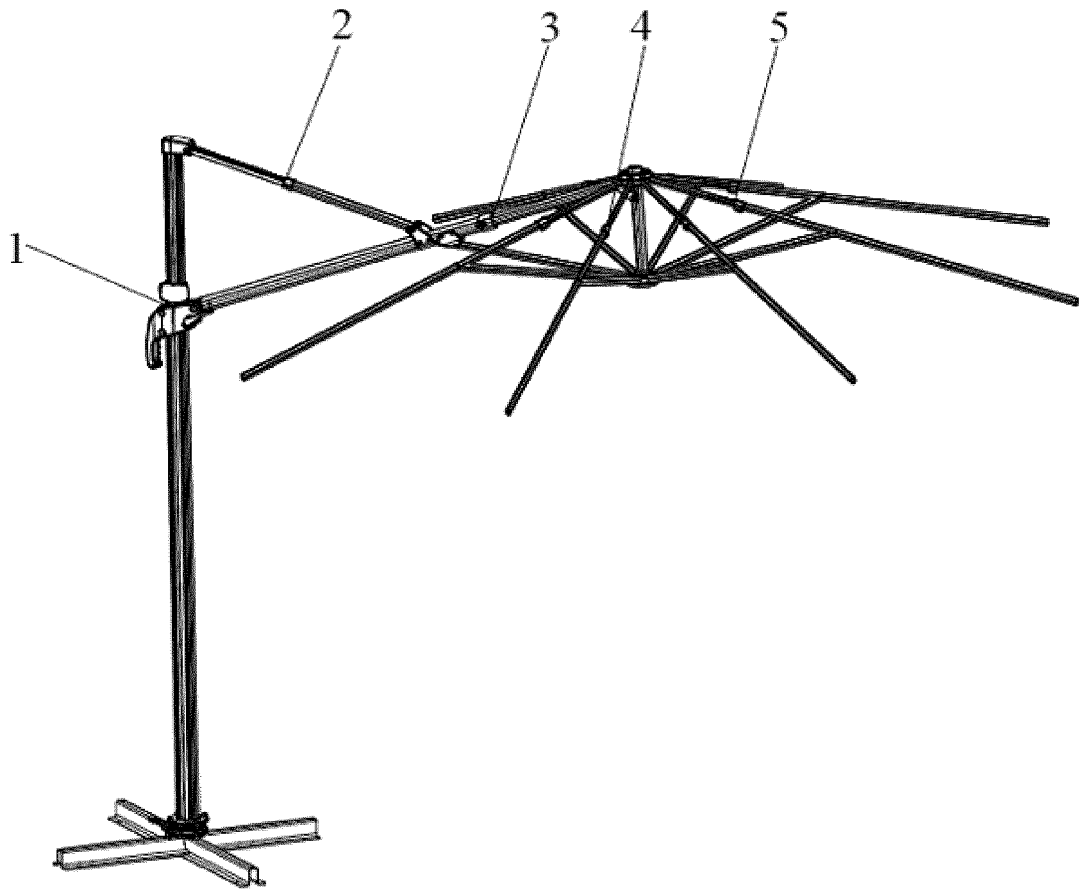

Fig. 1

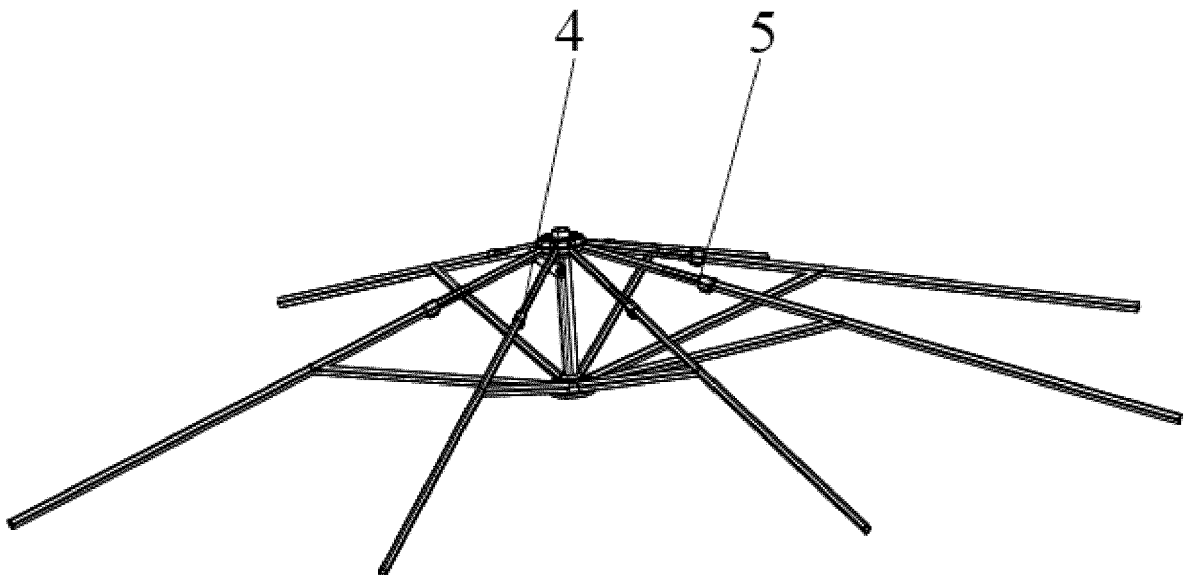

Fig. 2

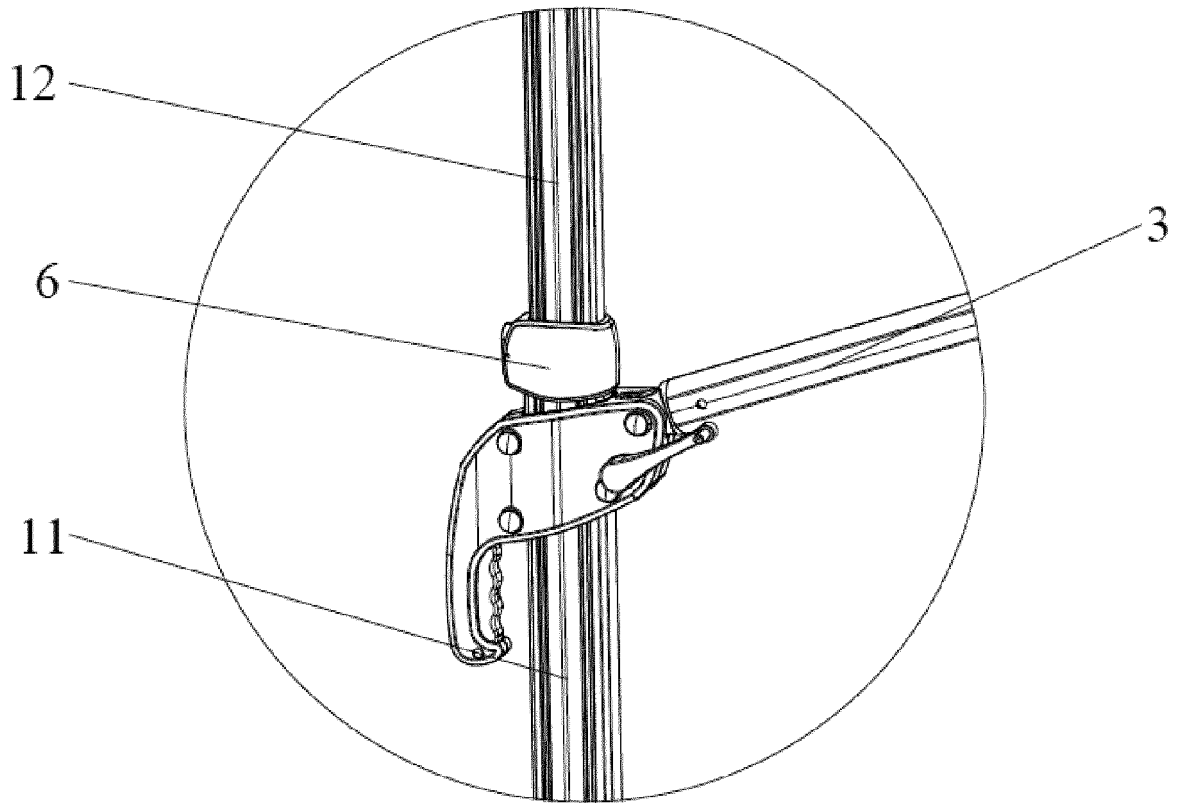

Fig. 3

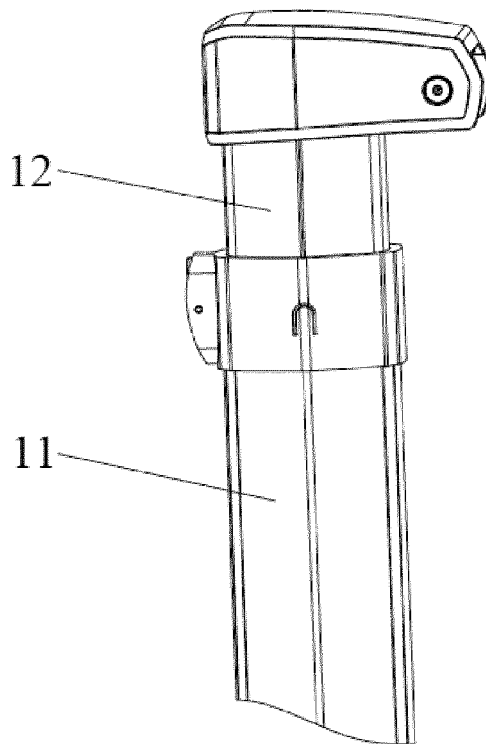

Fig. 4

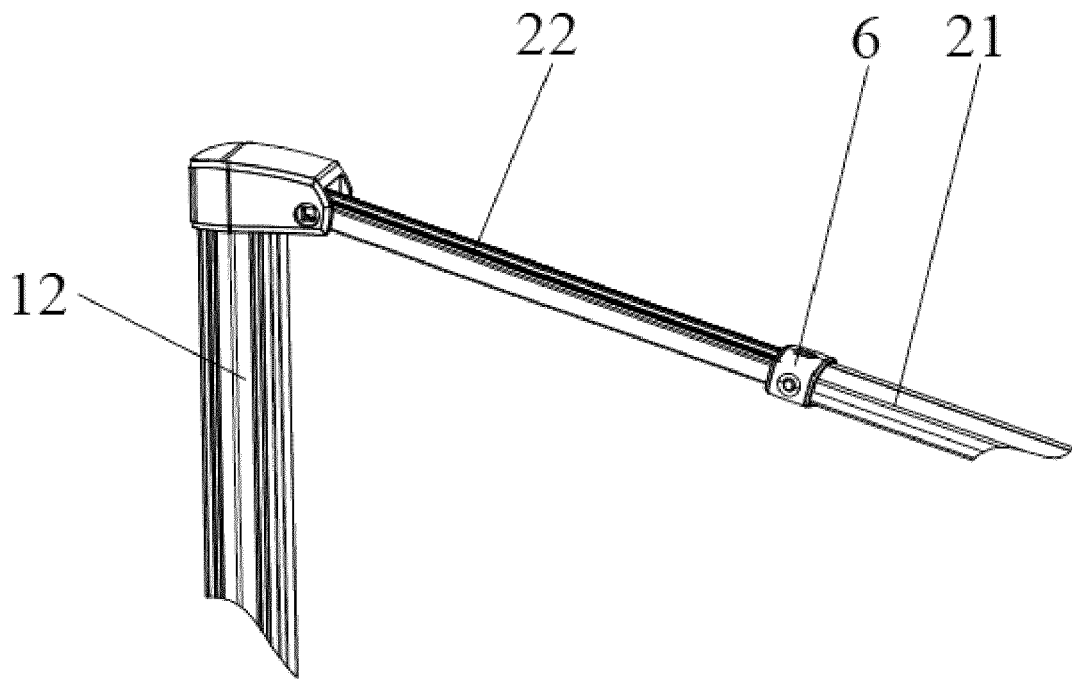

Fig. 5

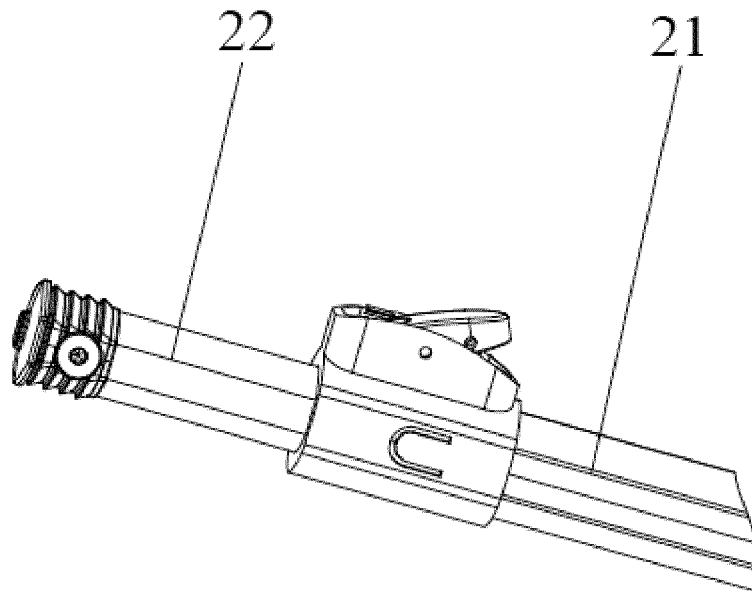

Fig. 6

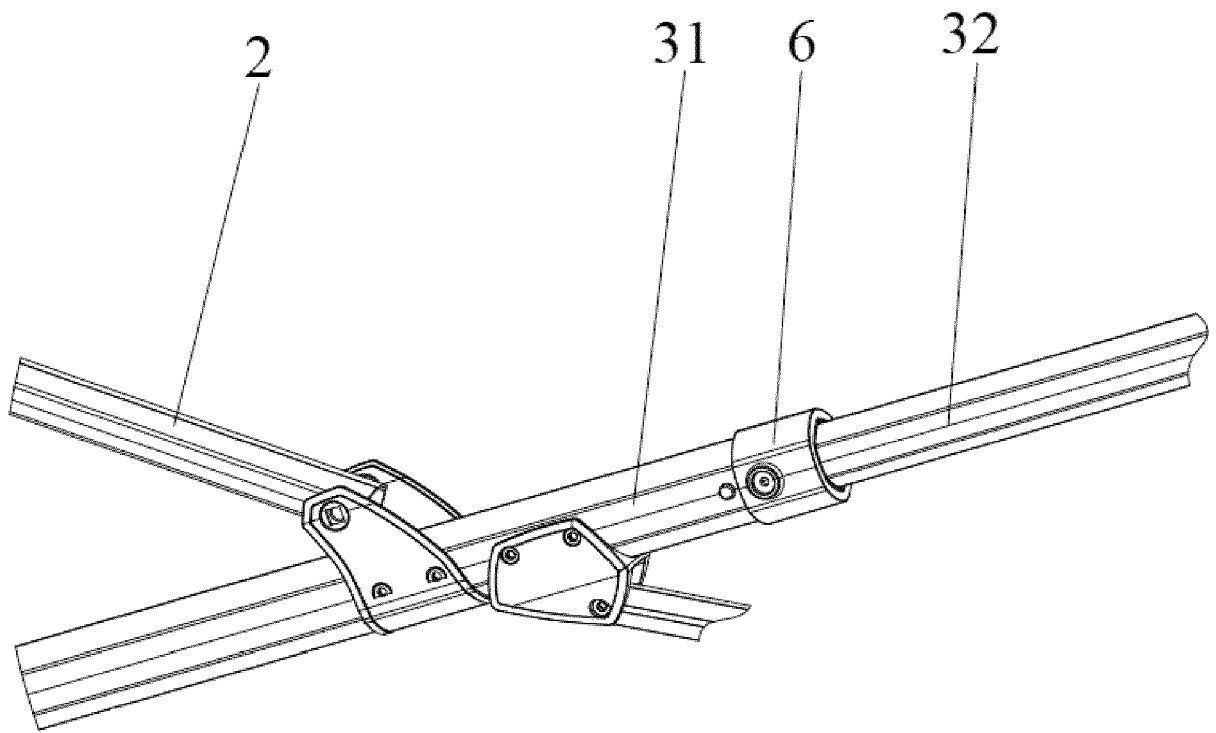

Fig. 7

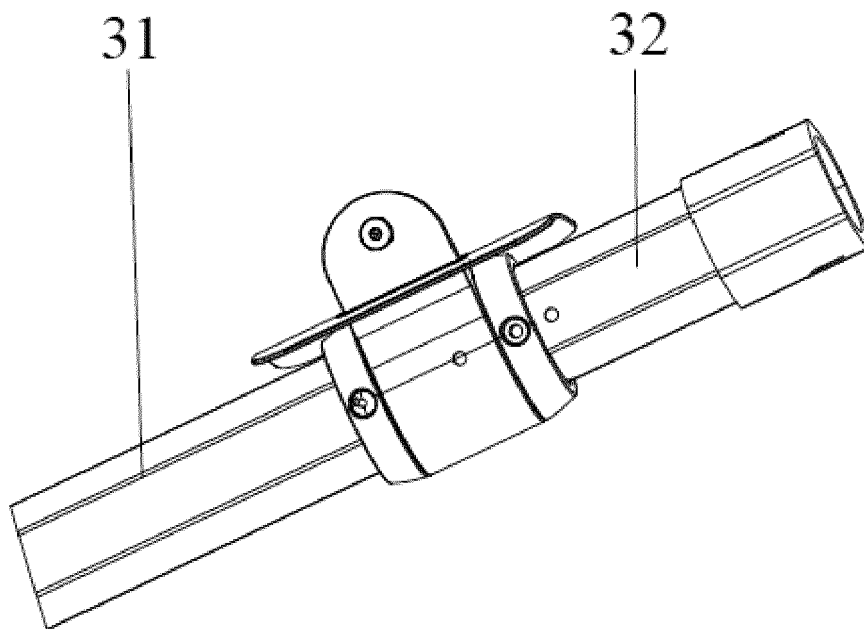

Fig. 8

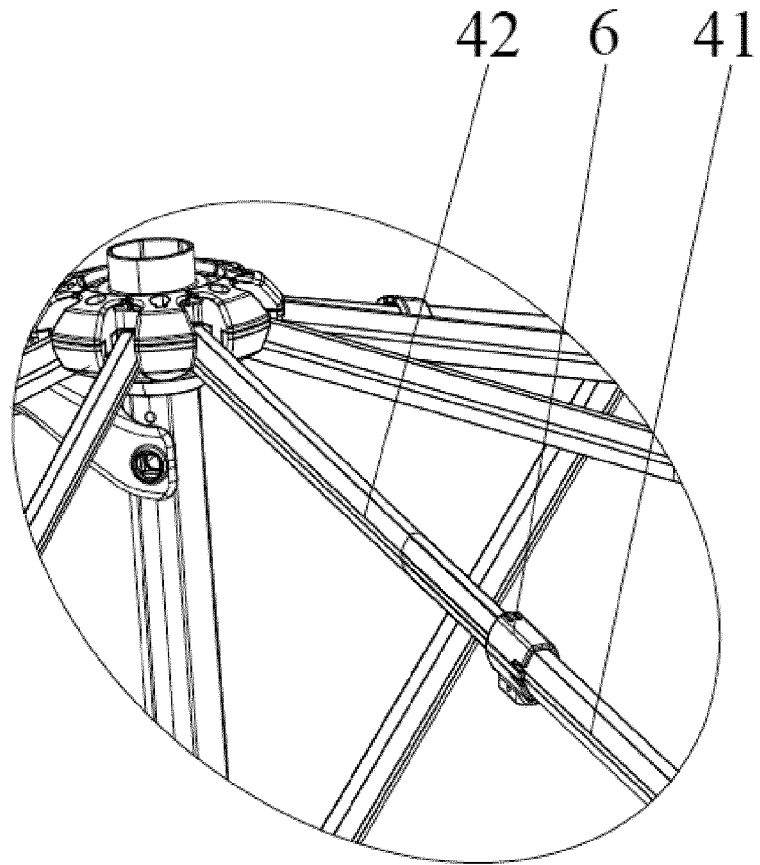

Fig. 9

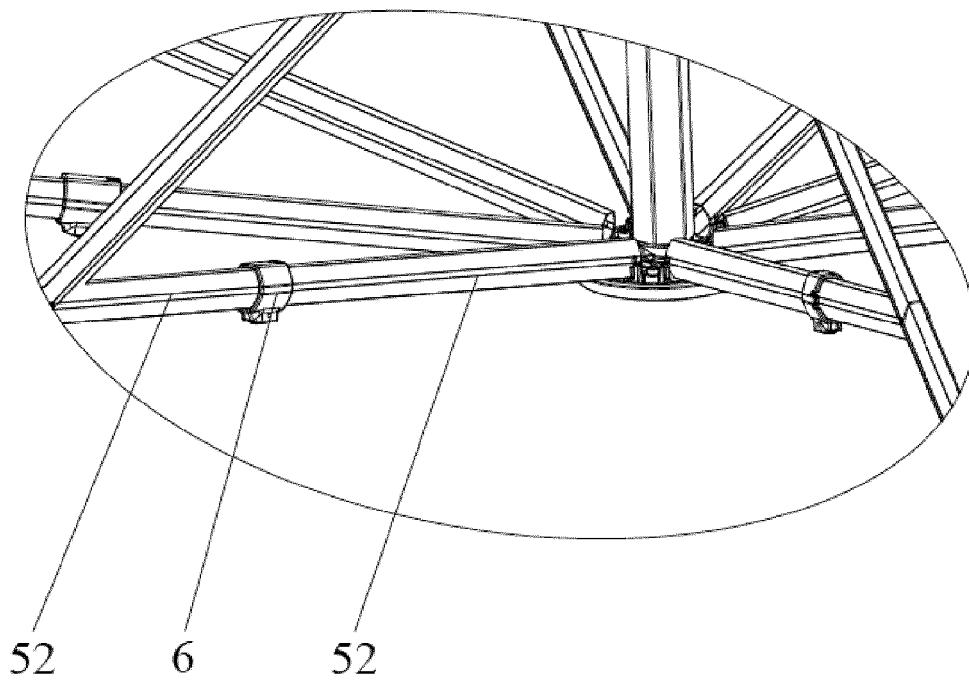

Fig. 10

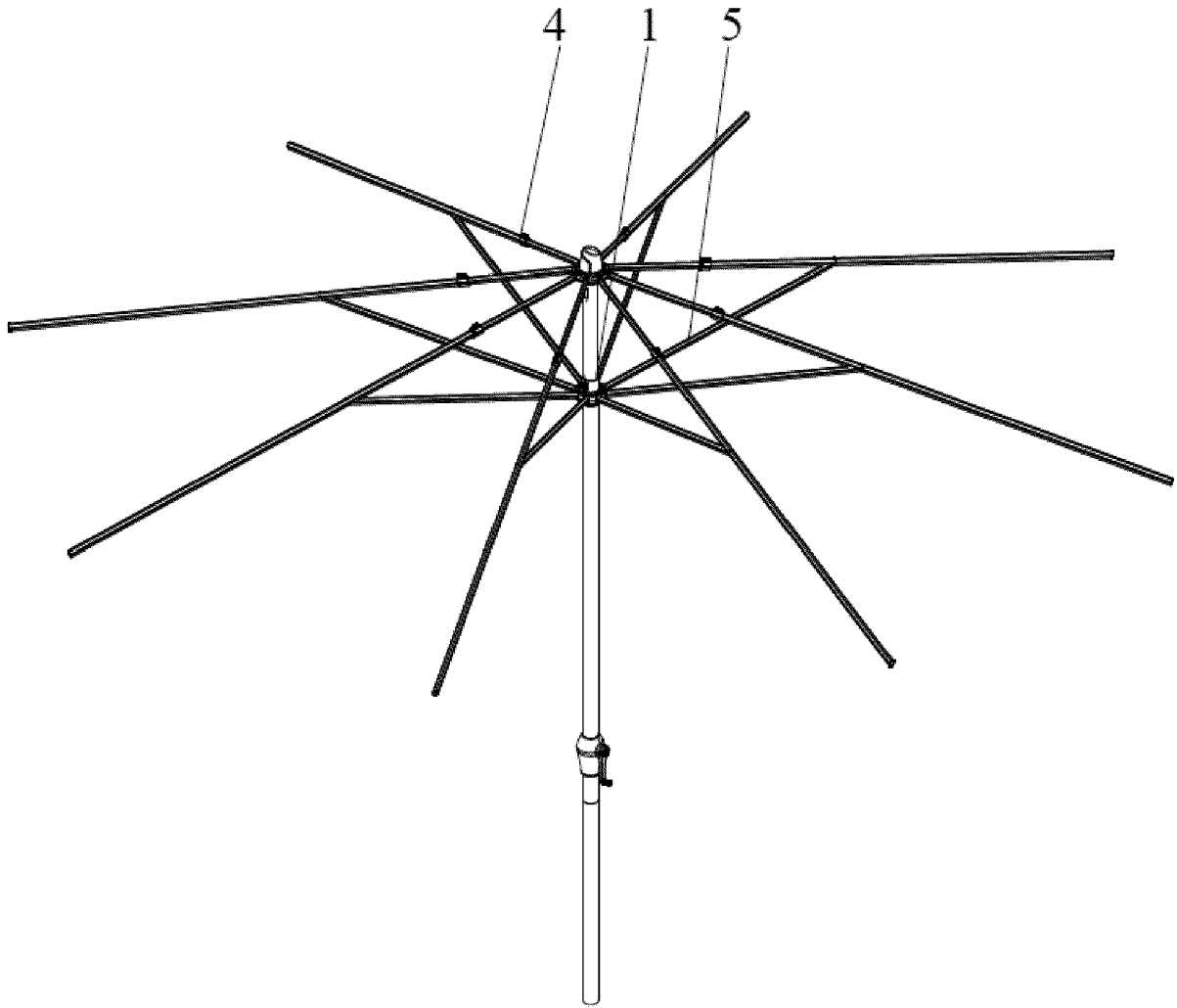

Fig. 11

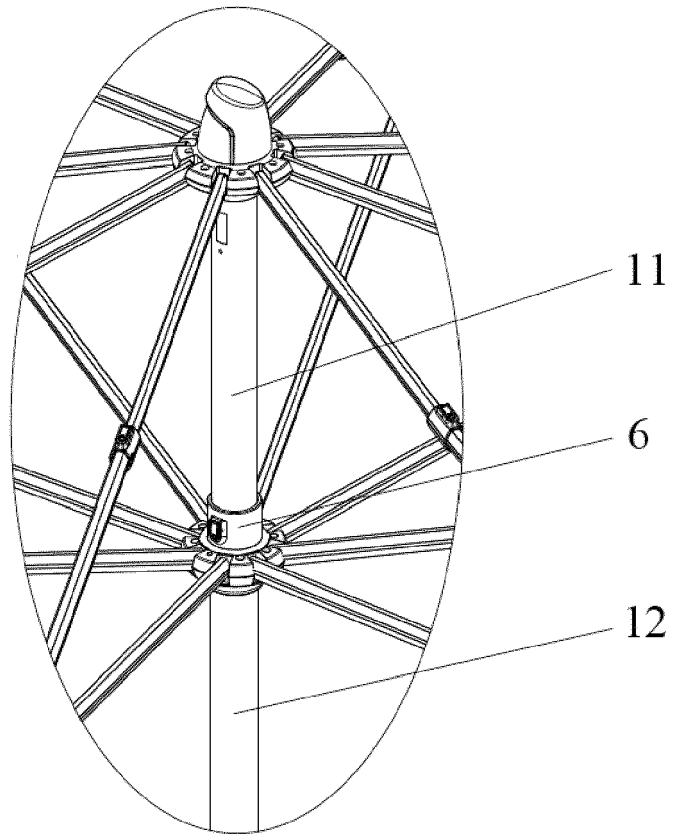

Fig. 12

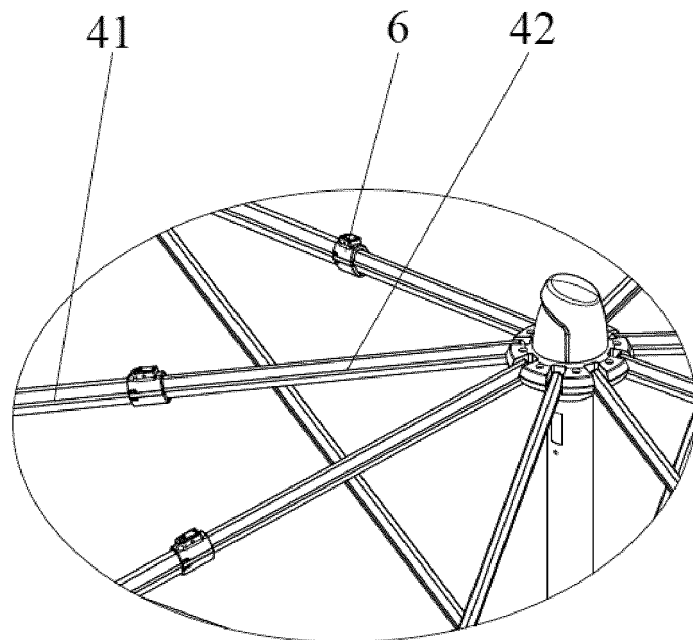

Fig. 13

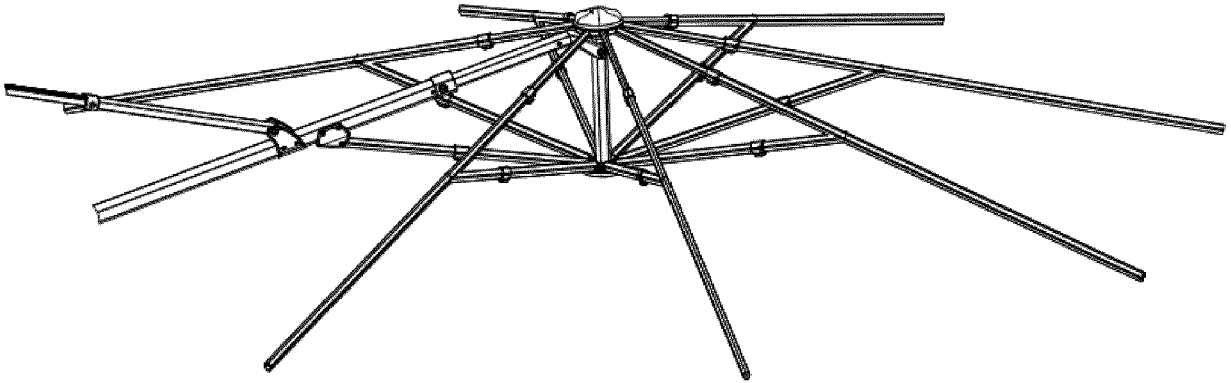

Fig. 14

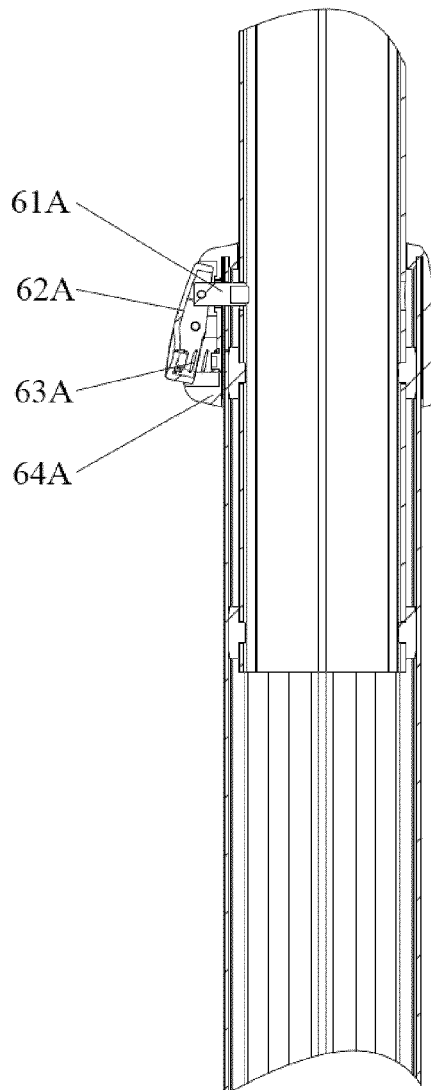

Fig. 15

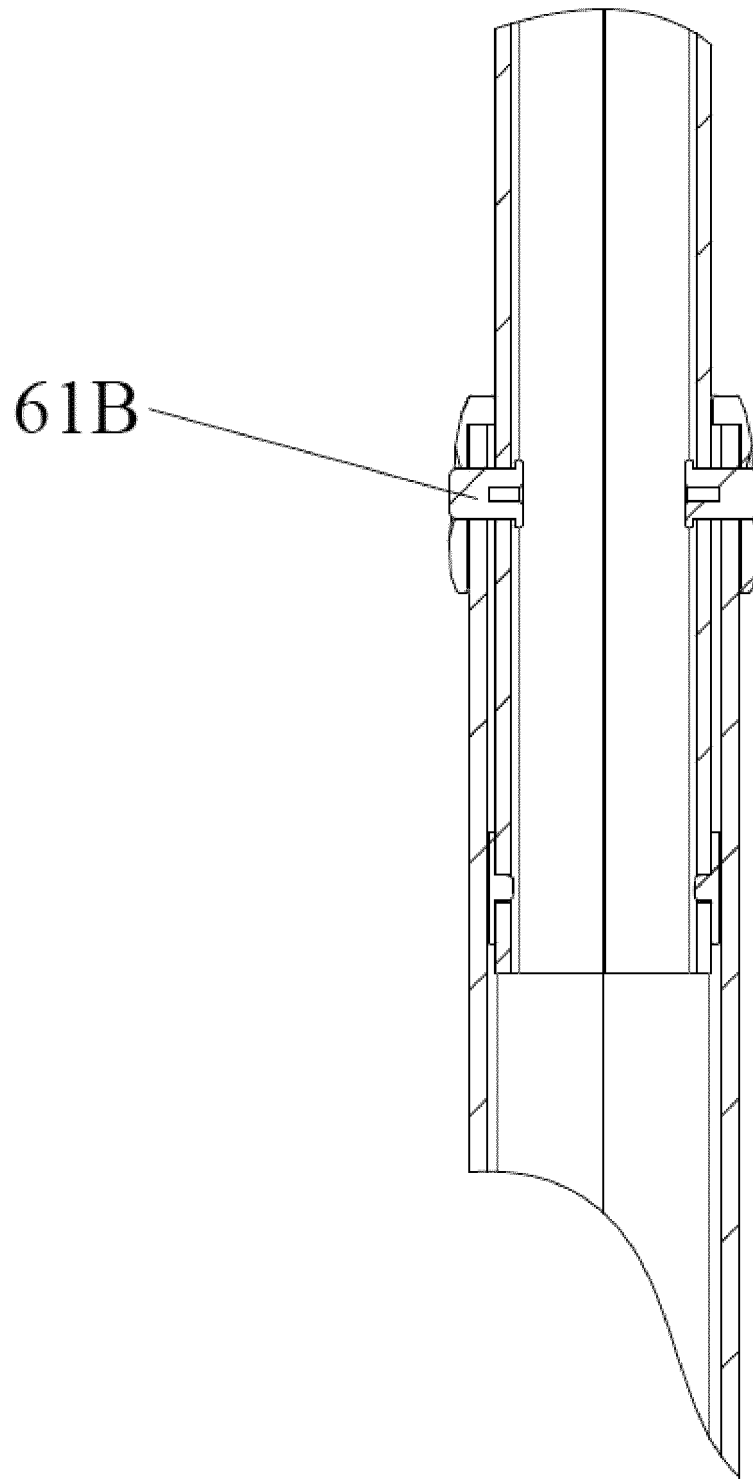

Fig. 16

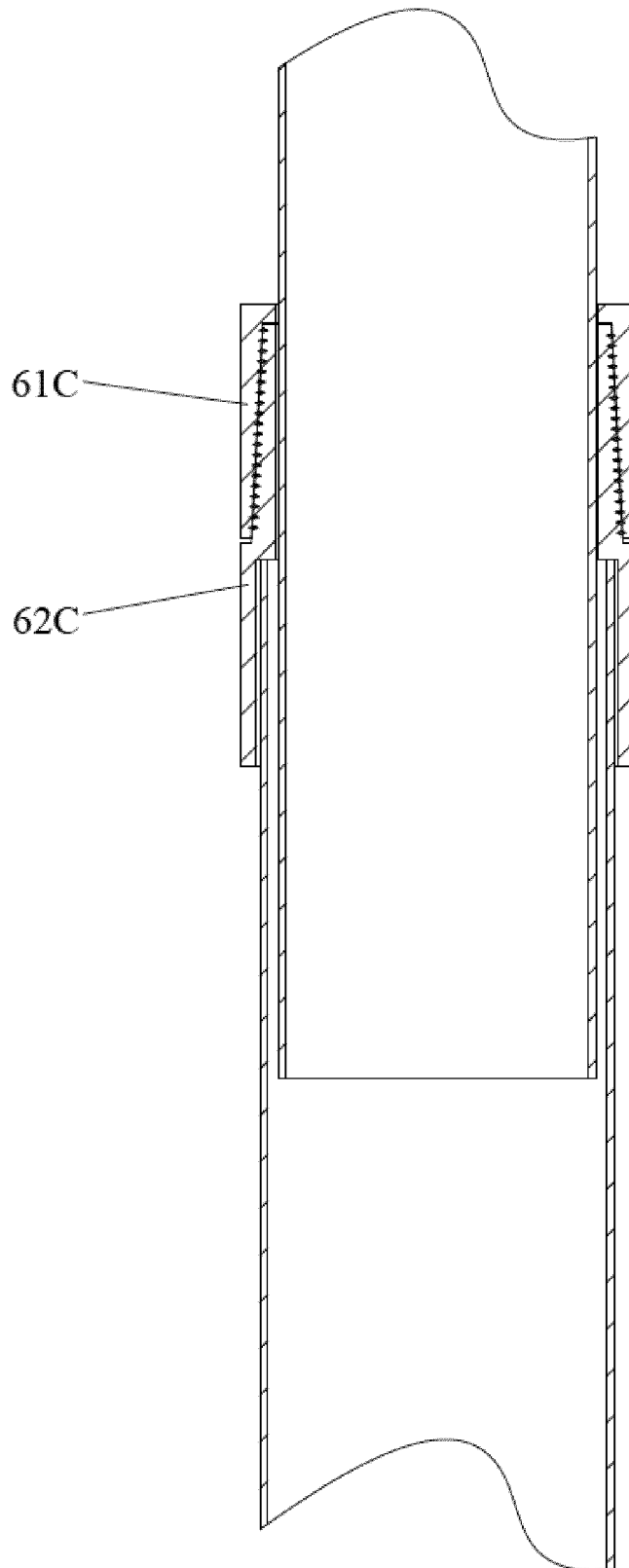

Fig. 17

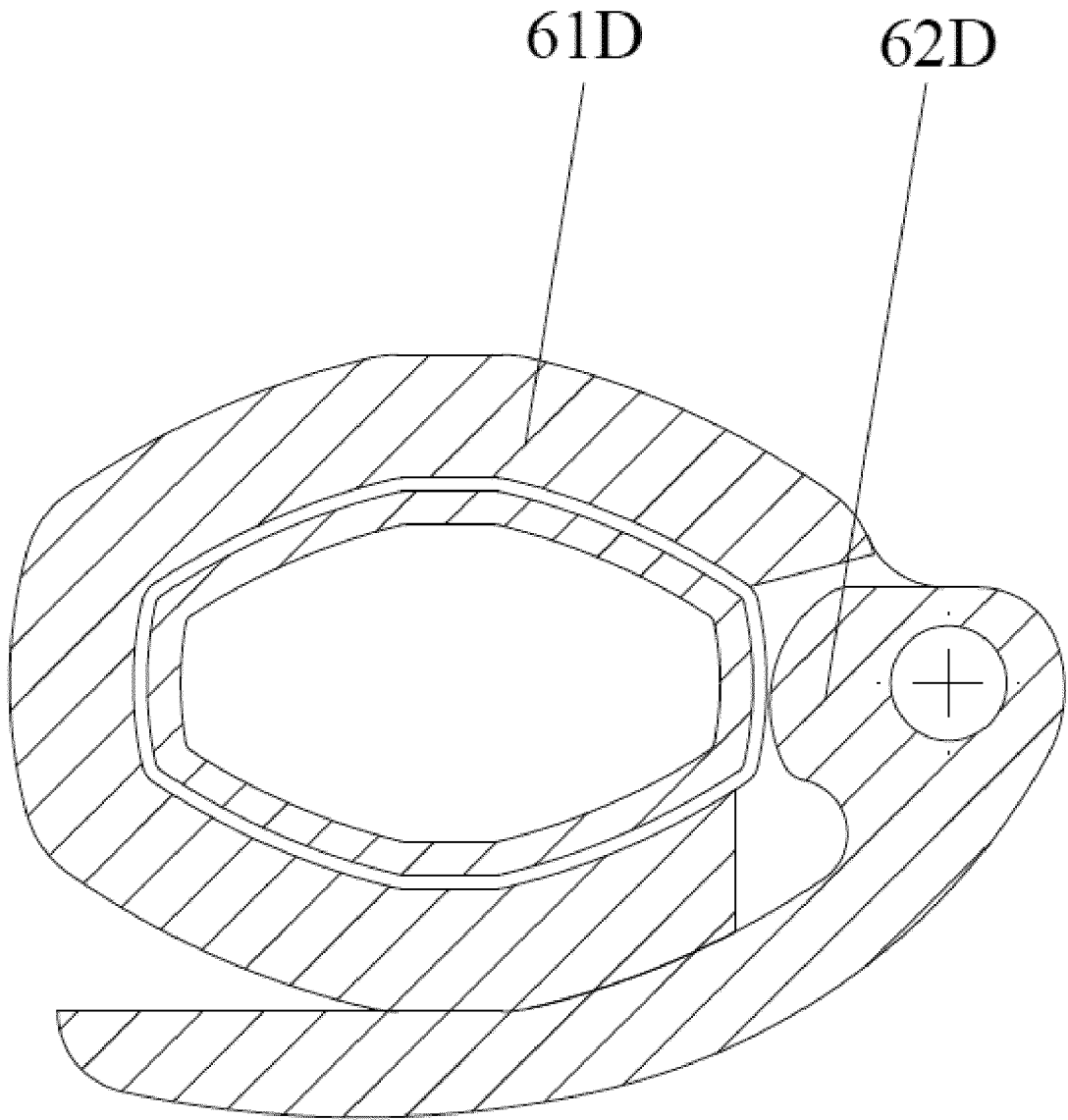

Fig. 18



EUROPEAN SEARCH REPORT

Application Number
EP 21 17 0834

5

10

15

20

25

30

35

40

45

50

55

DOCUMENTS CONSIDERED TO BE RELEVANT			
Category	Citation of document with indication, where appropriate, of relevant passages	Relevant to claim	CLASSIFICATION OF THE APPLICATION (IPC)
X	US 2003/070700 A1 (TUNG TERRY [TW]) 17 April 2003 (2003-04-17) * paragraphs [0041] - [0044]; figures * -----	1,3-5,7, 8,10	INV. A45B19/06
X	EP 2 614 746 A1 (EXPOTRADE GROUP GMBH [AT]) 17 July 2013 (2013-07-17) * paragraphs [0033] - [0055]; figures * -----	1,2,4,5, 7,8,10	
X	US 1 750 379 A (STANLEY AKRIGG) 11 March 1930 (1930-03-11) * page 2; figures * -----	1,3-6,10	
			TECHNICAL FIELDS SEARCHED (IPC)
			A45B
The present search report has been drawn up for all claims			
Place of search The Hague		Date of completion of the search 5 October 2021	Examiner Dinescu, Daniela
CATEGORY OF CITED DOCUMENTS X : particularly relevant if taken alone Y : particularly relevant if combined with another document of the same category A : technological background O : non-written disclosure P : intermediate document		T : theory or principle underlying the invention E : earlier patent document, but published on, or after the filing date D : document cited in the application L : document cited for other reasons & : member of the same patent family, corresponding document	

EPO FORM 1503 03.02 (P04C01)

