



(11) **EP 3 992 128 A1**

(12) **EUROPEAN PATENT APPLICATION**

(43) Date of publication:
04.05.2022 Bulletin 2022/18

(51) International Patent Classification (IPC):
B65H 65/00 (2006.01) B65H 75/28 (2006.01)

(21) Application number: **21206087.5**

(52) Cooperative Patent Classification (CPC):
B65H 65/005; B65H 75/285; B65H 2701/34

(22) Date of filing: **02.11.2021**

(84) Designated Contracting States:
AL AT BE BG CH CY CZ DE DK EE ES FI FR GB GR HR HU IE IS IT LI LT LU LV MC MK MT NL NO PL PT RO RS SE SI SK SM TR

Designated Extension States:
BA ME

Designated Validation States:
KH MA MD TN

(30) Priority: **03.11.2020 IT 202000026170**

(71) Applicant: **Innovo Engineering and Construction LTD**
Aberdeen AB10 1UQ (GB)

(72) Inventors:
• **MALAGODI, Stefano**
25019 Sirmione (BS) (IT)
• **TIBERIO, Andrea**
35020 Albignasego (PD) (IT)

(74) Representative: **Caldon, Giuliano et al**
Gallo & Partners S.r.l.
Via Rezzonico, 6
35131 Padova (IT)

(54) **BENDING APPARATUS FOR FLEXIBLE CABLES WOUND AS A REEL AND A METHOD FOR BENDING THE TERMINAL PORTION OF A FLEXIBLE CABLE WOUND AS A REEL**

(57) Bending apparatus (1) for flexible cables (C) wound as a reel, comprising a support frame (2) placed below a winding drum (102) of an equipment piece (100), and an operative arm (3), which comprises a constrained portion (31) rotatably constrained to the support frame (2) and a thrust portion (32) intended to act in abutment against a terminal portion (C1) of a flexible cable (C) wound as a reel around the winding drum (102).

The bending apparatus (1) also comprises movement means (4), mechanically connected to the operative arm (3) in order to move it between a lowered position and a lifted position, and lifting means (5) comprising at least one lifting device (6), which comprises a reaction member (61), adapted to interact with the floor (P) on which the support frame (2) rests, and an action member (62), which is engaged with the reaction member (61) in a movable manner along a movement direction (X), is connected to the support frame (2), and is movable along the movement direction (X) in order to position the support frame (2) with multiple different work heights (H).

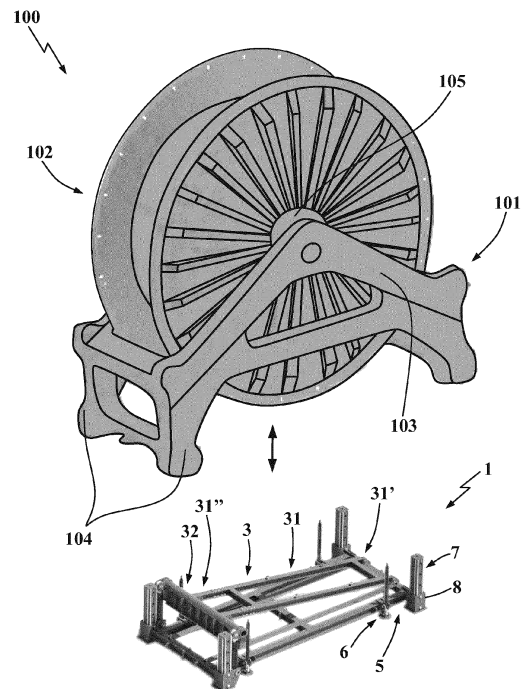

Fig. 1

EP 3 992 128 A1

Description

Field of application

[0001] The present invention regards a bending apparatus for flexible cables wound as a reel and a method for bending the terminal portion of a flexible cable wound as a reel according to the relative independent claims.

[0002] The present bending apparatus and method fall within the industrial field of production of offshore equipment and they are intended for a use in the field of laying cables on beds of seas, lakes, basins, etcetera.

[0003] More in detail, the bending apparatus, object of the present invention, is advantageously intended to be applied to equipment pieces for winding/unwinding flexible cables, such as an energy transmission cable, a signal cable for the data transmission, or deformed steel cables employed for example for injecting compressed air or water in an oil well. For example, such cables have diameter about between 6 and 24 meters and weight approximately between 200 and 2500 tons.

[0004] In particular, the bending apparatus, object of the present invention, is intended to be employed for bending the terminal portion of the cable and bringing it in abutment against the reel, for on-land operations, on offshore platforms and on ships.

State of the art

[0005] Equipment pieces for unwinding cables on seabeds are known in the reference field, which conventionally comprise a support structure formed by a base and by two shoulders which are extended for several meters parallel to each other starting from the base and which support a winding drum therebetween with horizontal axis and diameter of several meters.

[0006] Around this winding drum, a cable to be laid is wound, forming multiple coils side-by-side which form a reel of such cable.

[0007] For example, the operations of winding the cable around the winding drum are executed on land, for example in proximity to a production plant or a storage or distribution base. In such operations, the winding drum is rotatably mounted on a support frame with motorization means mounted thereon in order to rotate the winding drum itself.

[0008] In operation, in order to wind the cable on the winding drum, the latter is connected to one end of the cable and subsequently is rotated by the motor means, coiling the tube around the drum.

[0009] After the winding of the cable, the winding drum is transported at the work site (such as an offshore platform or the deck of a laying ship), possibly together with the support frame which can be employed in order to position the drum in the desired position and can possibly also form part of the unwinding equipment piece.

[0010] In particular, the flexible cables used are typically wound in reels with diameter comprised between

about 6 and 11 meters and weight about 200 and 500 tons, and in particular, in the case of deformed steel cables employed for example for injecting compressed air or water in an oil well so as to control the leveling of the latter, such cables are wound in reels with of about 24 meters and weight of about 2400 tons.

[0011] At the end of the winding operations, the terminal portion of the cable is fixed to the reel by means of suitable chains in order to retain it in position, in particular during the transportation, without such terminal portion being able to oscillate.

[0012] Therefore, a particularly important problem in the field is that of bringing also the free terminal portion thereof in contact with the reel and between the two flanges.

[0013] If this is not provided, such free terminal portion would not be fixed to the latter and therefore would be free to be moved, making the transportation of the reel difficult, possibly causing damage and constituting a danger for the operators in charge of transportation.

[0014] In order to resolve such drawback, the equipment pieces for winding/unwinding cables on the seabeds are provided with bending apparatuses, which are aimed to bend the free terminal portion of the cables once the latter have been wound on the reel.

[0015] Such bending apparatuses are mounted on the support structure of the equipment piece and in particular placed below the reel.

[0016] In addition, such bending apparatuses are provided with a substantially rectilinear operative arm hinged to the center of the support structure of the equipment piece. Generally, the operative arm is made by means of a box-like beam and terminates at its free end with a horizontal thrust bar, which, following the rotation of the operative arm approaching the reel, acts on the free terminal portion of the cable in order to plastically deform it and bend it, bringing it to adhere to the more external coils of the cable reel).

[0017] In addition, such bending apparatuses are provided with movement means, in general a hydraulic piston hinged at the ends respectively to the operative arm and to the support structure and intended to rotate the operative arm by exerting against the cable a force on the order of hundreds of ton-force.

[0018] The document GB 2247898 A describes a further bending apparatus which comprises an operative arm hinged to the base of the support structure of the equipment piece set on the ground by means of multiple wheels. The operative arm is moved by means of a hydraulic cylinder and is provided, at the free end thereof, with an idle wheel intended to come into contact with the free terminal portion of the cable of the reel.

[0019] The above-described bending apparatuses for flexible cables of known type have in practice shown that they do not lack drawbacks.

[0020] The main drawback of these bending apparatuses lies in the fact that they are not always able to sufficiently deform the cable, in particular changing the reel

type. Indeed, the equipment pieces for winding/unwinding the cables are intended to use reels of different diameters, while the operative arm of the bending apparatuses for cables have a fixed length. Therefore, upon varying the diameter of the reels, in particular with smaller reels, the operative arm is not always able to reach the drum and thus completely deform the cable.

[0021] A further drawback of the bending apparatuses of known type lies in the fact that they are generally integrated with the support structure of the equipment piece and, being situated below the reel, render the mounting and removal thereof complex.

[0022] In addition, due to the latter drawback, in case of need such bending apparatuses make it difficult to transport the entire equipment piece, and complicate its maintenance as well. A further drawback of the aforesaid apparatuses of known type is due to the fact that, if the thrust arm acts at one end thereof, it is subject to torsional reactions that could damage the equipment piece or render difficult the action thereof.

Presentation of the invention

[0023] In this situation, the problem underlying the present invention is therefore that of overcoming the drawbacks of the above-described prior art, by providing a bending apparatus for flexible cables wound as a reel and a method for bending the terminal portion of a flexible cable wound as a reel, which allow operating efficiently with reels of different dimensions.

[0024] A further object of the present invention is to provide a bending apparatus for flexible cables wound as a reel, which is adaptable to different equipment pieces for winding/unwinding flexible cables.

[0025] A further object of the present invention is to provide a bending apparatus for flexible cables wound as a reel and a method for bending the terminal portion of a flexible cable wound as a reel, which are entirely safe and entirely reliable in operation.

[0026] A further object of the present invention is to provide a bending apparatus for flexible cables wound as a reel, which is mechanically stable and resistant.

Brief description of the drawings

[0027] The technical characteristics of the invention, according to the aforesaid objects, are clearly found in the content of the below-reported claims and the advantages thereof will be more evident in the following detailed description, made with reference to the enclosed drawings, which represent a merely exemplifying and non-limiting embodiment of the invention, in which:

- figure 1 shows a perspective view of a bending apparatus, object of the present invention, and an equipment piece for winding/unwinding flexible cables, shown separate from each other;
- figure 2 shows a perspective view of the bending

apparatus in figure 1;

- figure 3 shows a top plan view of the present bending apparatus;
- figure 4 shows the detail IV of figure 3;
- 5 - figures 5a and 5b show, respectively, a side view and a front view of the present bending apparatus with lifting devices actuated for abutting against the floor;
- figures 6a and 6b show, respectively, a side view and a front view of the bending apparatus of figure 10 - 10 5a and 5b with blocking elements in non-interference position;
- figures 7a and 7b show, respectively, a side view and a front view of the bending apparatus of figures 15 6a and 6b with the lifting devices actuated for lifting the bending apparatus at a work height;
- figures 8a and 8b show, respectively, a side view and a front view of the bending apparatus of figures 20 7a and 7b with the blocking elements reported in interference position;
- figures 9a and 9b show, respectively, a side view and a front view of the bending apparatus in figures 25 8a and 8b with the lifting devices reported in a retracted position;
- figure 10 shows a side view of the bending apparatus and of the equipment piece for winding/unwinding flexible cables with an operative arm in movement between a lowered position and a lifted position (dashed line) in order to act on the terminal portion 30 of a flexible cable.

Detailed description of a preferred embodiment

[0028] With reference to the enclosed drawings, reference number 1 overall indicates the bending apparatus for flexible cables C wound as a reel, object of the present invention.

[0029] The present bending apparatus 1 is intended to be advantageously employed on-land in plants for producing flexible cables, or in offshore worksites (both on platforms and on ships) in order to wind cables picked up from the bed for example of seas, lakes, water basins.

[0030] In particular, the apparatus 1 is intended to be operatively associated with an equipment piece 100 for winding/unwinding flexible cables C, it too advantageously arranged in the aforesaid flexible cable production plant or in worksites.

[0031] With reference to the enclosed figure 1, the equipment piece 100 is provided with a support structure 101 intended to be abutted against a floor P and with a winding drum 102 rotatably mounted on the support structure 101 with horizontal rotation axis.

[0032] In particular, the support structure 101 comprises two lateral flanks 103, each supported by two corresponding support legs 104 and carrying a hub 105 rotatably mounted thereon.

[0033] Advantageously, the hubs 105 carry the aforesaid winding drum 102 (for example made of steel)

mounted thereon, which advantageously has substantially cylindrical shape and is extended horizontally between two ends, mounted on the hubs 105, in order to bring the corresponding flexible cable C externally wound.

[0034] Of course, without departing from the protective scope of the invention, the equipment piece 100 can be of the type (not illustrated) comprising two vertical towers, two hubs slidably and rotatably associated with the vertical towers and carrying, mounted thereon, the winding drum around which the flexible cable is wound. In addition, the equipment piece 100 can comprise movement means arranged for moving each hub along the corresponding tower, in particular so as to align the hub with the drum in order to engage it with the latter and to lift and lower the drum itself.

[0035] In general, the equipment piece 100 with which the present bending apparatus 1 is intended to be associated can be a (simple) structure (with winding roller 102 and support structure 101) employed (for example in a production or loading plant) for winding the flexible cable C, or it can be an equipment piece (more complex) arranged in the work site with all the systems for laying or collecting the flexible cable C.

[0036] According to the invention, the bending apparatus 1 comprises a support frame 2, intended to be placed below the winding drum 102 of the equipment piece 100, preferably parallel to the floor P.

[0037] In particular, the floor P can be defined by any one support surface, such as the floor of an on-land plant or a deck of a ship or of a platform equipped for operating in an offshore worksite.

[0038] In accordance with the preferred embodiment illustrated in the enclosed figures, the support frame 2 has substantially quadrangular shape with substantially horizontal lying plane.

[0039] Advantageously, the support frame 2 is provided with two lateral beams 22, substantially parallel and side-by-side, extended along a first extension direction Y (substantially horizontal), a head beam 23 and a bottom beam 24, placed to connect between the lateral beams 22. Advantageously, the head beam 23 and bottom beam 24 are substantially parallel and are extended along a second extension direction Z that is transverse, preferably orthogonal, to the first extension direction Y (and substantially horizontal).

[0040] Advantageously, the support frame 2 is provided with at least four connection vertices 21, which are preferably placed to connect between the lateral beams 22 and the head beam 23 or the bottom beam 24.

[0041] In addition, the bending apparatus 1 comprises an operative arm 3, which is mounted on the support frame 2 and comprises a constrained portion 31 and a thrust portion 32.

[0042] In particular, the constrained portion 31 is rotatably constrained to the support frame 2 around a rotation axis R, preferably parallel to the axis of the winding drum 102 (and in particular horizontal). The thrust portion 32

is spaced from the constrained portion 31 and is intended to act in abutment against a terminal portion C1 of a flexible cable C wound as a reel around the winding drum 102 in order to plastically deform the aforesaid terminal portion C1.

[0043] In accordance with the preferred embodiment illustrated in the enclosed figures, in particular in figures 2 and 3, the thrust portion 32 of the operative arm 3 comprises an abutment bar 33, which is extended substantially parallel to the rotation axis R between two opposite ends 33'. In particular, the abutment bar 33 is intended to act in abutment against the flexible cable C in order to deform the terminal portion C1 thereof.

[0044] Advantageously, moreover, the constrained portion 31 of the operative arm 3 between a constrained end 31', which is constrained (e.g. hinged) to the support frame 2 at the rotation axis R, preferably to the bottom beam 24 of the latter, and a fixing end 31", fixed to the thrust portion 32 and in particular to the abutment bar 33.

[0045] In accordance with the particular embodiment illustrated in the enclosed figures, the constrained portion 31 comprises two rotation bars 34, parallel to each other, and each extended between a corresponding constrained end 34', which is constrained to the support frame 2, and a corresponding fixing end 34", fixed to the thrust portion 32.

[0046] According to the invention, the bending apparatus 1 also comprises movement means 4, which are mounted on the support frame 2, are mechanically connected to the operative arm 3 and are actuatable to move the operative arm 3 between at least one lowered position and at least one lifted position.

[0047] In particular, in the lowered position the thrust portion 32 is intended to be spaced from the terminal portion C1 of the flexible cable C. Instead, in the lifted position the thrust portion 32 is adapted to abut against the terminal portion C1 of the flexible cable C in order to curve the terminal portion C1 on the reel, making it adhere on the more external coils of the reel.

[0048] More in detail, in the lowered position the thrust portion 32 of the operative arm 3, and in particular the abutment bar 33, is brought close to the support frame 2 and in the lifted position the thrust portion 32 of the operative arm 3, in particular the abutment bar 33, is more spaced from the support frame 2 at a greater height of the latter in order to engage the flexible cable C, as illustrated in figures 5a, 9a and 10.

[0049] In accordance with the preferred embodiment illustrated in the enclosed figures, the movement means 4 are provided with at least two actuation devices 40 each constrained to the abutment bar 33, preferably at the corresponding end 33'.

[0050] Advantageously, at least one actuation device 40, preferably both, comprises a movement piston 40' extended between a first end 41 hinged to the support frame 2, preferably to the head beam 23 of the latter, and a second end 42 hinged to the operative arm 3.

[0051] In this manner, the movement of the operative

arm 3 between the lifted position and the lowered position is advantageously more stable, even when the terminal portion C1 of the flexible cable C is not placed centered along the thrust portion 32 of the operative arm 3. In addition, in this manner, the division of the loads on the support frame 2 advantageously improves.

[0052] According to the idea underlying the present invention, the bending apparatus 1 comprises lifting means 5 mechanically connected to the support frame 2 and comprising at least one lifting device 6.

[0053] In addition, the lifting device 6 comprises at least one reaction member 61, adapted to interact with the floor P, and at least one action member 62, which is engaged with the reaction member 61 in a movable manner along a movement direction X having at least one vertical component (and preferably substantially vertical), is connected to the support frame 2, and is movable along the movement direction X in order to position the support frame 2 with multiple different work heights H.

[0054] Advantageously, the lifting device 6 comprises at least one linear actuator 60 having the first action member 62 slidably constrained to the reaction member 61 according to the movement direction X. Preferably, the movement direction X is substantially vertical and preferably orthogonal to the first extension direction Y and to the second extension direction Z.

[0055] According to the preferred embodiment illustrated in the enclosed figures, the linear actuator 60 comprises a hydraulic cylinder 60'.

[0056] Preferably, the lifting means 5 comprise at least two lifting devices 6, each applied to a corresponding opposite lateral beam 22 (or to the head beam 23 and bottom beam 24).

[0057] As illustrated in figures 1 and 2, the lifting means 5 advantageously comprise four lifting devices 6, in particular four linear actuators 60, each for example constituted by a hydraulic cylinder 60'. In particular, the lifting devices 6 are mounted two-by-two on the lateral beams 22 of the support frame 2, preferably at the connection vertices 21.

[0058] In accordance with a further embodiment of the invention, not illustrated, the lifting devices 6 are mounted on the head or bottom beams 23, 24.

[0059] Of course, without departing from the protective scope of the invention, the lifting devices 6 can be mounted on any other part of the support frame 2. In addition, the lifting device 6 can comprise any kind of actuator, such as for example of pinion or rack or chain type, or pulley type.

[0060] By means of the lifting devices 6, the support frame 2 can be advantageously lifted and lowered, as illustrated in figures 5-9, hence bringing the operative arm 3 close to or away from the winding drum 102, allowing the bending apparatus 1 to be adapted to the dimensions of the winding drum 102, or to the height from the floor P at which it is placed, or to the fill level of the winding drum 102 (i.e. to the number of coils of flexible cable C wound as a reel).

[0061] According to the preferred embodiment illustrated in particular in figures 1-4, the lifting means 5 also comprise at least one support guide 7 extended according to the movement direction X and intended to be abutted against the floor P, and a connection sliding block 8 slidably constrained to the support guide 7 and connected to the support frame 2.

[0062] More in detail, the support guide 7 comprises at least one support column 70 provided with a base portion 71 intended to be abutted against the floor P, and the connection sliding block 8 is provided with at least one through opening 81 traversed by the support column 70.

[0063] In order to maintain the support guide 7 and the connection sliding block 8 at a pre-established work height H, the lifting means 5 advantageously comprise a plurality of anchorage elements 9 placed on the support guide 7 and positioned along the movement direction X at corresponding work heights H. In addition, the lifting means 5 comprise at least one blocking element 9' constrained to the connection sliding block 8 and actuatable to be moved between an interference position and a non-interference position.

[0064] More in detail, in the interference position, the aforesaid blocking element 9' intercepts one of the anchorage elements 9, rigidly constraining the connection sliding block 8 to the support guide 7 at the corresponding work height H, and in the non-interference position the blocking element 9' is released from the anchorage elements 9, freeing the connection sliding block 8 from the support guide 7 with respect to displacements along the movement direction X.

[0065] In accordance with the preferred embodiment illustrated in the enclosed figures, the anchorage elements 9 are provided with corresponding first engagement holes 91 made in said support guide 7, in particular on the support column 70, and the blocking element 9' comprises at least one coupling pin 90' movable, transverse to the movement direction X, between the interference position and the non-interference position. In particular, in the interference position the coupling pin 90' is, at least partially, inserted in one of the first engagement holes 91, and in the non-interference position the coupling pin 90' is placed outside the first engagement holes 91.

[0066] Advantageously, in addition, the connection sliding block 8 is provided with at least one second engagement hole 92 which, with the support frame 2 at one of the work heights H, is aligned with the first engagement hole 91 of the corresponding anchorage element 9, and in which the coupling pin 90' is inserted at least in the interference position.

[0067] As illustrated in the enclosed figures and as indicated above, the support frame 2 advantageously has substantially quadrangular shape with at least four connection vertices 21. In addition, the lifting means 5 advantageously comprise at least four sliding blocks 8, fixed to the support frame 2 at the corresponding connection

vertices 21, and four support guides 7, in particular each comprising an aforesaid support column 70, with which the corresponding sliding blocks 8 are slidably constrained.

[0068] Advantageously, the first engagement holes 91, and preferably also the second engagement holes 92, are aligned along the second extension direction Z.

[0069] In addition, the blocking elements 9' are advantageously slidably mounted at the ends of the head beam 23 and of the bottom beam 24 and slidable along the second extension direction Z.

[0070] Of course, without departing from the protective scope of the present invention, the first and the second engagement holes 91, 92 can be aligned along the first extension direction Y and the blocking elements 9' can be mounted in an equivalent manner on the lateral beams 22 and slidable along the same first extension direction Y.

[0071] In operation, once the bending apparatus 1 has been brought to the desired work height H, the support guide 7 (in particular the support legs 70) is advantageously brought into abutment against the floor P and the support frame 2 is blocked at the work height H, constraining the blocking element 9' to the corresponding anchorage element 9 at the aforesaid work height H.

[0072] In this manner, it is possible to provide for one or more lifting devices 6 arranged for generating a lifting force sufficient for lifting the support frame 2 to the work height H, i.e. to support the weight thereof, while the reaction member 61 of such lifting device 6 can be picked up from the floor P after the support guide 7 has been blocked at the work height H by means of the anchorage element 9 and the blocking element 9'.

[0073] Therefore, the force generated by the movement means 4, by actuating the operative arm 3 to act on the terminal portion C1 of the flexible cable C, is absorbed and discharged to the floor P by each support guide 7 (in particular by each support column 70), without affecting the lifting devices 60 (and therefore without subjecting them to stresses that could damage them).

[0074] Also constituting the object of the present invention is a method for bending the terminal portion C1 of a flexible cable C wound as a reel, such method being actuated by means of the use of a bending apparatus 1 of the above-described type.

[0075] Hereinbelow, for the sake of description simplicity, reference will be made to the same nomenclature introduced up to now, even if it must be intended that the present method can be obtained also with apparatuses not provided with all the above-considered characteristics.

[0076] The present method provides for a step of arranging the bending apparatus 1 below the winding drum 102 of the equipment piece 100 for winding/unwinding flexible cables C. In such arranging step, the operative arm 3 of the bending apparatus 1 is in the lowered position in order to not interfere with the winding drum 102 or other parts of the equipment piece 100.

[0077] More in detail, in the arranging step the bending

apparatus 1 is carried by means of sliding along the floor P below the winding drum 102 of the equipment piece 100, for example into an empty space between the support legs 104.

[0078] Advantageously, in the arranging step the lifting means 5 are placed away from the floor P, in particular with the reaction member 61 of the lifting device 6 in a retracted position, in which the reaction member 61 is placed close to the support frame 2.

[0079] In the arranging step the support guide 7 is advantageously placed in abutment against the floor P, preferably by means of the base portion 71 of the support column 70.

[0080] Preferably, in the arranging step, the blocking elements 9' are placed in the interference position, i.e. they are engaged with the anchorage elements 9 in order to maintain the support guide 7 and the support frame 2 constrained.

[0081] According to the invention, after the aforesaid arranging step, the method also provides for a deformation step, in which the movement means 4 are actuated to move the operative arm 3 from the lowered position to the lifted position.

[0082] More in detail, in the deformation step, the thrust portion 32 of the operative arm 3 in the lifted position abuts against the terminal portion C1 of the flexible cable C wound as a reel around the winding drum 102 and bends such terminal portion C1 in order to curve it on the reel (making it substantially adhere to the more external coils of the reel).

[0083] Advantageously, in the deformation step the movement means 4, and in particular the actuation devices 40, exert a force on the thrust portion 32, in particular on the abutment bar 33, equal to or greater than that necessary in order to plastically deform the flexible cable C.

[0084] According to the idea underlying the present invention, the method comprises, between the arranging step and the deformation step, a step of adjusting the work height H, in which the lifting means 5 are actuated to move the support frame 2 along the movement direction X up to a specific work height H. In particular, such work height H is for example defined as a function of the size and/or height of the winding roller 102 or of the number of coils of the reel wound around the latter, thus allowing the operative arm 3, in the subsequent deformation step, to appropriately reach the terminal portion C1 of the flexible cable C.

[0085] More in detail, as illustrated in figures 5a and 5b, initially the adjustment step optionally provides that the reaction members 61 are actuated to slide along the relative action members 62 and brought to abutment against the floor P.

[0086] Subsequently, as illustrated in figures 7a and 7b, the reaction members 61 are advantageously actuated to further slide along the relative action members 62 into at least one extended position, in which they are placed away from the support frame 2, imparting a lifting

force to the floor P that is equal to or greater than the weight of the bending apparatus 1 (at most minus the weight support guides 7 and the lifting devices 6). Consequently, the support frame 2 is subjected to a force such to bring it to the work height H. Once such desired work height H is reached, the lifting device 6 is stopped.

[0087] Advantageously, before actuating the lifting devices 6 in order to lift the support frame 2, the blocking element 9' is brought from the interference position to the non-interference position, as illustrated in figures 6a and 6b, so as to allow the connection sliding block 8 to freely slide along the support guide 7.

[0088] Therefore, the adjustment step provides for, simultaneous with the actuation of the lifting device 6, the relative sliding between the support guide 7 and the connection sliding block 8.

[0089] In accordance with the preferred embodiment of the invention, the adjustment step of the method then provides for, with the reaction member 61 in abutment against the floor P and with the blocking element 9' in the non-interference position, actuating the lifting device 6 up to bringing the support frame 2 to the predetermined work height H with the connection sliding block 8 aligned with the corresponding anchorage element 9 at the predetermined work height H.

[0090] As illustrated in figures 8a and 8b, the adjustment step also advantageously provides for moving (once again) the blocking element 9' from the non-interference position to the interference position, in which the blocking element 9' intercepts the anchorage element 9, rigidly constraining the connection sliding block 8 to the support guide 7 in the corresponding said work height H.

[0091] In addition, as illustrated in figures 9a and 9b, after the blocking element 9' has been placed (or newly placed) in the interference position, the reaction member 61 of the lifting device 6 is lifted from the floor P. In this manner, the lifting device 6 is not subjected to strong loads/stresses during the subsequent deformation step.

[0092] In particular, in the aforesaid figures the movement of the reaction members 61 is indicated with the arrows directed from/towards the floor P, while the movement of the blocking elements 9' is indicated with the arrows directed from/towards the support guides 7.

[0093] The invention thus conceived therefore achieves the pre-established objects.

Claims

1. Bending apparatus (1) for flexible cables (C) wound as a reel, said bending apparatus (1) being intended to be operatively associated with an equipment piece (100) for winding/unwinding flexible cables (C) provided with a support structure (101) intended to be abutted against a floor (P) and with a winding drum (102) rotatably mounted on the support structure (101);

said bending apparatus (1) comprising:

- a support frame (2), intended to be placed below the winding drum (102) of the equipment piece (100);
- an operative arm (3), which is mounted on said support frame (2) and comprises:

- a constrained portion (31) rotatably constrained to said support frame (2) around a rotation axis (R);
- a thrust portion (32) spaced from said constrained portion (31) and intended to act in abutment against a terminal portion (C1) of a flexible cable (C) wound as a reel around the winding drum (102) in order to plastically deform the terminal portion (C1);

- movement means (4), which are mounted on said support frame (2), are mechanically connected to said operative arm (3) and are actuatable to move said operative arm (3) between at least one lowered position, in which said thrust portion (32) is intended to be spaced from the terminal portion (C1) of the flexible cable (C), and a lifted position, in which said thrust portion (32) is adapted to abut against the terminal portion (C1) of the flexible cable (C) in order to curve the terminal portion (C1) on the reel;

said bending apparatus (1) being **characterized in that** it comprises lifting means (5) mechanically connected to said support frame (2) and comprising at least one lifting device (6), which comprises:

- at least one reaction member (61), adapted to interact with the floor (P);
- at least one action member (62), which is engaged with the reaction member (61) in a movable manner along a movement direction (X) having at least one vertical component, is connected to said support frame (2), and is movable along said movement direction (X) in order to position said support frame (2) at multiple work heights (H).

2. Bending apparatus (1) according to claim 1, **characterized in that** said lifting device (6) comprises at least one linear actuator (60) having said first action member (62) slidably constrained to said reaction member (61) according to said movement direction (X).

3. Bending apparatus (1) according to claim 1 or 2, **characterized in that** said lifting means (5) com-

prise:

- at least one support guide (7) extended according to said movement direction (X) and intended to be abutted against the floor (P);
- a connection sliding block (8) slidably constrained to said support guide (7) and connected to said support frame (2).

4. Bending apparatus (1) according to claim 3, **characterized in that** said lifting means (5) also comprise:

- a plurality of anchorage elements (9) placed on said support guide (7) and positioned along said movement direction (X) at corresponding said work heights (H);
- at least one blocking element (9') constrained to said connection sliding block (8) and actuable to be moved between an interference position, in which said blocking element (9') intercepts one of said anchorage elements (9), rigidly constraining said connection sliding block (8) to said support guide (7) in the corresponding said work height (H), and a non-interference position, in which said blocking element (9') is released from said anchorage elements (9), freeing said connection sliding block (8) from said support guide (7) with respect to displacements along said movement direction (X).

5. Bending apparatus (1) according to claim 4, **characterized in that** said anchorage elements (9) are provided with corresponding first engagement holes (91) made in said support guide (7), and said blocking element (9') comprises at least one coupling pin (90') movable, transverse to said movement direction (X), between said interference position, in which said coupling pin (90') is, at least partially, inserted in one of said first engagement holes (91), and said non-interference position, in which said coupling pin (90') is placed outside said first engagement holes (91).

6. Bending apparatus (1) according to claim 4 or 5, **characterized in that** said connection sliding block (8) is provided with at least one second engagement hole (92) which, with said support frame (2) in one of said work heights (H), is aligned with the first engagement hole (91) of the corresponding said anchorage element (9), and in which said coupling pin (90') is inserted at least in said interference position.

7. Bending apparatus (1) according to any one of the preceding claims, **characterized in that** said support guide (7) comprises at least one support column (70) provided with a base portion (71) intended to be abutted against the floor (P), and said connection

sliding block (8) is provided with at least one through opening (81) traversed by said support column (70).

8. Bending apparatus (1) according to any one of the preceding claims from 4 to 7, **characterized in that** said support frame (2) has substantially quadrangular shape with at least four connection vertices (21); wherein said lifting means (5) comprise at least four connection sliding blocks (8) fixed to said support frame (2) at the corresponding said connection vertices (21), and four said support guides (7) with which the corresponding said connection sliding blocks (8) are slidably constrained.

9. Bending apparatus (1) according to any one of the preceding claims, **characterized in that** the thrust portion (32) of said operative arm (3) comprises an abutment bar (33), which is extended substantially parallel to said rotation axis (R) between two opposite ends (33'); wherein said movement means (4) are provided with at least two actuation devices (40) each constrained to said abutment bar (33) at the corresponding said end (33').

10. Method for bending the terminal portion (C1) of a flexible cable (C) wound as a reel, actuated by means of a bending apparatus (1) according to any one of the preceding claims, said method comprising:

- a step of arranging said bending apparatus (1) below a winding drum (102) of an equipment piece (100) for winding/unwinding flexible cables (C), in which said operative arm (3) is in said lowered position;
- a deformation step, in which said movement means (4) are actuated to move said operative arm (3) from said lowered position to said lifted position, in which the thrust portion (32) of said operative arm (3) abuts against a terminal portion (C1) of a flexible cable (C) wound as a reel around said winding drum (102) and bends the terminal portion (C1) in order to curve it on the reel;

said method being **characterized in that** it comprises, between said arranging step and said deformation step, a step of adjusting the work height (H), in which said lifting means (5) are actuated to move said support frame (2) along said movement direction (X) up to a specific work height (H).

11. Method according to claim 10, actuated by means of a bending apparatus (1) according to any one of the claims from 4 to 7, **characterized in that** said adjustment step provides for:

- with said reaction member (61) in abutment against the floor (P) and with said blocking ele-

ment (9') in said non-interference position, actuating said lifting device (6) up to bringing said support frame (2) to said specific work height (H) with said connection sliding block (8) aligned with the anchorage element (9) corresponding to said specific work height (H);

- moving said blocking element (9') from said non-interference position to said interference position, in which said blocking element (9') intercepts said anchorage element (9), rigidly constraining said connection sliding block (8) to said support guide (7) in the corresponding said work height (H).

12. Method according to claim 11, **characterized in that**, after said blocking element (9') has been placed in said interference position, the reaction member (61) of said lifting device (6) is lifted from the floor (P).

5

10

15

20

25

30

35

40

45

50

55

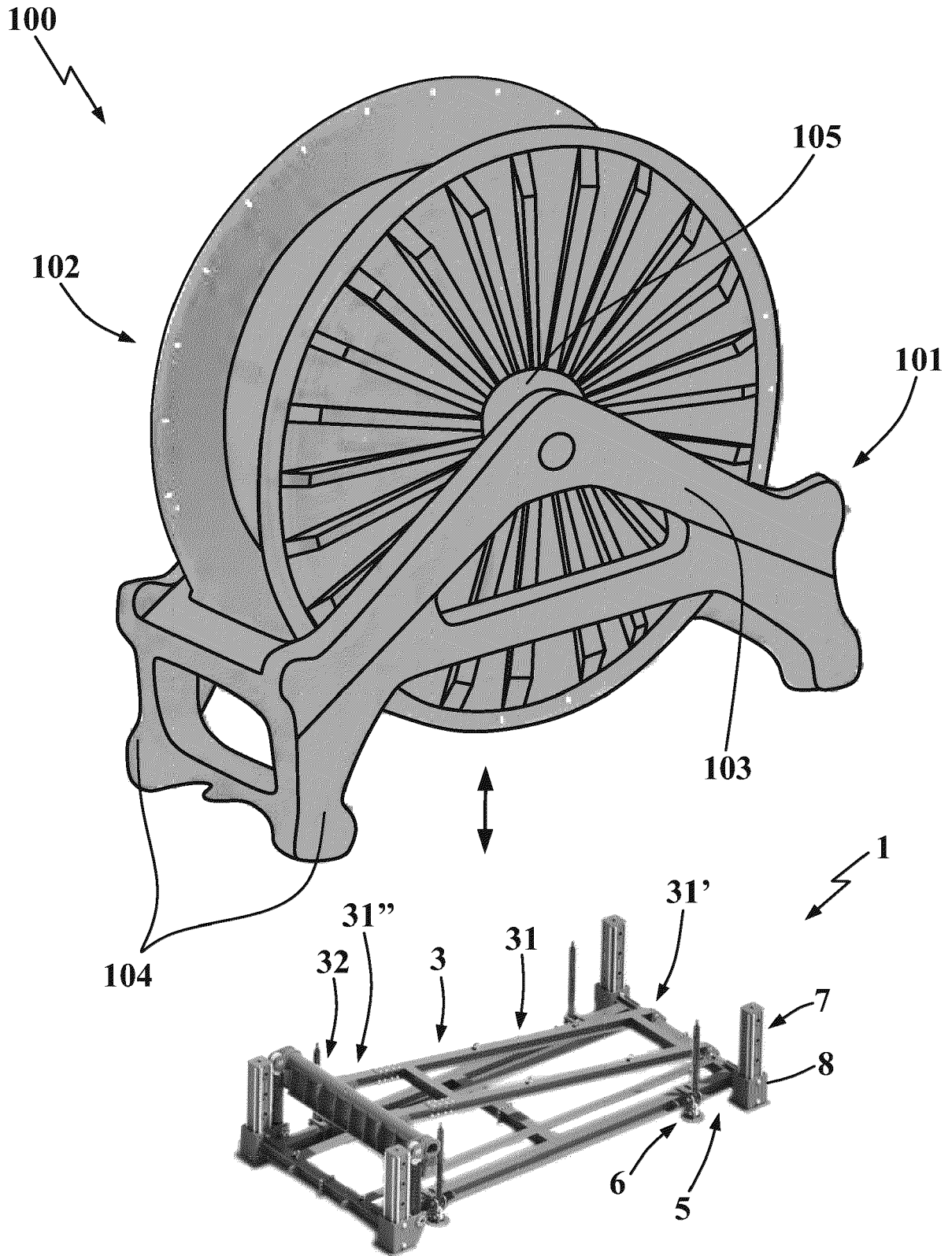

Fig. 1

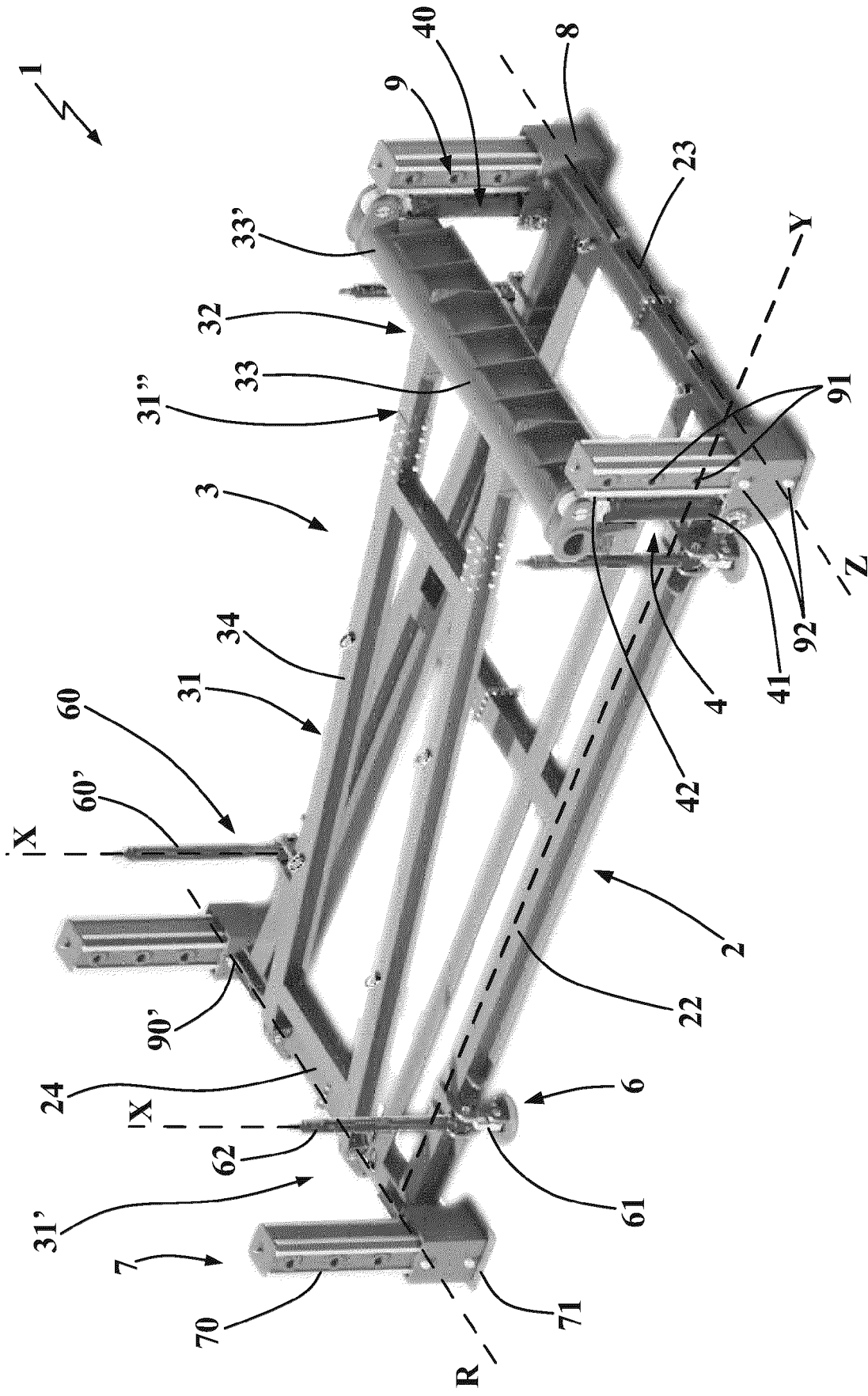

Fig. 2

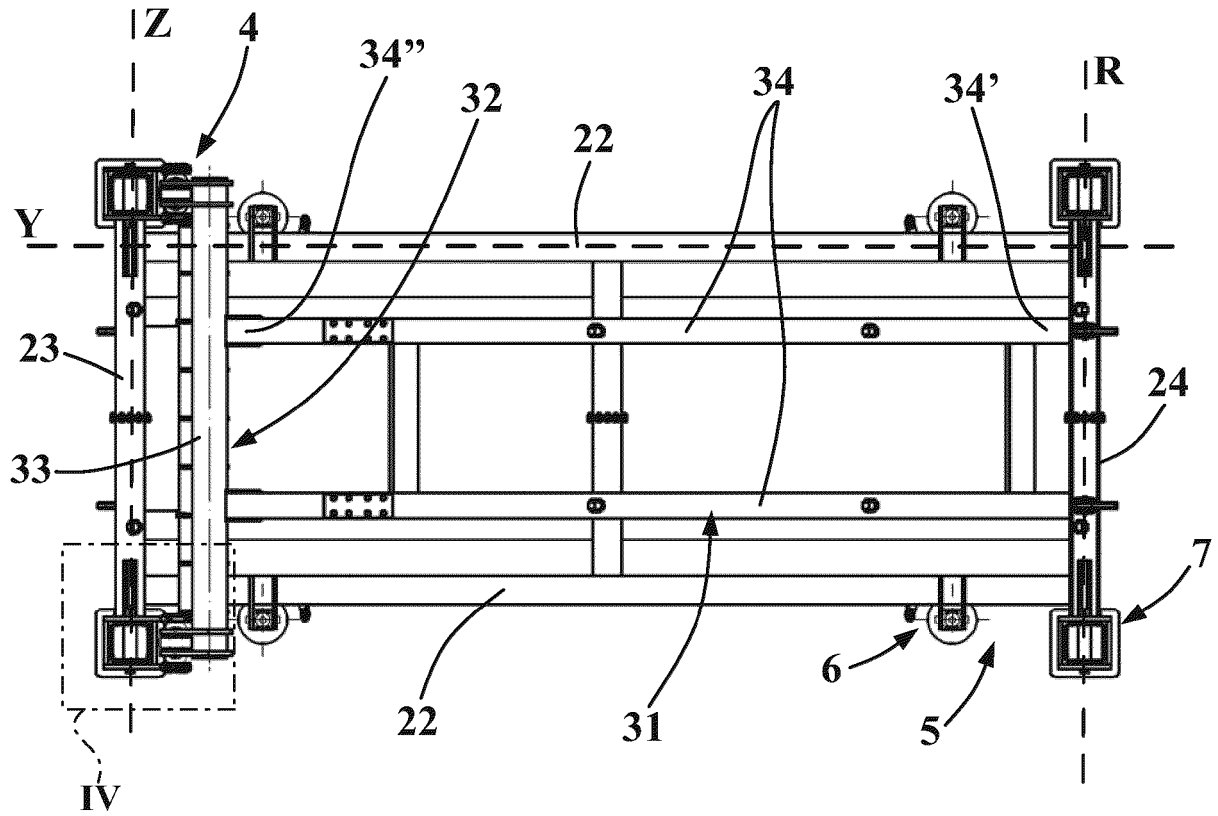

Fig. 3

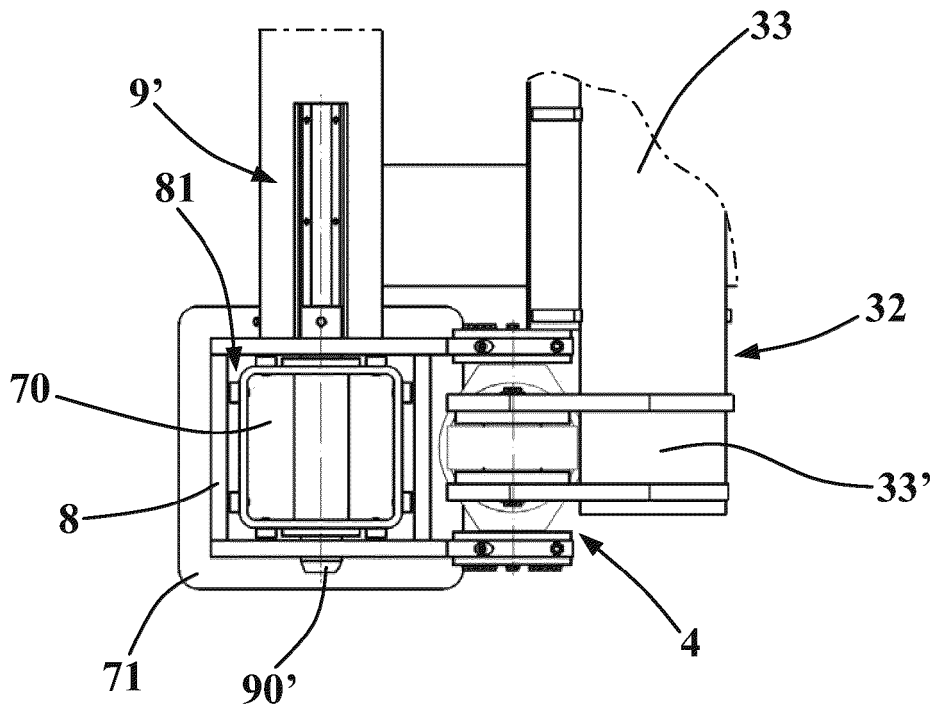

Fig. 4

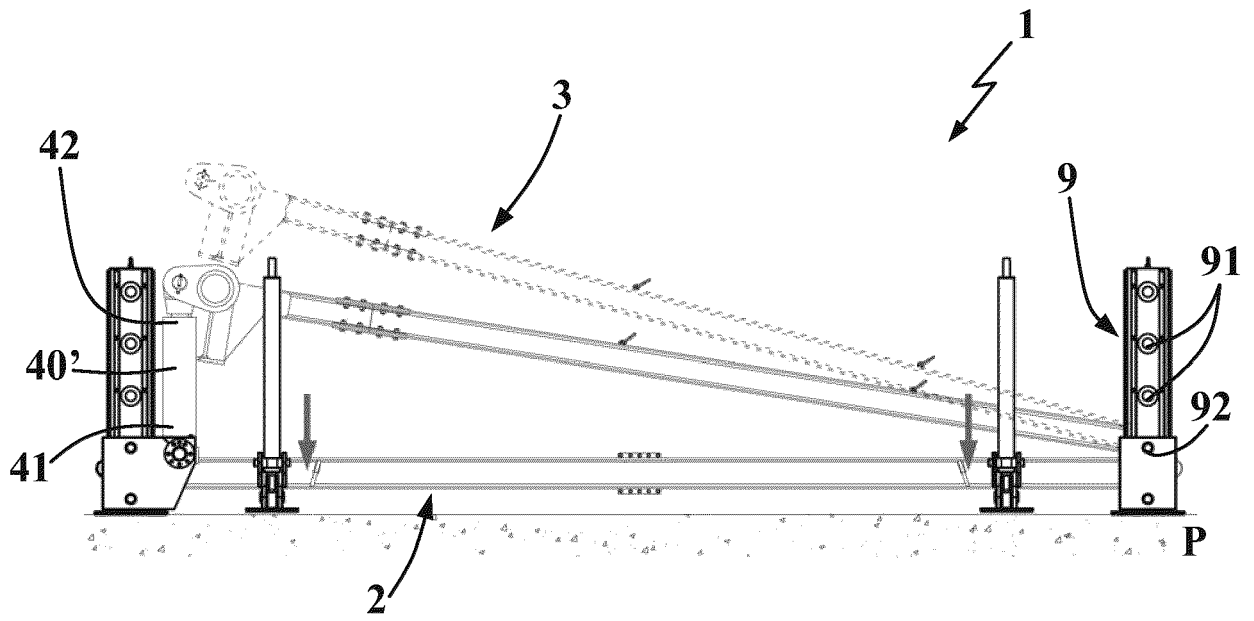

Fig. 5a

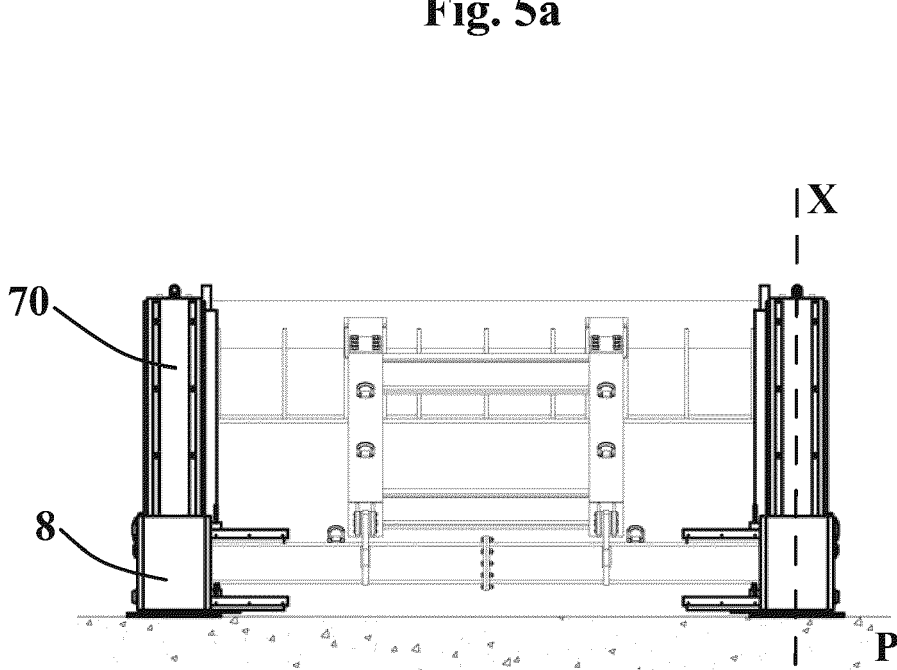

Fig. 5b

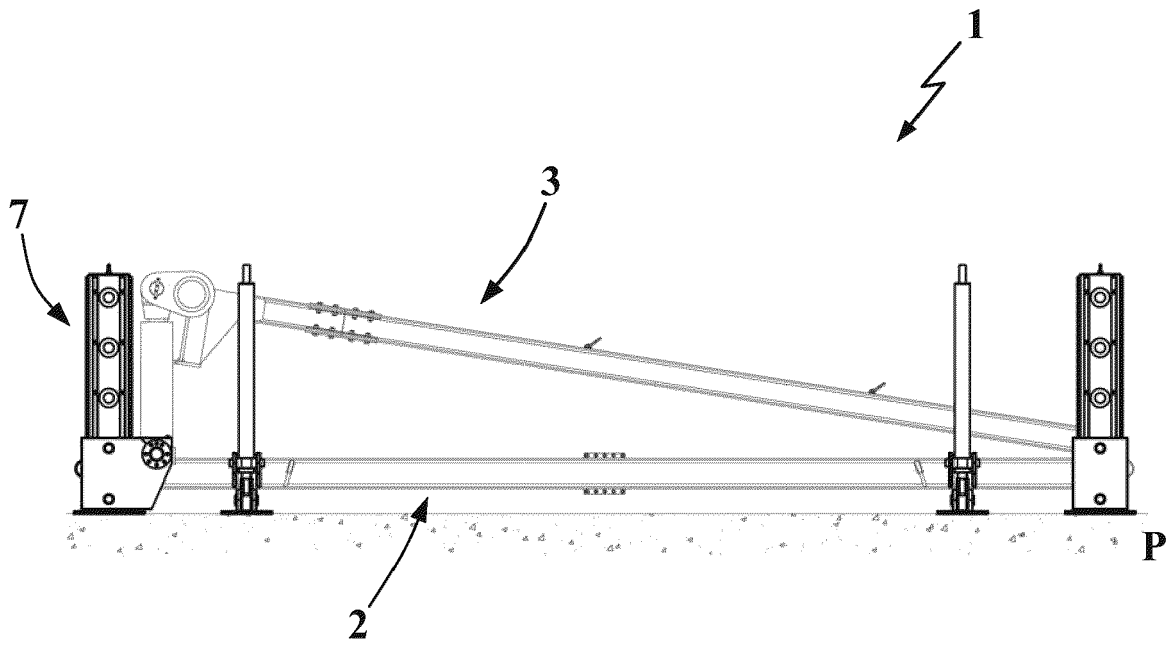

Fig. 6a

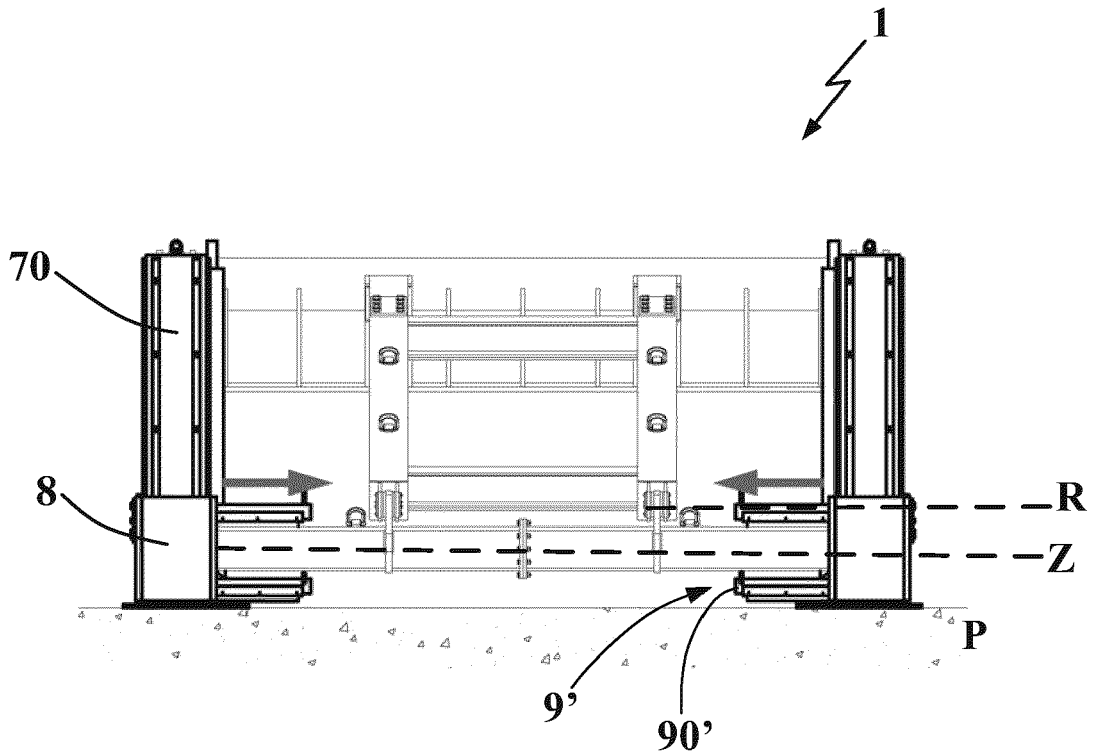

Fig. 6b

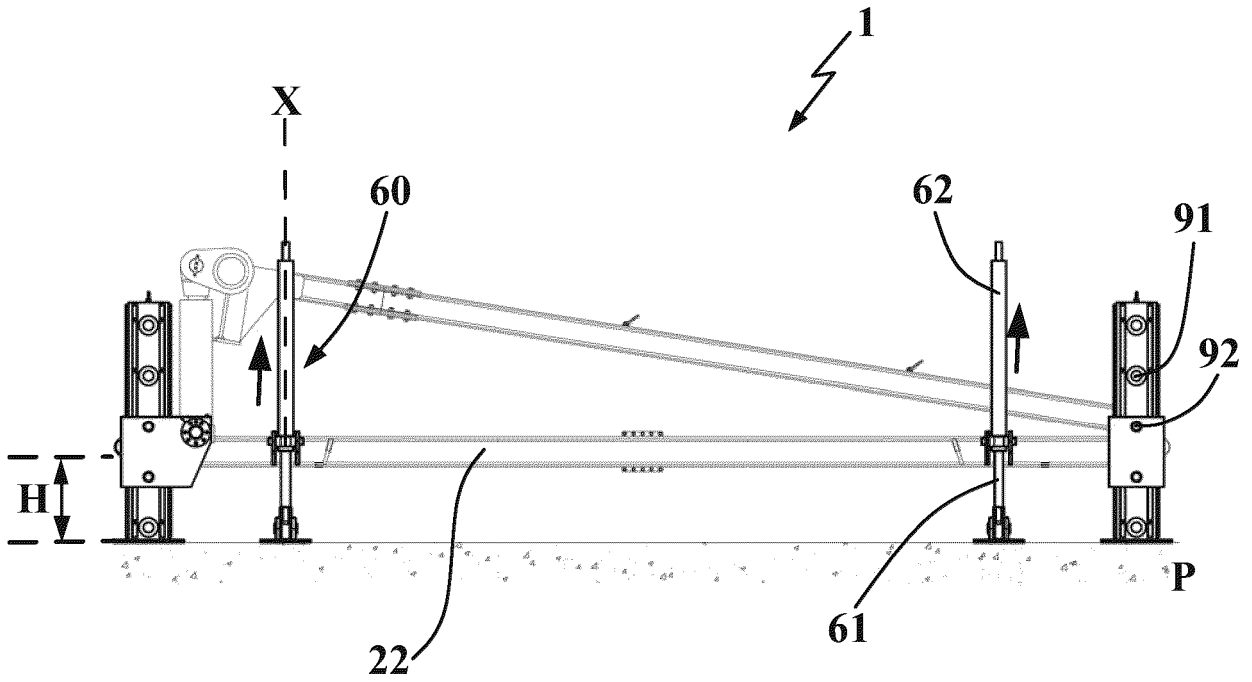

Fig. 7a

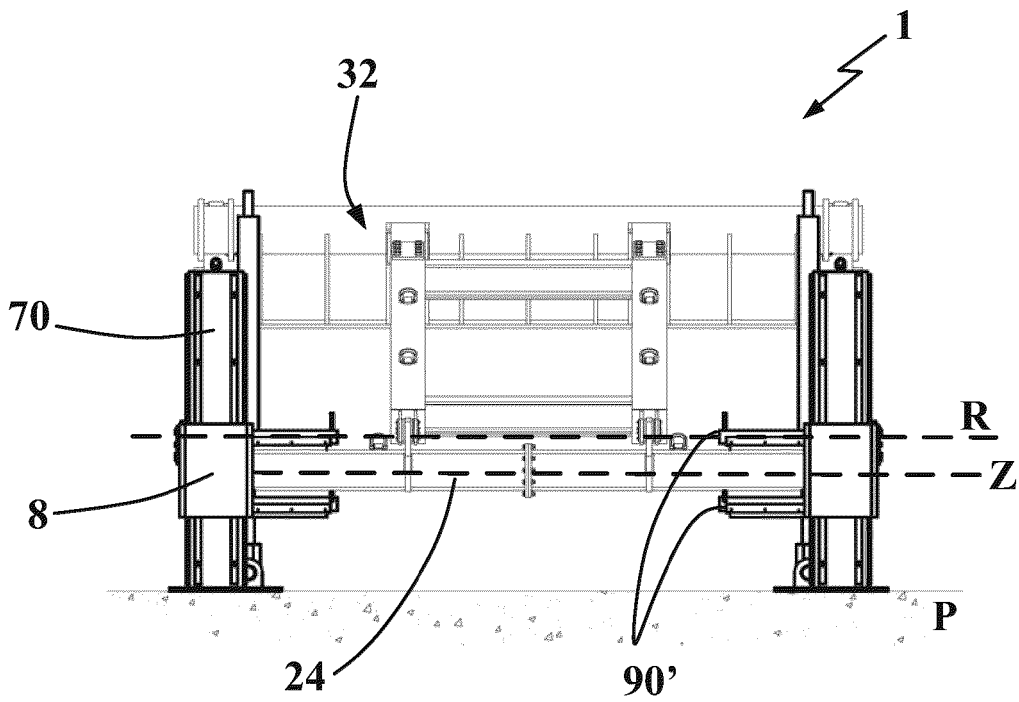

Fig. 7b

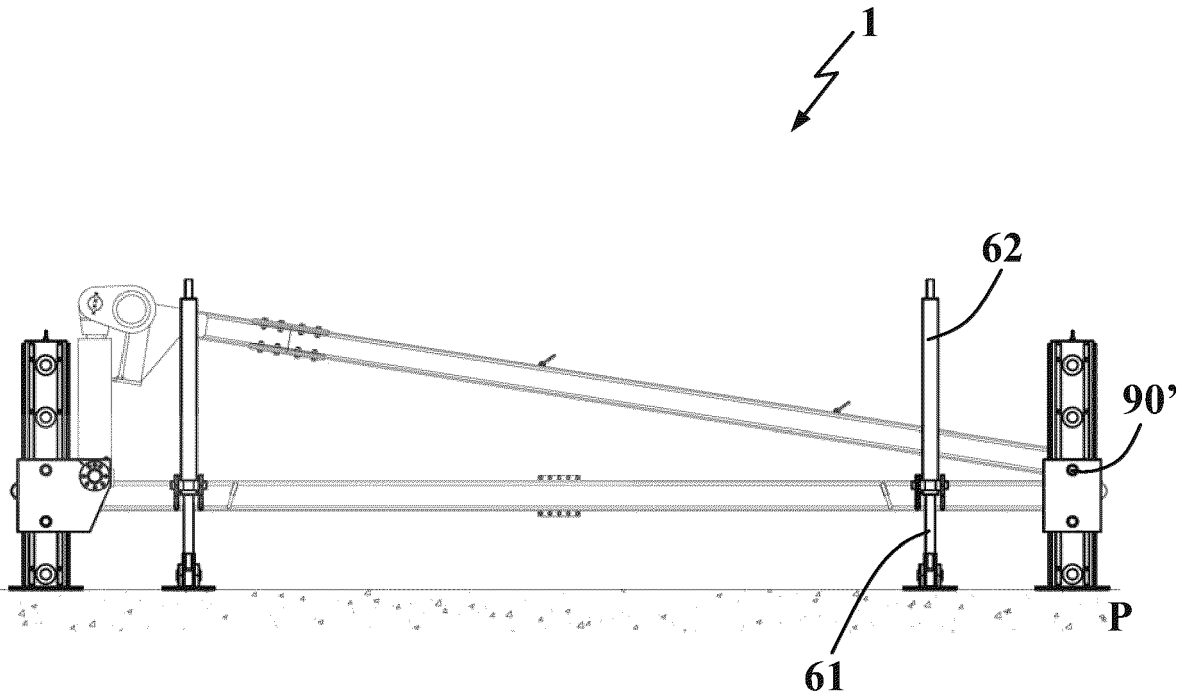

Fig. 8a

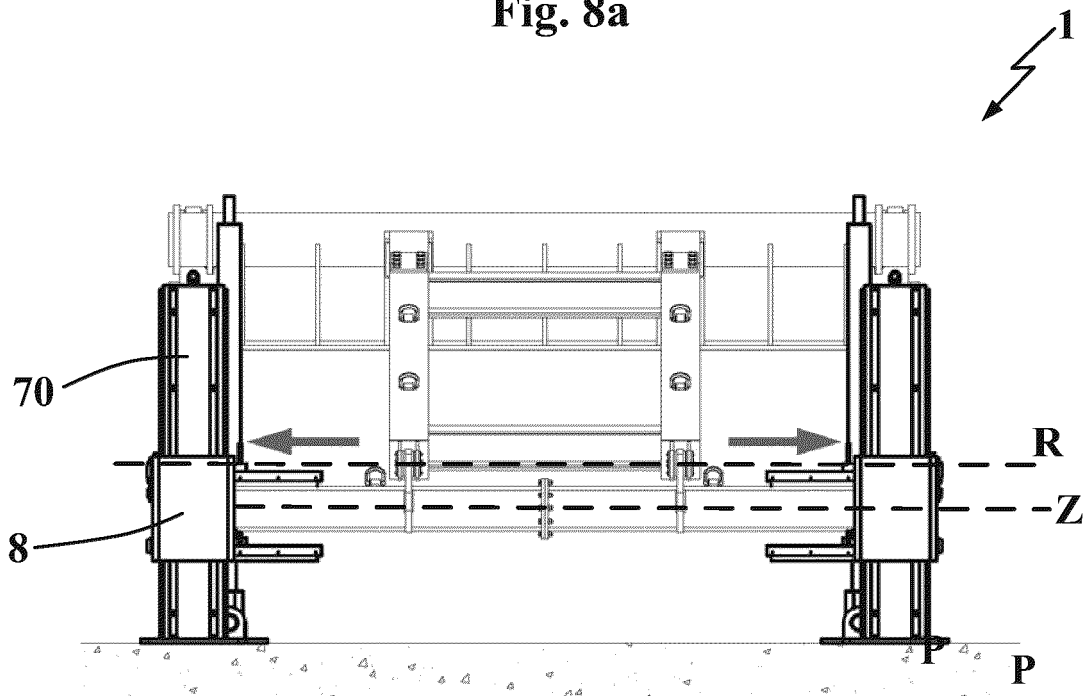

Fig. 8b

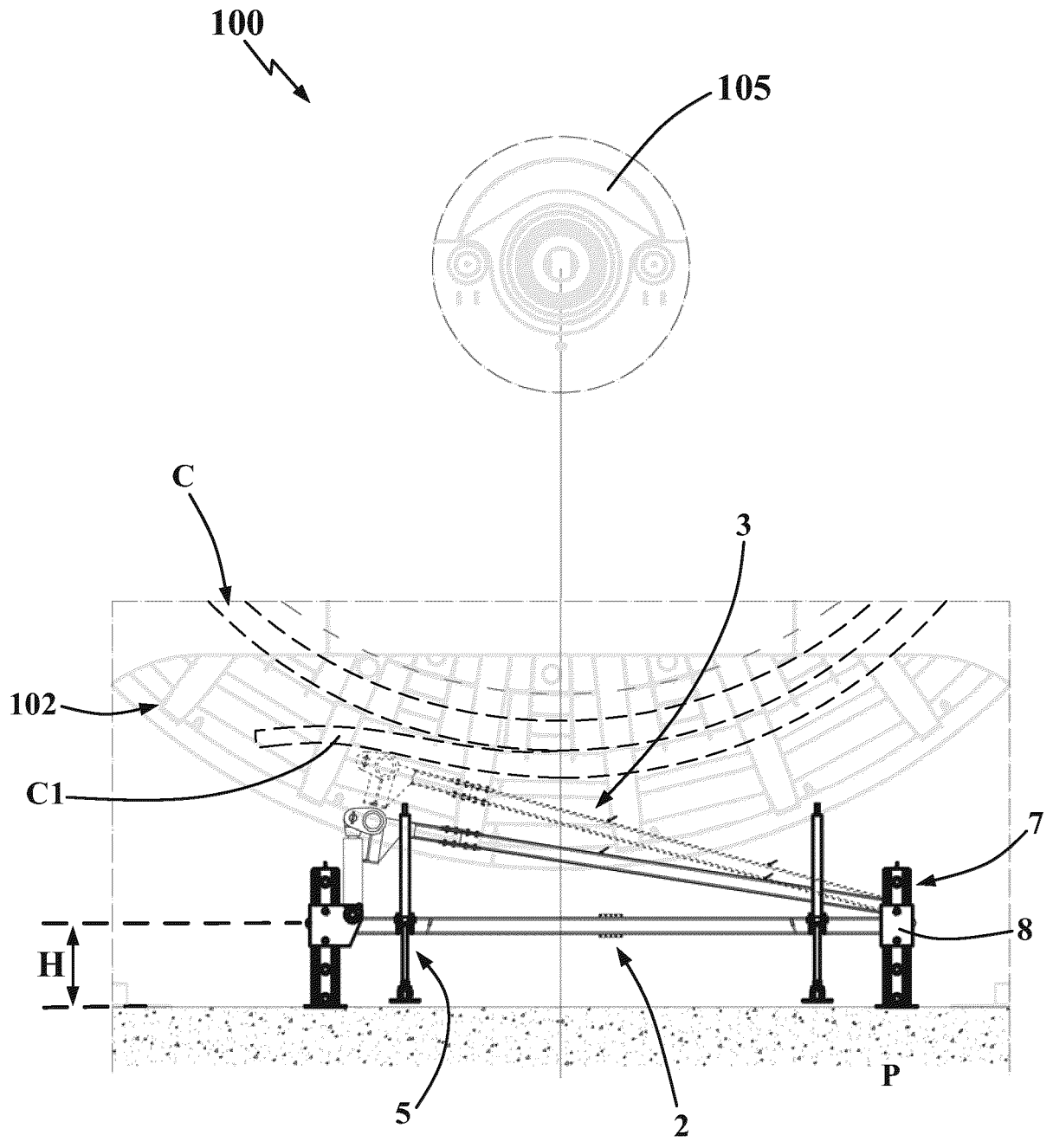

Fig. 10



EUROPEAN SEARCH REPORT

Application Number
EP 21 20 6087

5

10

15

20

25

30

35

40

45

50

55

DOCUMENTS CONSIDERED TO BE RELEVANT			
Category	Citation of document with indication, where appropriate, of relevant passages	Relevant to claim	CLASSIFICATION OF THE APPLICATION (IPC)
A, D	<p>GB 2 247 898 A (REELOTECH LIMITED [GB]) 18 March 1992 (1992-03-18) * page 1, lines 8-11 * * page 2, lines 18-24 * * page 4, line 21 - page 5, line 3 * * page 7, lines 11-27; figures * -----</p>	1-12	<p>INV. B65H65/00 B65H75/28</p>
			<p>TECHNICAL FIELDS SEARCHED (IPC)</p> <p>B65H H02G B63B</p>
1		The present search report has been drawn up for all claims	
Place of search The Hague		Date of completion of the search 19 January 2022	Examiner Lemmen, René
<p>CATEGORY OF CITED DOCUMENTS</p> <p>X : particularly relevant if taken alone Y : particularly relevant if combined with another document of the same category A : technological background O : non-written disclosure P : intermediate document</p>		<p>T : theory or principle underlying the invention E : earlier patent document, but published on, or after the filing date D : document cited in the application L : document cited for other reasons & : member of the same patent family, corresponding document</p>	

EPO FORM 1503 03.82 (P04C01)

**ANNEX TO THE EUROPEAN SEARCH REPORT
ON EUROPEAN PATENT APPLICATION NO.**

EP 21 20 6087

5 This annex lists the patent family members relating to the patent documents cited in the above-mentioned European search report.
The members are as contained in the European Patent Office EDP file on
The European Patent Office is in no way liable for these particulars which are merely given for the purpose of information.

19-01-2022

Patent document cited in search report	Publication date	Patent family member(s)	Publication date
GB 2247898	A	18-03-1992	NONE

EPO FORM P0459

For more details about this annex : see Official Journal of the European Patent Office, No. 12/82

REFERENCES CITED IN THE DESCRIPTION

This list of references cited by the applicant is for the reader's convenience only. It does not form part of the European patent document. Even though great care has been taken in compiling the references, errors or omissions cannot be excluded and the EPO disclaims all liability in this regard.

Patent documents cited in the description

- GB 2247898 A [0018]