



(12) **EUROPEAN PATENT APPLICATION**

(43) Date of publication:
11.05.2022 Bulletin 2022/19

(51) International Patent Classification (IPC):
A47D 13/02 (2006.01)

(21) Application number: **20306323.5**

(52) Cooperative Patent Classification (CPC):
A47D 13/025

(22) Date of filing: **04.11.2020**

(84) Designated Contracting States:
AL AT BE BG CH CY CZ DE DK EE ES FI FR GB GR HR HU IE IS IT LI LT LU LV MC MK MT NL NO PL PT RO RS SE SI SK SM TR
 Designated Extension States:
BA ME
 Designated Validation States:
KH MA MD TN

(71) Applicant: **OVERTEA SA**
6928 Manno (CH)

(72) Inventor: **TSAI, Cecilia**
6928 Manno (CH)

(74) Representative: **Zardi, Marco**
M. Zardi & Co. SA
Via Pioda 6
6900 Lugano (CH)

(54) **CHILD CARRIER**

(57) A child carrier adapted to be worn by a wearer for carrying a child, comprising a hip belt (10) adapted to be secured about the waist of the wearer, and a seat part (30) connected to the hip belt (10). The seat part (30) comprises a seating surface (38) adapted to seat the child on, a main pocket (35) located under the seating surface (38), and an inflatable insert (50) deformable between an inflated state and a deflated state. The inflatable insert (50) provides shape to the seat part (30) when inserted into the main pocket (35) and inflated. The main pocket (35) is reversible and configured to form a storage pocket when turned inside out, the storage pocket being configured to store the seat part (30), including the inflatable insert (50) in its deflated state, and the hip belt (10).

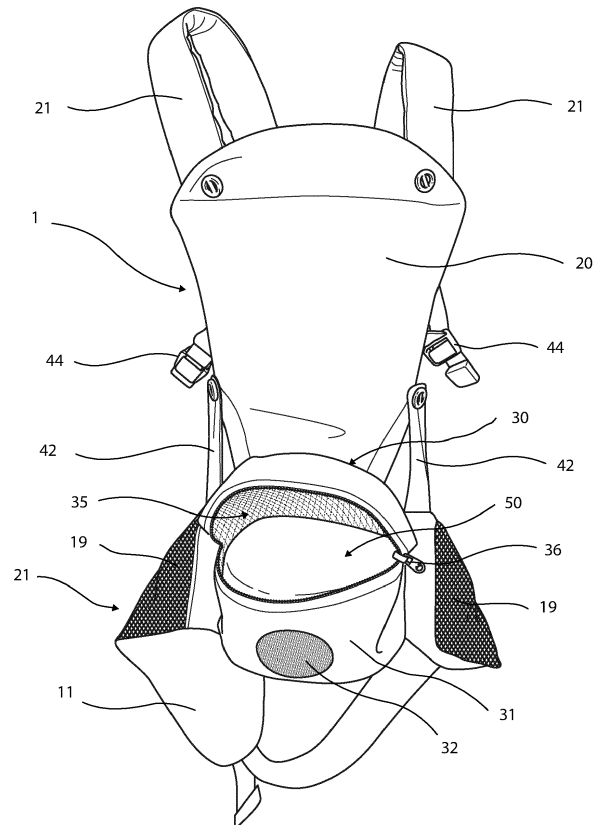

Fig. 1

Description

TECHNICAL FIELD

[0001] The present disclosure relates to child carriers, especially those with a seating surface to seat the child on.

BACKGROUND

[0002] Wearable child carriers allow a wearer (e.g., parent, caretaker) to carry a child (e.g., infant, toddler) comfortably while maintaining freedom of hand and arm movement. Some currently available child carriers wrap around a wearer's waist and provide a seating surface to seat the child thereon. These types of carriers are generally referred to as "hip seats" and are popular on the market. The seating surface is usually half-disc shaped or crescent-shaped, and in the form of a planar shelf, or platform, which extends horizontally when the child carrier is worn. The shape of the seating surface allows child's legs to hang downward. Hip seats may also comprise an upper part extending upwards from the seating surface, for supporting the torso of the child, and shoulder straps for the wearer. Compared to other types of carriers, hip seats have proven to be more convenient and ergonomic for both the child and wearer.

[0003] However, the existing hip seats are not entirely satisfactory. In particular, they are quite bulky and stiff, forming a kind of carapace which may be uncomfortable to wear. This also makes these hip seats difficult to fold and store. Usually, a large storage bag is required for storing and transporting the hip seat. As a result, when not in use, these hip seats are too cumbersome to be stored or transported easily.

[0004] Therefore, while existing hip seats have proven effective, further improvements would be beneficial.

GENERAL PRESENTATION

[0005] To those ends, according to one aspect of the present disclosure, there is provided a child carrier with an inflatable insert and a storage pocket, which can be folded compactly.

[0006] The child carrier is adapted to be worn by a wearer for carrying a child. It comprises a hip belt adapted to be secured about the waist of the wearer, and a seat part connected to the hip belt. The seat part comprises: a seating surface adapted to seat the child thereon, i.e. adapted for supporting the buttocks of the child; a main pocket located under the seating surface; and an inflatable insert deformable between an inflated state and a deflated state. The inflatable insert provides shape to the seat part when inserted into the main pocket and inflated. The main pocket is reversible and configured to form a storage pocket when turned inside out, the storage pocket being configured to store the seat part, including the inflatable insert in its deflated state, and the hip belt.

[0007] It is thus possible to fold the entire child carrier into a compact shape fitting in the storage pocket. Here, "folding" the child carrier may also mean rolling up or balling up the child carrier. In addition, since the storage pocket is obtained by turning the main pocket inside out, there is no need for an additional storage bag. Further, contrary to an additional storage bag, the storage pocket cannot be lost or forgotten by the user.

[0008] In some embodiments, the child carrier further comprises a torso support part for supporting the torso of the child and at least one shoulder strap for the wearer. The torso support part is connected to the seat part. Usually, it extends upwardly from the outer or front edge of the seat part. The torso support part may be detachably connected to the seat part, for instance by a zip fastener. As a variant, the torso support part is non-detachably connected to the seat part, for instance by stitching. The shoulder strap is connected to the torso support part. The child carrier usually comprises two shoulder straps for the wearer.

[0009] In some embodiments, the storage pocket is configured to store the entire child carrier, including the hip belt, the inflatable insert in its deflated state, the torso support part and the shoulder strap(s).

[0010] In some embodiments, the seat part comprises a wearer engagement surface, or inner surface, adapted to rest against the body of the wearer and an outer surface opposite to the wearer engagement surface. Here, "inner" and "outer" are defined with respect to the hip belt center when it is wrapped around the wearer's waist, the inner surface being closer to the center than the outer surface. The main pocket is delimited at the top by the seating surface, on the inner side by the wearer engagement surface and on the outer side by the outer surface. The outer surface may be one same domed surface or be divided into an outer side surface and a bottom surface. In the latter case, the main pocket is delimited at the bottom by the bottom surface, which is opposite to the seating surface.

[0011] In some embodiments, the seat part comprises a pump which is integral with the inflatable insert, the inflatable insert being inflated by operating the pump. Thus, the pump can be stored with the inflatable insert in the storage pocket. Such a pump, contrary to an external pump, cannot be lost or forgotten by the user. The pump may be manually or electrically driven.

[0012] In some embodiments, the pump comprises a movable part to be moved for operating the pump, and the movable part can be manually moved by the wearer through the outer surface of the seat part. The pump can thus be operated and, as a result, the insert can be inflated while the insert is in place inside the main pocket.

[0013] Accordingly, the inflatable insert may be inserted into the main pocket in a partly inflated state. Then the hip belt may be secured about the waist of the wearer and the insert can be gradually inflated by the wearer, up to the desired inflated state. The gradual inflation causes the wearer engagement surface of the seat part

to move against the wearer, which allows the wearer to adjust the tightening of the hip belt around his waist. As a result, the child carrier is best positioned and more comfortable to wear.

[0014] In some embodiments, the outer surface of the seat part has a first textured area having a different texture than a surrounding area of the outer surface and, when the inflatable insert is in place inside the main pocket and inflated or partly inflated, the first textured area is located in front of the movable part and the movable part can be manually moved through the first textured area. The first textured area allows the wearer to find easily, by touch, the movable part. This is helpful because the wearer cannot see the outer surface of the seat part when he is wearing the child carrier.

[0015] In some embodiments, the seat part comprises a deflating valve which is integral with the inflatable insert, the inflatable insert being deflated by operating the deflating valve. The deflating valve may be a normally closed valve which can be manually opened through the outer surface of the seat part. The insert can thus be deflated, at least partly, while it is in place inside the main pocket. This allows the wearer to adjust the tightening of the hip belt around his waist. In addition, the insert can be removed from the main pocket more easily when it is at least partly deflated.

[0016] In some embodiments, the outer surface of the seat part has a second textured area having a different texture than a surrounding area of the outer surface and, when the inflatable insert is in place inside the main pocket and inflated or partly inflated, the second textured area is located in front of the deflating valve and the deflating valve can be manually opened through the second textured area. Like for the first textured area, the second textured area allows the wearer to find easily, by touch, the deflating valve.

[0017] The outer surface of the seat part may have only the first texture area, only the second textured area or both.

[0018] In some embodiments, the child carrier comprises a secondary pocket configured to contain the inflatable insert in its deflated state. Thus, the deflated insert can be stored in the secondary pocket before folding the child carrier and before turning the main pocket inside out. This prevents the user from losing or forgetting the inflatable insert when folding the child carrier. Conversely, when the user unfolds the child carrier by turning inside out the storage pocket, the inflatable insert does not fall out since it is maintained in the secondary pocket.

[0019] In some embodiments, the main pocket has an openable opening located on the outer face of the seat part. The main pocket is turned inside out through this opening and the inflatable insert may be inserted into (or removed from) the main pocket through this opening. The openable opening may be a zip opening.

[0020] The hip belt and most of the elements defining the exterior of the seat part, the torso support part and the shoulder strap(s) may be made of synthetic textile,

such as nylon or polyester. For some elements, a laminate structure may be used. For instance, the shoulder strap may be made of a laminate structure comprising an outer textile layer, an inner textile layer, and an intermediate foam layer may be used.

[0021] The main pocket may be made of a laminate structure comprising an outer textile layer and an inner textile layer having different properties. In particular, the outer textile layer may be less resistant to wear and tear than the inner textile layer. Thus, the outer textile layer which is on the outside when the child carrier is worn, and in contact with the child's legs and wearer's hands and waist, may be made of a soft textile for providing comfort to the child and wearer. Conversely, the inner fabric layer, which is on the outside when the main pocket is turned inside out for storing and transporting the child carrier, may be made of hard-wearing textile.

[0022] Other features and advantages of the child carrier will become apparent from the following detailed description, taken in conjunction with the accompanying drawings, which illustrate the principles of the child carrier. The following detailed description is given by way of example, and not limitation.

25 BRIEF DESCRIPTION OF THE DRAWINGS

[0023] In the drawings, like reference signs typically refer to the same or like parts throughout the different views, unless context dictates otherwise.

[0024] The drawings are for illustrative purpose only and are not necessarily to scale, emphasis instead generally being placed upon illustrating the principles of the invention.

FIG 1 is a front view of an example of a child carrier. The child carrier has a main pocket in which an inflatable insert has been inserted. The main pocket is shown open with the insert inflated.

FIG 2 is a rear view of the child carrier of FIG 1.

FIG 3 is a partial side view of the child carrier of FIG 1 showing the main pocket closed.

FIG 4 shows the inflatable insert in its inflated state.

FIG 5 shows the inflatable insert in its deflated state.

FIGS 6 to 10 illustrate consecutive steps in the folding of the child carrier.

DETAILED DESCRIPTION

[0025] FIGS 1 and 2 are front and rear views of an example of a child carrier 1, respectively. The child carrier 1 comprises a hip belt 10 adapted to be secured about the waist of a wearer (not shown), and a seat part 30 integral with the hip belt 10.

[0026] The seat part 30 comprises a seating surface 38 on which the child is seated. The seating surface 38 may be provided with a non-slip covering. The seat part 30 further comprises a main pocket 35 located under the seating surface 38 and an inflatable insert 50. When in-

serted into the main pocket 35 and inflated, the inflatable insert 50 provides shape and structure to the seat part 30.

[0027] The child carrier 1 further includes a torso support portion 20 for supporting the torso and possibly the head of the child. The torso support portion 20 extends upwardly from the front or outer edge of the seating surface 38. The torso support portion 20 may be detachably or non-detachably connected to the seat part 30, for instance by sewing or by fasteners like snaps, buttons, a zip, patches of hook and loop material or a combination thereof.

[0028] The child carrier 1 further includes first and second shoulder straps 21 for the wearer. Each shoulder strap 21 connects at one end (the first end) to a top area of torso support portion 20. The first end of the shoulder strap 21 may be permanently sewn to the top edge of the torso support portion 20. The other end (the second end) of the shoulder strap 21 may include a webbing which is threaded through an adjuster 44 allowing the shoulder strap 21 length to be adjusted. The adjuster 44 may be connected through another webbing to a side edge of the torso support portion 20. The shoulder straps 21 may comprise an outer surface of durable textile like nylon or polyester and may be padded for additional comfort. The child carrier may further include a chest strap 47 with a buckle 48 that facilitate length adjustment and retain the shoulder straps 21 in an optimal position during child carrier use. The buckle 48 may be a side release buckle. The chest strap 47 may be provided with a protection patch 46 made of soft textile extending under the buckle 48 to protect the chest of the wearer from the buckle 48.

[0029] In use, the hip belt 10 is wrapped around the waist of the wearer and securely attaches the seat part 30 to the wearer. The hip belt 10 includes a first segment 11 attached to one side of the seat part 30, a second segment 12 attached to the other side of the seat part 30 and a buckle 16 between the first and second segments 11, 12. The buckle 16 may be a side release buckle connected to the first and second segments by straps (webbing). One of the straps may be threaded through the buckle 16 and can be length adjusted for adjusting the length of the hip belt 10.

[0030] For structural reinforcement of the child carrier 1, parts of the hip belt 10 that are close to the seat part 30, can be tied to the torso support portion 20 by strips 42 of cloth connected to the sides of the torso support portion 20, for instance by detachable fasteners like buttons or snaps. This may also help to impose an angle between the seating surface 38 and the torso support portion 20.

[0031] The seat part 30 of the child carrier 1 includes a main pocket 35 which can be accessed by an opening 33 closed by a zipper 36. The zipper 36 may be provided with water repellent strips. FIG 1 shows the seat part 30 with the zipper 36 unzipped. FIG 3 is a side view of the seat part 30 with the zipper zipped. The seat part 30 is securely attached (e.g., sewn) to first and second seg-

ments 11, 12 of the hip belt 10. When the carrier 1 is worn, the seating surface 38 forms a substantially horizontal platform on which a child can sit facing the wearer and/or facing outward.

[0032] The main pocket 35 corresponds to an under-seat space which is enclosed or delimited: on the wearer's side, by an inner surface, or wearer engagement surface 34; on the top, by the seating surface 38; on the outside by a side surface 31, and on the bottom, by a bottom surface 37.

[0033] The side surface 31 has an upper part 31A and a lower part 31B. The upper and lower parts 31A, 31B are tied together by the zipper 36. When the zipper 36 is unzipped, the opening 33 is defined between the upper and lower parts 31A, 31B. The inside of the main pocket 35 can be accessed via the opening 33.

[0034] The side surface 31 and the bottom surface 37 form together the outer surface of the seat part 30 within the meaning of the present disclosure.

[0035] When viewed from above, the seating surface 38 is crescent shaped. The outer edge of the seating surface 38 is substantially semi-circular (or semi-elliptical). The outer edge of the bottom surface 37 is also substantially semi-circular (or semi-elliptical), but with a smaller diameter (or major axis). The side surface 31 extends from the outer edge of the seating surface 38 to the outer edge of the bottom surface 37. The side surface 31 is thus curved while being tapered from top to bottom. Such a shape provides a healthy seating posture for the child and reduces the child carrier's profile for better ambulatory maneuverability for the wearer.

[0036] FIGS 4 and 5 show the inflatable insert 50 for the seat part 30, which can be inserted into the main pocket 35, as illustrated in FIG 1. The insert 50 is made of flexible material. The inflatable insert 50 is shown in its inflated state in FIGS 1 and 4, and in its deflated state in FIG 5. Once inserted in the main pocket 35 and inflated, the insert 50 is configured to fully fill or occupy the main pocket 35, thereby providing a sturdy shelf on which the child can sit. As a result, there is no space remaining in the main pocket 35 to store items when the inflated insert 50 is fitted in the main pocket. By contrast, when deflated (FIG. 5), the insert 50 occupies a very limited space and can be stored in the storage pocket 90 while leaving some space to store the whole baby carrier 1, as described below. The insert 50 includes a pump 60 integrated (e.g. by welding) in one side of the insert 50. The pump comprises a movable part 63, in this example a large push-button, which has to be pressed and released repetitively for operating the pump. The deflated insert 50 can thus be inflated manually by repetitive pressing of the movable part 63.

[0037] When the insert 50 is fitted in the main pocket 35, the movable part 63 can be pressed externally through the side surface 31 and the insert 50 can thus be inflated without being removed from the main pocket 35. This makes it possible to inflate (or re-inflate) the insert 50 when wearing the child carrier 1, even with a

child sitting on it, without having to take off the child carrier 1 and without having disturbing the child. The pressing of the movable part 63 through the side surface 31 is facilitated by the presence of a textured area 32 on the side surface 31, i.e. an area of the surface having a different surface geometry, i.e. a different texture, than the surrounding area. For instance, the textured area 32 can be rough, grainy, raised or embossed while the surrounding area is smooth. The pump 60, or at least the movable part 63 thereof, is located just behind the textured area 32. Due to the difference of texture, the textured area 32 and, thus, the movable part 63, can easily be located by touch without having to be seen by the wearer. The movable part 63 being moved by the wearer through the textured area 32, the textured area 32 may be thinner than the surrounding area of the side surface 31, so as to improve the touch sensation of the user. For example, the textured area 32 can be made from mesh fabric.

[0038] Referring to FIG 5, the inflatable insert 50 can be deflated by a deflating mechanism or valve 66 that is located on one side of the insert 50. The valve 66 may be a normally closed valve which can be manually opened through the outer surface of the seat part 30. For instance, the valve can be opened by manually pressing on a button 67 connected to the valve member. When pressure is exerted on the button 67, the valve member moves away from the valve seat and opens the valve 66 so that air can escape from the insert 50. The valve member reverts to its original position after pressure on the button 67 is removed. When the insert 50 is inside the main pocket 35, the button 67 can be pressed externally through the bottom surface 37 and the insert 50 can thus be deflated without being removed from the main pocket 35. Another textured area (not shown) may be provided on the bottom surface 37 of the main pocket 35 and located in front of the valve 66 when the inflated insert 50 is inside the main pocket 35. This allows the user to locate more easily the valve 66 by touch.

[0039] FIGS 6 to 10 illustrate consecutive steps in the folding of the child carrier. As shown in these figures, the main pocket 35 is reversible, meaning that the main pocket 35 can be turned inside out through the opening 33 and thus form a storage pocket 90. The internal surface of the main pocket 35 thus becomes the external surface of the storage pocket 90.

[0040] FIG 6 shows the child carrier with the main pocket 35 open and the insert 50 partly deflated. Before turning inside out the main pocket 35, the deflated insert 50 is removed from the main pocket, completely deflated and stored inside a secondary pocket 19 as illustrated in FIG 7. This makes handling easier when folding the child carrier 1 and prevents the insert 50 from getting lost. In addition, to prevent the insert 50 from getting lost, a tie (not shown in the figures) such as a string or a fabric band, may be provided between the insert 50 and the main pocket 35 (or another part of the baby carrier).

[0041] In this example, the secondary pocket 19 is provided on the outer side of the hip belt 10 and, when the

child carrier 1 is in use, the secondary pocket 19 may be used for holding items like keys, diapers or a bottle. In this example, two secondary pockets 19 are provided on the two segments 11, 12 of the hip belt 10, respectively (see FIG 1), but the secondary pocket(s) could be located elsewhere on the child carrier 1.

[0042] FIG 7 illustrates the step of reversing the main pocket 35 to obtain the storage pocket 90. The entire folded baby carrier, including the deflated insert 50 (which is maintained in the secondary pocket 19), can then be folded and pushed into the storage pocket 90 as illustrated in FIGS 8 and 9. Finally, the storage pocket 90 is closed by zipping the zipper 36, so as to obtain a kind of pillow, as illustrated in FIG 10. In this form of pillow, the baby carrier 1 can be transported easily when not used. The storage pocket 90 can be closed with the same zipper 36 used for closing the main pocket 35, the zipper 36 being used inside-out.

[0043] A handle 91 may be provided on the storage pocket 91 to facilitate its transport. This handle 91 may be formed by a strap sewn at its ends on the outside of the storage pocket 90 (i.e. on the inside of the main pocket 35).

[0044] Apart from the insert 50, most of the elements constituting the child carrier 1 are made of synthetic fabrics, nylon or polyester, which can be easily folded (or rolled up, or balled up). The other elements like the pump 60, the valve 66, the buckles 16, 48, etc. are relatively small compared to the storage pocket 90 and the child carrier 1 does not have large and stiff elements. As a result, the entire child carrier 1 can be folded into a compact package that fits in the storage pocket 90.

[0045] The embodiments or examples described herein are given by way of illustration and not limitation. In light of this description, one skilled in the art could easily modify these embodiments or examples, or consider others, while remaining within the scope of the invention. For example, the size, shape, location or orientation of the various components can be changed as needed and/or desired. Components that are shown directly connected or contacting each other can have intermediate structures disposed between them. The functions of one element can be performed by two, and vice versa. One skilled in the art could easily consider variants including only some features of these embodiments or examples, if these features alone are sufficient to provide one of the advantages of the invention. Further, the features of the embodiments or examples disclosed herein can be used in varying combinations with each other, and are not intended to be limited to the specific combinations described herein. In particular, unless specified otherwise or technically incompatible, a feature described in relation with one embodiment or example can be applied analogously to another embodiment or example.

Claims

1. A child carrier adapted to be worn by a wearer for carrying a child, comprising:
- a hip belt (10) adapted to be secured about a waist of the wearer, and
a seat part (30) connected to the hip belt (10) and comprising:
- a seating surface (38) adapted to seat the child on,
a main pocket (35) located under the seating surface (38), and
an inflatable insert (50) deformable between an inflated state and a deflated state, the inflatable insert (50) providing shape to the seat part (30) when inserted into the main pocket (35) and inflated,
- wherein the main pocket (35) is reversible and configured to form a storage pocket (90) when turned inside out, the storage pocket (90) being configured to store the seat part (30), including the inflatable insert (50) in its deflated state, and the hip belt (10).
2. The child carrier of claim 1, further comprising a torso support part (20) for supporting the torso of the child, connected to the seat part (30), and at least one shoulder strap (21) for the wearer, connected to the torso support part (20), the storage pocket (90) being configured to store the torso support part (20) and the shoulder strap (21).
3. The child carrier of claim 1 or 2, wherein the seat part (30) comprises a wearer engagement surface (34) adapted to rest against a body of the wearer and an outer surface opposite to the wearer engagement surface (34), the main pocket being delimited by the seating surface (38), the wearer engagement surface (34) and the outer surface.
4. The child carrier of any one of claims 1 to 3, comprising a pump (60) which is integral with the inflatable insert (50), the inflatable insert (50) being inflated by operating the pump (60).
5. The child carrier of claim 4, wherein the pump (60) comprises a movable part (63) to be moved for operating the pump (60), and wherein the movable part (63) can be manually moved by the wearer through the outer surface of the seat part (30).
6. The child carrier of claim 5, wherein the outer surface of the seat part has a first textured area (32) having a different texture than a surrounding area of the outer surface, and wherein, when the inflatable insert (50) is in place inside the main pocket (35) and inflated or partly inflated, the first textured area (32) is located in front of the movable part (63) and the movable part (63) can be manually moved through the first textured area (32).
7. The child carrier of any one of claims 1 to 6, comprising a deflating valve (66) which is integral with the inflatable insert (50), the inflatable insert (50) being deflated by operating the deflating valve (66).
8. The child carrier of claim 7, wherein the deflating valve (66) is a normally closed valve which can be manually opened through the outer surface of the seat part (30).
9. The child carrier of claim 8, wherein the outer surface of the seat part (30) has a second textured area having a different texture than a surrounding area of the outer surface, and wherein, when the inflatable insert (50) is in place inside the main pocket (35) and inflated or partly inflated, the second textured area is located in front of the deflating valve (66) and the deflating valve (66) can be manually opened through the second textured area.
10. The child carrier of any one of claims 1 to 9, comprising a secondary pocket (19) configured to contain the inflatable insert (50) in its deflated state.
11. The child carrier of any one of claims 1 to 10, wherein the main pocket (35) has an openable opening (33), in particular a zip opening, located on the outer face of the seat part (30).
12. The child carrier of claim 11, wherein the main pocket (35) is made of a laminate structure comprising an outer textile layer and an inner textile layer, the outer textile layer being less resistant to wear and tear than the inner textile layer.

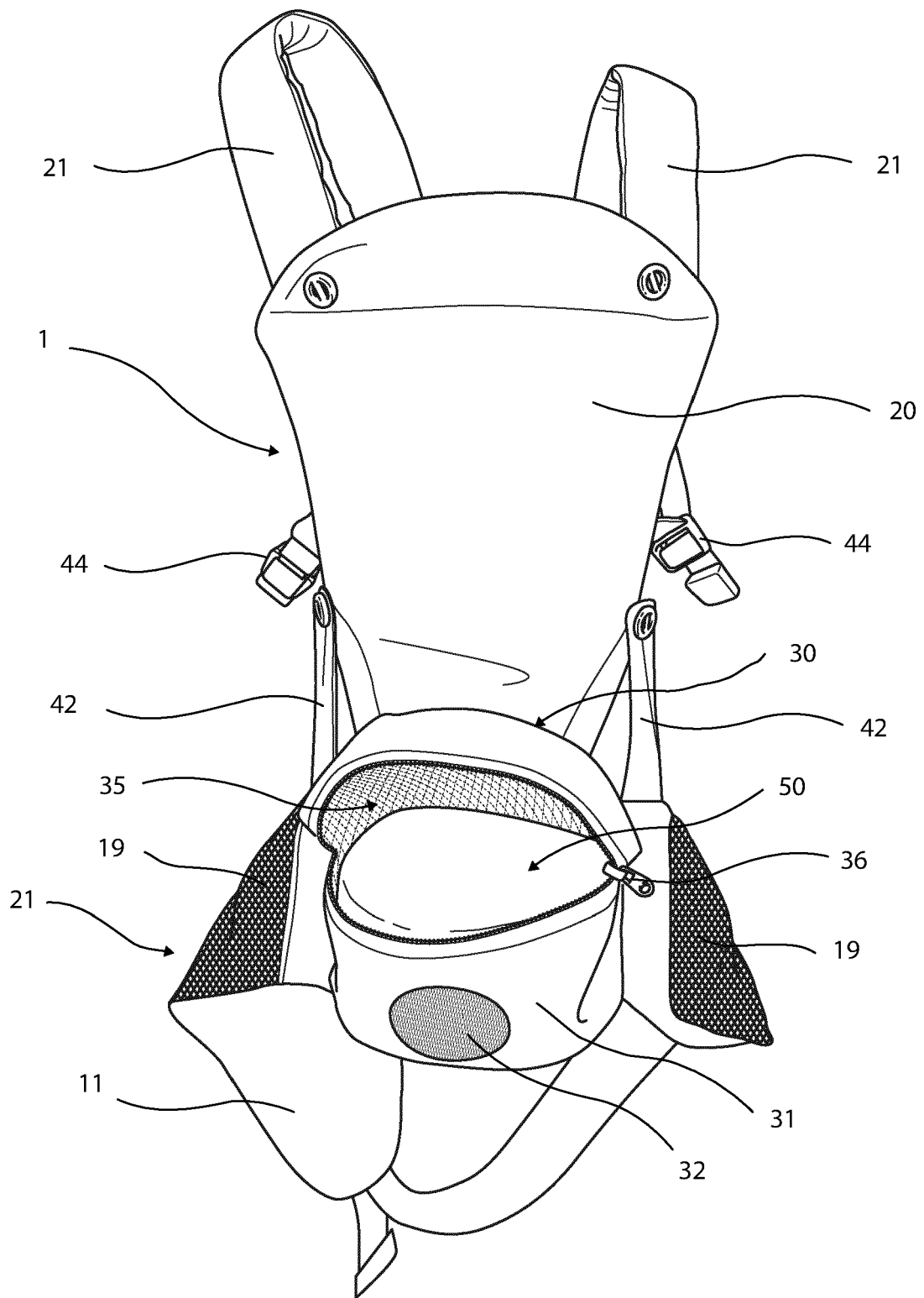

Fig. 1

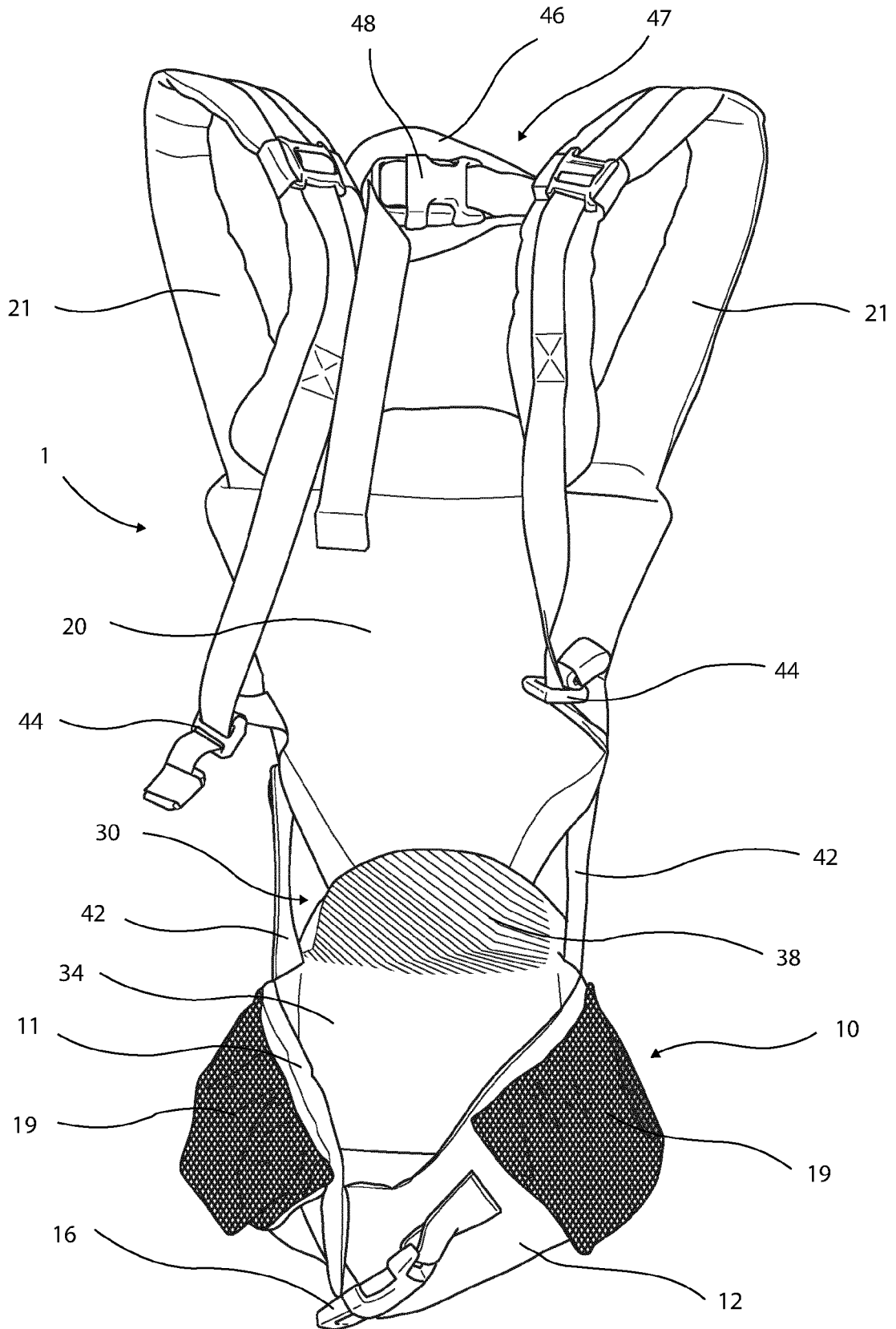
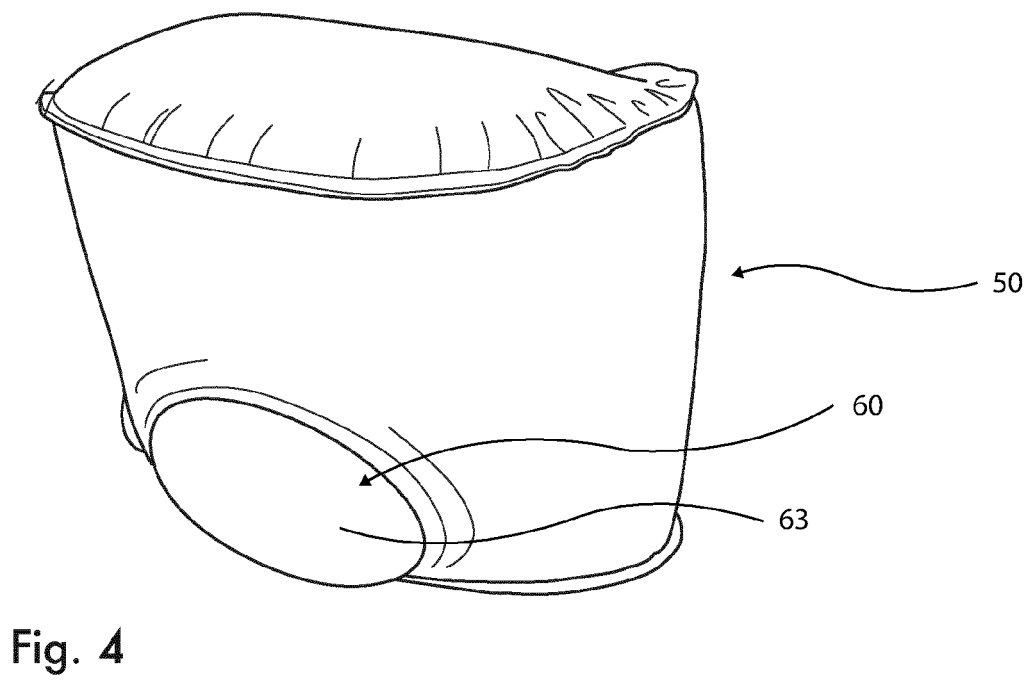
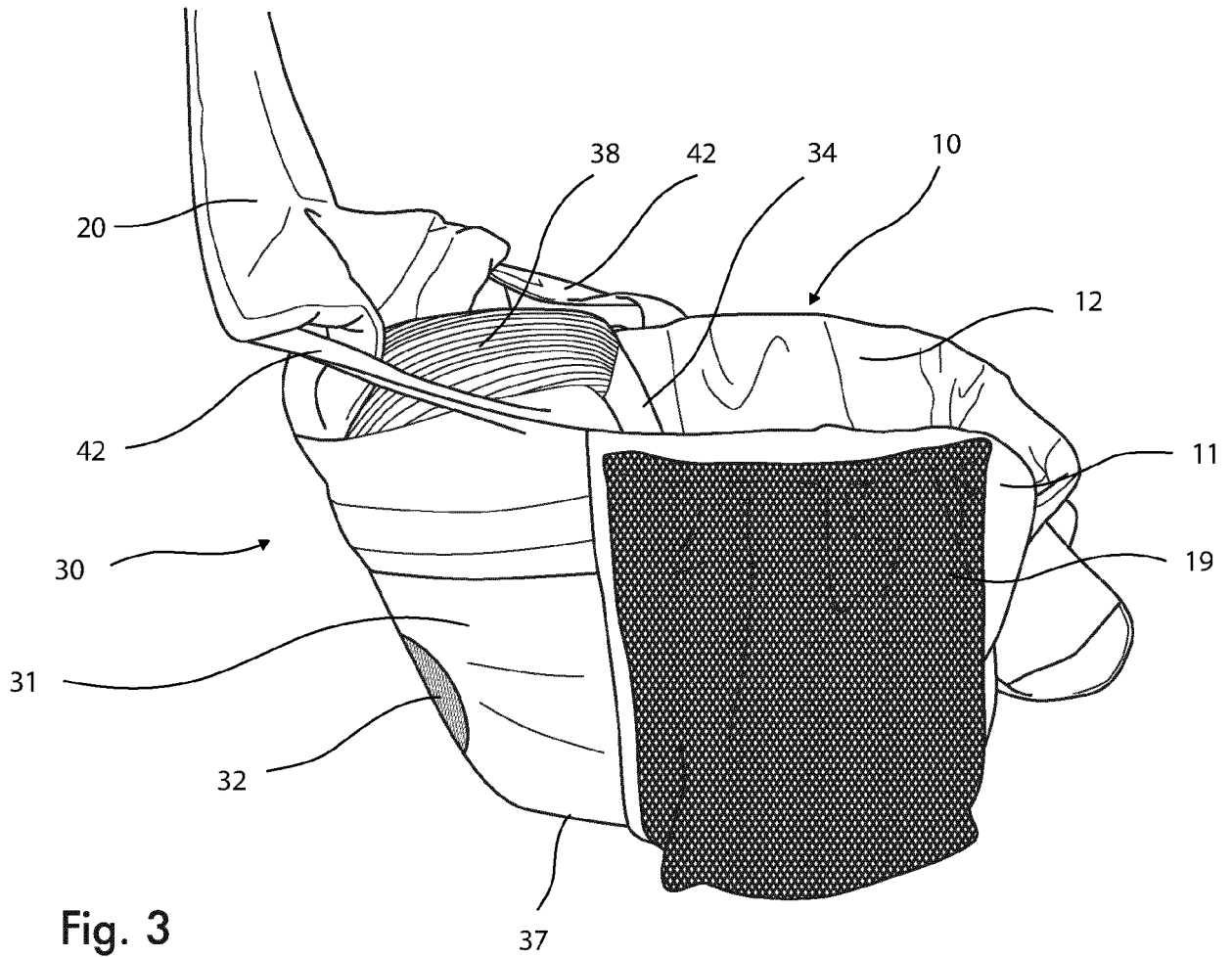

Fig. 2



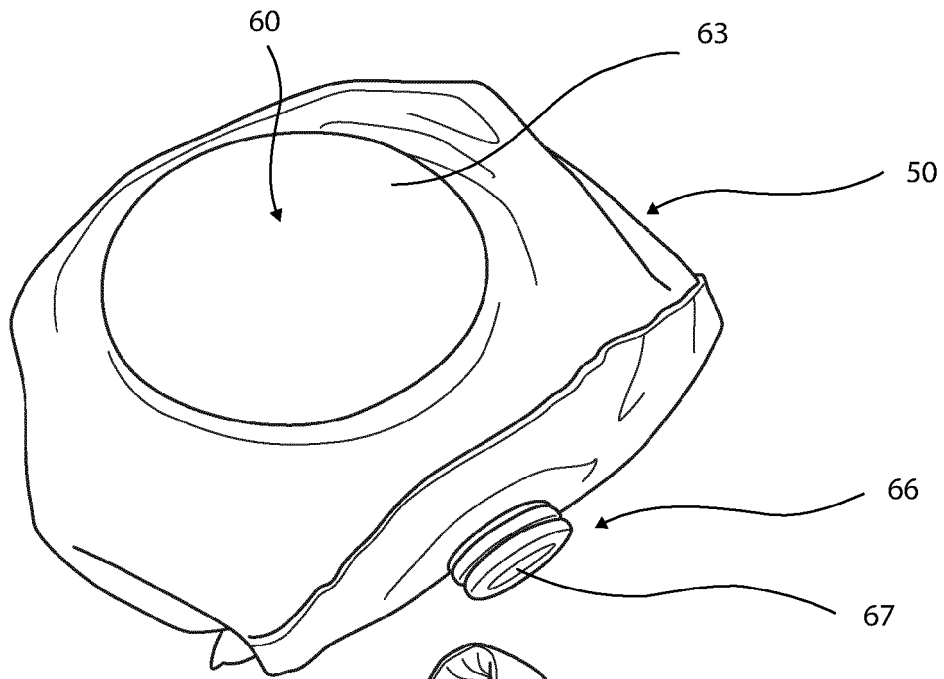

Fig. 5

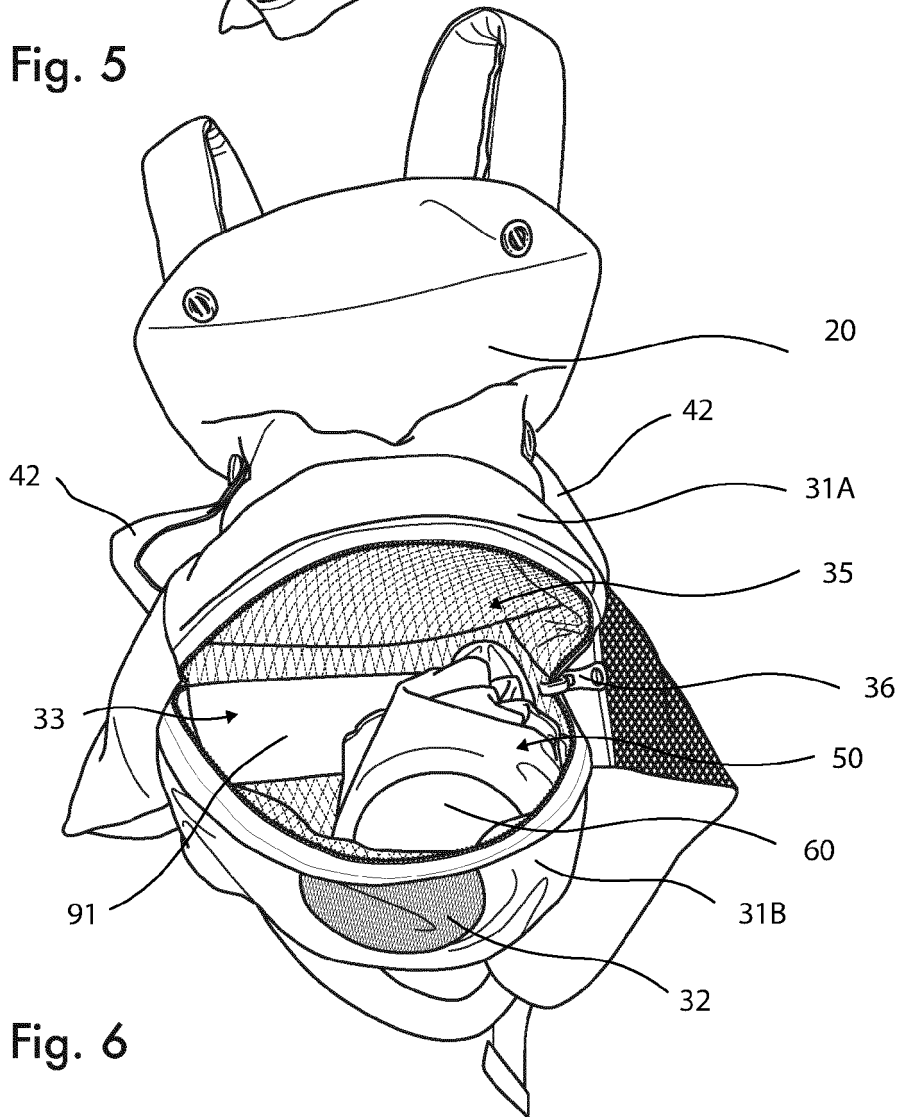

Fig. 6

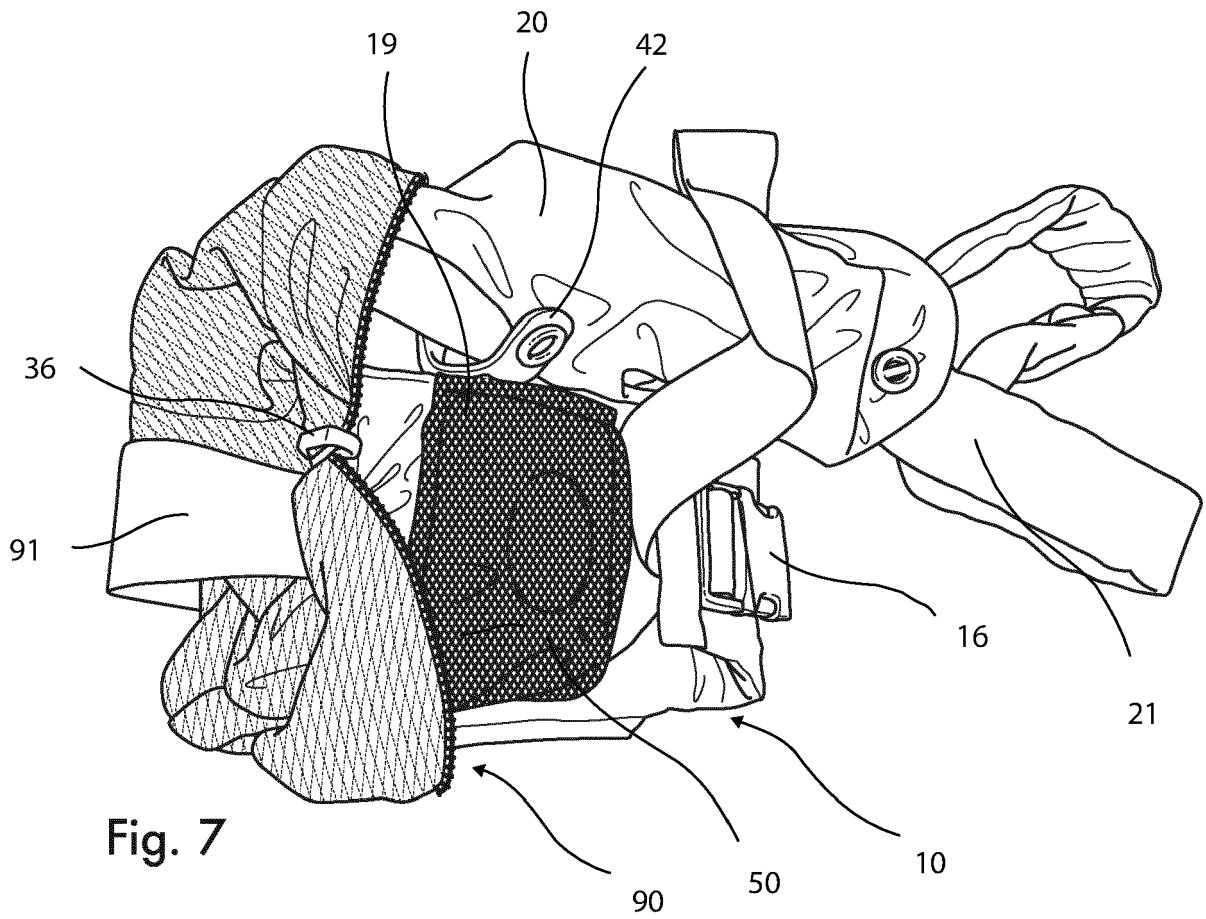

Fig. 7

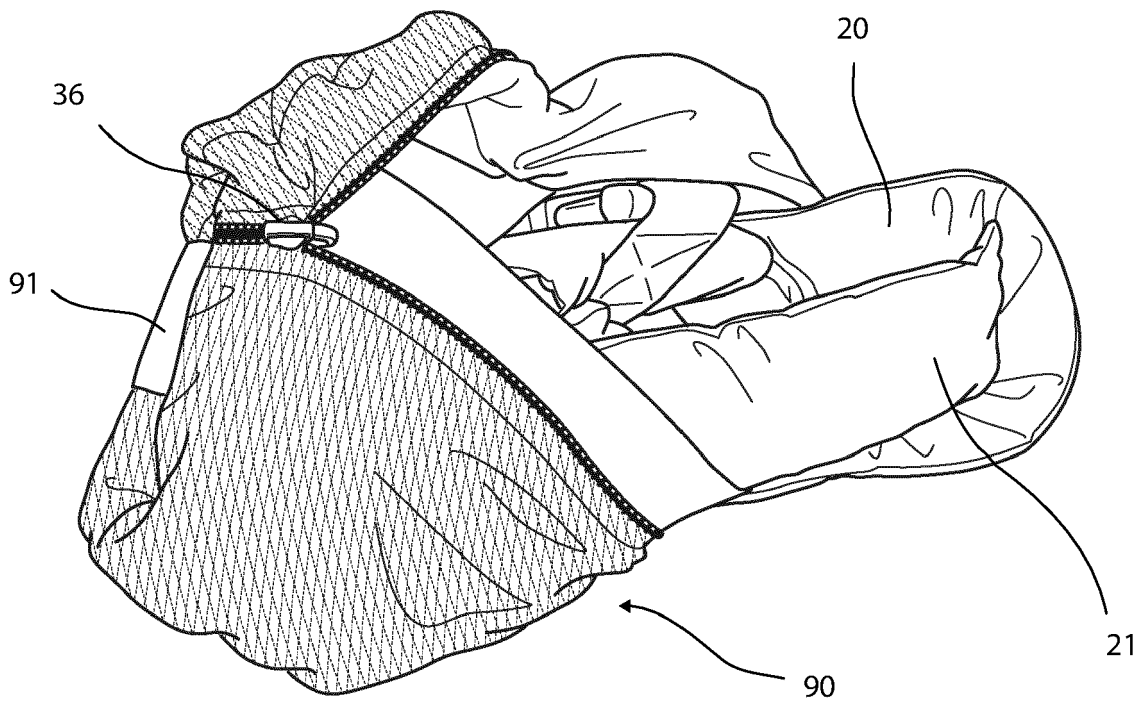

Fig. 8

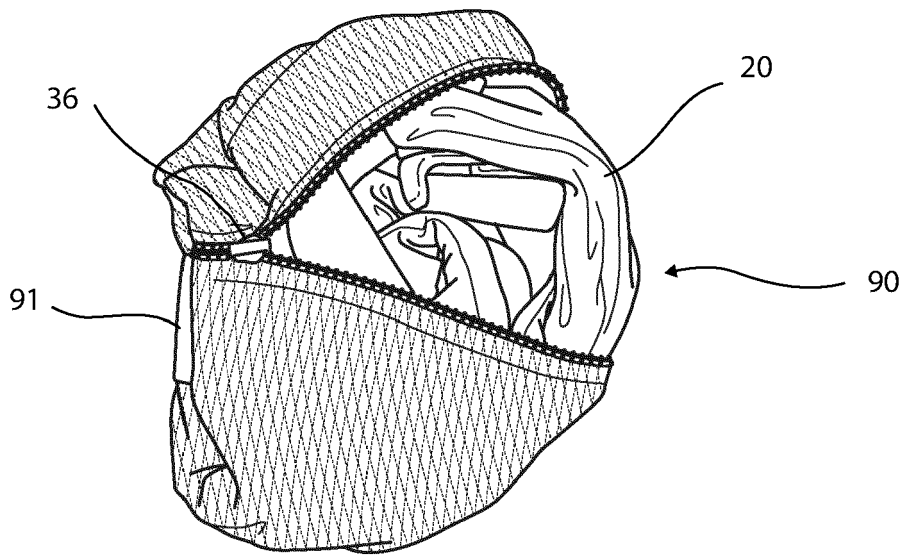

Fig. 9

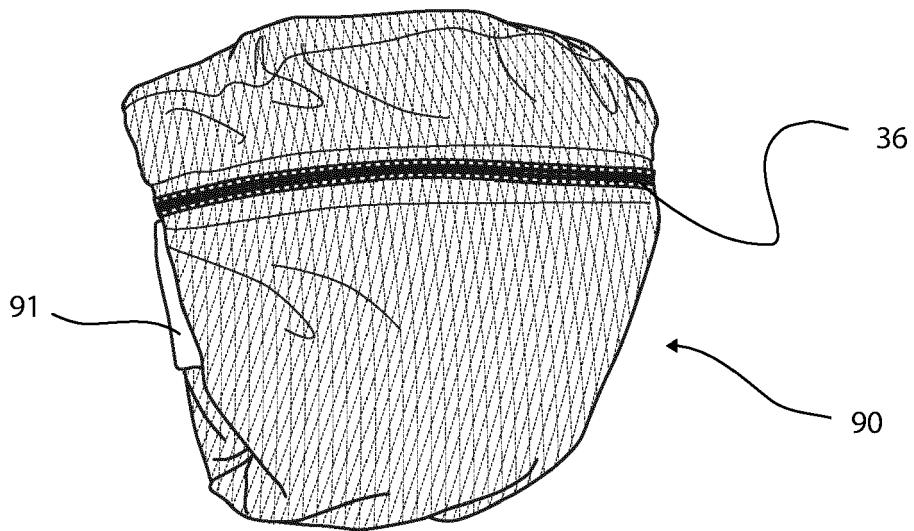

Fig. 10



EUROPEAN SEARCH REPORT

Application Number
EP 20 30 6323

5

10

15

20

25

30

35

40

45

50

55

DOCUMENTS CONSIDERED TO BE RELEVANT			
Category	Citation of document with indication, where appropriate, of relevant passages	Relevant to claim	CLASSIFICATION OF THE APPLICATION (IPC)
X	CN 209 219 702 U (XIAMEN QIANYANGHAO E COMMERCE CO LTD) 9 August 2019 (2019-08-09) * paragraph [0026]; figures 1-4 *	1-12	INV. A47D13/02
A	CN 211 795 507 U (YAN CHENGXIAO) 30 October 2020 (2020-10-30) * paragraphs [0021] - [0030]; figures 1-5 *	1-12	
A	US 2007/284403 A1 (MINAMI SAKIKO [JP] ET AL) 13 December 2007 (2007-12-13) * paragraphs [0183] - [0184]; figures 5, 8, 70-75 *	1-12	
			TECHNICAL FIELDS SEARCHED (IPC)
			A47D
The present search report has been drawn up for all claims			
Place of search		Date of completion of the search	Examiner
The Hague		25 March 2021	Pössinger, Tobias
CATEGORY OF CITED DOCUMENTS			
X : particularly relevant if taken alone Y : particularly relevant if combined with another document of the same category A : technological background O : non-written disclosure P : intermediate document		T : theory or principle underlying the invention E : earlier patent document, but published on, or after the filing date D : document cited in the application L : document cited for other reasons & : member of the same patent family, corresponding document	

EPO FORM 1503 03.02 (P04C01)

ANNEX TO THE EUROPEAN SEARCH REPORT
ON EUROPEAN PATENT APPLICATION NO.

EP 20 30 6323

5 This annex lists the patent family members relating to the patent documents cited in the above-mentioned European search report.
The members are as contained in the European Patent Office EDP file on
The European Patent Office is in no way liable for these particulars which are merely given for the purpose of information.

25-03-2021

Patent document cited in search report	Publication date	Patent family member(s)	Publication date
CN 209219702 U	09-08-2019	NONE	

CN 211795507 U	30-10-2020	NONE	

US 2007284403 A1	13-12-2007	CN 101044945 A	03-10-2007
		GB 2436735 A	03-10-2007
		GB 2476401 A	22-06-2011
		GB 2476402 A	22-06-2011
		GB 2476591 A	29-06-2011
		GB 2476592 A	29-06-2011
		HK 1105566 A1	22-02-2008
		JP 5026720 B2	19-09-2012
		JP 2007268073 A	18-10-2007
		KR 20070098746 A	05-10-2007
		TW 200735819 A	01-10-2007
		TW 201350059 A	16-12-2013
		TW 201350060 A	16-12-2013
		US 2007284403 A1	13-12-2007
