

(19)



(11)

**EP 4 015 963 B1**

(12)

**EUROPEAN PATENT SPECIFICATION**

(45) Date of publication and mention of the grant of the patent:  
**17.01.2024 Bulletin 2024/03**

(51) International Patent Classification (IPC):  
**F28D 9/00** <sup>(2006.01)</sup>      **F28F 3/04** <sup>(2006.01)</sup>  
**F28F 3/08** <sup>(2006.01)</sup>      **F28F 3/10** <sup>(2006.01)</sup>  
**F28F 9/00** <sup>(2006.01)</sup>

(21) Application number: **21214647.6**

(52) Cooperative Patent Classification (CPC):  
**F28D 9/005; F28D 9/0075; F28F 3/083; F28F 3/10;**  
**F28F 3/046; F28F 9/001; F28F 2240/00;**  
**F28F 2275/205**

(22) Date of filing: **15.12.2021**

(54) **SPACER INSERT FOR HEAT EXCHANGER**

ABSTANDSHALTEREINSATZ FÜR WÄRMETAUSCHER

INSERT D'ESPACEUR POUR ÉCHANGEUR DE CHALEUR

(84) Designated Contracting States:  
**AL AT BE BG CH CY CZ DE DK EE ES FI FR GB  
GR HR HU IE IS IT LI LT LU LV MC MK MT NL NO  
PL PT RO RS SE SI SK SM TR**

(72) Inventor: **NIELSEN, Helge**  
**6430 Nordborg (DK)**

(30) Priority: **16.12.2020 DK PA202070838**

(74) Representative: **Inspicos P/S**  
**Agern Allé 24**  
**2970 Hørsholm (DK)**

(43) Date of publication of application:  
**22.06.2022 Bulletin 2022/25**

(56) References cited:  
**WO-A1-96/30711      FR-A1- 2 638 226**  
**US-A1- 2020 271 387**

(73) Proprietor: **Danfoss A/S**  
**6430 Nordborg (DK)**

**EP 4 015 963 B1**

Note: Within nine months of the publication of the mention of the grant of the European patent in the European Patent Bulletin, any person may give notice to the European Patent Office of opposition to that patent, in accordance with the Implementing Regulations. Notice of opposition shall not be deemed to have been filed until the opposition fee has been paid. (Art. 99(1) European Patent Convention).

## Description

### BACKGROUND

**[0001]** A traditional construction of a plate heat exchanger comprises a plurality of heat transfer plate stacked on top of each other. The heat transfer plates are formed with patterns such that flow paths are formed between each set of neighboring heat transfer plates. Inlets and outlets for fluids to the flow paths may be formed as openings in the heat transfer plates. Some heat exchangers have the plates brazed together, whereas in others heat exchangers gaskets are positioned between the heat transfer plates in gasket grooves formed in the heat transfer plates. The gasket then is arranged at an edge portion of the heat transfer plate to seal the flow paths and at an area around the openings to seal pairs of the openings, such that only two of them have flow access to the flow path formed at one side of the heat transfer plate, while the other two is sealed therefrom. Frame plates may be connected and fastened to the stack of heat exchangers plates, such as at the top and bottom, and has a significant thickness compared to the heat transfer plates to take up great loads.

**[0002]** It is a known problem for gasket heat exchangers, that the gasket tends to be deformed and/or pressed slightly out of position. A further problem is the heat transfer plates traditionally are shaped with patterns at the rim and in the opening areas, in addition to the patterns in the heat transfer sections. This often makes the plate quite complex plate to manufacture and increases the possibility of misalignment when assembled in the heat exchanger. It also increases the possibility for introducing weak spots or areas in the plates. The present invention aims to overcome such problems.

**[0003]** US 2020/271387 A discloses a spacer with the features of the preamble of claim 1.

### SUMMARY OF THE INVENTION

**[0004]** To solve such problems the present invention introduces a spacer adapted to be sandwiched between the rim regions of two adjacent heat transfer plates of a plate heat exchanger as defined in claim 1.

**[0005]** The inner hollow may be adapted for the two heat transfer plates to contact in a heat transferring area defined by said two connected heat transfer plates.

**[0006]** The spacer may be adapted to prevent the two heat transfer plates to contact in the rim regions.

**[0007]** The spacer may comprise a base part with a base part outer gasket-free section wherein the base part outer gasket-free section is formed with spacer bar openings adapted to be aligned with plate bar openings formed in a plate rim region.

**[0008]** The spacer bar openings may be adapted for bars to reach through the stack of heat transfer plates between two frame plates.

**[0009]** The spacer may include spacer openings

adapted to be aligned with the plate openings.

**[0010]** The spacer may be formed with a base part inner gasket section defining the inner side of a spacer opening (114, 115) relative to the inner hollow (105) and adapted to be positioned in a diagonal area of a heat transfer plate (11) and adapted to prevent flow passing between a plate opening (14, 15) and the heat transferring area (13).

**[0011]** The spacer is formed with porous diagonal support sections defining the inner side of a spacer opening relative to the inner hollow and adapted to be positioned in a diagonal area of a heat transfer plate and adapted to allow flow passing between a plate opening and the heat transferring area.

**[0012]** The porosity of the porous diagonal support may be ensured by diagonal spacer flow paths formed between diagonal spacer supports adapted to contact the two neighbouring heat transfer plates.

**[0013]** The porous diagonal support may be formed of two connected concentric semi-circular parts adapted to be positioned in a diagonal area when connected to a heat transfer plate.

**[0014]** The spacer may comprise a base part with a base part outer gasket-free section wherein the base part outer gasket-free section is formed with poka-yoke projecting features adapted to fit with poka-yoke receiving features formed in the heat transfer plates.

**[0015]** The spacer is adapted to form support for a gasket.

**[0016]** The spacer may comprise a base part with a base part outer gasket-free section wherein the gasket is positioned at in inside location of the outer gasket-free section.

**[0017]** The spacer may be substantially more rigid and incompressible than the gasket material.

**[0018]** The present invention further introduces a heat exchanger formed of a stack of structured heat transfer plates each provided with two pairs of openings, each pair providing an inlet and outlet to respectively a first flow path at the one side and a second flow path at the second side of the heat transfer plate, and where a spacer according to any of the preceding claims is positioned between at least two adjoining neighbouring heat transfer plates in a plate rim region.

### FIGURES

#### **[0019]**

- 50 Fig. 1 Gasket type plate heat exchanger and heat transfer plate according to prior art.
- Fig. 2 Illustration of elements of spacers with gasket and heat transfer plates
- 55 Fig. 3 Illustration of a spacer with integrated gasket

- Figs. 4A, 4B Illustration of the top and bottom views of a part of a spacer with integrated gasket in the diagonal areas
- Fig. 5 Heat transfer plate adapted for a spacer and gasket
- Figs. 6A, 6B Illustration of a gasket connected to a side of a spacer

#### DETAILED DESCRIPTION OF THE INVENTION

**[0020]** Fig. 1 shows one example of a plate heat exchanger (10) formed of a collection, or stack, of structured heat transfer plates (11). Each of the heat transfer plates (11) is provided with two pairs of openings, where a first pair (14) provides an inlet and outlet for a first flow path formed at the one side of the heat transfer plate (11), and the second pair (15) provides an inlet and outlet for a second flow path formed at the second side of the heat transfer plate (11), the second side being opposite the first side. The openings (14, 15) of the stacked heat transfer plates (11) forming channels through the plate stack. In the illustrated example the heat transfer plates (11) at a rim portion is adapted to accommodate a gasket (12) to respectively seal the flow paths formed between each two neighbouring plates (11) from the externals, and to seal one pair of openings (14, 15)- where at the opposite side of the heat transfer plate (11) the respective other pair (15, 14) is sealed. Further the plate stack is arranged between two frame plates (50) being held together by bars (52) keeping the heat transfer plates (11) tight together under compression. At least one of the frame plates (50) include openings (51) aligned to the heat transfer plate openings (14, 15) and to be connected to external fluid pipes.

**[0021]** The heat transfer plates (11) being in direct contact with the fluids may be substantially thin to enable a fast exchange of heat between respectively a hot and cold fluid and are made of materials resistant to the media.

**[0022]** The frame plates (50) are relatively thick compared to the heat transfer plates (11) to withstand both the internal forces from the compressed stack of heat transfer plates (11), and what external impacts they may encounter.

**[0023]** The rim portion of the heat transfer plates (11) traditionally are patterned, such as by corrugations, to contact patterns of the adjoining neighbouring heat transfer plates (11), and to form a barrier for the gasket (12). The patterns may be connected by sections forming a wall against which the gasket (12) rests.

**[0024]** The gasket (12) positioned at the perimeter of the first and second flow paths formed between the connected heat transfer plates (11) including the heat transfer area (13), thus sealing the flow paths and heat transfer area (13) from the external of the heat exchanger (10).

**[0025]** The gasket (12) further is formed with gasket

diagonal sections (12A) positioned the diagonal areas of the heat transfer plates (11). A diagonal area is the intersection between an opening (14, 15) and the heat transferring area (13). A gasket (12) at the one side of the provides a gasket diagonal section (12A) for the second pair (15, 14) of openings, sealing them from the first flow path, and a gasket (12) at the second side provides a gasket diagonal second (12A) for the first pair (14, 15) of openings, sealing them from the second flow path.

**[0026]** Fig. 2 illustrates an alternative gasket kind heat exchanger (10) where spacers (100), or gasket units (100), are positioned between the heat transfer plates (11) in a plate rim region (16). The figure illustrates the parts in the heat exchanger (10) and not the parts when fully assembled into a heat exchanger (10).

**[0027]** In the following, when referring to spacer (100) it would also refer to a gasket unit (100) and vice versa.

**[0028]** The spacer (100) may be formed with a base part (101) that comprises an outer gasket-free section (101A) and inner gasket section (101B) with the gasket (102). The outer gasket-free section (101A) may be formed assisting means (19, 119, 120, 118) such as alignment/guiding means (19, 119, 120) for guiding the spacer (100) into the correct orientation and position, and/or connection or locking means (118) for connecting or locking the spacer (100) in position. Both sections (101A, 101B) are adapted to contact the two heat transfer plates (11) when stacked into a heat exchanger (11), but where only the gasket is adapted to be compressed between the two heat transfer plates (11). This enables the base part (101) including the outer gasket-free section (101) to form the support for the plate rim regions (16), and the gasket (12) in the inner gasket section (101B) to form the seal of the inner heat transferring area (13) towards the externals, and the outer gasket-free section (101).

**[0029]** The outer gasket-free section (101A) may constitute a width being at least 2/3 of the full width of the spacer (100), or even 3/4 or 4/5. Correspondingly, the inner gasket section (101B) may constitute a width being less than or equal to 1/3, or 1/4 or 1/5 of the full width of the spacer (100).

**[0030]** A spacer (100) may be positioned between a frame plate (50) and the adjoining heat transfer plate (11), and between the individual heat transfer plates (11). Spacers (100) may be positioned between some of the heat transfer plates (11) or all of them.

**[0031]** The spacer (100) replaces the contact patterns traditionally formed at the rim portion of the heat transfer plates (11) for contacting patterns of the adjoining neighbouring heat transfer plates (11). The plate rim region (16) formed outside the heat transferring area (13) thus need not be patterned, but could be essentially flat, or plane, or at least not having sections or areas being in contact with neighbouring plates.

**[0032]** The assisting means of the spacer (100) may include spacer bar openings (118), such as formed in the outer gasket-free section (101A), adapted to be aligned

with plate bar openings (18) formed in the plate rim region (16). These form means for connecting or locking the spacers (100) in position. When the heat transfer plates (11) is stacked with the spacers (100) in-between, and with frame plates (50) on top and bottom. Bars then can be introduced through the spacer bar openings (118), plate bar openings (18) and openings in the frame plates. The parts then can be held in tight connection e.g. by bolts positioned at the ends of the bars. This has the additional advantage of keeping the spacers (100) fixed in position.

**[0033]** In one embodiment connecting or locking means of the assisting means could be formed as a feature of the outer gasket-free section (101A) projection upwards adapted to fit into an opening or projection formed in the rim regions (16).

**[0034]** An inner hollow (103) is formed within the spacer (100) and encircled by the base part (101) and gasket (102). Where the base part (101) is adapted to be sandwiched between the rim regions (16) of two adjacent heat transfer plates (11) of a plate heat exchanger (10), the inner hollow (103) is adapted for the two heat transfer plates (10) to contact in a heat transferring area (36) defined by said two connected heat transfer plates (11).

**[0035]** Fig. 3 shows the spacer (100) including two pair spacer openings (114, 115) adapted to be aligned with the plate openings (14, 15).

**[0036]** The gasket (102, 102A, 102B) is incorporated as a part of the spacer (100), making it a gasket unit (100), or is fixed thereto, or is possible inserted into recesses or grooves formed in the spacer (100) surface. The gasket (102, 102A, 102B) could e.g. be moulded to the spacer (100), such as by injection moulding.

**[0037]** To assist the assembly and ensure a correct orientation of the spacer (100), the assisting means may include poka-yoke projecting features (120) adapted to fit with poka-yoke receiving features (19) formed in the heat transfer plates (11), such as in the plate rim region (16). The shape and/or of the poka-yoke projecting features (120) and associated plate poka-yoke receiving features (19) is such that only a correct orientation and positioning of the spacer (100) relative to the heat transfer plate (11) is possible. In an alternative embodiment the heat transfer plate (11) is formed with the poka-yoke projecting features (120) and the spacer (100) with the poka-yoke receiving feature (19). In any embodiment the spacer (100) could be provided with poka-yoke receiving features (119) adapted to align with the plate poka-yoke receiving features (19).

**[0038]** Not all surfaces of the spacer (100) need to be in contact with the heat transfer plates (11), it could e.g. comprise contact sections (130), such as raised edges along the edge of the spacer (100), around the rims of spacer bar openings (118), by projections, or just as projections. In the same manner the spacer as such could be or formed with a lattice formation or in general just being hollow at the external part relative to the gasket (102, 102A, 102B). This reduces the amount of material used for the spacer (100) and lowers the weight.

**[0039]** Fig. 4A shows a section of the spacer (100) in the area of two spacer openings (114, 115), a first spacer opening (114) for the first flow path, and second spacer opening (115) for the second flow path.

5 **[0040]** The spacer (100) may include a sealed diagonal support (104) section connecting the main part of the spacer (100) at two positions at opposite sides of a spacer opening (114, 115). The sealed diagonal support (104) is provided with a diagonal section (102A) of the gasket, which in the same manner connects to the main gasket (102) at two positions at opposite sides of the spacer opening (114, 115). The sealed diagonal support (104) is adapted to be positioned in a diagonal section of a heat transfer plate (11), and thus forms a separation wall between the spacer opening (114, 115) and the inner hollow (103), and thus when sandwiched between two heat transfer plates (11) in an assembled heat exchanger, forms a seal between the plate opening (14, 15) and heat transfer area (13).

20 **[0041]** In traditional heat exchanger the heat transfer plates (11) may be formed with a pattern contacting the neighboring heat transfer plates (11) for support, leaving channels or openings for the fluid to pass.

25 **[0042]** In this embodiment the diagonal areas of the heat transfer plates (11) need not be formed with any supporting structures or patterns, but could be essentially flat or plan, or at least not be in direct contact with the neighboring heat transfer plates (11).

30 **[0043]** A second gasket (102B) connected to the support (100) may be formed to circumference of a spacer opening (114, 115) and may be separated from the gasket (112) and diagonal gasket section (112A) or connected to either of them. As illustrated, the main part of the gasket (112) and the diagonal gasket section (112A) may extend as one continuous part without a section at the outer side of the spacer openings (114, 115). In an alternative embodiment the main gasket part (112) perimeters the spacer (100) and all the spacer openings (114, 115) and the diagonal gasket section (112A) extend at the inside of the openings (114, 115) to be sealed from the inner hollow (105) like a branch connecting the main gasket (112) part at two sides of the respective openings (114, 115).

45 **[0044]** The spacer (100) comprises supporting means (103) for the areas adapted to support the areas of the heat transfer plates (11) of the openings (14, 15) of the heat transfer plates (11) to be unsupported by a gasket, to allow flow passing the heat transferring area (13). This is formed as porous diagonal support (103) section(s). This part is adapted to support the heat transfer plates (11) in otherwise unsupported sections, such as the diagonal areas associated with the plate openings (14, 15) where flow is to pass to and from the heat transferring area (13). In traditional heat exchanger the heat transfer plates (11) in this area may be formed with a pattern contacting the neighboring heat transfer plates (11) for support, leaving channels or openings for the fluid to pass.

**[0045]** In this embodiment the diagonal areas of the heat transfer plate (11) need not be formed with any supporting structures or patterns, but could be essentially flat or plan, or at least not be in direct contact with the neighboring heat transfer plates (11).

**[0046]** In the illustrated embodiment the porosity of the porous diagonal support (103) is ensured by diagonal spacer flow paths (103A) formed between diagonal spacer supports (103B) adapted to contact the two neighbouring heat transfer plates (11). The diagonal spacer flow paths (103A) could be formed in any manner, such as holes or pores on an otherwise solid porous diagonal support (103), as the free sections between the diagonal spacer supports (103B) or in any other form.

**[0047]** Fig. 4B shows the other side of the support (100) relative to fig. 4A, where the one side of the porous diagonal support (103) is seen having a flat surface forming a common diagonal support part (103B) contacting the surface of one of the heat transfer plates (11), at the other side being formed with the pillar like diagonal support parts (103B) to contact the adjoining neighbouring heat transfer plate (11).

**[0048]** In the illustrated embodiment the porous diagonal support (103) is formed of two connected concentric semi-circular parts positioned in a diagonal area and contacts the main part of the spacer (100) at the opposite sides of a spacer opening (114, 115).

**[0049]** The spacer (100) may be formed with the gasket (102, 102A, 102B) at both surfaces, thus having a gasket (102, 102A, 102B) part, or a gasket surface, contacting both the upper and lower of the two adjoining neighbouring heat transfer plates (11). In one embodiment a gasket (102, 102A, 102B) is positioned or formed at both surfaces.

**[0050]** As previously indicated, the gasket (102) may be positioned at an inner rim portion of the spacer (100), such as at a base part inner gasket section (101B), such that the portion external to the heat transferring area (13), such as the base part outer gasket-free section (101A), can be formed with openings etc., such as the spacer bar openings (118). This ensures these openings are sealed from the flow paths within the heat exchanger (10).

**[0051]** In one embodiment the base part (101) is formed of two individual parts, the base part outer gasket-free section (101A) positioned at the outside of a base part inner gasket section (101B). The outer base part outer gasket-free section (101A) thus forms an outer support for the base part inner gasket section (101B) holding it in position, where the outer base part gasket-free section (101A) could be fixed such as by the bars (52).

**[0052]** In another embodiment the gasket (12, 112) is positioned against the inside edge surface of the outer base part gasket-free section (101A), this thus forming the spacer (100) and outer support for the gasket (12, 112). In this embodiment the inner edge surface possible could be shaped to match the shape of the gasket (12, 112).

**[0053]** In one embodiment a gasket unit (100) is intro-

duced with the base part (101) includes a base part inner gasket section (101B) with the gasket (102, 102A, 102B). The rigidity of the base part (101) then would assist in keeping the gasket (102, 102A, 102B) in position, and the concept could be combined with the traditional corrugations in the plate rim region (16) at the outside of the gasket unit (100), which would prevent it from being squeezed out of position under the pressures in the heat exchanger (10).

**[0054]** Fig. 5 shows an embodiment heat transfer plate (11) adapted to be assembled into a heat exchanger (10) with spacers (100) in-between, where in addition to the projections or corrugations defining the flow paths in the heat transferring area (13), the outer rim portion is bent (17). The bend outer rim (17) may contact the outer surface of the spacer (100) when stacked, and thus assist in keeping it in position. A further advantage is the bend outer rim (17) assists in guiding the heat transfer plate (11) into position when assembling the heat exchanger (10).

**[0055]** The bend section (17) may be smooth as illustrated, or may itself be formed, such as having a wavy or corrugated shape to increase strength.

**[0056]** Fig. 6A and 6B shows an embodiment where a free gasket (102) is adapted to be connected to the spacer (100), such as to its inner side facing the inner hollow (105). In the illustrated embodiment the spacer (100) is formed with a connection section (100A) adapted to fit with a gasket connection section (102C). Either of the spacer connection section (100A) or gasket connection section (102C) could be formed as an extension (100A) adapted to fit into the recess (102C) of the other. In the illustration the spacer (100) is provided with the extension, and the gasket (102) with the recess, but the reverse is also possible.

**[0057]** In one embodiment the parts such as the porous diagonal support (103) including the diagonal spacer supports (103B), and/or the sealed diagonal support (104) is formed by the same material as the gasket. In the embodiment where the gasket (102) is positioned at the inner surface facing the inner hollow (105), the porous diagonal support (103) including the diagonal spacer supports (103B), and/or the sealed diagonal support (104), could be formed as a part of the gasket (102) rather than the spacer (100).

List of references:

**[0058]**

- 10 - Plate heat exchanger
- 11 - Heat transfer plates
- 12 - Gasket
- 12A - Gasket diagonal section
- 13 - Heat transferring area
- 14 - Opening for first flow path
- 15 - Opening for second flow path
- 16 - Plate rim region

17 - Outer bend plate rim section  
 18 - Plate bar opening  
 19 - Poke yoke plate receiving feature  
 50 - Frame plate  
 51 - Frame plate openings  
 52 - Bars and bolts  
 100 - Spacer insert/gasket unit  
 100A - Spacer connection section  
 101 - Base part  
 101A - Base part outer gasket-free section  
 101B - Base part inner gasket section  
 102 - Gasket  
 102A - Gasket diagonal section  
 102B - Second gasket  
 102C - Gasket connection section  
 103 - Porous diagonal support (section)  
 103A - Diagonal spacer flow paths  
 103B - Diagonal spacer supports  
 104 - Sealed diagonal support (section)  
 105 - Inner hollow  
 114 - Spacer opening for first flow path  
 115 - Spacer opening for second flow path  
 118 - Spacer bar openings  
 119 - Poke yoke insert receiving feature  
 120 - Poke yoke projecting feature  
 130 - Contact sections

### Claims

1. A spacer (100) adapted to be sandwiched between the rim regions (16) of two adjacent heat transfer plates (11) of a plate heat exchanger (10), where the spacer is formed with a gasket (102, 102A, 102B) in the surface adapted to encircle an inner hollow (105) of said spacer (100), and **characterised in that** the spacer (100) is formed with porous diagonal support (103) sections defining the inner side of a spacer opening (114, 115) relative to the inner hollow (105) and adapted to be positioned in a diagonal area of a heat transfer plate (11) and adapted to allow flow passing between a plate opening (14, 15) and the heat transferring area (13).
2. A spacer (100) according to claim 1, wherein the inner hollow (105) is adapted for the two heat transfer plates (10) to contact in a heat transferring area (13) defined by said two connected heat transfer plates (11).
3. A spacer (100) according to claim 1 or 2, wherein the spacer (100) is adapted to prevent the two heat transfer plates (11) to contact in the rim regions (16).
4. A spacer (100) according to claim 1, 2 or 3, wherein the spacer (100) comprises a base part (101) with a base part outer gasket-free section (101A) wherein the base part outer gasket-free section (101A) is formed with spacer bar openings (118) adapted to be aligned with plate bar openings (18) formed in a plate rim region (16).
5. A spacer (100) according to claim 4, wherein the spacer bar openings (118) are adapted for bars (52) to reach through the stack of heat transfer plates (11) between two frame plates (50).
6. A spacer (100) according to any of the preceding claims, wherein the spacer (100) including spacer openings (114, 115) adapted to be aligned with the plate openings (14, 15).
7. A spacer (100) according to claim 6, wherein the spacer (100) is formed with a base part inner gasket section (101B) defining the inner side of a spacer opening (114, 115) relative to the inner hollow (105) and adapted to be positioned in a diagonal area of a heat transfer plate (11) and adapted to prevent flow passing between a plate opening (14, 15) and the heat transferring area (13).
8. A spacer (100) according to any of the preceding claims, wherein the porosity of the porous diagonal support (103) is ensured by diagonal spacer flow paths (103A) formed between diagonal spacer supports (103B) adapted to contact the two neighbouring heat transfer plates (11).
9. A spacer (100) according to claim 8, wherein the porous diagonal support (103) is formed of two connected concentric semi-circular parts adapted to be positioned in a diagonal area when connected to a heat transfer plate (11).
10. A spacer (100) according to any of the preceding claims, wherein the spacer (100) comprises a base part (101) with a base part outer gasket-free section (101A) wherein the base part outer gasket-free section (101A) is formed with poka-yoke projecting features (120) adapted to fit with poka-yoke receiving features (19) formed in the heat transfer plates (11).
11. A spacer (100) according to any of the preceding claims, wherein the spacer is adapted to form support for a gasket (12, 112).
12. A spacer (100) according to claim 11, wherein the spacer (100) comprises a base part (101) with a base part outer gasket-free section (101A) wherein the gasket is positioned at an inside location of the outer gasket-free section (101A).
13. A spacer (100) according to claim 11 or 12, wherein the spacer (100) is substantially more rigid and incompressible than the gasket (102, 102A, 102B) material.

14. A heat exchanger (10) formed of a stack of structured heat transfer plates (11) each provided with two pairs of openings (14, 15), each pair providing an inlet and outlet to respectively a first flow path at the one side and a second flow path at the second side of the heat transfer plate (11), and where a spacer (100) according to any of the preceding claims is positioned between at least two adjoining neighbouring heat transfer plates (11) in a plate rim region (16).

### Patentansprüche

1. Abstandhalter (100), der dazu eingerichtet ist, zwischen den Randbereichen (16) zweier angrenzender Wärmeübertragungsplatten (11) eines Plattenwärmetauschers (10) angeordnet zu sein, wobei der Abstandhalter mit einer Dichtung (102, 102A, 102B) in der Fläche ausgebildet ist, die dazu eingerichtet ist, einen Hohlraum (105) des Abstandhalters (100) zu umschließen, und **dadurch gekennzeichnet, dass** der Abstandhalter (100) mit porösen diagonalen Trägerabschnitten (103) ausgebildet ist, welche die Innenseite einer Abstandhalteröffnung (114, 115) in Bezug zum Hohlraum (105) definieren und dazu eingerichtet sind, in einem diagonalen Bereich einer Wärmeübertragungsplatte (11) positioniert zu sein, und dazu eingerichtet sind, eine Strömung zwischen einer Plattenöffnung (14, 15) und dem Wärmeübertragungsbereich (13) passieren zu lassen.
2. Abstandhalter (100) nach Anspruch 1, wobei der Hohlraum (105) dazu eingerichtet ist, dass die zwei Wärmeübertragungsplatten (10) einander in einem Wärmeübertragungsbereich (13) berühren, der durch die zwei verbundenen Wärmeübertragungsplatten (11) definiert ist.
3. Abstandhalter (100) nach Anspruch 1 oder 2, wobei der Abstandhalter (100) dazu eingerichtet ist, zu verhindern, dass die zwei Wärmeübertragungsplatten (11) einander in den Randbereichen (16) berühren.
4. Abstandhalter (100) nach Anspruch 1, 2 oder 3, wobei der Abstandhalter (100) einen Basisteil (101) mit einem äußeren, dichtungsfreien Basisteilabschnitt (101A) umfasst, wobei der äußere, dichtungsfreie Basisteilabschnitt (101A) mit Abstandsstangenöffnungen (118) ausgebildet ist, die dazu eingerichtet sind, mit Plattenstangenöffnungen (18) ausgerichtet zu sein, die in einem Plattenrandbereich (16) ausgebildet sind.
5. Abstandhalter (100) nach Anspruch 4, wobei die Abstandhalterstangenöffnungen (118) dazu eingerichtet sind, dass Stangen (52) durch den Stapel aus Wärmeübertragungsplatten (11) zwischen zwei

Rahmenplatten (50) hindurch reichen.

6. Abstandhalter (100) nach einem der vorstehenden Ansprüche, wobei der Abstandhalter (100) Abstandhalteröffnungen (114, 115) umfasst, die dazu eingerichtet sind, mit den Plattenöffnungen (14, 15) ausgerichtet zu sein.
7. Abstandhalter (100) nach Anspruch 6, wobei der Abstandhalter (100) mit einem inneren Basisteildichtungsabschnitt (101B) ausgebildet ist, der eine Innenseite einer Abstandhalteröffnung (114, 115) in Bezug zum Hohlraum (105) definiert und dazu eingerichtet ist, in einem diagonalen Bereich einer Wärmeübertragungsplatte (11) positioniert zu sein, und dazu eingerichtet ist, die Strömung zwischen einer Plattenöffnung (14, 15) und dem Wärmeübertragungsbereich (13) zu verhindern.
8. Abstandhalter (100) nach einem der vorstehenden Ansprüche, wobei die Porosität des porösen diagonalen Trägers (103) durch diagonale Abstandhalterströmungswege (103A) gewährleistet ist, die zwischen diagonalen Abstandhalterträgern (103B) ausgebildet sind, die dazu eingerichtet sind, die zwei benachbarten Wärmeübertragungsplatten (11) zu berühren.
9. Abstandhalter (100) nach Anspruch 8, wobei der poröse diagonale Träger (103) aus zwei miteinander verbundenen konzentrischen Halbkreisteilen ausgebildet ist, die dazu eingerichtet sind, in einem diagonalen Bereich positioniert zu werden, wenn sie mit einer Wärmeübertragungsplatte (11) verbunden sind.
10. Abstandhalter (100) nach einem der vorstehenden Ansprüche, wobei der Abstandhalter (100) einen Basisteil (101) mit einem äußeren, dichtungsfreien Basisteilabschnitt (101A) umfasst, wobei der äußere, dichtungsfreie Basisteilabschnitt (101A) mit Poka-Yoke-Vorsprungsmerkmalen (120) ausgebildet ist, die dazu eingerichtet sind, mit Poka-Yoke-Aufnahmemerkmalen (19) zusammenzupassen, die in den Wärmeübertragungsplatten (11) ausgebildet sind.
11. Abstandhalter (100) nach einem der vorstehenden Ansprüche, wobei der Abstandhalter dazu eingerichtet ist, einen Träger für eine Dichtung (12, 112) auszubilden.
12. Abstandhalter (100) nach Anspruch 11, wobei der Abstandhalter (100) einen Basisteil (101) mit einem äußeren, dichtungsfreien Basisteilabschnitt (101A) umfasst, wobei die Dichtung an einer Innenseite des äußeren, dichtungsfreien Abschnitts (101A) positioniert ist.

13. Abstandhalter (100) nach Anspruch 11 oder 12, wobei der Abstandhalter (100) im Wesentlichen steifer und unkomprimierbarer als das Material der Dichtung (102, 102A, 102B) ist.
14. Wärmetauscher (10), der aus einem Stapel strukturierter Wärmeübertragungsplatten (11) ausgebildet ist, die jeweils mit zwei Paar Öffnungen (14, 15) versehen sind, wobei jedes Paar einen Einlass und einen Auslass zu einem ersten Strömungsweg auf einer Seite bzw. einem zweiten Strömungsweg auf der zweiten Seite der Wärmeübertragungsplatte (11) vorsieht, und wobei ein Abstandhalter (100) nach einem der vorstehenden Ansprüche zwischen mindestens zwei angrenzenden, benachbarten Wärmeübertragungsplatten (11) in einem Plattenrandbereich (16) positioniert ist.

### Revendications

1. Espaceur (100) conçu pour être pris en sandwich entre les régions de bord (16) de deux plaques de transfert de chaleur (11) adjacentes d'un échangeur de chaleur à plaques (10), l'espaceur étant formé avec un joint (102, 102A, 102B) dans la surface conçue pour encercler un creux intérieur (105) dudit espaceur (100), et **caractérisé en ce que** l'espaceur (100) est pourvu de sections de support diagonal poreux (103) définissant le côté intérieur d'une ouverture d'espaceur (114, 115) par rapport au creux intérieur (105) et conçu pour être positionné dans une zone diagonale d'une plaque de transfert de chaleur (11) et conçu pour permettre un écoulement passant entre une ouverture de plaque (14, 15) et la zone de transfert de chaleur (13).
2. Espaceur (100) selon la revendication 1, le creux intérieur (105) étant conçu pour que les deux plaques de transfert de chaleur (10) entrent en contact dans une zone de transfert de chaleur (13) définie par lesdites deux plaques de transfert de chaleur (11) reliées.
3. Espaceur (100) selon la revendication 1 ou 2, l'espaceur (100) étant conçu pour empêcher les deux plaques de transfert de chaleur (11) d'entrer en contact dans les régions de bord (16).
4. Espaceur (100) selon la revendication 1, 2 ou 3, l'espaceur (100) comprenant une partie de base (101) avec une section extérieure sans joint de partie de base (101A), la section extérieure sans joint de partie de base (101A) étant pourvue d'ouvertures de barre d'espaceur (118) conçues pour être alignées avec des ouvertures de barre de plaque (18) formées dans une région de bord de plaque (16).
5. Espaceur (100) selon la revendication 4, les ouvertures de barre d'espaceur (118) étant conçues pour que les barres (52) puissent traverser la pile de plaques de transfert de chaleur (11) entre deux plaques de cadre (50).
6. Espaceur (100) selon l'une quelconque des revendications précédentes, l'espaceur (100) comprenant des ouvertures d'espaceur (114, 115) conçues pour être alignées avec les ouvertures de plaque (14, 15).
7. Espaceur (100) selon la revendication 6, l'espaceur (100) étant formé avec une section de joint intérieur de partie de base (101B) définissant le côté intérieur d'une ouverture d'espaceur (114, 115) par rapport au creux intérieur (105) et conçu pour être positionné dans une zone diagonale d'une plaque de transfert de chaleur (11) et conçu pour empêcher un écoulement passant entre une ouverture de plaque (14, 15) et la zone de transfert de chaleur (13).
8. Espaceur (100) selon l'une quelconque des revendications précédentes, la porosité du support diagonal poreux (103) étant assurée par des voies d'écoulement d'espaceur diagonales (103A) formées entre des supports d'espaceur diagonaux (103B) conçus pour entrer en contact avec les deux plaques de transfert de chaleur (11) voisines.
9. Espaceur (100) selon la revendication 8, le support diagonal poreux (103) étant formé de deux parties semi-circulaires concentriques reliées, conçues pour être positionnées dans une zone diagonale lorsqu'elles sont reliées à une plaque de transfert de chaleur (11).
10. Espaceur (100) selon l'une quelconque des revendications précédentes, l'espaceur (100) comprenant une partie de base (101) avec une section extérieure sans joint de partie de base (101A), la section extérieure sans joint de partie de base (101A) étant formée avec des caractéristiques en saillie anti-erreur (120) conçues pour correspondre à des caractéristiques de réception anti-erreur (19) formées dans les plaques de transfert de chaleur (11).
11. Espaceur (100) selon l'une quelconque des revendications précédentes, l'espaceur étant conçu pour former un support pour un joint (12, 112).
12. Espaceur (100) selon la revendication 11, l'espaceur (100) comprenant une partie de base (101) avec une section extérieure sans joint de partie de base (101A), le joint étant positionné à un emplacement intérieur de la section sans joint extérieure (101A).
13. Espaceur (100) selon la revendication 11 ou 12, l'espaceur (100) étant sensiblement plus rigide et in-

compressible que le matériau du joint (102, 102A, 102B).

14. Échangeur de chaleur (10) formé d'une pile de plaques de transfert de chaleur structurées (11) pourvues chacune de deux paires d'ouvertures (14, 15), chaque paire fournissant une entrée et une sortie vers respectivement une première voie d'écoulement d'un côté et une seconde voie d'écoulement du second côté de la plaque de transfert de chaleur (11), et un espaceur (100) selon l'une quelconque des revendications précédentes étant positionné entre au moins deux plaques de transfert de chaleur (11) voisines adjacentes dans une région de bord de plaque (16).

5

10

15

20

25

30

35

40

45

50

55

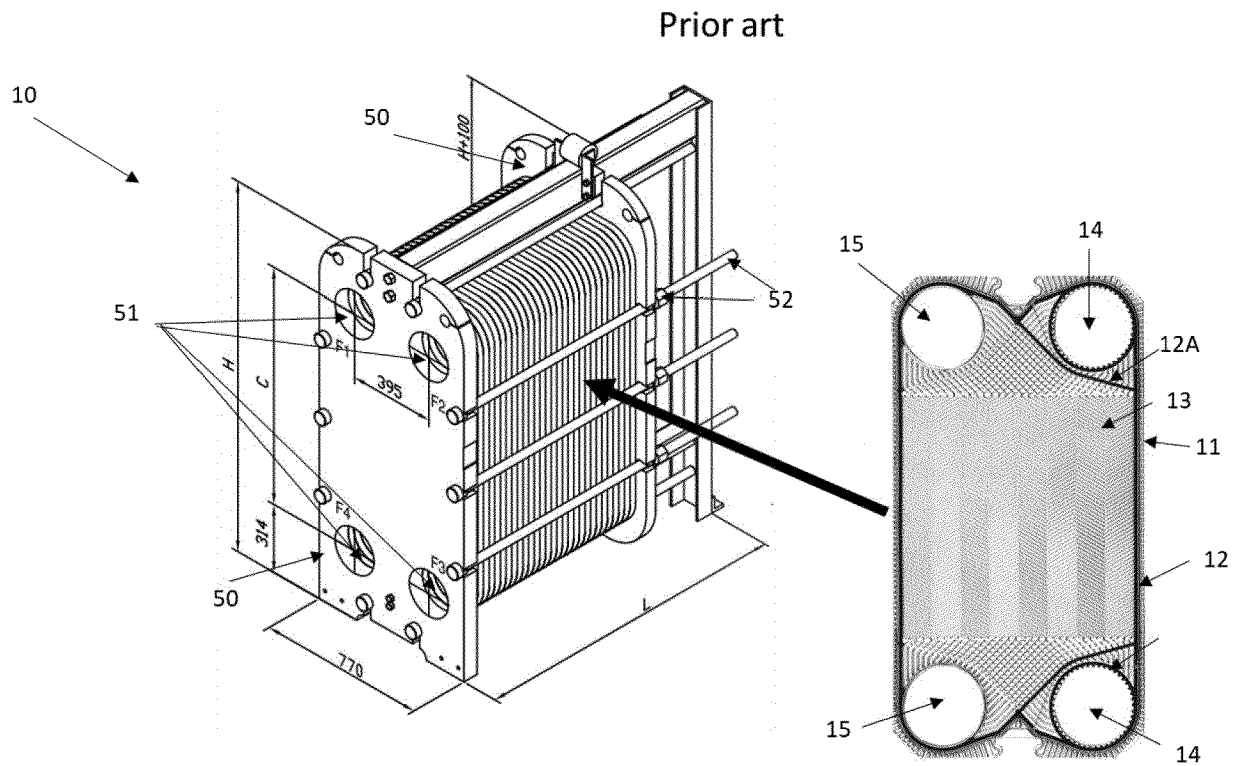
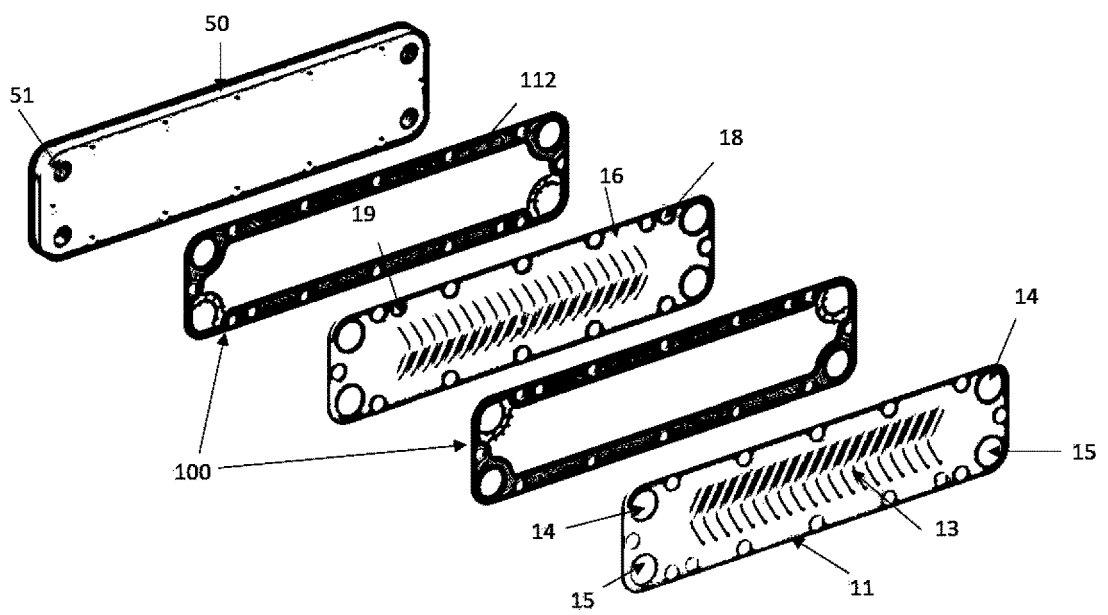

Fig. 1



Exploded State 5/10/00

Fig. 2

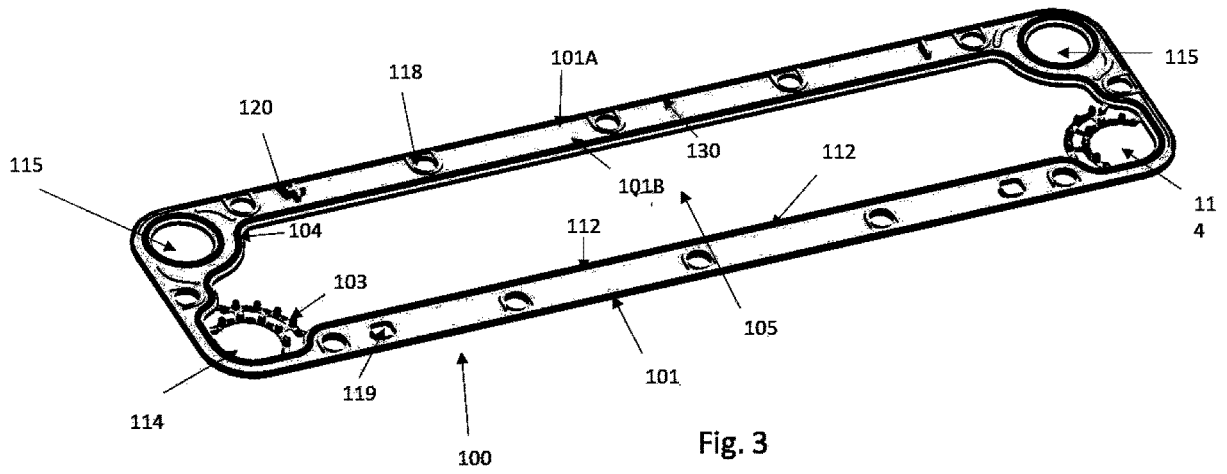

Fig. 3

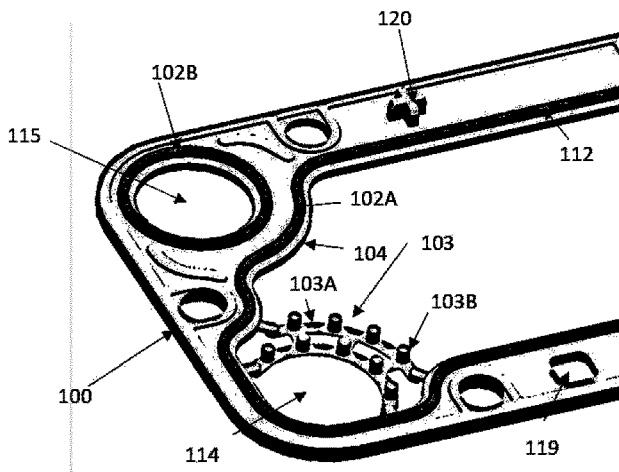

Fig. 4A

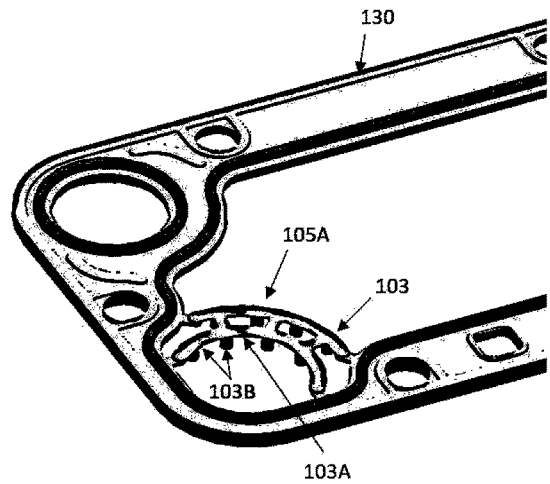
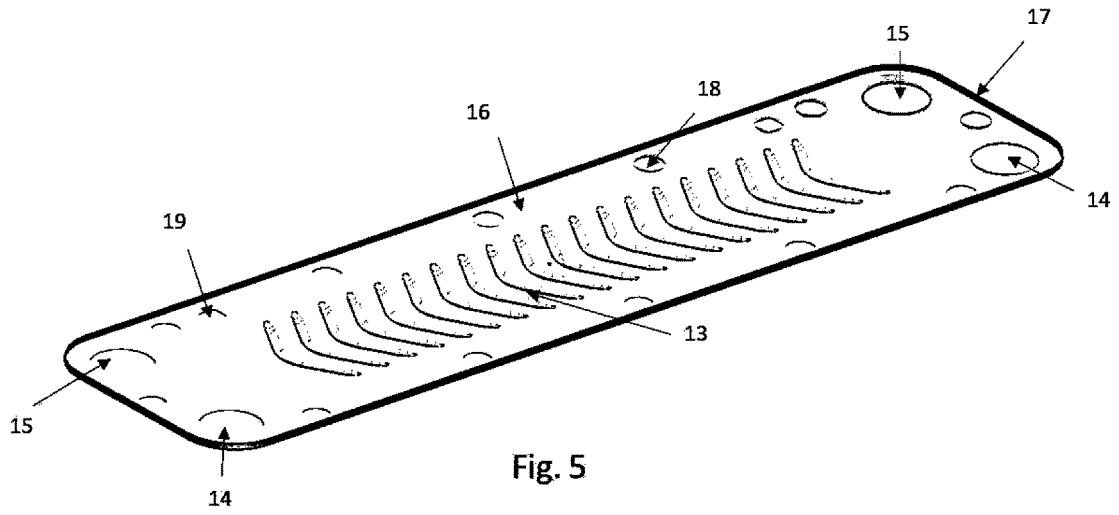
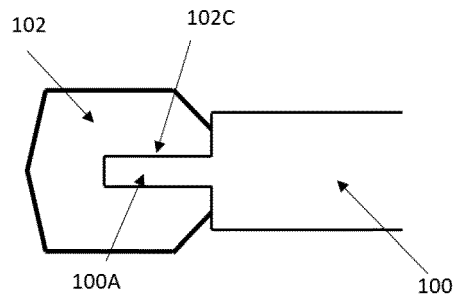
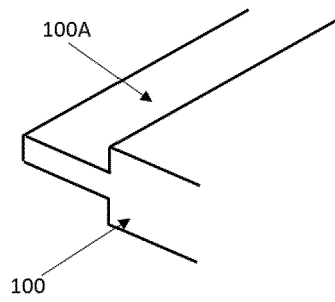

Fig. 4B



1000000



**REFERENCES CITED IN THE DESCRIPTION**

*This list of references cited by the applicant is for the reader's convenience only. It does not form part of the European patent document. Even though great care has been taken in compiling the references, errors or omissions cannot be excluded and the EPO disclaims all liability in this regard.*

**Patent documents cited in the description**

- US 2020271387 A [0003]