

(19)



(11)

**EP 4 059 632 B1**

(12)

**EUROPEAN PATENT SPECIFICATION**

(45) Date of publication and mention of the grant of the patent:  
**27.09.2023 Bulletin 2023/39**

(21) Application number: **22160022.4**

(22) Date of filing: **03.03.2022**

(51) International Patent Classification (IPC):

**B22C 9/06** <sup>(2006.01)</sup>      **B22C 9/12** <sup>(2006.01)</sup>  
**B22C 23/02** <sup>(2006.01)</sup>      **B22D 17/20** <sup>(2006.01)</sup>  
**B22D 17/22** <sup>(2006.01)</sup>      **B05B 7/08** <sup>(2006.01)</sup>  
**B05B 7/12** <sup>(2006.01)</sup>      **B05B 7/24** <sup>(2006.01)</sup>  
**B05B 12/04** <sup>(2006.01)</sup>      **B05B 1/00** <sup>(2006.01)</sup>

(52) Cooperative Patent Classification (CPC):

**B05B 7/0884; B05B 7/1263; B05B 7/2486;**  
**B05B 12/04; B22C 9/065; B22C 9/12; B22C 23/02;**  
**B22D 17/2007; B22D 17/2218; B05B 1/005**

(54) **MOLD LUBRICATING HEAD WITH NOZZLE SETTING SYSTEM**

FORMSCHMIERKOPF MIT DÜSENEINSTELLSYSTEM

TÊTE DE LUBRIFICATION DE MOULE AVEC SYSTÈME DE RÉGLAGE DE BUSE

(84) Designated Contracting States:

**AL AT BE BG CH CY CZ DE DK EE ES FI FR GB**  
**GR HR HU IE IS IT LI LT LU LV MC MK MT NL NO**  
**PL PT RO RS SE SI SK SM TR**

(30) Priority: **15.03.2021 IT 202100006104**

(43) Date of publication of application:  
**21.09.2022 Bulletin 2022/38**

(73) Proprietor: **Paolo Gozio S.r.l.**  
**25035 Ospitaletto (BS) (IT)**

(72) Inventors:

- **GOZIO, Michele**  
**I-25010 San Felice del Benaco, BRESCIA (IT)**

- **MORANDI, Flavio**

**I-25010 San Felice del Benaco, BRESCIA (IT)**

(74) Representative: **Pulieri, Gianluca Antonio**

**Jacobacci & Partners S.p.A.**

**Piazza della Vittoria, 11**

**25122 Brescia (IT)**

(56) References cited:

**EP-A2- 1 350 572      US-A- 4 247 047**  
**US-A- 4 760 961      US-A1- 2007 075 164**  
**US-A1- 2014 263 752**

**EP 4 059 632 B1**

Note: Within nine months of the publication of the mention of the grant of the European patent in the European Patent Bulletin, any person may give notice to the European Patent Office of opposition to that patent, in accordance with the Implementing Regulations. Notice of opposition shall not be deemed to have been filed until the opposition fee has been paid. (Art. 99(1) European Patent Convention).

## Description

### Technical field

**[0001]** The present invention relates to the field of machines and equipment for molding metal materials. In particular, the subject of the present invention is a lubricating head for dispensing a lubricating fluid onto the surface of the mold. The invention is also applicable to the plastics molding industry.

### Background of the invention

**[0002]** As is known, an injection molding machine comprises a fixed plane carrying a first half-mold and a movable plane carrying a second half-mold. Each half-mold, on its inner face, has a plurality of cavities which, coupling with those of the other half-mold, form the imprints corresponding to the pieces to be molded.

**[0003]** At each molding cycle, the movable plane moves closer to the fixed plane until the two half-molds are coupled (closed mold), and, after injecting molten material and waiting a predetermined time interval, the movable plane moves away from the fixed plane, allowing the extraction of the parts (open mold).

**[0004]** When the mold is open, it is necessary to dispense a lubricating fluid (sometimes also a coolant) on the inner faces of the half-molds, the action of which is essential for the correct extraction of the pieces in the next cycle.

**[0005]** To dispense the lubricating fluid, usually composed of a liquid part and air, a lubricating head is used which, placed between the two half-molds when the mold is open, dispenses a plurality of jets, in a manner oriented toward the faces of the half-molds. For this purpose, the lubricating head comprises a plurality of nozzles.

**[0006]** When production requirements change, for example when a mold is changed, and it becomes necessary, for example, to modify the number and the position of the nozzles from which the fluid is to be dispensed, the heads currently known require long set-up times, which are necessary for disassembling the head, modifying the position of the nozzles or changing the configuration thereof, and reassembling the head.

**[0007]** US 2014/263752 A1 describes a sprayer assembly configured to deliver a variety of fluids.

### Object of the invention

**[0008]** It is the object of the present invention to provide a lubricating head for molds equipped with a nozzle setting system that meets the industry requirements and overcomes the drawbacks discussed above with reference to the prior art.

**[0009]** This object is achieved by a lubricating head for molds according to claim 1.

**[0010]** Claim 9 defines a method for setting the apparatus of claim 1. The dependent claims disclose further

advantageous embodiments of the invention.

### Brief description of the drawings

**[0011]** The features and advantages of the lubricating head according to this invention will be apparent from the description below, given by way of non-limiting example according to the figures in the appended drawings, wherein:

- Fig. 1 is a diagram of a molding assembly equipped with a lubricating head;
- Fig. 2 is a diagram of a matrix arrangement of the nozzles of the lubricating head;
- Fig. 3 is a diagram of a region arrangement of the lubricating head nozzles;
- Fig. 4, 4a, 5, 5a, and 6 are diagrams of nozzles of the lubricating head;
- Fig. 7 is a functional diagram of a lubricating apparatus according to an embodiment of the present invention;
- Fig. 8 is a functional diagram of a lubricating apparatus according to another embodiment of the present invention;
- Fig. 9 shows the diagram in Fig. 8 with an example of a setting of the nozzles;
- Fig. 10 is a diagram of a lubricating and/or cooling apparatus according to yet another embodiment of the present invention.

### Detailed description of the invention

**[0012]** Referring to Fig. 1, an assembly for molding metal materials, such as for injection molding, is collectively indicated with 1. The assembly 1 comprises, for example, a press 2 comprising a base 4, a fixed plane 6, and a movable plane 8 supported by the base 4. The fixed plane 6 supports a first half-mold 10 and the movable plane 8 supports a second half-mold 12; the two half-molds comprise a mold. Each half-mold 10, 12 on the respective inner face 10a, 12a has a plurality of cavities which, coupling with the cavities of the other half-mold when the mold is closed, form imprints of the parts to be molded.

**[0013]** The assembly 1 further comprises a lubricator 14 for dispensing jets of lubricating fluid and/or coolant onto the inner faces 10a, 12a of said half-molds 10, 12; the lubricator 14 comprises a column 16 and a lubricating head 18, suspended from the column 16. The lubricator 14 is configured to move the head 18 so as to arrange it between the half-molds 10, 12 when the mold is open (working configuration of the lubricator).

**[0014]** Preferably, the head 18 comprises a head body 18b comprising a regular solid, for example a parallelepiped, having a plurality of head faces 18a, wherein at least one head face 18a, in the working configuration, faces an inner face 10a, 12a of the mold.

**[0015]** The head 18 comprises a plurality of nozzles

20 arranged on at least one of said head faces 18a; each nozzle 20 is adapted to deliver a jet of fluid, typically comprising a liquid portion and air, which together form a nebulized product intended to be deposited on the inner faces 10a, 12a of the half-molds 10, 12.

**[0016]** With reference to Fig. 2, on one of said head faces 18a, the arrangement of the nozzles is assimilable to a nozzle matrix M provided with m rows and n columns. Each position of the matrix M corresponds to a nozzle U<sub>ij</sub>, wherein "i" is the row number (with i=1...m) and "j" is the column number (with j=1...n). For example, the nozzle U<sub>11</sub> is the nozzle that covers the position (1,1) corresponding to the row 1 and the column 1.

**[0017]** In general, however, the arrangement of the nozzles U<sub>ij</sub> on the head face 18a of the head 18 need not be in rows and columns; in other words, the matrix M remains associated with a region of the head face, and the identification of the nozzle U<sub>ij</sub> is carried out with reference to that region. Referring to Fig. 3, for example, on the head face 18a, the region R is identified in which nozzles U<sub>ij</sub> are present. In this context, the nozzle U<sub>11</sub> is the nozzle that covers the position (1,1), corresponding to row 1 and column 1 of the region R.

**[0018]** According to a first embodiment (Fig. 4; nozzle NC), a nozzle 20 has a liquid port 22 for the outlet of the jet of liquid, an air port 24 for the outlet of the jet of pressurized air, a driven liquid valve 22a, a nozzle driving line 22b for driving the liquid valve 22a, a nozzle liquid line 22c for supplying the pressurized liquid, and a nozzle air line 24c for supplying the pressurized air. The nozzle liquid line 22c is suppliable by a nozzle liquid connection 22' and is connectable to the liquid port 22, and the liquid valve 22a, which is normally closed and adapted to switch from the closed to the open configuration, is operational therebetween; the nozzle driving line 22b is supplied by a driving connection nozzle 23 and is connected to the liquid valve 22a to drive it from the closed to the open configuration; the nozzle air line 24c is suppliable by a nozzle air connection 24' and is directly connected to the air port 24.

**[0019]** According to another embodiment (Fig. 5; nozzle NO), the liquid valve 22a' is normally open and adapted to switch from the open configuration to the closed configuration; the nozzle driving line 22b is connected to the liquid valve 22a' to drive it from the open configuration to the closed configuration.

**[0020]** According to yet another embodiment (Fig. 6; nozzle GZ NC), the nozzle 20 comprises, moreover, a driven air valve 24a; the nozzle air line 24c is connectable to the air port 24, and the air valve 24a, which is normally closed and adapted to switch from the closed to the open configuration, is operational therebetween; the nozzle driving line 22b is also connected to the air valve 24a to drive it from the closed to the open configuration.

**[0021]** According to a first embodiment (Fig. 7), the head 18 comprises a head liquid line 32 connected to the nozzle liquid connections 22' of all the nozzles 20 of the head face 18a of the head 18 and a head air line 34

connected to the nozzle air connections 24' of all the nozzles 20 of the head face 18a of the head 18.

**[0022]** A main liquid valve 32a, placed upstream of the head liquid line 32, is adapted to be electrically controlled to open or close the pressurized liquid supply to the head liquid line 32. Similarly, a main air valve 34a, placed upstream of the head air line 34, is adapted to be electrically controlled to open or close the pressurized air supply to the head air line 34.

**[0023]** Further, the head 18 comprises a plurality of first head driving branches 33, wherein each first head driving branch 33 is a driving line connectable to the respective liquid valve 22a of a plurality of nozzles 20, for example, all the nozzles of a predetermined row of a matrix M configuration or a region R configuration.

**[0024]** Further, first head driving valves 33a are provided, wherein each first head driving valve 33a is located upstream of a respective first head driving branch 33 and adapted to be electronically controlled to open or close the supply of driving fluid to said first head driving branch 33.

**[0025]** Further, the head 18 comprises, for each nozzle 20, a driving management valve 35 arranged between each first head driving branch 33 and the liquid valve 22a of the respective nozzle 20, e.g., normally closed and adapted to switch into an opening configuration to place said first head driving branch 33 in communication with the liquid valve 22a to drive it to open.

**[0026]** Further, the head 18 comprises a plurality of second head driving branches 37, wherein each second head driving branch 37 is a driving line connected to the driving management valves 35 of a plurality of nozzles 20, e.g., all the nozzles of a predetermined column of a matrix M configuration or a region R configuration.

**[0027]** In other words, if the nozzles of a predetermined row comprise a first plurality of nozzles and the nozzles of a predetermined column comprise a second plurality of nozzles, said first plurality of nozzles and said second plurality of nozzles have at least one nozzle in common.

**[0028]** Moreover, second head driving valves 33b are provided, wherein each second head driving valve 33b is placed upstream of a respective second head driving branch 37 and adapted to be electronically controlled to open or close the driving fluid supply to said second head driving branch 37.

**[0029]** In normal use of the head 18 in said embodiment, starting with an initial configuration wherein the main liquid valve 32a is closed, the air main valve 34a is closed, all first head driving valves 33a are closed, and all second head driving valves 33b are closed, the main air valve 34a may be opened, causing air to be blown from the air ports 24 of all the nozzles 20, which is sometimes desired for cleaning the half-mold.

**[0030]** Alternatively or subsequently, the main liquid valve 32a may be opened to put pressure on the head liquid line 32; however, as long as there is no driving of the liquid valves 22a of the nozzles 20, no dispensing of the liquid will occur. The opening of a predetermined first

head driving valve 33a allows for pressurizing and supplying driving fluid to a respective first head driving branch 33, which is intercepted, upstream of the respective nozzles 20, by the respective driving management valves 35, so that, as long as there is no driving of the driving management valves 35, there is no opening of the respective liquid valves 22a. Finally, the opening of a predetermined second head driving valve 33b allows for the respective driving management valves 35 to be driven to open, and this allows for the liquid valves 22a of the nozzles 20 supplied by the first head driving branch 33 corresponding to the first open head driving valve 33a to open.

**[0031]** In other words, such a system allows liquid to be dispensed from a predetermined nozzle U<sub>ij</sub> by opening the i-th first head driving valve 33a and the j-th second head driving valve 33b. As a result, by combining the openings of the first head driving valves 33a and the second head driving valves 33b, it is possible to select individually the nozzles of an entire matrix M or region R to be enabled for liquid dispensing according to the requirements.

**[0032]** In still other words, the head setting method comprises:

- a) actuating the first head driving valve 33a for fluidly selecting the first plurality of nozzles (20);
- b) actuating the second head driving valve 33b for fluidly selecting the second plurality of nozzles (20);
- c) said predetermined common nozzle being thus identified and activated for dispensing a lubricating and/or cooling fluid.

**[0033]** The nozzles 20 mentioned above are of the nozzle type NC; according to a variant, said nozzles are of the nozzle type NO.

**[0034]** According to yet another embodiment (Fig. 8), each nozzle 20 comprises an air valve 24a (nozzle GZ NO, Fig. 6), which is connectable to the first head driving branch 33 by means of the respective driving management valve 35, which in turn may be drivable by the second head driving branch 37.

**[0035]** This allows the jet of air to be controlled by the air port 24 of the nozzle 20, together with the jet of liquid. Obviously, by keeping the main liquid valve 32a closed and opening the main air valve 34a, air-only blowing may be performed on the mold, using the individually selected nozzles.

**[0036]** In general, in all of the aforesaid embodiments, to some nozzles 20 or to the nozzle seats of the head to which said nozzles are applied, if not used, special caps are applied that prevent the outflow of liquid and air, even though they are connected to the supply lines.

**[0037]** The driving management valve 35 is a driven check valve, suitable for maintaining pressure in the driving line to which it is connected downstream, even when the driving fluid supply from the respective first head driving valve 33a ceases, and when the command coming

from the respective second head driving valve 33b to drive to open ceases, since said downstream driving line is not connected to the drain.

**[0038]** This allows a head 18 to be quickly set up for lubrication and/or cooling of a mold by means of successive activations of the first head driving valves 33a and of the second head driving valves 33b.

**[0039]** For example, with reference to Fig. 9, it is assumed that the nozzles U<sub>11</sub>, U<sub>13</sub>, U<sub>22</sub>, U<sub>24</sub>, U<sub>31</sub>, U<sub>33</sub>, U<sub>34</sub>, U<sub>42</sub>, and U<sub>43</sub> must be activated. While the main liquid valve 32a is closed, the main air valve 34a is closed, and the main driving line 39 is pressurized:

- the 1st second head driving valve 33b, the 1st first head driving valve 33a, and the 3rd first head driving valve 33a are activated; when these valves are then deactivated, the driving of the nozzles U<sub>11</sub> and U<sub>31</sub> remains active and pressurized by virtue of their respective driving management valves 35;
- the 2nd second head driving valve 33b, the 2nd first head driving valve 33a and the 4th first head driving valve 33a are activated; when said valves are then deactivated, the driving of the nozzles U<sub>22</sub> and U<sub>24</sub> remains active and pressurized by virtue of their respective driving management valves 35;
- the 3rd second head driving valve 33b, the 1st first head driving valve 33a, the 3rd first head driving valve 33a, and the 4th first head driving valve 33a are activated; when these valves are then deactivated, the driving of the nozzles U<sub>31</sub>, U<sub>33</sub> and U<sub>34</sub> remains active and pressurized by virtue of their respective driving management valves 35;
- the 4th second head driving valve 33b, the 2nd first head driving valve 33a, and the 3rd first head driving valve 33a are activated; when these valves are then deactivated, the driving of the nozzles U<sub>42</sub> and U<sub>43</sub> remains active and pressurized by virtue of their respective driving management valves 35.

**[0040]** By then operating the main liquid valve 32a and the main air valve 34a at the beginning of each molding cycle, it is possible to spray the surface of the mold with a nebulized jet.

**[0041]** Ultimately, the setting method of the present invention is executable by a head 18

- wherein said head 18 comprises:

- a) a first plurality of nozzles 20 fluidly selectable for activation by actuating a first head driving valve 33a;
- b) a second plurality of nozzles 20 fluidly selectable for activation by actuating a second head driving valve 33b, wherein said first plurality of nozzles and said second plurality of nozzles have at least one predetermined nozzle in common;

- and wherein the method comprises:

- a) actuating the first head driving valve 33a for fluidly selecting the first plurality of nozzles 20;
- b) actuating the second head driving valve 33b for fluidly selecting the second plurality of nozzles 20;
- c) said predetermined nozzle in common being thus identified and activated for dispensing a lubricating and/or cooling fluid.

**[0042]** According to an embodiment of the head, using a nozzle NO (Fig. 4), an air valve 24" is placed upstream of the nozzle 20 (Fig. 4a); similarly, using a nozzle NO (Fig. 5), an air valve 24" is placed upstream of the nozzle 20 (Fig. 5a).

**[0043]** A lubricating apparatus (Fig. 10) comprises the lubricator 14 described above, valve means 90 comprising the first head driving valves 33a, the second head driving valves 33b, the main liquid valve 32a and the main air valve 34a, and a management device 100, which is operationally connected to the lubricator and valve means 90 for managing lubricator operations.

**[0044]** The management device comprises electronic management means 105 adapted to be configured or programmed, for example by software, for the programmed actuation of the main liquid valve 32a, the main air valve 34a, the first head driving valves 33a and the second head driving valves 33b. For example, said electronic management means comprise a microchip or a dedicated circuit board.

**[0045]** Preferably, moreover, the management device 100 comprises storage means 110 adapted to store data identifying a predetermined mold and setting data for identifying the nozzles to be activated for lubricating or cooling said predetermined mold.

**[0046]** The storage means 110 are operationally connected with the electronic management means and, preferably, with the lubricator 14, so that, when a predetermined mold is reused, the nozzles identified by the setting data are automatically activated by the electronic management means 105.

**[0047]** According to another aspect of the invention, the management device 100 comprises temperature detection means 115 adapted to detect the temperature at a plurality of discrete locations identified on the face of a half-mold by defining temperature data comprising a temperature matrix T wherein each discrete location on the face of the half-mold corresponds to the detected temperature.

**[0048]** The management device 100 further comprises processing means 120 adapted to process the temperature matrix T and generate nozzle setting data to define which nozzles to activate in order to achieve optimal lubrication or cooling of the half-mold.

**[0049]** The processing means 120 are operationally connected to the electronic management means 105 to activate the nozzles identified by the setting data during

the lubrication and/or cooling cycles performed between molding cycles.

**[0050]** Innovatively, the head with a nozzle setting system according to the present invention meets the needs of the industry and overcomes the drawbacks discussed above with reference to the prior art.

**[0051]** Advantageously, for example, the head allows, when setting the nozzles, to work remotely, eliminating the need for the operator to physically intervene on the head.

**[0052]** Advantageously, moreover, the head allows for nozzle setting operations to be performed quickly and the preferred setting for a predetermined mold to be stored so that it may be recalled in subsequent operations.

**[0053]** According to another advantageous aspect, the head according to the invention allows for predetermined and automatic nozzle cleaning cycles to be carried out.

**[0054]** According to yet another advantageous aspect, the head according to the invention allows for working together with a thermo-detection system operating on the mold, to coordinate and optimize the lubrication and cooling of the molds.

**[0055]** It is clear that a person skilled in the art, in order to satisfy current needs, could make modifications to the head described above, said modifications all being contained within the scope of protection defined in the following claims.

## Claims

1. A lubricating and/or cooling apparatus for a molding machine for metal materials, comprising:

A) a lubricator (14) comprising a lubricating head (18) comprising:

- i) a head body (18b) having a head face (18a);
- ii) a plurality of nozzles (20), wherein each nozzle (20) is applicable to the body face (18a) and has a liquid port (22) and an air port (24), a drivable liquid valve (22a), a nozzle driving line (22b) for driving the liquid valve (22a), a nozzle liquid line (22c) for supplying the pressurized liquid and a nozzle air line (24c) for supplying the pressurized air, wherein the liquid valve (22a) is operational between the nozzle liquid line (22c) and the liquid port (22), the nozzle driving line (22b) is connected to the liquid valve (22) to drive it, and the nozzle air line (24c) is connectable to the air port (24);
- iii) a head liquid line (32) connected to the nozzles (20) for supplying the respective liquid ports (22), a head air line (34) connected to the nozzles (20) for supplying the respec-

tive air ports (24);  
 iv) a plurality of first head driving branches (33), wherein each first head driving branch (33) is a driving line connectable to the respective liquid valve (22a) of a first plurality of nozzles (20);  
 v) for each nozzle (20), a drivable driving management valve (35), operational between each first head driving branch (33) and the liquid valve (22a) of the respective nozzle (20);  
 vi) a plurality of second head driving branches (37), wherein each second head driving branch (37) is a driving line connected to the driving management valves (35) of a second plurality of nozzles (20), said first plurality of nozzles and said second plurality of nozzles having at least one nozzle in common;

B) valve means (90) comprising:

i) a plurality of first head driving valves (33a), wherein each first head driving valve (33a) is placed upstream of a respective first head driving branch (33) and is electronically controllable for supplying the driving fluid to said respective first head driving branch (33);  
 ii) a plurality of second head driving valves (33b), wherein each second head driving valve (33b) is placed upstream of a respective second head driving branch (37) and is electronically controllable for supplying the driving fluid to said second head driving branch (37);  
 iii) a main liquid valve (32a) placed upstream of the head liquid line (32) and electrically controllable for opening or closing the supply of pressurized liquid to the head liquid line (32), and a main air valve (34a) placed upstream of the head air line (34) and electrically controllable for opening or closing the supply of pressurized air to the head air line (34).

2. An apparatus according to claim 1, wherein each nozzle (20) comprises a drivable air valve (24a), operational between the nozzle air line (24c) and the air port (24), wherein the nozzle driving line (22b) is also connected to the air valve (24a) to drive it.
3. An apparatus according to claim 1, comprising, for each nozzle (20), a drivable air valve (24a), outside the respective nozzle (20), operational between the nozzle air line (24c) and the air port (24), wherein the nozzle driving line (22b) is also connected to the air valve (24a) to drive it.

4. An apparatus according to any one of the preceding claims, wherein the driving management valve (35) is a driven check valve.
5. An apparatus according to any one of the preceding claims, comprising a management device (100) for managing the lubrication and/or cooling operations.
6. An apparatus according to claim 5, wherein the management device (100) comprises electronic management means (105) adapted to be configured or programmed for the programmed actuation of the main liquid valve (32a), the main air valve (34a), the first head driving valves (33a) and the second head driving valves (33b) as a function of setting data defining the nozzles to be activated.
7. An apparatus according to claim 6, wherein the management device (100) comprises storage means (110) adapted to store identification data of a predetermined mold and setting data of the nozzles corresponding to said predetermined mold for identifying the nozzles to be activated for said predetermined mold.
8. An apparatus according to claim 5 or 6, wherein the management device (100) comprises:
  - temperature detection means (115) adapted to detect the temperature of a plurality of predetermined discrete positions on the face of a half-mold, defining temperature data consisting of a temperature matrix (T), wherein the detected temperature corresponds to each discrete position of the face of the half-mold; and
  - processing means (120) adapted to process the temperature matrix (T) and generate setting data of the nozzles for defining the nozzles to be activated in order to obtain an optimum lubrication and/or cooling of the half-mold as a function of the detected temperatures.
9. A method for setting a lubrication and/or cooling apparatus for a molding machine for metal materials,
  - said apparatus according to any of the preceding claims;
  - wherein the method comprises:
    - a) actuating the first head driving valve (33a) for fluidly selecting the first plurality of nozzles (20);
    - b) actuating the second head driving valve (33b) for fluidly selecting the second plurality of nozzles (20);
    - c) said predetermined nozzle in common being thus identified and activated for supplying a lubricating and/or cooling fluid.

## Patentansprüche

1. Schmier- und/oder Kühlvorrichtung für eine Formgebungsmaschine für metallische Materialien, umfassend:

A) einen Schmierapparat (14), umfassend einen Schmierkopf (18), umfassend:

- i) einen Kopfkörper (18b), welcher eine Kopffläche (18a) aufweist;
- ii) eine Mehrzahl von Düsen (20), wobei jede Düse (20) auf die Kopffläche (18a) anwendbar ist und einen Flüssigkeitsanschluss (22) und einen Luftanschluss (24), ein antreibbares Flüssigkeitsventil (22a), eine Düsenantriebsleitung (22b) zum Antreiben des Flüssigkeitsventils (22a), eine Düsenflüssigkeitsleitung (22c) zum Bereitstellen der Druckflüssigkeit und eine Düsenluftleitung (24c) zum Bereitstellen der Druckluft aufweist, wobei das Flüssigkeitsventil (22a) zwischen der Düsenflüssigkeitsleitung (22c) und dem Flüssigkeitsanschluss (22) einsatzfähig ist, die Düsenantriebsleitung (22b) mit dem Flüssigkeitsventil (22) verbunden ist, um es anzutreiben, und die Düsenluftleitung (24c) mit dem Luftanschluss (24) verbindbar ist;
- iii) eine Kopfflüssigkeitsleitung (32), welche mit den Düsen (20) zum Bereitstellen der jeweiligen Flüssigkeitsanschlüsse (22) verbunden ist, eine Kopfluftleitung (34), welche mit den Düsen (20) zum Bereitstellen der jeweiligen Luftanschlüsse (24) verbunden ist;
- iv) eine Mehrzahl erster Kopfantriebsabzweigungen (33), wobei jede erste Kopfantriebsabzweigung (33) eine Antriebsleitung ist, welche mit dem jeweiligen Flüssigkeitsventil (22a) einer ersten Mehrzahl von Düsen (20) verbindbar ist;
- v) für jede Düse (20), ein antreibbares Antriebsverwaltungsventil (35), welches zwischen jeder ersten Kopfantriebsabzweigung (33) und dem Flüssigkeitsventil (22a) der jeweiligen Düse (20) einsatzfähig ist;
- vi) eine Mehrzahl zweiter Kopfantriebsabzweigungen (37), wobei jede zweite Kopfantriebsabzweigung (37) eine Antriebsleitung ist, welche mit den Antriebsverwaltungsventilen (35) einer zweiten Mehrzahl von Düsen (20) verbunden ist, wobei die erste Mehrzahl von Düsen und die zweite Mehrzahl von Düsen wenigstens eine gemeinsame Düse aufweisen;

B) Düsenmittel (90), umfassend:

- i) eine Mehrzahl erster Kopfantriebsventile (33a), wobei jedes erste Kopfantriebsventil (33a) vorgelagert zu einer jeweiligen ersten Kopfantriebsabzweigung (33) angeordnet ist und zum Bereitstellen des Antriebsfluids an die jeweilige erste Kopfantriebsabzweigung (33) elektronisch steuerbar ist;
  - ii) eine Mehrzahl zweiter Kopfantriebsventile (33b), wobei jedes zweite Kopfantriebsventil (33b) vorgelagert zu einer jeweiligen zweiten Kopfantriebsabzweigung (37) angeordnet ist und zum Bereitstellen des Antriebsfluids an die jeweilige zweite Kopfantriebsabzweigung (37) elektronisch steuerbar ist;
  - iii) ein Hauptflüssigkeitsventil (32a), welches vorgelagert zu der Kopfflüssigkeitsleitung (32) angeordnet ist und zum Öffnen oder Schließen der Bereitstellung von Druckflüssigkeit an der Kopfflüssigkeitsleitung (32) elektronisch steuerbar ist, und ein Hauptluftventil (34a), welches vorgelagert zu der Kopfluftleitung (34) angeordnet ist und zum Öffnen oder Schließen der Bereitstellung von Druckluft an der Kopfluftleitung (34) elektronisch steuerbar ist.
2. Vorrichtung nach Anspruch 1, wobei jede Düse (20) ein antreibbares Luftventil (24a) umfasst, welches zwischen der Düsenluftleitung (24c) und dem Luftanschluss (24) einsatzfähig ist, wobei die Düsenantriebsleitung (22b) ebenfalls mit dem Luftventil (24a) verbunden ist, um es anzutreiben.
3. Vorrichtung nach Anspruch 1, umfassend, für jede Düse (20), ein antreibbares Luftventil (24a) außerhalb der jeweiligen Düse (20), welches zwischen der Düsenluftleitung (24c) und dem Luftanschluss (24) einsatzfähig ist, wobei die Düsenantriebsleitung (22b) ebenfalls mit dem Luftventil (24a) verbunden ist, um es anzutreiben.
4. Vorrichtung nach einem der vorhergehenden Ansprüche, wobei das Antriebsverwaltungsventil (35) ein angetriebenes Rückschlagventil ist.
5. Vorrichtung nach einem der vorhergehenden Ansprüche, umfassend eine Verwaltungseinrichtung (100) zum Verwalten der Schmier- und/oder Kühlvorgänge.
6. Vorrichtung nach Anspruch 5, wobei die Verwaltungseinrichtung (100) elektronische Verwaltungsmittel (105) umfasst, welche dazu eingerichtet sind, für die programmierte Betätigung des Hauptflüssigkeitsventils (32a), des Hauptluftventils (34a), der ersten Kopfantriebsventile (33a) und der zweiten Kopfantriebsventile (33b) als eine Funktion von Ein-

stellendaten, welche die zu aktivierenden Düsen definieren, konfiguriert oder programmiert zu sein.

7. Vorrichtung nach Anspruch 6, wobei die Verwaltungseinrichtung (100) Speichermittel (110) umfasst, welche dazu eingerichtet sind, Identifikationsdaten einer vorbestimmten Form zu speichern und Daten der Düsen für die vorbestimmte Form einzustellen, welche zum Identifizieren der zu aktivierenden Düsen der vorbestimmten Form entsprechen. 5 10
8. Vorrichtung nach Anspruch 5 oder 6, wobei die Verwaltungseinrichtung (100) umfasst:
- Temperaturdetektionsmittel (115), welche dazu eingerichtet sind, die Temperatur einer Mehrzahl vorbestimmter diskreter Positionen an der Fläche einer Halbform zu detektieren, welche eine Temperaturmatrix (T) beinhaltende Temperaturdaten definiert, wobei die detektierte Temperatur jeder diskreten Position der Fläche der Halbform entspricht; und 15 20
  - Verarbeitungsmittel (120), welche dazu eingerichtet sind, die Temperaturmatrix (T) zu verarbeiten und zum Definieren der zu aktivierenden Düsen Einstelldaten der Düsen zu erzeugen, um ein optimales Schmieren und/oder Kühlen der Halbform als eine Funktion der detektierten Temperaturen zu erhalten. 25 30
9. Verfahren zum Einstellen einer Schmier- und/oder Kühlvorrichtung für eine Formgebungsmaschine für metallische Materialien,
- mit der Vorrichtung nach einem der vorhergehenden Ansprüche; 35
  - wobei das Verfahren umfasst:
    - a) Betätigen des ersten Kopfantriebsventils (33a) zum fluidischen Auswählen der ersten Mehrzahl von Düsen (20); 40
    - b) Betätigen des zweiten Kopfantriebsventils (33b) zum fluidischen Auswählen der zweiten Mehrzahl von Düsen (20);
    - c) wodurch die vorbestimmte gemeinsame Düse zum Bereitstellen eines Schmier- und/oder Kühlfluids identifiziert und aktiviert wird. 45

## Revendications

1. Appareil de lubrification et/ou de refroidissement pour une machine de moulage pour des matériaux métalliques, comprenant : 55
- A) un lubrificateur (14) comprenant une tête de lubrification (18) comportant :

- i) un corps de tête (18b) ayant une face de tête (18a) ;
- ii) une pluralité de buses (20), dans lequel chaque buse (20) peut être appliquée à la face de corps (18a) et comprend un orifice de liquide (22) et un orifice d'air (24), une soupape à liquide (22a) pouvant être commandée, une ligne de commande de buse (22b) pour commander la soupape à liquide (22a), une ligne de liquide de buse (22c) pour amener le liquide sous pression et une ligne d'air de buse (24c) pour amener l'air sous pression, dans lequel la soupape à liquide (22a) est opérationnelle entre la ligne de liquide de buse (22c) et l'orifice de liquide (22), la ligne de commande de buse (22b) est reliée à la soupape à liquide (22) pour la commander, et la ligne d'air de buse (24c) peut être reliée à l'orifice d'air (24) ;
- iii) une ligne de liquide de tête (32) reliée aux buses (20) pour alimenter les orifices de liquide (22) respectifs, une ligne d'air de tête (34) reliée aux buses (20) pour alimenter les orifices d'air (24) respectifs ;
- iv) une pluralité de premiers branchements de commande de tête (33), dans lequel chaque premier branchement de commande de tête (33) est une ligne de commande pouvant être reliée à la soupape à liquide (22a) respective d'une première pluralité de buses (20) ;
- v) pour chaque buse (20), une soupape de gestion de commande (35) pouvant être commandée, opérationnelle entre chaque premier branchement de commande de tête (33) et la soupape à liquide (22a) de la buse (20) respective ;
- vi) une pluralité de seconds branchements de commande de tête (37), dans lequel chaque second branchement de commande de tête (37) est une ligne de commande reliée aux soupapes de gestion de commande (35) d'une seconde pluralité de buses (20), ladite première pluralité de buses et ladite seconde pluralité de buses comprenant au moins une buse en commun ;

B) des moyens formant soupape (90) comprenant :

- i) une pluralité de premières soupapes de commande de tête (33a), dans lequel chaque première soupape de commande de tête (33a) est placée en amont d'un premier branchement de commande de tête (33) respectif et peut être commandée électriquement pour amener le fluide de commande audit premier branchement de com-

- mande de tête (33) respectif ;  
 ii) une pluralité de secondes soupapes de commande de tête (33b), dans lequel chaque seconde soupape de commande de tête (33b) est placée en amont d'un second branchement de commande de tête (37) respectif et peut être commandée électriquement pour amener le fluide de commande audit second branchement de commande de tête (37) ;  
 iii) une soupape à liquide principale (32a) placée en amont de la ligne de liquide de tête (32) et pouvant être commandée électriquement pour ouvrir ou fermer l'amenée de liquide sous pression à la ligne de liquide de tête (32), et une soupape d'air principale (34a) placée en amont de la ligne d'air de tête (34) et pouvant être commandée électriquement pour ouvrir ou fermer l'amenée d'air sous pression à la ligne d'air de tête (34).
2. Appareil selon la revendication 1, dans lequel chaque buse (20) comprend une soupape à air (24a) pouvant être commandée, opérationnelle entre la ligne d'air de buse (24c) et l'orifice d'air (24), dans lequel la ligne de commande de buse (22b) est également reliée à la soupape à air (24a) pour la commander.
3. Appareil selon la revendication 1, comprenant, pour chaque buse (20), une soupape à air (24a) pouvant être commandée, à l'extérieur de la buse (20) respective, opérationnelle entre la ligne d'air de buse (24c) et l'orifice d'air (24), dans lequel la ligne de commande de buse (22b) est également reliée à la soupape à air (24a) pour la commander.
4. Appareil selon l'une quelconque des revendications précédentes, dans lequel la soupape de gestion de commande (35) est un clapet anti-retour commandé.
5. Appareil selon l'une quelconque des revendications précédentes, comprenant un dispositif de gestion (100) pour gérer les opérations de lubrification et/ou de refroidissement.
6. Appareil selon la revendication 5, dans lequel le dispositif de gestion (100) comprend des moyens de gestion électroniques (105) adaptés pour être configurés ou programmés pour l'actionnement programmé de la soupape à liquide principale (32a), de la soupape à air principale (34a), des premières soupapes de commande de tête (33a) et des secondes soupapes de commande de tête (33b) en fonction de données de réglage définissant les buses à activer.
7. Appareil selon la revendication 6, dans lequel le dispositif de gestion (100) comprend des moyens de stockage (110) adaptés pour stocker des données d'identification d'un moule prédéterminé et des données de réglage des buses correspondant audit moule prédéterminé pour identifier les buses à activer pour ledit moule prédéterminé.
8. Appareil selon la revendication 5 ou 6, dans lequel le dispositif de gestion (100) comprend :
- des moyens de détection de température (115) adaptés pour détecter la température d'une pluralité de positions discrètes prédéterminées sur la face d'un demi-moule, définissant des données de température consistant en une matrice de température (T), dans lequel la température détectée correspond à chaque position discrète de la face du demi-moule ; et
  - des moyens de traitement (120) adaptés pour traiter la matrice de température (T) et générer des données de réglage des buses pour définir les buses à activer afin d'obtenir une lubrification et/ou un refroidissement optimaux du demi-moule en fonction des températures détectées.
9. Procédé pour régler un appareil de lubrification et/ou de refroidissement pour une machine de moulage pour des matériaux métalliques,
- ledit appareil selon l'une quelconque des revendications précédentes ;
  - dans lequel le procédé comprend :
    - a) l'actionnement de la première soupape de commande de tête (33a) pour sélectionner fluidiquement la première pluralité de buses (20) ;
    - b) l'actionnement de la seconde soupape de commande de tête (33b) pour sélectionner fluidiquement la seconde pluralité de buses (20) ;
    - c) ladite buse prédéterminée en commun étant ainsi identifiée et activée pour amener un fluide de lubrification et/ou de refroidissement.

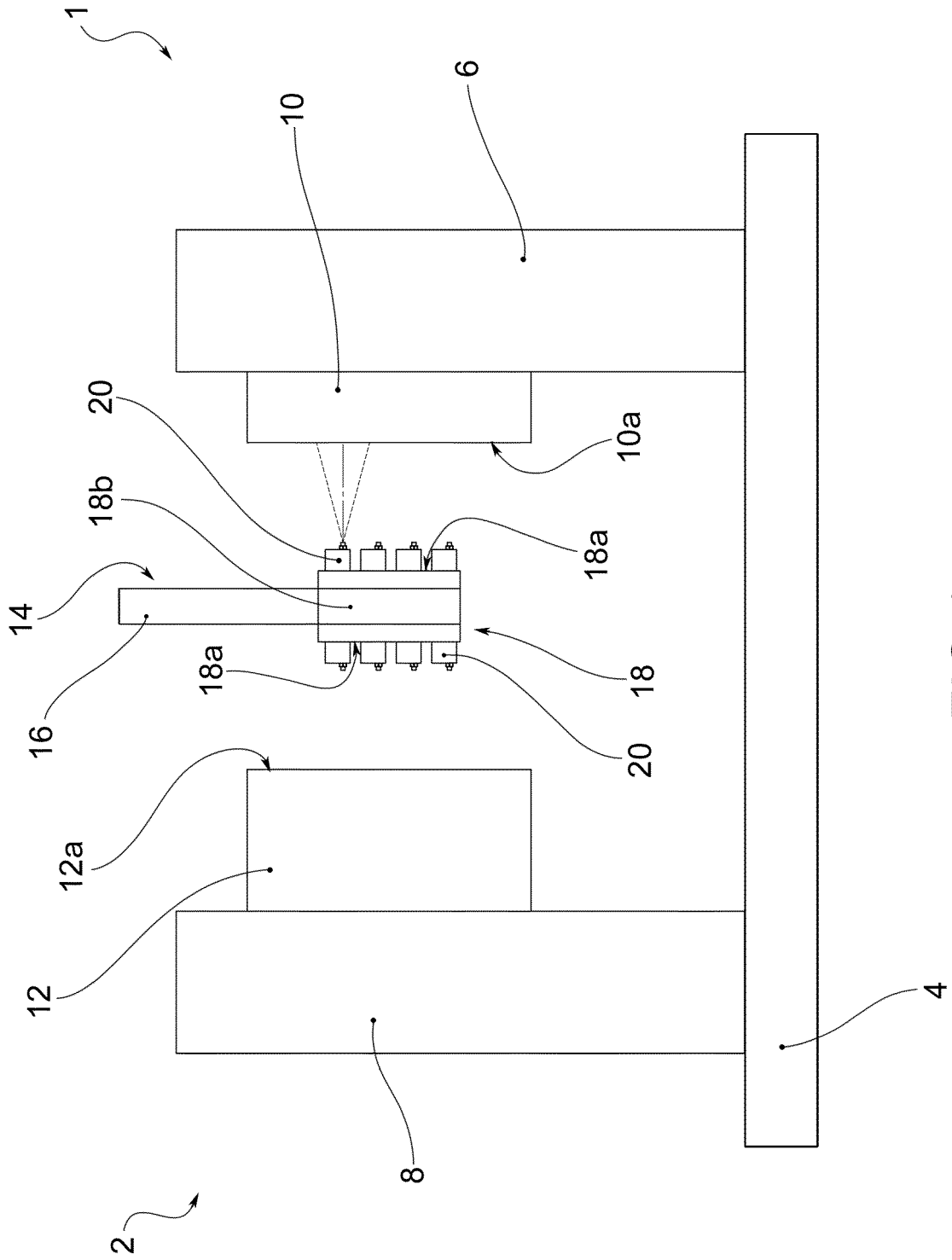

FIG.1

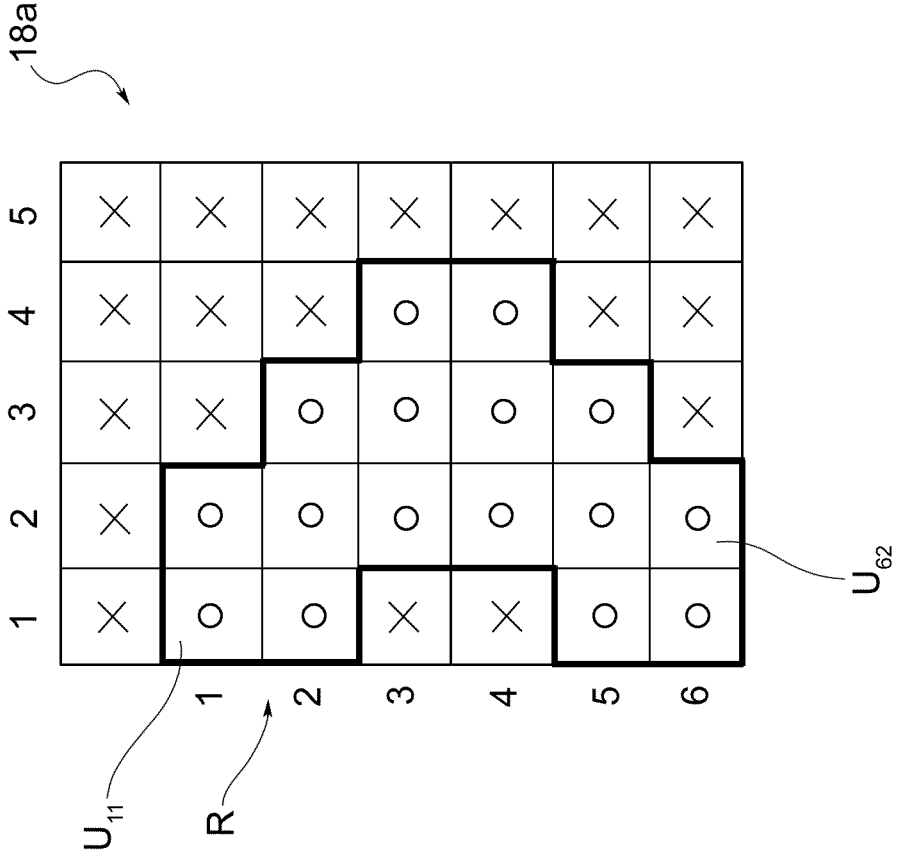

FIG.3

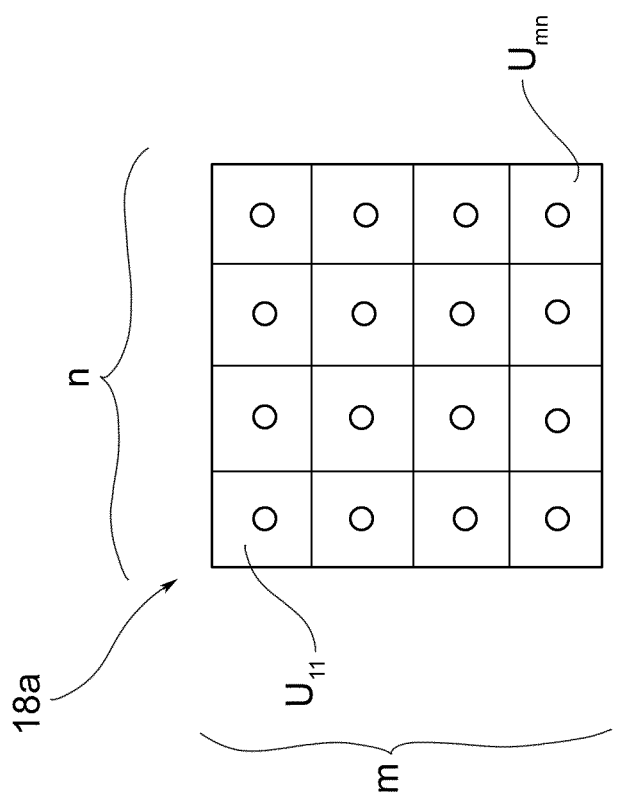

FIG.2

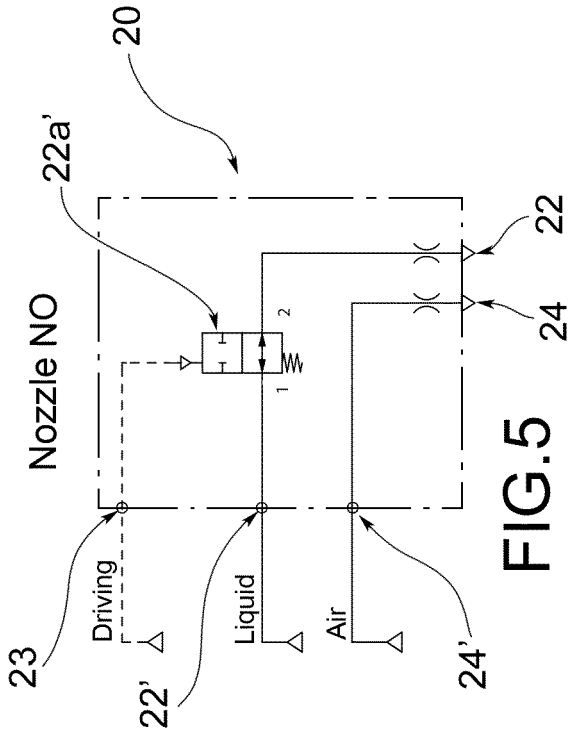

FIG. 5

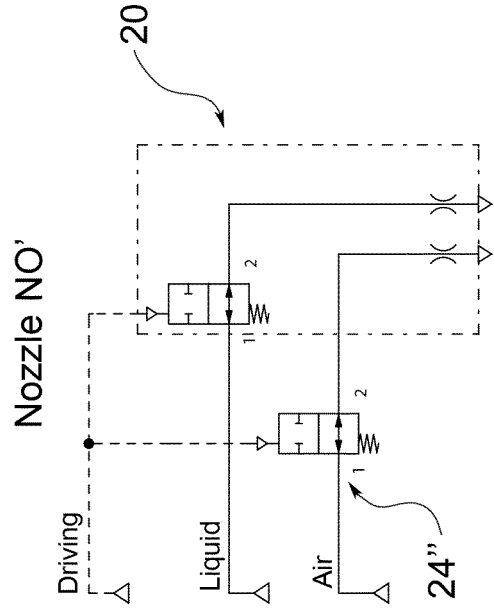

FIG. 5a

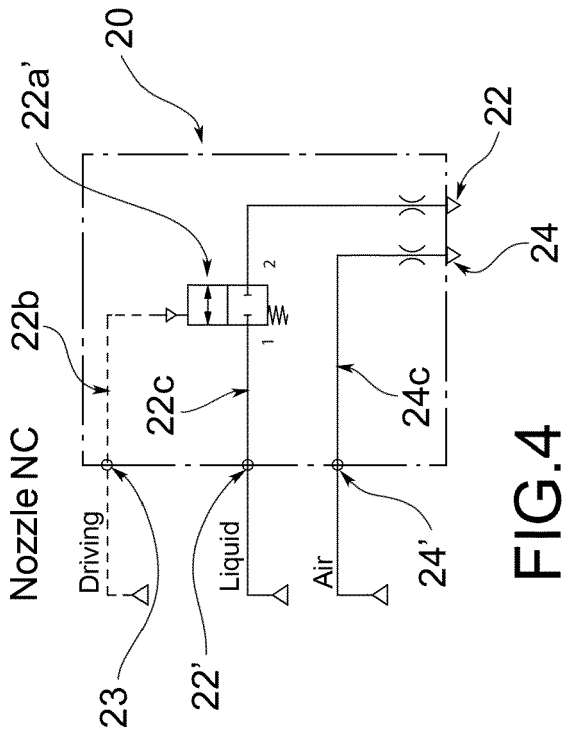

FIG. 4

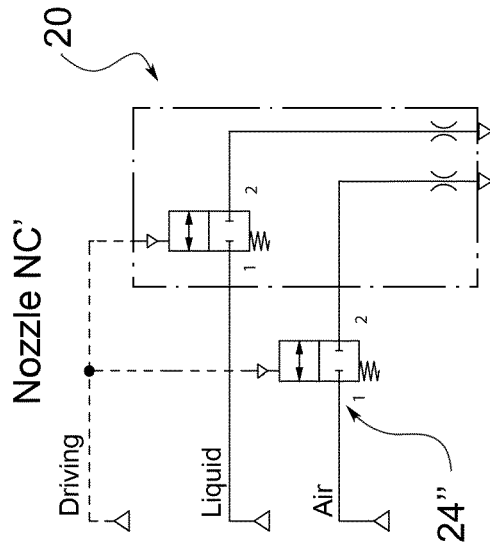

FIG. 4a



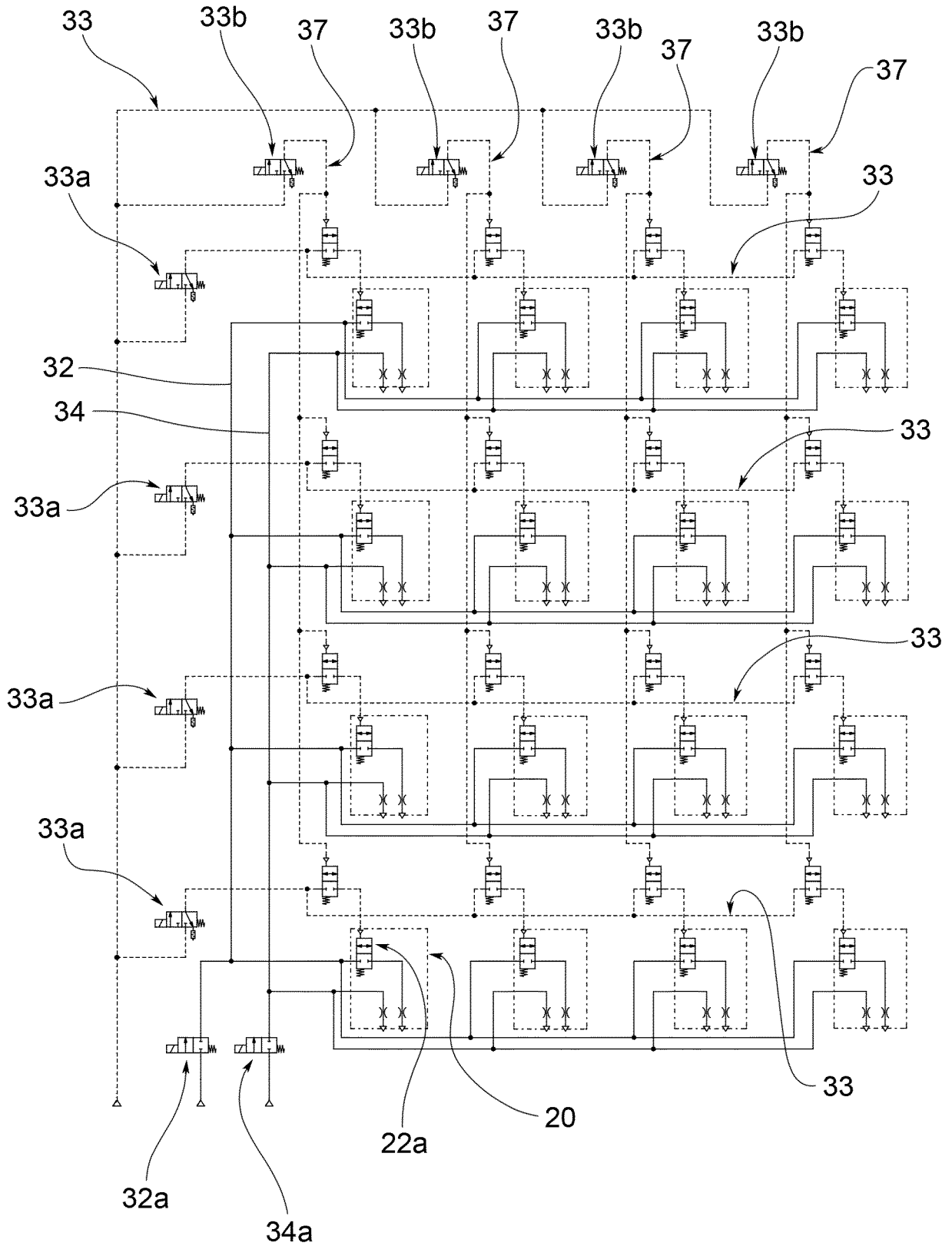

FIG. 7

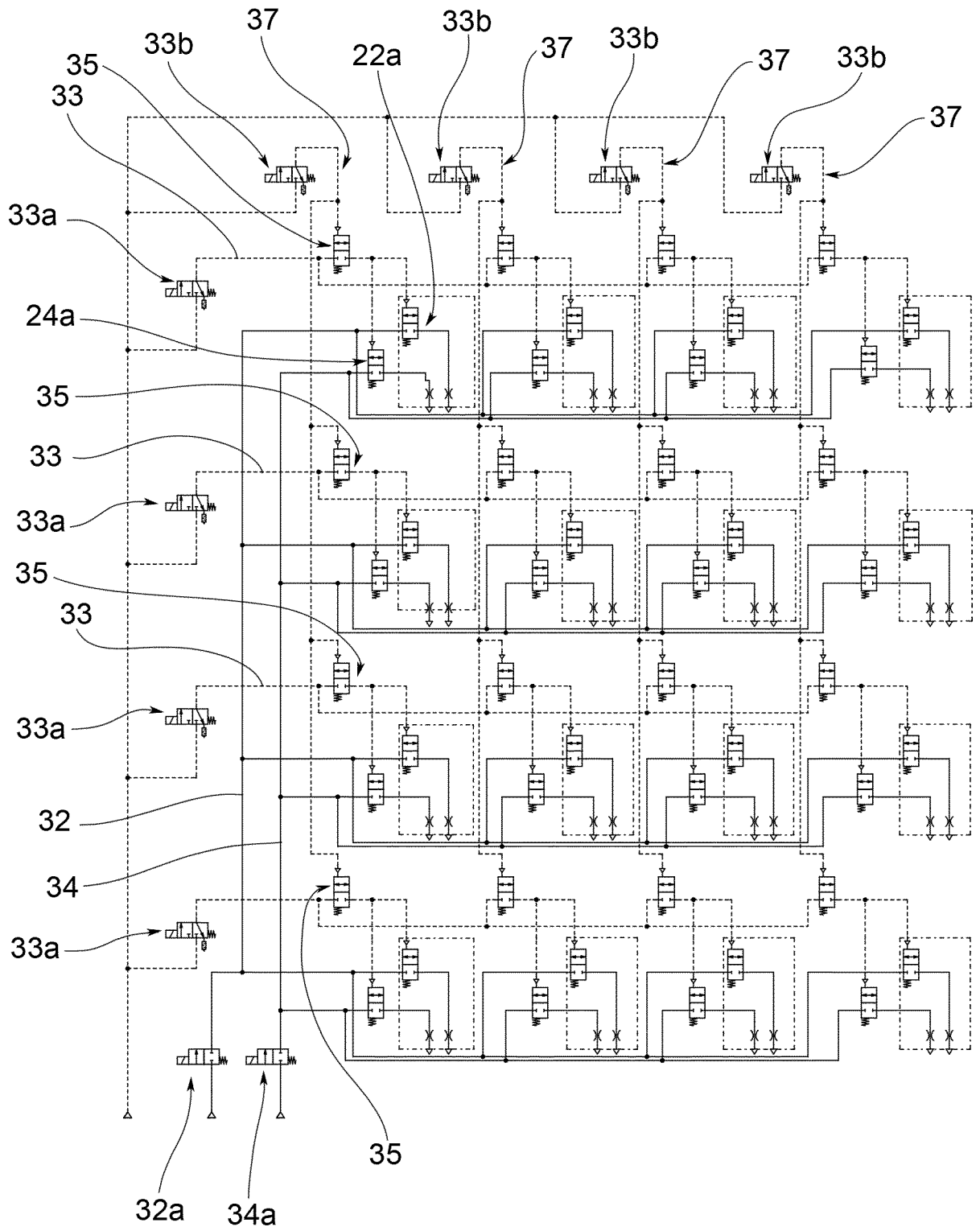

FIG.8

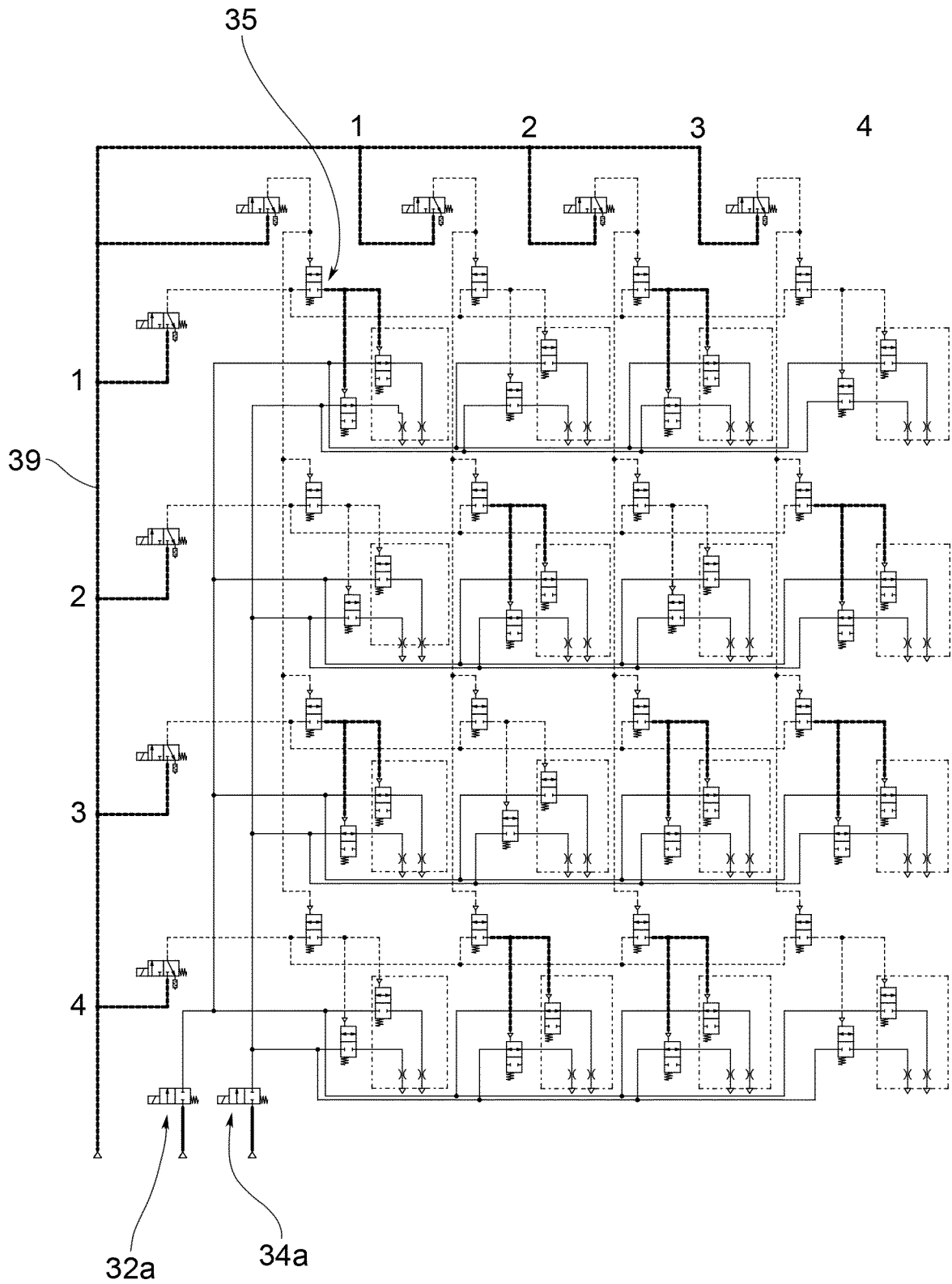

FIG.9

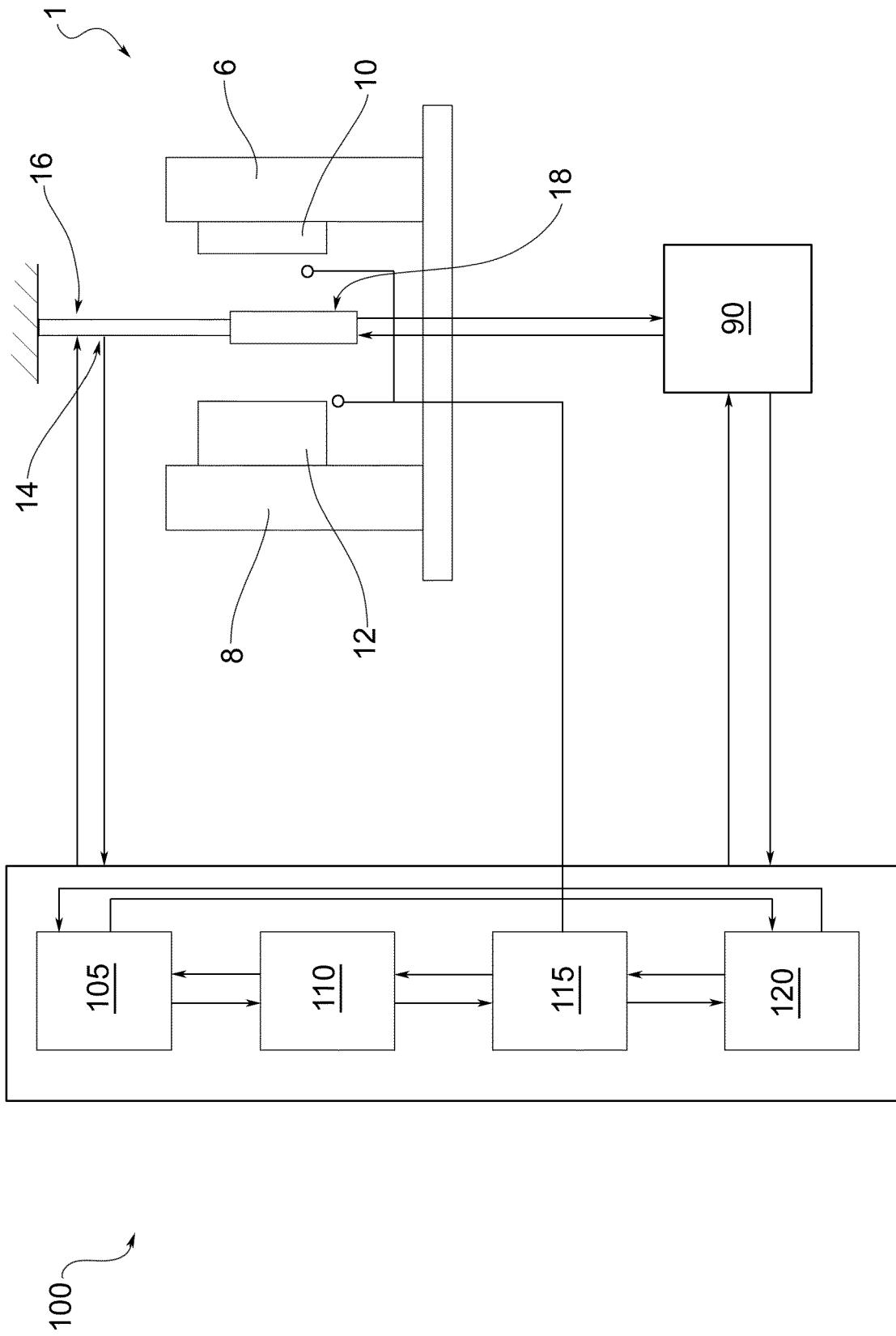

FIG.10

**REFERENCES CITED IN THE DESCRIPTION**

*This list of references cited by the applicant is for the reader's convenience only. It does not form part of the European patent document. Even though great care has been taken in compiling the references, errors or omissions cannot be excluded and the EPO disclaims all liability in this regard.*

**Patent documents cited in the description**

- US 2014263752 A1 [0007]