

(19)



(11)

EP 4 074 215 A1

(12)

EUROPEAN PATENT APPLICATION

(43) Date of publication:
19.10.2022 Bulletin 2022/42

(51) International Patent Classification (IPC):
A46B 13/00 (2006.01) A46B 15/00 (2006.01)
E01H 1/05 (2006.01) A47L 11/30 (2006.01)

(21) Application number: **21075002.2**

(52) Cooperative Patent Classification (CPC):
A46B 13/008; A46B 15/001; A47L 11/4038;
E01H 1/05; A46B 2200/3066

(22) Date of filing: **14.04.2021**

(84) Designated Contracting States:
AL AT BE BG CH CY CZ DE DK EE ES FI FR GB
GR HR HU IE IS IT LI LT LU LV MC MK MT NL NO
PL PT RO RS SE SI SK SM TR
Designated Extension States:
BA ME
Designated Validation States:
KH MA MD TN

(71) Applicant: **Koti Onroerend Goed b.v.**
6003 DG Weert (NL)
(72) Inventor: **Huybreckx, Michel Jozef René Lambert**
6003 DG Weert (NL)

(54) **WEAR INDICATOR PIN FOR ROTARY SWEEPING DISH BRUSHES**

(57) The invention concerns a wear indicator pin (8) for rotary sweeping dish brushes (1), wherein said wear indicator pin (8) is installed by means of a bore hole (7) in the slightly uprising contour edge (3) or rim of mentioned circular dish plate (2). The number of wear indi-

cator pins (8) is between 1 and 4 , preferably 1 or 2. So the wear indicator pins (8) are placed between the sweeping elements (6) and are coloured executed for good sight from the outside and give clear information for the wear situation and replacement of a dish brush (1).

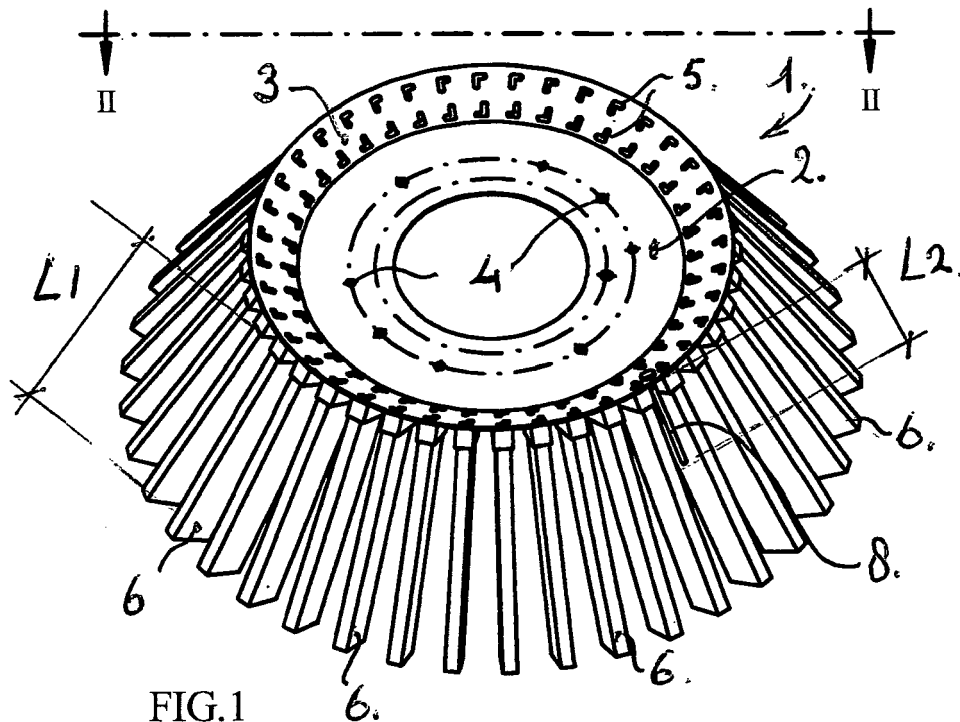

EP 4 074 215 A1

Description

[0001] The present invention concerns a special wear indicator pin which is placed into an applied bore hole on the slightly uprising contour edge of a rotary sweeping dish brush mounted under a conventional sweeping machine. Said pin gives a clear indication of how far the wear of the dish brush has progressed in order to decide when to replace the old brush by a new dish brush. In practice, this is important for a good result of the sweeping activities on pavements.

Background of the invention.

[0002] The state of the art does not include an effective system for indicating the wear situation of a rotary sweeping dish brush. In practice it is very important to estimate the wear situation of said dish brush in order to achieve a good cleaning of the pavements. It happens to be an important issue to replace the worn-off dish brush in time. The usually known dish brushes do not have such an indication mark.

[0003] Object of the invention.

[0004] To eliminate the drawback of the non-indicating wear situation of dish brushes an effective wear indicator mark has been developed. The developed wear indicator mark or pin can be installed in the slightly uprising contour edge of the dish brush plate. See, for example, dish brush plate EP 19075004, filed 01-03-2019, titled: "Dish Brush for Sweeping Machines", applicant KOTI Onroerend Goed B.V., Weert, The Netherlands.

Summary of the invention.

[0005] Wear indicator pin for rotary sweeping dish brushed, which are place or mounted at a rotating vertical driving axle under a conventional sweeping machine. The dish brush consists of a circular plate with a slightly uprising contour edge or rim, wherein at mutually equal tangential distances sweeping elements are fixed (welded) at the bottom side of said contour edge, characterized in that in the contour edge or rim between said sweeping elements with length L_1 , n extra bore holes are fixed with diameter D and wherein is pulled or installed a nail-formed coloured wear indicator pin, wherein said wear indicator pins have a pin diameter d_1 , a conical end diameter d_2 , a ring diameter d_1 , a nail head diameter d_3 and an effective length L_2 , wherein $L_2 < L_1$, wherein the material of said wear indicator pin is made from a coloured plastic material.

[0006] The advantage is an excellent view on the wear situation of the rotary sweeping dish brushed mounted under a conventional sweeping machine shown from a side view. The dish brush can be replaced in time in order to achieve an optimal sweeping result.

[0007] Furthermore, the wear indicator pin as in claim 1 is further characterized in that said length L_2 is between $1/6 L_1$ and $1/3 L_1$, preferably $1/5 L_1$. The advantage is

an optimal use of the dish brush before replacement.

[0008] Then the wear indicator pin as in claim 1-2 is further characterized in that said n is between 1 and 4, preferably 1 or 2. The advantage is that the wear and tear of the dish brush can be seen from different sides.

[0009] Furthermore, the wear indicator pin as in claim 1-3 is further characterized in that said diameter d_1 is about 95% of diameter D and that diameter d_2 is about 110% of diameter D , being 6 mm. The advantage is a very easy and fast mounting or pulling of a wear indicator pin.

[0010] Then the wear indicator pin as in claim 1-4 is further characterized in that said nail head diameter d_3 is 15 mm. The advantage is a very stable and strong mounting of the head of the wear indicator pin.

[0011] Furthermore, the wear indicator pin as in claim 1-5 is further characterized in that said plastic material is polyethylene, wherein said colour is chosen as yellow, red, green or blue. If required other colours can be chosen. The advantages are a strong, flexible (bending strength) product, executed as wear indicator pin, in different colours.

Brief description of the drawing.

[0012] The embodiment of the wear indicator pin is mounted in the slightly uprising contour edge of rim of the circular plate of a dish brush according to the invention which will now be described below. This is by way of example with reference to the accompanying drawing with figures, in which:

figure 1 shows an oblique projection of the rotary sweeping dish brush with sweeping elements and at least one wear indicator pin according to the invention;

figure 2 shows a top view over the line II-II of the circular plate of a rotary sweeping dish brush with on wear indicator pin;

figure 3 shows a cross section over the line III-III of figure 2 with only one wear indicator pin; and

figure 4 shows an oblique side view of the wear indicator pin according to the invention.

Detailed description

[0013] Figure 1 shows an oblique projection of the rotary sweeping dish brush 1 with a circular plate and a slightly uprising contour edge or rime 3. The circular plate 2 has mounting or installation holes 4 for coupling to the vertical axle of a sweeping machine (not shown). Underneath through the L-formed openings 5 the sweeping elements 6 are welded under the contour edge or rim 3. The wear indicator pin 8 is pulled through a mentioned bore hole 7. The length L_2 of said wear indicator pin 8 is between 70 mm and 110 mm depending on the diameter of the dish brush 1. The material itself is polyethylene and can be coloured yellow, red, green or blue. If required

another colour can be chosen. The length L1 of the sweeping elements 6 is between 240 mm and 290 mm, preferably 270 mm. The length L2 will be about 90 mm, being 1/3 of L1.

[0014] Figure 2 shows a top view over the line II-II of figure 1 of the circular plate 2 and the slightly uprising edge or rim 3. Only one bore hole 7 is indicated for pulling through said wear indicator pin 8. In practice, more wear indicator pins 8 can be installed.

[0015] Figure 3 shows a cross section over the line III-III of figure 2. The same elements have the same numbers.

[0016] Figure 4 shows an oblique side view of the wear indicator pin 8 according to the invention. The same elements have also the same numbers. The diameter d1 is around 6 mm and the conical diameter d2 is around 7,5 mm. The nail head 9 has a diameter d3 of 15 mm. The bore hole diameter D with number 7 is 6,5 mm.

[0017] However, it is obvious that modifications to the aforementioned wear indicator pin 8 according to the invention can be made, but these shall remain within the field and scope of the invention.

material is polyethylene.

7. Wear indicator pin as in claim 6, **wherein** said chosen colour can be yellow, red, green or blue.

Claims

1. Wear indicator pin for rotary sweeping dish brushes mounted at a rotating vertical driving axle under a conventional sweeping machine for sweeping or cleaning paved surfaces, wherein said dish brush consists of a circular plate with a slightly uprising contour edge or rim, wherein are mutually equal tangential distances said sweeping elements are fixed or mounted at the bottom side, **characterized in that** bore holes (7) with diameter D are fixed in the contour edge (3) or rim between said sweeping elements (6) with length L1,n and wherein nail-formed coloured wear indicator pins (8) are pulled or installed, wherein said wear indicator pins (8) have a diameter d1, a conical end diameter d2, next a ring diameter d1, a nail head with diameter d3 and an effective length L2, wherein $L2 < L1$, wherein the material of said wear indicator pin (8) is made from a coloured plastic.
2. Wear indicator pin as in claim 1, **wherein** said length L2 is between $1/4 L1$ and $1/2 L1$, preferably $1/3 L1$.
3. Wear indicator pin as in claim 1-3, **wherein** said n is between 1 and 4, preferably 1 or 2.
4. Wear indicator pin as in claim 1-3, **wherein** said diameter d1 is around 95% of diameter D and diameter d2 is around 110% of diameter D being 6 mm.
5. Wear indicator pin as in claim 1-4, **wherein** said nail head diameter d3 is 15 mm.
6. Wear indicator pin as in claim 1, **wherein** said plastic

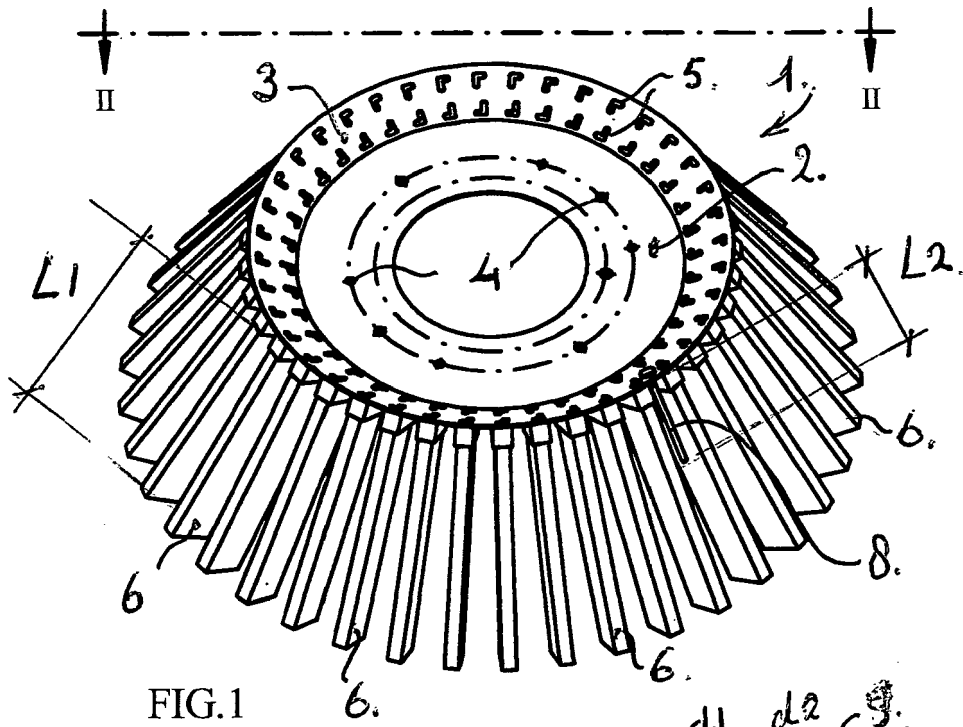

FIG. 1

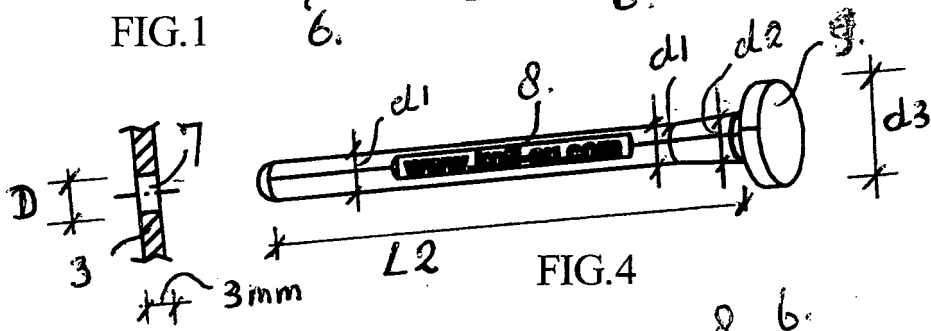

FIG. 4

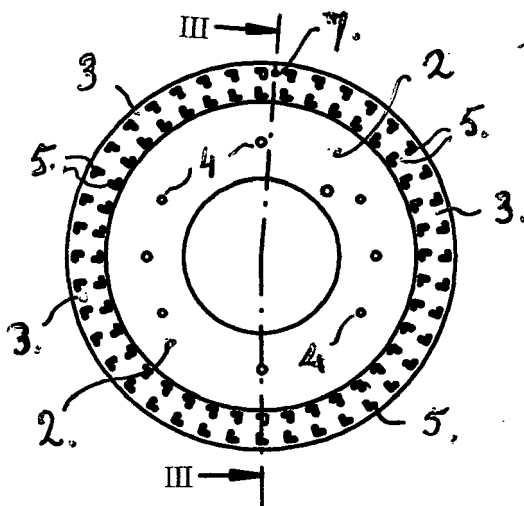

FIG. 2

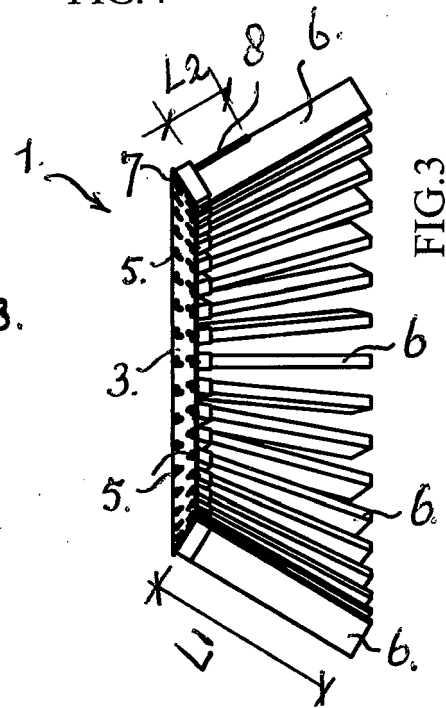

FIG. 3



EUROPEAN SEARCH REPORT

Application Number
EP 21 07 5002

5

10

15

20

25

30

35

40

45

50

55

DOCUMENTS CONSIDERED TO BE RELEVANT			
Category	Citation of document with indication, where appropriate, of relevant passages	Relevant to claim	CLASSIFICATION OF THE APPLICATION (IPC)
X	JP H07 177933 A (WINDSOR IND INC) 18 July 1995 (1995-07-18) * paragraphs [0007], [0028], [0032]; figures 7, 8 * -----	1-7	INV. A46B13/00 A46B15/00 E01H1/05 A47L11/30
			TECHNICAL FIELDS SEARCHED (IPC)
			A46B E01H A47L
The present search report has been drawn up for all claims			
Place of search The Hague		Date of completion of the search 8 September 2021	Examiner Kun, Karla
CATEGORY OF CITED DOCUMENTS		T : theory or principle underlying the invention E : earlier patent document, but published on, or after the filing date D : document cited in the application L : document cited for other reasons & : member of the same patent family, corresponding document	
X : particularly relevant if taken alone Y : particularly relevant if combined with another document of the same category A : technological background O : non-written disclosure P : intermediate document			

1
EPO FORM 1503 03.02 (P04C01)

**ANNEX TO THE EUROPEAN SEARCH REPORT
ON EUROPEAN PATENT APPLICATION NO.**

EP 21 07 5002

5 This annex lists the patent family members relating to the patent documents cited in the above-mentioned European search report.
The members are as contained in the European Patent Office EDP file on
The European Patent Office is in no way liable for these particulars which are merely given for the purpose of information.

08-09-2021

10	Patent document cited in search report	Publication date	Patent family member(s)	Publication date
	JP H07177933 A	18-07-1995	EP 0649626 A2	26-04-1995
			JP H07177933 A	18-07-1995
15			US 5455979 A	10-10-1995

20				
25				
30				
35				
40				
45				
50				
55				

EPO FORM P0459

For more details about this annex : see Official Journal of the European Patent Office, No. 12/82

REFERENCES CITED IN THE DESCRIPTION

This list of references cited by the applicant is for the reader's convenience only. It does not form part of the European patent document. Even though great care has been taken in compiling the references, errors or omissions cannot be excluded and the EPO disclaims all liability in this regard.

Patent documents cited in the description

- EP 19075004 A [0004]