

(19)



(11)

EP 4 095 055 B1

(12)

EUROPEAN PATENT SPECIFICATION

(45) Date of publication and mention of the grant of the patent:
15.05.2024 Bulletin 2024/20

(51) International Patent Classification (IPC):
B65D 8/00 ^(2006.01) **B65D 6/06** ^(2006.01)
B65D 25/24 ^(2006.01)

(21) Application number: **22175579.6**

(52) Cooperative Patent Classification (CPC):
B65D 25/24; B65D 11/06; B65D 77/06

(22) Date of filing: **25.05.2022**

(54) KEG FOR LIQUIDS AND CORRESPONDING PRODUCTION METHOD

FASS FÜR FLÜSSIGKEITEN UND ENTSPRECHENDES HERSTELLUNGSVERFAHREN
BARIL POUR LIQUIDES ET PROCÉDÉ DE FABRICATION CORRESPONDANT

(84) Designated Contracting States:
AL AT BE BG CH CY CZ DE DK EE ES FI FR GB GR HR HU IE IS IT LI LT LU LV MC MK MT NL NO PL PT RO RS SE SI SK SM TR

(74) Representative: **Petraz, Gilberto Luigi et al**
GLP S.r.l.
Viale Europa Unita, 171
33100 Udine (IT)

(30) Priority: **27.05.2021 IT 202100013892**

(56) References cited:
WO-A1-2011/143724 GB-A- 2 532 223
US-A- D 912 520 US-B1- 6 386 384
US-B1- 6 662 963

(43) Date of publication of application:
30.11.2022 Bulletin 2022/48

(73) Proprietor: **Covi, Emanuela**
39012 Merano (BZ) (IT)

Remarks:

The file contains technical information submitted after the application was filed and not included in this specification

(72) Inventor: **Covi, Emanuela**
39012 Merano (BZ) (IT)

EP 4 095 055 B1

Note: Within nine months of the publication of the mention of the grant of the European patent in the European Patent Bulletin, any person may give notice to the European Patent Office of opposition to that patent, in accordance with the Implementing Regulations. Notice of opposition shall not be deemed to have been filed until the opposition fee has been paid. (Art. 99(1) European Patent Convention).

Description

FIELD OF THE INVENTION

[0001] Embodiments described here concern a keg for liquids comprising a container, suitable to contain, for example, food beverages or other liquids, and a base support with which the container is associated to keep it in a substantially vertical position. The present invention also concerns the method for producing the keg.

BACKGROUND OF THE INVENTION

[0002] It is known that large volumes of carbonated or non-carbonated beverages are generally delivered to the place of consumption in drums, also known as "kegs".

[0003] Typically, a keg comprises a container and a base support for the container.

[0004] The container is generally made of metal or plastic material. In the latter case, the container can comprise a rigid external body and an autonomous flexible internal containing body designed to contain the liquid. The external container does not normally damage, nor can it damage, the internal container.

[0005] In the case of plastic kegs, the external container generally comprises a cylindrical lateral wall, an upper wall which normally, although not necessarily, incorporates closing means, as well as possibly introduction and extraction means, and a bottom wall advantageously, even if not necessarily, rounded.

[0006] A handling element, advantageously annular, is associated with the upper portion of the container, which allows to facilitate the movement of the container for transport and use, as well as for stacking.

[0007] The bottom wall is coupled in an irremovable manner with the base support which has a double function: to allow the support and stable positioning of the container, as well as to allow the stacking of the containers. Stacking is possible thanks to the desired and defined coupling that occurs between the base support of a first container and the handling element of a second container put below it.

[0008] During transport, storage and handling for putting them into use and also during use, the kegs are subject to considerable stresses, especially in the zone where the container and the base support are attached.

[0009] For this reason, currently, the coupling between them occurs by the gluing or welding to each other of reciprocal coupling surfaces of the bottom bell and the base support, that is, by connecting the reciprocal coupling surfaces in an irremovable manner.

[0010] This entails the disadvantage that the process for the production of the kegs is particularly complex because, in addition to obtaining the keg and the production of the base support, a coupling step by gluing or welding is required.

[0011] Furthermore, since the two components, container and base support, are not separable, or rather they

are difficult to separate and with the risk of breaking, in the event of damage to one or the other component it is necessary to replace the entire keg or continue to use it in precarious conditions of handling and storage.

[0012] Documents US 6,662,963 B1, WO 2011/143724 A1 and US D 912 520 A describe or show kegs for beverages of a known type.

[0013] There is therefore a need to perfect a keg for liquids which can overcome at least one of the disadvantages of the state of the art.

[0014] In particular, one purpose of the present invention is to provide a keg in which the coupling between the container and base support is facilitated, possibly also making it possible to replace one or the other component with reasonable ease, and at the same time obtaining a safe and stable connection of the components.

[0015] Another purpose is to provide a base support on which the weight of the container is distributed homogeneously and over a wider surface, thus reducing the stresses on the base support itself, and which allows to stably position the container both on a support surface, and also stacked on top of another keg.

[0016] Another purpose of the present invention is to provide a keg with a simpler, faster and less expensive production method, without further waste of labor, in which the coupling of the container and the base support can also take place at a later time or in a different place.

[0017] It is also a purpose to provide that the replacement of one or the other component can take place quickly, without difficulty, without special tools or equipment and without the risk of irreparably damaging one or both.

[0018] Another purpose is to perfect a method for producing the keg, and to keep it usable, complete with the base support, which is simpler and requires fewer steps than those currently known, reducing costs and at the same time reducing waste.

[0019] The Applicant has devised, tested and embodied the present invention to overcome the shortcomings of the state of the art and to obtain these and other purposes and advantages.

SUMMARY OF THE INVENTION

[0020] The present invention is set forth and characterized in the independent claims 1 and 12. The dependent claims describe other characteristics of the present invention or variants to the main inventive idea.

[0021] In accordance with the above purposes, a keg for liquids which overcomes the limits of the state of the art and eliminates the defects present therein comprises a container provided with an at least partly rounded bottom wall which is provided with anchoring means located circumferentially.

[0022] The keg also comprises a base support comprising a containing cradle having a shape at least partly mating with the bottom wall and provided with connection means which are stable, albeit able to be disconnected, wherein the anchoring means and the connection means

are mating and such as to generate a desired and stable, albeit removable, connection between the container and the base support.

[0023] The anchoring means comprise at least one groove and the connection means comprise one or more protruding portions configured to be inserted into the at least one groove.

[0024] According to some embodiments of the invention, the container preferably comprises an external support body and an autonomous internal bag substantially coaxial to the external support body, defining a chamber for containing the liquid.

[0025] In this case, the anchoring means and the connection means are such as not to affect the stability or integrity of the autonomous chamber for containing the liquid over time.

[0026] The groove is made continuous along the circumference of the rounded bottom wall and the connection means comprise a plurality of protruding portions made in the form of fins, equally distanced around a central axis.

[0027] Providing a continuous groove on the container and a plurality of protruding portions on the base support simplifies the production of the container itself, normally carried out by blowing suitable preforms inside a mold.

[0028] Furthermore, the continuous groove allows to hook and interlock the base support to the container in any position, without requiring a particular reciprocal orientation between the two elements.

[0029] Another advantage given by providing a continuous groove on the container and a plurality of discontinuous protruding portions on the base support is given by the fact that this conformation allows to supply a certain degree of flexibility to the more rigid component, that is, the base support, to allow it to be inserted into the groove, so that the mechanical connection is more stable.

[0030] According to other embodiments, the connection means are made in continuity with an upper edge of the base support and are conformed in such a way that, in the assembled condition of the container and of the base support, the upper edge is positioned inside the groove. This allows to obtain a better distribution of the weight of the container on the base support and to guarantee a better seal of the reciprocal coupling, in particular when the container is filled with the beverage and therefore is heavier, at the same time making the separation easier when the container is empty.

[0031] According to other embodiments, centrally, the bottom wall has an extension, that is, a protruding part, configured to be inserted into a mating bottom hole of the base support.

[0032] According to a preferred embodiment, the protruding part is preferably centered with respect to the axis of the container and has a shape that is coherent with the shape and size of the bottom hole.

[0033] The further coupling between the container and the base support that occurs between the protruding portion and the bottom hole allows to correctly align the two

components with respect to each other, so as to guarantee greater stability even in the case in which the kegs are disposed one on top of the other.

[0034] In accordance with some embodiments, a method for producing such a keg for liquids is provided, comprising:

- a step of supplying a container comprising an at least partly rounded bottom wall provided circumferentially with anchoring means;
- a step of supplying a base support having a containing cradle with a shape at least partly mating with the bottom wall and provided with connection means which are stable, albeit able to be disconnected;
- a step of reciprocal mechanical coupling between the connection means and the anchoring means to generate a stable, but reversible and removable, connection between the container and the base support.

[0035] According to one aspect of the invention, the anchoring means comprise a groove and the connection means are of the protruding type and are made in continuity with an upper edge of the base support, and the method provides to insert the connection means in the groove in such a way that the upper edge is disposed at least partly inside the groove and abutting against an upper shoulder.

[0036] According to another aspect of the invention, the method provides to insert a protruding part of the container which extends from the bottom wall inside a mating bottom hole of the base support so as to align the container and the base support along a common axis.

DESCRIPTION OF THE DRAWINGS

[0037] These and other aspects, characteristics and advantages of the present invention will become apparent from the following description of some embodiments, given as a non-restrictive example with reference to the attached drawings wherein:

- fig. 1 is a lateral view of a keg for liquids in accordance with some embodiments described here;
- fig. 2 is a view of the keg of fig. 1 with the components separated;
- fig. 3 is an enlarged detail of a longitudinal section of the keg of fig. 1;
- fig. 3a is an enlarged detail of fig. 3;
- fig. 4 is view of fig. 3 with the components separated;
- fig. 4a is an enlarged detail of fig. 4;
- fig. 5 is a perspective view of the base support of figs. 1-4;
- fig. 5a is an enlarged detail of fig. 5;
- fig. 6 is a top plan view of fig. 5.

[0038] To facilitate comprehension, the same reference numbers have been used, where possible, to iden-

tify identical common elements in the drawings. It is understood that elements and characteristics of one embodiment can be conveniently combined or incorporated into other embodiments without further clarifications.

DESCRIPTION OF SOME EMBODIMENTS

[0039] We will now refer in detail to the possible embodiments of the invention, of which one or more examples are shown in the attached drawings, by way of a non-limiting illustration. The phraseology and terminology used here is also for the purposes of providing non-limiting examples.

[0040] With particular reference to figs. 1-2, these show a drum 10, which is also referred to as keg in the sector.

[0041] The keg 10 comprises a container 11 made of plastic material, suitable to contain liquids or fluids, advantageously but not limitedly beverages, food products, pharmaceutical products, cleaning or sanitizing products.

[0042] By way of example, the liquids can be carbonated beverages, such as beer, sparkling wine, soft drinks or other liquids, whether food, for example wine or oil, or detergents, diluents, sanitary or hospital liquids, or other liquid products for industry, trade or healthcare.

[0043] According to some embodiments, for example shown in fig. 3, the container 11 comprises a flexible and compressible internal bag 11a and an external support body 11b which is suitable to give a certain rigidity to the container 11.

[0044] The internal bag 11a and the external support body 11b are separated by a hollow space 37 into which, when the beverage is delivered, a pressurized fluid is injected, such as for example air or carbon dioxide, thanks to which it is possible to determine the compression of the internal bag 11a and determine the dispensing of the liquid, while the external support body 11b acts as a containing and contrast element for the fluid.

[0045] The container 11 comprises a lateral wall 12 ending in a bottom wall 13 which is advantageously at least partly rounded and provided circumferentially with anchoring means 14.

[0046] The anchoring means 14 are preferably of the recessed type, as for example visible in fig. 2.

[0047] However, some variants can be provided, not shown, in which the anchoring means 14 are of the protruding type.

[0048] The lateral wall 12 has a substantially cylindrical shape; however, other more or less complex shapes are not excluded, for example polygonal, more or less oval, or suchlike.

[0049] According to some embodiments, shown in figs. 1-4, the bottom wall 13 has an at least partly rounded shape and is substantially convex. More particularly, the bottom wall 13 has, at least partly, a dome or hemisphere shape.

[0050] The keg 10 also comprises a base support 15

having a containing cradle 16 at least partly mating in shape with the bottom wall 13.

[0051] Preferably, the containing cradle 16 has an internal profile substantially the same as that of the bottom wall 13, in such a way as to present a wide contact surface allowing a better distribution of the weight of the container 11.

[0052] The containing cradle 16 is provided circumferentially with connection means 17 to define a reversible mechanical coupling with the connection portion 14, in order to stabilize the position of the container 11 on the base support 15.

[0053] The connection means 17 are advantageously of the protruding type, as for example visible in figs. 3-5, suitable to cooperate with anchoring means 14 of the recessed type.

[0054] According to possible variants, not shown, the connection means 17 can be of the recessed type, suitable to cooperate with anchoring means 14 of the protruding type.

[0055] The anchoring means 14 comprise, or are conformed as, at least one groove 18 made in the bottom wall 13.

[0056] The groove 18 is continuous, that is, it does not have any interruptions along the circumferential development.

[0057] Providing a continuous groove 18 facilitates the production of the container 11, which typically occurs by blowing one, or preferably two, coaxial pre-shapes made of plastic material, one of which is internal, and the other is external, respectively designated to form the internal bag 11a and the external support body 11b.

[0058] The groove 18 can appear as a shaped recess. In particular, the groove 18 can substantially have a C-shaped section with the access aperture facing toward the outside of the container 11.

[0059] With particular reference to the example embodiment of fig. 4a, the groove 18 has an upper shoulder 18a substantially orthogonal to an axis of development X of the container 11, a central abutment surface 18b and a lower shoulder 18c which is slightly inclined with respect to the axis of development X and which defines a sort of gripping inlet.

[0060] In particular, the central abutment surface 18b is inclined with respect to the axis X of the container by a seating angle α comprised between about 20° and about 40°, preferably about 30°. The seating angle α thus defined facilitates the coupling of the container 11 with the base support 12.

[0061] The groove 18 is open only in the radial direction and has a height H measured between the upper shoulder 18a and the lower shoulder 18c such as to allow the insertion of the connection means 17.

[0062] According to some embodiments, the groove 18 is positioned in an intermediate zone of the convex bottom wall 13, dividing the bottom wall substantially into two parts 13a, 13b.

[0063] In particular, the groove 18 can be disposed in

the lower half of the bottom wall 13, preferably in a zone comprised between 50% and 30% of its lower extension. This position allows to define a stable coupling between the container 11 and the base support 15, because it allows a wide surface of the container 11 to be supported during use, preventing the occurrence of sliding or axial inclinations.

[0064] According to a variant, the bottom wall 13 has an extension, that is, a protruding part 19, configured to be inserted into a mating bottom hole 21 of the base support 15. This configuration allows to increase the stability of the coupling and facilitate the centering of the container 11 during the insertion into the base support 15.

[0065] The protruding part 19 is preferably centered with respect to the axis X of the container 11 and it can have a substantially cylindrical shape with a rounded bottom and edges, or have a different section, in any case coherent with the shape and size of the bottom hole 21.

[0066] In particular, the protruding part 19 is configured to be at least partly inserted in the bottom hole, so that a lateral wall of the protruding part 19 is positioned directly in contact with an internal wall of the bottom hole 21.

[0067] In this way, it is possible to further guarantee a correct alignment between the container 11 and the base support 15 along the axis X, allowing to position multiple kegs 10 on top of each other without the risk of possible falls.

[0068] According to some embodiments, the coupling between the protruding part 19 and the bottom hole 21 can occur by means of a same-shape coupling.

[0069] According to one variant, reciprocal means for stable or reversible connection, of a known type, can be present between the protruding part 19 and the bottom hole 21.

[0070] According to some embodiments, the container 11 also comprises an upper wall 22, opposite to the bottom wall 13, which also has an at least partly rounded profile ending in a mouthpiece 23 which can be advantageously equipped with tapping means for delivering the beverage (fig. 1).

[0071] The container 11 can be able to cooperate advantageously with an annular-shaped grip handwheel 25 suitable to handle and move the container 11. The grip handwheel 25 can be attached to the upper wall 22 of the container 11 and possibly also to the mouthpiece 23.

[0072] According to some embodiments, the base support 15 has a lower annular edge 27 and an opposite upper annular edge 28, which delimits the access aperture to the containing cradle 16, which are connected to each other by a lateral wall 31.

[0073] The containing cradle 16 has a concave shape, mating with the convex shape of the bottom wall 13 of the container 11.

[0074] According to some embodiments, the containing cradle 16 ends at the top with the connection means 17. In other words, the connection means 17 develop in continuity with the upper annular edge 28.

[0075] According to some embodiments, the connec-

tion means 17 develop circumferentially in an annular manner defining a lateral containing lip 29 and an annular resting edge 30.

[0076] The connection means 17 comprise a plurality of protruding portions 35 made in the form of fins

[0077] The protruding portions 35 are at least partly mating in the shape with the groove 18. The protruding portions 35 are configured to create a reversible mechanical coupling with the groove 18, for example a same-shape coupling of the click-fit or snap type.

[0078] In the embodiment described here, and with particular reference to fig. 6, the connection means 17 comprise six protruding portions 35 equally distanced circumferentially with respect to the central axis Y. It is clear, however, that the number of protruding portions 35, and possibly also their size in the radial and/or circumferential direction, can vary as a function of the size and/or shape of the container 11 and of the shape of the anchoring means 14 with which they have to cooperate.

[0079] According to some embodiments, for example described with reference to fig. 4, each protruding portion 35 is inclined toward the central axis Y of the base support 15 by an interlocking angle β that is coherent with the seating angle α .

[0080] In the example case, the interlocking angle β is comprised between about 20° and about 40° , preferably about 30° . The interlocking angle β is substantially equal to the seating angle α , preferably smaller by a few degrees.

[0081] Each protruding portion 35 has a free end 35a which, during use, fits into the groove 18, and an opposite constrained end 35b attached to the upper annular edge 28, the free end 35a and the constrained end 35b being connected by respective free lateral edges 35c, 35d.

[0082] Thanks to the fact that they have only one constrained end 35b, the protruding portions 35 are flexible. In particular, the protruding portions 35 are elastically engaged with respect to their constrained end 35b, being able to retract into respective rear apertures 36 which are also made in the interlocking portion 17, in particular in the lateral containing lip 29. This elastic configuration allows to create a substantially radial thrust of the fins 35 in the groove 18, increasing the stability of the coupling.

[0083] With reference to the enlarged detail of fig. 3a, we note that when the protruding portion 35 is inserted into the groove 18, the constrained end 35b and part of the upper annular edge 28 abut against the upper shoulder 18a of the groove 18. This cooperation is advantageous because the weight of the container 11 is distributed not only on the surface of the support cradle 16 but also on the upper annular edge 28.

[0084] According to possible embodiments, the free end 35a can abut against the lower shoulder 18c of the groove 18.

[0085] The base support 15 has an external shape that is substantially truncated conical with respect to the central axis Y, wherein the lower annular edge 27 has an external diameter greater than the diameter of the upper

annular edge 28. This shape of the base support 15 increases its the resting stability and therefore that of the container 11 when it is coupled with it.

[0086] The containing cradle 16 ends at the bottom in a bottom ring 34, defining the bottom hole 21, which can have a height coherent with that of the protruding part 19 of the container 11, or even greater than it.

[0087] The lateral wall 31 and/or the containing cradle 16 can be provided with a plurality of discharge apertures 32 and/or lateral apertures 39 which are able to make the base support 15 lighter, and more elastic and resistant to axial stresses.

[0088] This measure also allows to make the containing cradle 16 more elastic, increasing its ability to support even very heavy containers 11 and to cushion shocks or axial stresses that occur especially during transport or storage. The discharge apertures 32, for example, can be defined by beads, or ribs, 33 which join the upper annular edge 28 with the bottom ring 34.

[0089] According to some embodiments, the kegs 10 are stackable. In particular, the base support 15 of a first keg 10 is provided at the bottom with a coupling seating 38 conformed to accommodate the grip handwheel 25 of a second keg 10, so that the kegs 10 can be stacked one on top of the other.

[0090] Some embodiments described here also concern a method for producing a keg 10 for liquids, comprising:

- a step of supplying a container 11 provided with an at least partly rounded bottom wall 13 provided circumferentially with anchoring means 14;
- a step of supplying a base support 15 having a containing cradle 16 at least partly mating in shape with the bottom wall 13 and provided with stable connection means 17, albeit able to be disconnected;
- a step of reciprocal coupling between the connection means 17 and the anchoring means 14 to generate a stable, but reversible and removable, connection between the container 11 and the base support 15.

[0091] According to some embodiments, the anchoring means 14 are of the recessed type and comprise a groove 18, and the connection means 17 are of the protruding type and are made in continuity with the upper edge 28 of the base support 15, and the method provides to insert the connection means 17 in the groove 18 in such a way that the upper edge 28 is disposed inside the groove 18 and abutting against the upper shoulder 18a.

[0092] The method also provides to insert the protruding part 19 of the container 11 inside the bottom hole 21 of the base support 15 so as to align the container 11 and the base support 15 along a common axis X.

[0093] In the following claims, the sole purpose of the references in brackets is to facilitate reading and they must not be considered as restrictive factors with regard to the field of protection claimed in the specific claims.

Claims

1. Keg (10) for liquids made of plastic material, comprising a container (11) and a base support (15), said container (11) comprising an at least partly rounded bottom wall (13), provided with anchoring means (14) located circumferentially, and said base support (15) comprises a containing cradle (16) having a shape at least partly mating with said bottom wall (13) and provided with connection means (17) which are stable, albeit able to be disconnected, said anchoring means (14) and said connection means (17) being such as to generate a connection and a desired and stable, albeit removable, same-shape coupling of the click-fit or snap-fit type between said container (11) and said base support (15), said anchoring means (14) comprise at least one circumferential groove (18) which is made continuous on the entire circumference of said bottom wall (13) and said connection means (17) comprise a plurality of protruding portions (35) made in the form of fins configured to be inserted into said at least one groove (18), **characterized in that** said base support (15) has an external shape that is substantially truncated conical with respect to a central axis (Y), wherein a lower annular edge (27) has an external diameter greater than the diameter of an upper annular edge (28).
2. Keg (10) as in claim 1, **characterized in that** said protruding portions (35) made in the form of fins are equally distanced with respect to a central axis (Y), which extend substantially rectilinear and inclined with respect to a central axis (Y) of said base support (15) by an interlocking angle (β) comprised between 20° and 40°.
3. Keg (10) as in one or the other of claims 1 or 2, **characterized in that** said protruding portions (35) are flexible with respect to one constrained end (35b) thereof and are associated with respective rear apertures (36) made in said containing cradle (16).
4. Keg (10) as in any claim hereinbefore, **characterized in that** said protruding portions (35) are able to abut at least with one constrained end (35b) thereof against an upper shoulder (18a) of said groove (18).
5. Keg (10) as in any claim hereinbefore, **characterized in that** said groove (18) has a central abutment surface (18b) inclined by a seating angle (α) with respect to an axis (X) of the container (11) comprised between 20° and 40°.
6. Keg (10) as in claims 2 and 5, **characterized in that** said interlocking angle (β) is substantially equal to or slightly smaller than said seating angle (α).
7. Keg (10) as in any claim hereinbefore, **character-**

ized in that said bottom wall (13) centrally has an extension, that is, a protruding part (19), configured to be inserted into a mating bottom hole (21) of said base support (15).

8. Keg (10) as in claim 7, **characterized in that** said protruding part (19) is centered with respect to an axis (X) of said container (11) and has a shape that is coherent with the shape and size of said hole bottom (21) and is at least partly inserted therein.

9. Keg (10) as in any claim hereinbefore, **characterized in that** said groove (18) is positioned in an intermediate zone of said rounded bottom wall (13), preferably in the lower half of said bottom wall (13).

10. Keg (10) as in any claim hereinbefore, **characterized in that** said connection means (17) develop in continuity with an upper annular edge (28) that delimits said containing cradle (16) and, in a condition of coupling between said container (11) and said base support (15), said upper annular edge (28) is positioned inside said groove (18).

11. Keg (10) as in any claim hereinbefore, **characterized in that** it comprises a grip handwheel (25) attached to an upper wall (22) of said container (11) and possibly also to a mouthpiece (23) thereof, and said base support (15) is provided at the bottom with a coupling seating (38) conformed to accommodate the grip handwheel (25) of a second keg (10).

12. Method to produce a keg (10) for liquids as in any claim hereinbefore, comprising:

- a step of supplying a container (11) comprising an at least partly rounded bottom wall (13) provided circumferentially with anchoring means (14);

- a step of supplying a base support (15) having an external shape that is substantially truncated conical with respect to a central axis (Y), wherein a lower annular edge (27) has an external diameter greater than the diameter of an upper annular edge (28) and comprising a containing cradle (16) having a shape at least partly mating with said bottom wall (13) and provided with stable connection means (17), albeit able to be disconnected;

- a step of reciprocal coupling between said connection means (17) and said anchoring means (14) in order to generate a connection and a stable, albeit reversible and removable, same-shape coupling of the click-fit or snap-fit type between said container (11) and said base support (15).

13. Method as in claim 12, **characterized in that** said

anchoring means (14) are of the recessed type and comprise a groove (18) and said connection means (17) are of the protruding type and are made in continuity with an upper edge (28) of said base support (15) and said method provides to insert said connection means (17) into said groove (18) in such a way that said upper edge (28) is disposed at least partly inside said groove (18) and abutting against an upper shoulder (18a).

14. Method as in claim 12 or 13, **characterized in that** it provides to insert a protruding part (19) of said container (11) which extends from said bottom wall (13) inside a mating bottom hole (21) of said base support (15) so as to align said container (11) and said base support (15) along a common axis (X).

Patentansprüche

1. Fass (10) für Flüssigkeiten aus Kunststoffmaterial, umfassend einen Behälter (11) und einen Basisträger (15), wobei der Behälter (11) eine zumindest teilweise abgerundete Bodenwand (13) aufweist, die mit in Umfangsrichtung angeordneten Verankerungsmitteln (14) versehen ist, und wobei der Basisträger (15) einen Aufnahmehalter (16) umfasst, der eine Form aufweist, die zumindest teilweise mit der Bodenwand (13) korrespondiert, und der mit stabilen, jedoch lösbaren Verbindungsmitteln (17) versehen ist, wobei die Verankerungsmittel (14) und die Verbindungsmittel (17) so beschaffen sind, dass sie eine Verbindung und eine gewünschte und stabile, jedoch lösbare, formgleiche Kopplung vom Typ "Click-fit" oder "Snap-fit" zwischen dem Behälter (11) und dem Basisträger (15), erzeugen, wobei die Verankerungsmittel (14) mindestens eine in Umfangsrichtung umlaufende Rille (18) aufweisen, die auf dem gesamten Umfang der Bodenwand (13) fortlaufend ausgestaltet ist, und die Verbindungsmittel (17) eine Vielzahl von vorspringenden Abschnitten (35) umfassen, die in Form von Rippen ausgebildet sind, die so konfiguriert sind, dass sie in die mindestens eine Rille (18) eingesetzt werden können, **dadurch gekennzeichnet, dass** der Basisträger (15) eine äußere Form aufweist, die in Bezug auf eine zentrale Achse (Y) im Wesentlichen kegelstumpfförmig ist, wobei ein unterer ringförmiger Rand (27) einen größeren Außendurchmesser als den Durchmesser eines oberen ringförmigen Rands (28) aufweist.

2. Fass (10) nach Anspruch 1, **dadurch gekennzeichnet, dass** die vorspringenden Abschnitte (35) in Form von Rippen gleichmäßig in Bezug auf eine zentrale Achse (Y) beabstandet sind, die sich im Wesentlichen geradlinig und in Bezug auf eine zentrale Achse (Y) geneigt um einen Verriegelungswinkel (β) zwischen 20° und 40° des Basisträgers (15) erstre-

- cken.
3. Fass (10) nach einem der Ansprüche 1 oder 2, **dadurch gekennzeichnet, dass** die vorspringenden Abschnitte (35) in Bezug auf ein eingespanntes Ende (35b) flexibel sind, und mit den entsprechenden hinteren Öffnungen (36) in dem Aufnahmealter (16) verbunden sind. 5
 4. Fass (10) nach einem der vorhergehenden Ansprüche, **dadurch gekennzeichnet, dass** die vorspringenden Abschnitte (35) in der Lage sind, zumindest mit einem ihrer eingespannten Enden (35b) an einer oberen Schulter (18a) der Rille (18) anzuliegen. 10
 5. Fass (10) nach einem der vorhergehenden Ansprüche, **dadurch gekennzeichnet, dass** die Rille (18) eine zentrale Anlagefläche (18b) aufweist, die um einen Sitzwinkel (α) in Bezug auf eine Achse (X) des Behälters (11) geneigt ist, der zwischen 20° und 40° liegt. 15
 6. Fass (10) nach Anspruch 2 und 5, **dadurch gekennzeichnet, dass** der Verriegelungswinkel (β) im Wesentlichen gleich oder etwas kleiner ist als der Sitzwinkel (α) ist. 20
 7. Fass (10) nach einem der vorhergehenden Ansprüche, **dadurch gekennzeichnet, dass** die Bodenwand (13) in der Mitte eine Verlängerung, d.h. einen vorstehenden Teil (19), aufweist, der so gestaltet ist, dass er in ein korrespondierendes Bodenloch (21) des Basisträgers (15) eingesetzt werden kann. 25
 8. Fass (10) nach Anspruch 7, **dadurch gekennzeichnet, dass** der vorstehende Teil (19) in Bezug auf eine Achse (X) des Behälters (11) zentriert ist und eine Form hat, die mit der Form und Größe des Lochbodens (21) kohärent ist, und zumindest teilweise in diesen eingesetzt ist. 30
 9. Fass (10) nach einem der vorhergehenden Ansprüche, **dadurch gekennzeichnet, dass** die Rille (18) sich in einem Zwischenbereich der abgerundeten Bodenwand (13), vorzugsweise in der unteren Hälfte der Bodenwand (13), befindet. 35
 10. Fass (10) nach einem der vorhergehenden Ansprüche, **dadurch gekennzeichnet, dass** die Verbindungsmittel (17) sich in Kontinuität mit einem oberen ringförmigen Rand (28) entwickelt, der den Aufnahmealter (16) begrenzt, und in einem Zustand der Kopplung zwischen dem Behälter (11) und dem Basisträger (15) sich der obere ringförmige Rand (28) innerhalb der Rille (18) befindet. 40
 11. Fass (10) nach einem der vorhergehenden Ansprüche, **dadurch gekennzeichnet, dass** es ein Griffhandrad (25) umfasst, das an einer oberen Wand (22) des Behälters (11) und möglicherweise auch an einem Mundstück (23) desselben befestigt ist, und dass der Basisträger (15) am Boden mit einem Kuppelungssitz (38) versehen ist, der so angepasst ist, dass er das Griffhandrad (25) eines zweiten Fasses (10) aufnehmen kann. 45
 12. Verfahren zur Herstellung eines Fasses (10) für Flüssigkeiten nach einem der vorhergehenden Ansprüche, umfassend:
 - einen Schritt der Bereitstellung eines Behälters (11), der eine zumindest teilweise abgerundete Bodenwand (13) umfasst, die in Umfangsrichtung mit Verankerungsmitteln (14) versehen ist;
 - einen Schritt des Bereitstellens eines Basisträgers (15), der eine äußere Form hat, die in Bezug auf eine zentrale Achse (Y) im Wesentlichen kegelstumpfförmig ist, wobei ein unterer ringförmiger Rand (27) einen Außendurchmesser hat, der größer ist als der Durchmesser eines oberen ringförmigen Randes (28), und einen Aufnahmealter (16) umfasst, der eine Form hat, die mindestens teilweise mit der Bodenwand (13) korrespondiert und mit stabilen Verbindungsmitteln (17) versehen ist, die jedoch auch gelöst werden können;
 - einen Schritt der wechselseitigen Kopplung zwischen den Verbindungsmitteln (17) und den Verankerungsmitteln (14), um eine Verbindung und eine stabile, jedoch reversible und lösbare, gleichförmige Kupplung vom Typ "Click-Fit" oder "Snap-Fit" zwischen dem Behälter (11) und dem Basisträger (15) zu erzeugen.
 13. Verfahren nach Anspruch 12, **dadurch gekennzeichnet, dass** die Verankerungsmittel (14) vom ausgesparten Typ sind und eine Rille (18) umfassen und die Verbindungsmittel (17) vom vorstehenden Typ sind und in Kontinuität mit einem oberen Rand (28) des Basisträgers (15) hergestellt sind, und das Verfahren vorsieht, die Verbindungsmittel (17) in die Rille (18) so einzufügen, dass der obere Rand (28) zumindest teilweise innerhalb der Rille (18) angeordnet ist und an einer oberen Schulter (18a) anliegt. 50
 14. Verfahren nach Anspruch 12 oder 13, **dadurch gekennzeichnet, dass** es das Einsetzen eines vorstehenden Teils (19) des Behälters (11) vorsieht, der sich von der Bodenwand (13) in ein passendes Bodenloch (21) des Basisträgers (15) erstreckt, um den Behälter (11) und den Basisträger (15) entlang einer gemeinsamen Achse (X) auszurichten. 55

Revendications

1. Fût (10) pour liquides réalisé en matière plastique, comprenant un contenant (11) et un support de base (15), ledit contenant (11) comprenant une paroi de fond (13) au moins partiellement arrondie, pourvue de moyens d'ancrage (14) situés circonférentiellement, et ledit support de base (15) comprend un berceau de confinement (16) présentant une forme s'appariant au moins partiellement à ladite paroi de fond (13) et pourvu de moyens de connexion (17) qui sont stables, bien que pouvant être déconnectés, lesdits moyens d'ancrage (14) et lesdits moyens de connexion (17) étant de nature à générer une connexion et un couplage de même forme souhaité et stable, bien qu'amovible, du type auto-bloquant ou à encliquetage entre ledit contenant (11) et ledit support de base (15), lesdits moyens d'ancrage (14) comprennent au moins une rainure circonférentielle (18) qui est réalisée continue sur toute la circonférence de ladite paroi de fond (13) et lesdits moyens de connexion (17) comprennent une pluralité de parties en saillie (35) réalisées sous la forme d'ailettes configurées pour être insérées dans ladite au moins une rainure (18), **caractérisé en ce que** ledit support de base (15) présente une forme externe qui est sensiblement tronconique par rapport à un axe central (Y), dans lequel un bord annulaire inférieur (27) présente un diamètre externe supérieur au diamètre d'un bord annulaire supérieur (28).
2. Fût (10) selon la revendication 1, **caractérisé en ce que** lesdites parties en saillie (35) réalisées sous la forme d'ailettes sont espacées de manière égale par rapport à un axe central (Y), s'étendant de manière sensiblement rectiligne et inclinée par rapport à un axe central (Y) dudit support de base (15) d'un angle de verrouillage mutuel (β) compris entre 20° et 40°.
3. Fût (10) selon l'une ou l'autre des revendications 1 ou 2, **caractérisé en ce que** lesdites parties en saillie (35) sont flexibles par rapport à une extrémité contrainte (35b) de celles-ci et sont associées à des ouvertures arrière respectives (36) réalisées dans ledit berceau de confinement (16).
4. Fût (10) selon l'une quelconque des revendications précédentes, **caractérisé en ce que** lesdites parties saillantes (35) sont capables de venir en butée avec au moins une extrémité contrainte (35b) de celles-ci contre un épaulement supérieur (18a) de ladite rainure (18).
5. Fût (10) selon l'une quelconque des revendications précédentes, **caractérisé en ce que** ladite rainure (18) présente une surface de butée centrale (18b) inclinée d'un angle d'assise (α) par rapport à un axe (X) du contenant (11) compris entre 20° et 40°.
6. Fût (10) selon les revendications 2 et 5, **caractérisé en ce que** ledit angle de verrouillage mutuel (β) est sensiblement égal ou légèrement inférieur audit angle d'assise (α).
7. Fût (10) selon l'une quelconque des revendications précédentes, **caractérisé en ce que** ladite paroi de fond (13) présente de manière centrale une extension, c'est-à-dire une partie en saillie (19), configurée pour être insérée dans un trou de fond d'appariement (21) dudit support de base (15).
8. Fût (10) selon la revendication 7, **caractérisé en ce que** ladite partie en saillie (19) est centrée par rapport à un axe (X) dudit contenant (11) et présente une forme qui est cohérente avec la forme et la taille dudit fond de trou (21) et est au moins partiellement insérée dans celui-ci.
9. Fût (10) selon l'une quelconque des revendications précédentes, **caractérisé en ce que** ladite rainure (18) est positionnée dans une zone intermédiaire de ladite paroi de fond arrondie (13), de préférence dans la moitié inférieure de ladite paroi de fond (13).
10. Fût (10) selon l'une quelconque des revendications précédentes, **caractérisé en ce que** lesdits moyens de connexion (17) se développent en continuité avec un bord annulaire supérieur (28) qui délimite ledit berceau de confinement (16) et, dans une condition de couplage entre ledit contenant (11) et ledit support de base (15), ledit bord annulaire supérieur (28) est positionné à l'intérieur de ladite rainure (18).
11. Fût (10) selon l'une quelconque des revendications précédentes, **caractérisé en ce qu'il** comprend un volant de préhension (25) fixé à une paroi supérieure (22) dudit contenant (11) et facultativement également à un embout (23) de celui-ci, et ledit support de base (15) est pourvu au niveau du fond d'une assise de couplage (38) mise en forme pour recevoir le volant de préhension (25) d'un second fût (10).
12. Procédé de production d'un fût (10) pour liquides selon l'une quelconque des revendications précédentes, comprenant :
 - une étape d'alimentation d'un contenant (11) comprenant une paroi de fond au moins partiellement arrondie (13) munie circonférentiellement de moyens d'ancrage (14) ;
 - une étape de fourniture d'un support de base (15) présentant une forme externe qui est sensiblement tronconique par rapport à un axe central (Y), dans lequel un bord annulaire inférieur (27) présente un diamètre externe supérieur au diamètre d'un bord annulaire supérieur (28) et comprenant un berceau de confinement (16)

ayant une forme s'appariant au moins partiellement à ladite paroi de fond (13) et pourvu de moyens de connexion stables (17), bien que pouvant être déconnectés ;

- une étape de couplage réciproque entre lesdits moyens de connexion (17) et lesdits moyens d'ancrage (14) afin de générer une connexion et un couplage stable, bien que réversible et amovible, de même forme du type auto-bloquant ou à encliquetage entre ledit contenant (11) et ledit support de base (15). 5
10

13. Procédé selon la revendication 12, **caractérisé en ce que** lesdits moyens d'ancrage (14) sont du type en retrait et comprennent une rainure (18) et lesdits moyens de connexion (17) sont du type en saillie et sont réalisés en continuité avec un bord supérieur (28) dudit support de base (15), et ledit procédé prévoit d'insérer lesdits moyens de connexion (17) dans ladite rainure (18) de manière à ce que ledit bord supérieur (28) soit disposé au moins partiellement à l'intérieur de ladite rainure (18) et venant en butée contre un épaulement supérieur (18a). 15
20

14. Procédé selon la revendication 12 ou 13, **caractérisé en ce qu'il** prévoit d'insérer une partie saillante (19) dudit contenant (11) qui s'étend à partir de ladite paroi de fond (13) à l'intérieur d'un trou de fond d'appariement (21) dudit support de base (15) de manière à aligner ledit conteneur (11) et ledit support de base (15) le long d'un axe commun (X). 25
30

35

40

45

50

55

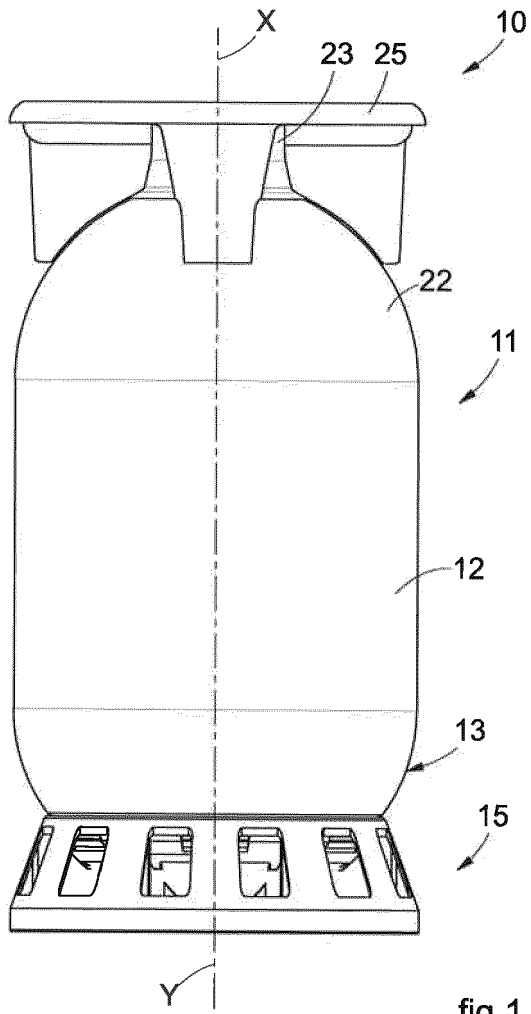

fig.1

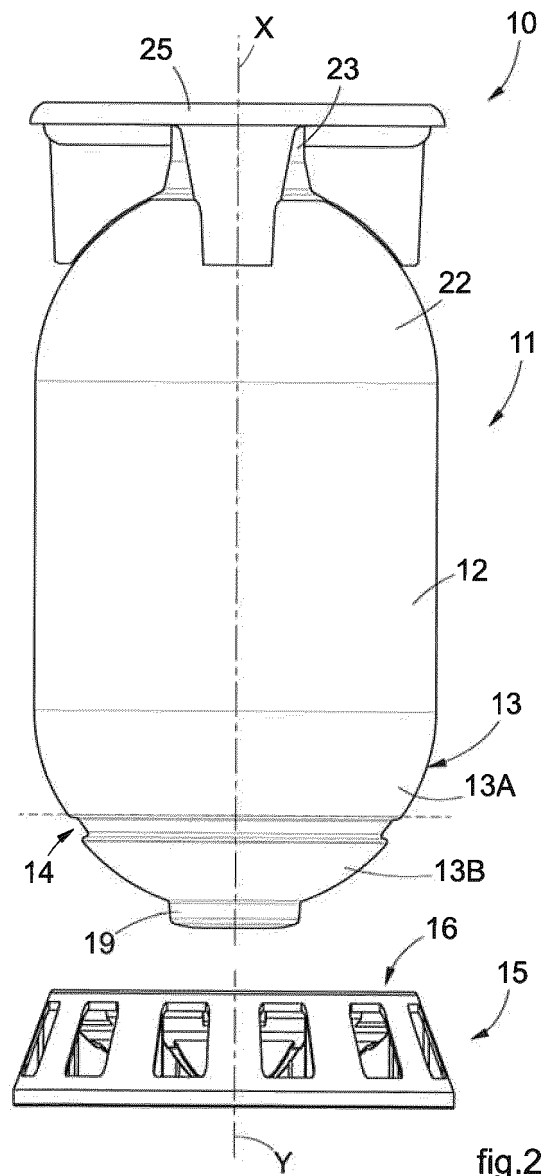
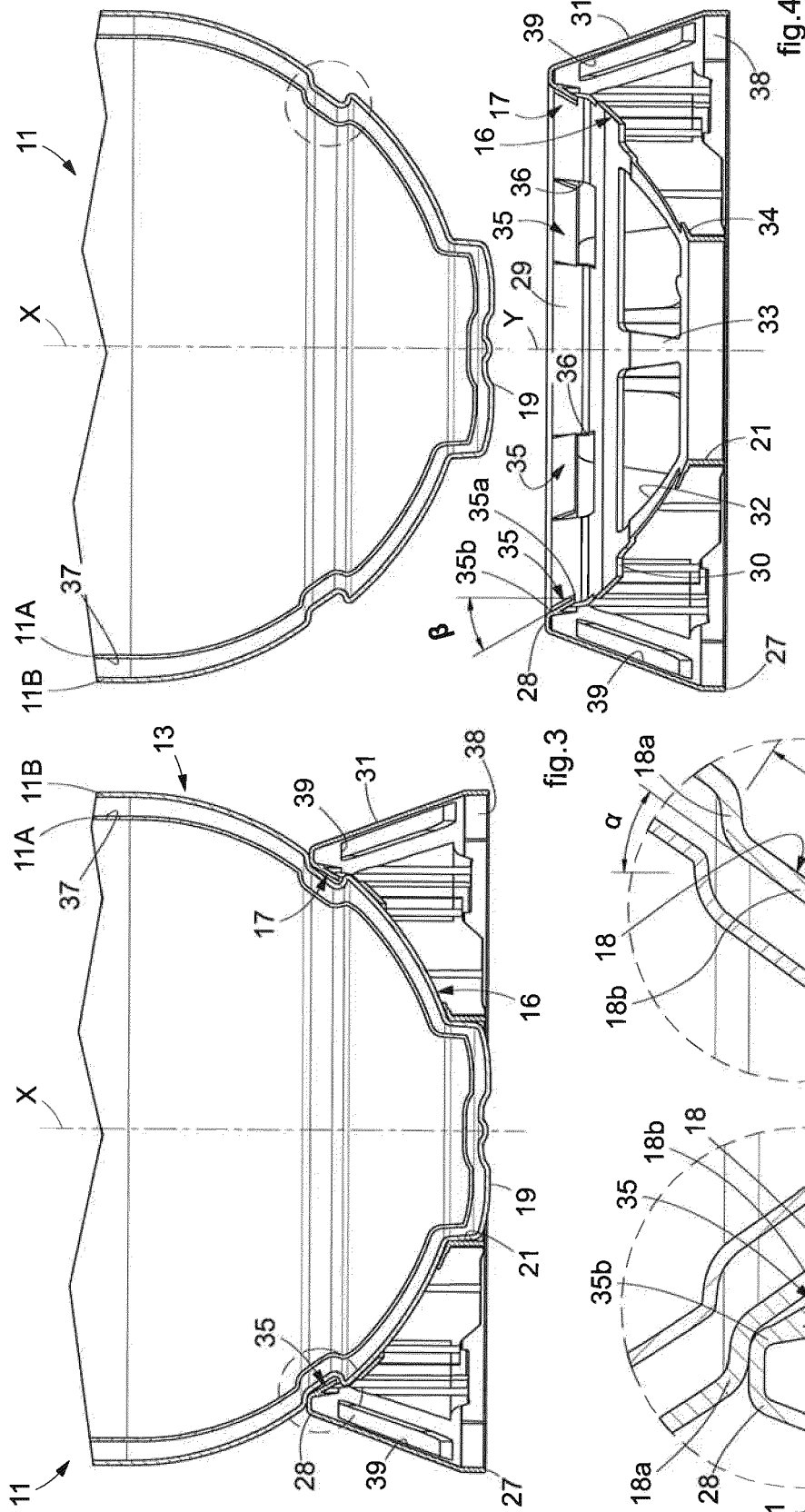

fig.2



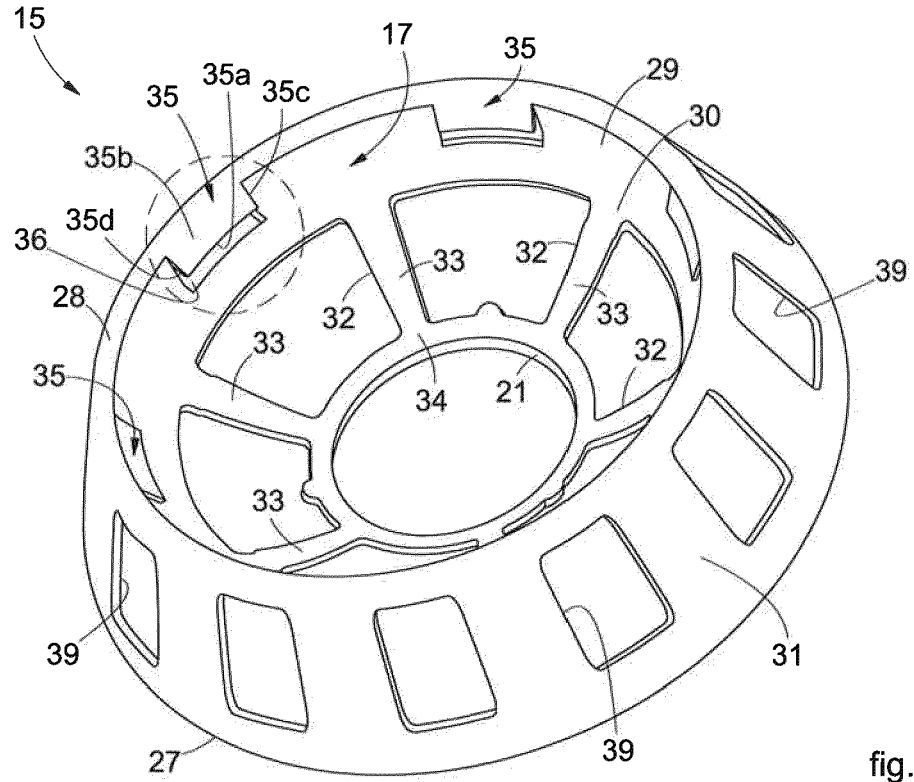

fig.5

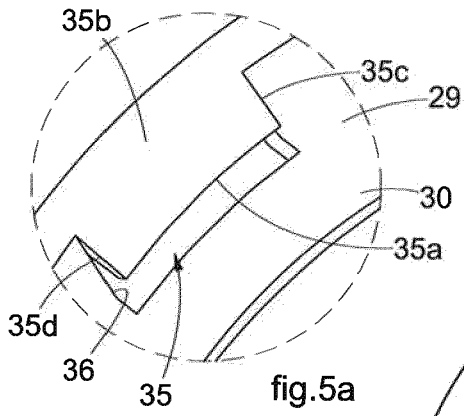

fig.5a

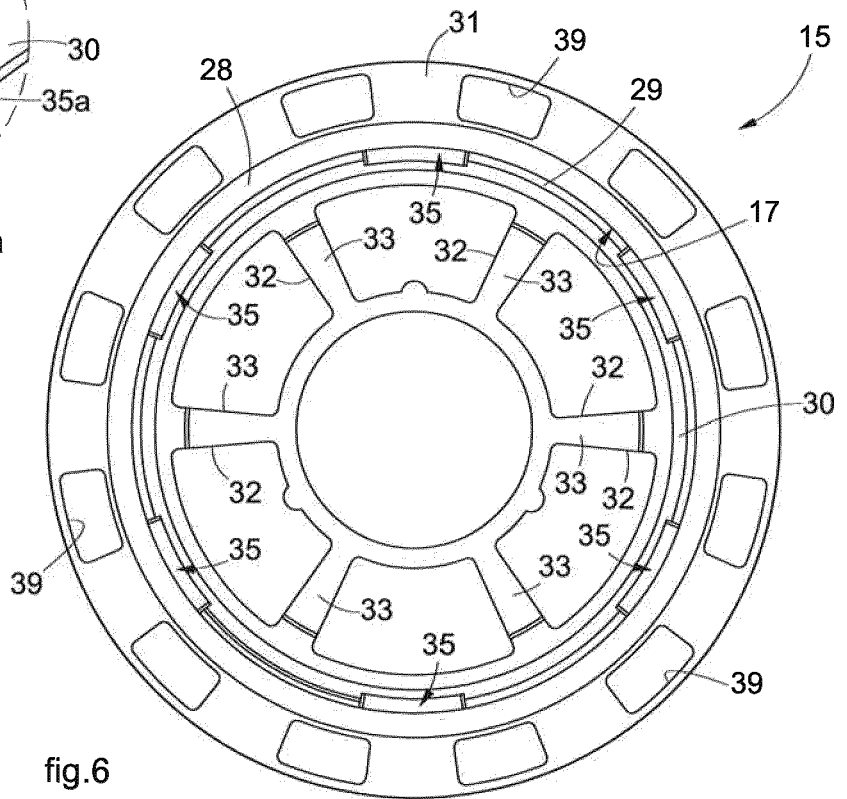

fig.6

REFERENCES CITED IN THE DESCRIPTION

This list of references cited by the applicant is for the reader's convenience only. It does not form part of the European patent document. Even though great care has been taken in compiling the references, errors or omissions cannot be excluded and the EPO disclaims all liability in this regard.

Patent documents cited in the description

- US 6662963 B1 [0012]
- WO 2011143724 A1 [0012]
- US D912520 A [0012]