

(19)



(11)

EP 4 101 649 B1

(12)

EUROPEAN PATENT SPECIFICATION

(45) Date of publication and mention of the grant of the patent:

04.09.2024 Bulletin 2024/36

(21) Application number: **22177358.3**

(22) Date of filing: **06.06.2022**

(51) International Patent Classification (IPC):

B41J 2/165^(2006.01) B41J 3/407^(2006.01)

(52) Cooperative Patent Classification (CPC):

**B41J 2/165; B41J 2/16517; B41J 2/16526;
B41J 2/16529; D06B 11/0023; B41J 3/4078;
B41J 2002/16573**

(54) LIQUID DISCHARGE APPARATUS AND LINEAR-MEDIUM PROCESSING SYSTEM

FLÜSSIGKEITSAUSSTOSSVORRICHTUNG UND LINEARMEDIUMVERARBEITUNGSSYSTEM

APPAREIL D'ÉVACUATION DE LIQUIDE ET SYSTÈME DE TRAITEMENT À SUPPORT LINÉAIRE

(84) Designated Contracting States:

**AL AT BE BG CH CY CZ DE DK EE ES FI FR GB
GR HR HU IE IS IT LI LT LU LV MC MK MT NL NO
PL PT RO RS SE SI SK SM TR**

(30) Priority: **08.06.2021 JP 2021096009**

(43) Date of publication of application:

14.12.2022 Bulletin 2022/50

(73) Proprietor: **Ricoh Company, Ltd.**

Tokyo 143-8555 (JP)

(72) Inventors:

- **OMURA, Taito**
Tokyo 143-8555 (JP)

- **TAKAGI, Yasunobu**
Tokyo 143-8555 (JP)

- **TANAKA, Shinya**
Tokyo 143-8555 (JP)

(74) Representative: **J A Kemp LLP**

**80 Turnmill Street
London EC1M 5QU (GB)**

(56) References cited:

**US-A1- 2006 109 300 US-A1- 2013 182 034
US-A1- 2013 182 035 US-A1- 2017 203 570**

EP 4 101 649 B1

Note: Within nine months of the publication of the mention of the grant of the European patent in the European Patent Bulletin, any person may give notice to the European Patent Office of opposition to that patent, in accordance with the Implementing Regulations. Notice of opposition shall not be deemed to have been filed until the opposition fee has been paid. (Art. 99(1) European Patent Convention).

Description

[0001] Embodiments of the present invention relate to a liquid discharge apparatus and a linear-medium processing system.

Related Art

[0002] Japanese Unexamined Patent Application Publication No. 2018-144337 discloses a droplet discharge device that includes a droplet discharge unit that performs discharge control so that droplets of an amount based on image data are discharged from nozzles onto positions on a medium corresponding to pixel positions of image data, and a recording unit that records the number of times droplet discharge control has been performed for each of at least some of a plurality of nozzles. The droplet discharge unit performs discharge control so that a larger amount of droplets than the amount based on the image data are discharged to positions on the medium corresponding to pixel positions of the image data on which discharge control is performed so that droplets are discharged from nozzles on which discharge control is performed less than N times among at least some of the nozzles.

[0003] US 2013/0182034 A1 discloses a liquid ejection apparatus. US 2017/0203570 A1 discloses a liquid ejection apparatus, an inkjet system and a flushing method.

[0004] An aim of the present invention is to provide a liquid discharge apparatus capable of efficiently discharging liquid.

[0005] According to an aspect of the present invention, there is provided a liquid discharge apparatus as defined in claim 1.

[0006] According to the present invention, there can be provided a liquid discharge apparatus capable of efficiently discharging liquid.

[0007] The aforementioned and other aspects, features, and advantages of the present disclosure would be better understood by reference to the following detailed description when considered in connection with the accompanying drawings, wherein:

FIG. 1 is a schematic view of a linear-medium processing system according to an embodiment of the present invention;

FIG. 2 is a schematic configuration diagram of a liquid discharge unit according to an embodiment of the present invention;

FIG. 3 is a schematic view of nozzle surfaces of liquid discharge heads;

FIGS. 4A, 4B, and 4C are illustrations of head positions in a head movement direction;

FIG. 5 is a schematic view of an example of a discharge sensor;

FIG. 6 is an illustration of overlapping discharge on a linear medium;

FIG. 7 is a graph illustrating the relationship between

nozzle position and thickening speed;

FIGS. 8A, 8B, and 8C are conceptual diagrams of droplet number distribution;

FIGS. 9A and 9B are diagrams illustrating an example of a droplet-count distribution table;

FIG. 10 is a block diagram of hardware of an embroidery system according to an embodiment of the present invention;

FIG. 11 is a flowchart of a process from print image determination to droplet discharge; and

FIG. 12 is a flowchart of a determination process of a droplet-count distribution table.

[0008] The accompanying drawings are intended to depict embodiments of the present disclosure and should not be interpreted to limit the scope thereof. The accompanying drawings are not to be considered as drawn to scale unless explicitly noted.

[0009] In describing embodiments illustrated in the drawings, specific terminology is employed for the sake of clarity. However, the disclosure of this patent specification is not intended to be limited to the specific terminology so selected and it is to be understood that each specific element includes all technical equivalents that operate in a similar manner and achieve similar results.

[0010] Although the embodiments are described with technical limitations with reference to the attached drawings, such description is not intended to limit the scope of the disclosure and all of the components or elements described in the embodiments of this disclosure are not necessarily indispensable. The scope of the invention is defined by the claims.

[0011] Referring now to the drawings, embodiments of the present disclosure are described below. In the drawings for explaining the following embodiments, the same reference codes are allocated to elements (members or components) having the same function or shape and redundant descriptions thereof are omitted below.

[0012] Embodiments of the present invention will be described below with reference to the drawings.

[0013] FIG. 1 is a schematic view of a linear-medium processing system according to an embodiment of the present invention.

[0014] Here, an embroidery system 100 is illustrated as an example of a linear-medium processing system. The embroidery system 100 includes a supply reel 102, a liquid discharge unit 103, a drying unit 104, a post-processing unit 105, and an embroidery unit 106.

[0015] The supply reel 102 holds an embroidery thread 101 (hereinafter referred to as a thread) and supplies the thread 101 to the liquid discharge unit 103. Rollers 108 and 109 are disposed between the supply reel 102 and the liquid discharge unit 103. The roller 109 is provided with a rotary encoder 405. The rotary encoder 405 includes an encoder wheel 405b disposed coaxially with the roller 109 and an encoder sensor 405a to read an encoder slit of the encoder wheel 405b. The feed state of the thread 101 is detected by the rotary encoder 405.

[0016] The liquid discharge unit 103 includes liquid discharge heads 1 (hereinafter referred to as heads) and maintenance units 2. The heads 1 apply liquid to the thread 101 passing below the heads 1. In the present embodiment, the head 1 is a head employing an inkjet recording method, and the liquid applied to the thread 101 is mainly colored ink. Each of the maintenance units 2 includes, for example, a dummy-discharge receiving section, a wiping section, and a suction section. When the head 1 is placed at a position corresponding to each section, the section performs processing on the head 1 and maintains the liquid discharging performance of the head 1.

[0017] The drying unit 104 includes a heater, and heats and dries the thread 101 after ink application. Thus, the thread 101 is dyed in a desired color.

[0018] The post-processing unit 105 includes a cleaner and a lubricant applicator to adjust the state of the thread 101. The cleaner drops a coloring material remaining without being fixed to the thread 101 to clean the thread 101. The lubricant applicator applies lubricant such as wax to the surface of the thread 101.

[0019] The embroidery unit 106 includes an embroidery head, and sews the dyed thread 101 into a cloth to embroider a pattern such as a design or a pattern on the cloth.

[0020] In the above-described configuration, the rotary encoder 405 detects the feed speed of the thread 101 taken in by the embroidery unit 106, and the liquid discharge unit 103 controls ink discharge from the heads 1 in accordance with the feed speed of the thread 101. That is, when the feed speed of the thread 101 taken in by the embroidery unit 106 is slow, the frequency at which ink is discharged onto the thread 101 is lowered. When the feed speed of the thread 101 taken in by the embroidery unit 106 is high, the frequency at which ink is discharged onto the thread 101 is increased. Accordingly, the liquid discharge unit 103 can dye the thread 101 in synchronization with the feed speed of the thread 101 taken in by the embroidery unit 106.

[0021] When the thread 101 is dyed, a wide range of colors can be expressed by combining respective colors (e.g., black, cyan, magenta, and yellow) as in the case where printing is performed on a sheet of paper by an inkjet printer.

[0022] Here, the thread 101 is an example of a linear medium. Examples of the "thread" include glass fiber thread; wool thread; cotton thread; synthetic fiber thread; metallic thread; mixed thread of wool, cotton, polymer, or metal; and linear object to which yarn, filament, or liquid can be applied. Examples of the "thread" also include braided cord and flatly braided cord.

[0023] In addition to the linear object, examples of the "thread" further include band-shaped members (continuous base materials) such as rope, cable, and cord to which liquid can be applied, as discharge receive media that can be colored by droplets. Each of the discharge receive media is a linear or band-shaped medium having

a narrow width and being continuous in the feed direction.

[0024] Note that the linear-medium processing system is not limited to the embroidery system 100. For example, instead of the embroidery unit 106, another processing device such as a weaving machine or a sewing machine may be disposed at a subsequent stage of the post-processing unit 105. In addition, in a case where the embroidery unit is installed at a different location (in a case where the embroidery unit is not an inline type), a winding unit that winds a thread after dyeing may be disposed at a subsequent stage of the post-processing unit 105 instead of the embroidery unit 106. In this case, the thread once wound is carried to the installation location of the processing device and loaded into the processing device, and thus desired processing is performed on the thread.

[0025] FIG. 2 is a diagram illustrating a schematic configuration of a liquid discharge unit according to an embodiment of the present invention, and supplements the description of the liquid discharge unit 103 illustrated in FIG. 1.

[0026] The liquid discharge unit 103 includes a plurality of heads 1a, 1b, 1c, and 1d arranged in a column along the thread feed direction. The heads 1a to 1d are heads that discharge ink of different colors. For example, the head 1a is a head that discharges ink droplets of black (K), the head 1b is a head that discharges ink droplets of cyan (C), the head 1c is a head that discharges ink droplets of magenta (M), and the head 1d is a head that discharges ink droplets of yellow (Y).

[0027] Note that the above-described order of colors is an example, and the colors may be arranged in a different order. The number of heads is not limited to four, and the number of heads may be increased or decreased according to the number of colors to be used in the heads.

[0028] An environment sensor 514 is provided between the head 1b and the head 1c, and the environment sensor 514 detects the temperature and humidity in the vicinity of the nozzles of the heads 1.

[0029] The installation location of the environment sensor 514 is an example, and the environment sensor 514 may be disposed, for example, on the right side of each of the heads 1a to 1d.

[0030] The liquid discharge unit 103 also includes a plurality of maintenance units 2a, 2b, 2c, and 2d below the heads 1a, 1b, 1c, and 1d across the feed path of the thread 101. Each of the maintenance units 2a, 2b, 2c, and 2d includes, for example, a dummy-discharge receiving section, a wiping section, and a suction section and performs each processing on the corresponding one of the heads 1a, 1b, 1c, and 1d placed at the position corresponding to each section.

[0031] FIG. 3 is a schematic view of nozzle surfaces of the liquid discharge heads and is a bottom view of the heads 1 of the liquid discharge unit 103 viewed from below.

[0032] The heads 1a, 1b, 1c, and 1d in the liquid discharge unit 103 include nozzle surfaces 12 facing the thread 101. The nozzle surface 12 of each of the heads

1a, 1b, 1c, and 1d includes two nozzle rows 10a and 10b. Each of the nozzle rows 10a and 10b includes a group of aligned nozzles in which a plurality of nozzles 11 (eight nozzles in this example) are aligned in the thread feed direction. Here, the nozzle 11 is an example of a liquid discharge port, and the nozzle surface 12 is an example of a liquid discharge surface.

[0033] The nozzle row 10a and the nozzle row 10b are disposed in parallel with the thread feed direction and apart from each other at a predetermined interval in a direction (head movement direction) orthogonal to the thread feed direction. When the thread 101 is dyed, the heads 1a, 1b, 1c, and 1d are moved so that the nozzle row 10a or the nozzle row 10b of the heads 1a, 1b, 1c, and 1d is positioned directly above the thread 101. Accordingly, the heads 1a, 1b, 1c, and 1d discharge ink to the thread 101 moving in the thread feed direction to apply ink to the thread 101. FIG. 3 illustrates a case where the thread 101 is dyed using the nozzle row 10a.

[0034] The nozzle row 10a and the nozzle row 10b move the heads 1a, 1b, 1c, and 1d in the head movement direction and replace the nozzle row 10a and the nozzle row 10b with respect to the thread 101 when a predetermined timing obtained from the use time, the ink discharge amount, or the like is reached.

[0035] FIGS. 4A, 4B, and 4C are illustrations of head positions in the head movement direction.

[0036] The liquid discharge unit 103 includes the maintenance unit 2 below the head 1 across the feed path of the thread 101. The maintenance unit 2 includes a suction cap 21 at an upper portion thereof, and the suction cap 21 is movable forward and backward with respect to the maintenance unit 2 (e.g., movable in the directions indicated by arrow A in FIG. 4A). Thus, the suction cap 21 can be brought into contact with and separated from the nozzle surface of the head 1.

[0037] The maintenance unit 2 further includes a discharge sensor 513 at an upper portion thereof. The discharge sensor 513 detects whether the nozzle row 10a (or the nozzle row 10b) of the head 1 is discharging ink droplets. The discharge sensor 513 will be described below in detail with reference to FIG. 5.

[0038] The head 1 located above the maintenance unit 2 is movable in the head movement direction with respect to the maintenance unit 2. FIG. 4A illustrates a state in which the nozzle row 10a of the head 1 is positioned directly above the thread 101, and the nozzle row 10a discharges ink toward the thread 101 to dye the thread 101. FIG. 4B illustrates a state in which the nozzle row 10b of the head 1 is positioned directly above the thread 101, and the nozzle row 10b discharges ink toward the thread 101 to dye the thread 101.

[0039] FIG. 4C illustrates a state in which the head 1 is located at a position facing the suction cap 21. When the head 1 moves to the position facing the suction cap 21, the suction cap 21 moves toward the head 1 (e.g., rises in the present embodiment) and covers (caps) the nozzle surface of the head 1 to prevent drying of the

nozzle surface. The suction cap 21 performs suction with respect to the nozzle in a state in which the nozzle surface is capped with the suction cap 21, thus preventing discharge failure due to ink clogging of the nozzles.

[0040] In addition to the suction cap 21, the maintenance unit 2 includes, for example, a wiping section and a dummy-discharge receiving section. The wiping unit includes a wiper member that wipes the nozzle surface of the head 1 while moving relative to the nozzle surface in the head movement direction. The dummy-discharge receiving section includes a collection container. When dummy discharge (idle discharge) is performed with respect to a nozzle that is not used to apply ink to the thread 101, the collection container receives ink discharged from the nozzle.

[0041] FIG. 5 is a schematic view of an example of the discharge sensor.

[0042] The discharge sensor 513 is located below the head 1 and includes a light emitter 513a and a light receiver 513b. The light emitter 513a includes, for example, a semiconductor laser that emits laser light, and the light receiver 513b includes an optical sensor that receives the laser light from the light emitter 513a and outputs a signal indicating a light receiving state.

[0043] In the above-described configuration, before an operation of discharging ink to the thread 101 is started, the operation of discharging ink droplets is sequentially performed from each nozzle 11 (in this example, from the eight nozzles of 1ch to 8ch) of the nozzle row 10a (or the nozzle row 10b) of the head 1. Among the arrows illustrated at the positions of the nozzles of 1ch to 8ch in FIG. 5, arrows illustrated by solid lines indicate that ink droplets are correctly discharged, and arrows illustrated by broken lines indicate that ink droplets are not discharged.

[0044] Since the nozzles of 1ch and 2ch among the eight nozzles (eight channels) do not discharge ink droplets, there is no change in the laser light detected by the light receiver 513b, and the discharge sensor 513 does not detect ink droplets.

[0045] Since the nozzles of 3ch to 8ch discharge ink droplets, each ink droplet sequentially enters the laser light of the discharge sensor 513 and momentarily blocks the optical path. Accordingly, the light receiver 513b detects that the ink droplet has crossed the laser light, and the discharge sensor 513 detects the discharge of the ink droplet.

[0046] As described above, it is checked whether a non-discharge nozzle is present before the operation of discharging ink to the thread 101 is started. When a non-discharge nozzle is present, dyeing of the thread 101 is not started, and for example, dummy discharge is performed by the maintenance unit 2 to bring about a state in which ink can be discharged.

[0047] FIG. 6 is an illustration of overlapping discharge on a linear medium.

[0048] The thread 101 moves in the thread feed direction along the nozzle row 10a of the head 1. The nozzles

11 discharge ink droplets to the thread 101 moving in the thread feed direction to dye the thread 101 in a desired color.

[0049] In dyeing, ink droplets are overlappingly discharged onto one pixel to be dyed (hereinafter referred to as a target pixel) to express a desired density (e.g., gradation). For example, in a case where the target pixel is to be expressed at a density of 100%, all the nozzles 11 of the nozzle row 10a are used, and one-hundred droplets of ink are discharged from each nozzle 11 (i.e., ink droplets are discharged one-hundred times from each nozzle 11). In a case where the target pixel is expressed by a density of 50%, fifty droplets of ink are discharged from each nozzle 11 of the nozzle row 10a (i.e., ink droplets are discharged fifty times from each nozzle 11).

[0050] That is, in the present embodiment, the pixel forms a unit of an area where ink droplets are overlappingly discharged for gradation expression. In this way, the number of ink droplets to be overlappingly discharged for the target pixel is determined according to the density (gradation) to be expressed.

[0051] Therefore, when the target pixel is expressed with a low density, as illustrated in FIG. 6, some of the nozzles 11 of the nozzle row 10a may be sufficient without using all of the nozzles 11 of the nozzle row 10a.

[0052] As described above, when the number of nozzles to be used varies depending on the gradation to be expressed, the nozzles that are not used are likely to dry, and discharge failure due to ink clogging of the nozzles is likely to occur. In addition to the frequency of use of the nozzles, the ease of drying (thickening speed) of the ink varies depending on the environment around the head. Hereinafter, the relationship between the nozzle position and the dryness of ink (thickening speed) will be described.

[0053] FIG. 7 is a graph illustrating the relationship between the nozzle position and the thickening speed. In order to simplify the description, the number of nozzles 11 in the nozzle row 10a (or the nozzle row 10b) is six (six channels).

[0054] For the heads 1 of the liquid discharge unit 103, the thickening speed of ink in each nozzle may be different depending on the nozzle position even in the same head due to, for example, the influence of air flow around the head, temperature and humidity unevenness, and the structure of the ink flow path inside the head.

[0055] FIG. 7 illustrates an example of a case where the thickening speed tends to be higher on the positions close to the first nozzle of the head 1 than on the positions close to the sixth nozzle. In this case, if the total number of droplets to be overlappingly discharged to the target pixel is distributed such that the number of droplets of the first nozzle and the second nozzle is greater than the number of droplets of the third to sixth nozzles, the ink in a state before thickening can be efficiently discharged while being used for dyeing the thread.

[0056] FIGS. 8A, 8B, and 8C are conceptual diagrams of droplet number distribution.

[0057] FIG. 8A is a diagram illustrating an example of a criteria for distributing the number of droplets. The horizontal axis represents the number (position) of each nozzle 11 in the nozzle row 10a (or the nozzle row 10b) of the head 1, and the vertical axis represents the number (count) of discharged droplets.

[0058] This example indicates that a solid image having a density of 100% is formed on the target pixel when 150 droplets are overlappingly discharged from each nozzle onto the target pixel (i.e., droplets are overlappingly discharged from each nozzle onto the target pixel one-hundred fifty times), that is, when the total number of droplets is 900 droplets (150 droplets \times 6 nozzles).

[0059] FIG. 8B is a diagram illustrating a distribution example of the number of discharged droplets in a case where an image having a density of 60% is formed on a target pixel by the head having the tendency of the thickening speed illustrated in FIG. 7.

[0060] The total number of droplets for forming an image having a density of 60% to the target pixel is 540 droplets, and therefore it is sufficient to overlappingly discharge 90 droplets by each of the six nozzles. However, the first nozzle and the second nozzle are in an environment where the first nozzle and the second nozzle are more likely to dry than the other nozzles, and the ink in the first nozzle and the second nozzle is likely to increase in viscosity, which is likely to cause, for example, ink clogging.

[0061] Therefore, in the present embodiment, the number of ink droplets to be discharged is distributed to each nozzle as illustrated in FIG. 8B based on the tendency of the thickening speed illustrated in FIG. 7. For example, the distribution is performed such that the first nozzle having a high thickening speed discharges 150 droplets of ink, the second nozzle discharges 115 droplets of ink, the third to fifth nozzles discharge 75 droplets of ink, and the sixth nozzle discharges 50 droplets of ink.

[0062] FIG. 8C is a diagram illustrating drive waveforms for discharging the number of droplets distributed in FIG. 8B from each nozzle. The drive waveforms of the second nozzle and the subsequent nozzles are generated by electrically performing a masking process based on the drive waveform of the first nozzle and the ratio of the number of droplets to be discharged.

[0063] FIGS. 9A and 9B are diagrams illustrating an example of a droplet-count distribution table. FIG. 9A is a diagram illustrating the relationship between the ratio of the number of droplets to be discharged and the nozzle position. FIG. 9B is a diagram illustrating the relationship between the number of discharged droplets and the nozzle position.

[0064] In the distribution of the number of ink droplets, a plurality of droplet-count distribution tables are prepared in advance in the control unit 500 to be described below, and the droplet-count distribution table is selected based on the use environment information acquired before the start of the ink discharge operation.

[0065] For example, assume the case of a head having

a characteristic that the head dries more easily from the center of the nozzle row toward both ends. It is also assumed that the total number of droplets to be overlappingly discharged onto one pixel (target pixel) determined from the gradation is 600. In this case, as illustrated in FIG. 9A, the control unit 500 selects the droplet-count distribution table in which the ratio of the number of droplets to be discharged increases from the third nozzle and the fourth nozzle in the central portion toward both end portions. Thus, the number of droplets of each nozzle is determined as illustrated in FIG. 9B.

[0066] FIG. 9B illustrates an example in which 600 droplets of ink are overlappingly discharged onto the target pixel, and 150 droplets of ink are overlappingly discharged by each of the first nozzle and the sixth nozzle positioned at both ends of the nozzle row. In addition, each of the second nozzle and the fifth nozzle overlappingly discharges 100 droplets, and each of the third nozzle and the fourth nozzle overlappingly discharges 50 droplets. Thus, the overlapping discharge of 600 droplets of ink onto the target pixel is completed.

[0067] As described above, in the present embodiment, the nozzles at the end portions that are weak against drying discharge more droplets than the nozzles at the central portion. Accordingly, the head as a whole is strong against drying, thus allowing a reduction in the execution frequency of dummy discharge in the maintenance unit 2.

[0068] As in the above-described example, when the total number of droplets (600 droplets) of ink to be overlappingly discharged is equal to or greater than the number of nozzles (six), the selected droplet-count distribution table is a droplet-count distribution table in which the number of times of droplet discharge is distributed such that each nozzle discharges ink once or more.

[0069] By contrast, there may be a case where the total number of ink droplets to be overlappingly discharged is smaller than the number of nozzles (in the above example, a case where the total number of ink droplets is 5 or less), such as a case where an extremely light color (low density) is expressed in gradation in a target pixel. In this case, the selected droplet-count distribution table is a droplet-count distribution table in which the number of times of droplet discharge is distributed by giving priority to nozzles that have not been used in ink discharge for the immediately preceding pixel.

[0070] FIG. 10 is a block diagram of hardware of an embroidery system according to an embodiment of the present invention.

[0071] The control unit 500 controls the entire embroidery system 100. The control unit 500 includes a central processing unit (CPU) 501, a read only memory (ROM) 502, a random access memory (RAM) 503, a non-volatile RAM (NVRAM) 504, and an application specific integrated circuit (ASIC) 505. The control unit 500 includes an interface (I/F) 506, a head drive controller 507, a carriage controller 508, and a data bus 509.

[0072] The CPU 501 controls the entire operation that

also controls the movement operations of the heads 1a, 1b, 1c, and 1d. The CPU 501 reads the program and data stored in the ROM 502 from the ROM 502 to the RAM 503 and executes the processing.

[0073] The ROM 502 is a non-volatile semiconductor memory and stores programs executed by the CPU 501 and other fixed data (e.g., basic input output system (BIOS), operating system (OS) setting, and network setting). The RAM 503 is a volatile semiconductor memory and temporarily stores programs and data. The NVRAM 504 is a rewritable non-volatile semiconductor memory and enables data retention when the power supply of the apparatus is cut off.

[0074] The ASIC 505 processes various signal processing, image processing such as sorting, and other input-and-output signals for controlling the entire apparatus. The I/F 506 transmits and receives signals to and from a host such as a personal computer (PC) 510.

[0075] The head drive controller 507 includes droplet-count distribution tables 507a and a drive waveform generator 507b. Based on the detection results of the discharge sensor 513 and the environment sensor 514, the head drive controller 507 selects a droplet-count distribution table to be used for dyeing the thread from the droplet-count distribution tables 507a. In addition, the head drive controller 507 generates a drive waveform for driving the heads 1a, 1b, 1c, and 1d with the drive waveform generator 507b based on the selected droplet-count distribution table, and outputs the drive waveform to the head driver 512.

[0076] The carriage controller 508 drives a carriage motor 31. An operation panel 511 inputs and displays information. The head driver 512 discharges ink droplets from the heads 1a, 1b, 1c, and 1d based on an instruction from the head drive controller 507.

[0077] The discharge sensor 513 detects whether ink droplets have been discharged from the nozzles 11 of the heads 1a, 1b, 1c, and 1d, and outputs the detection result to the control unit 500. The environment sensor 514 detects temperatures and humidities near the nozzles of the heads 1a, 1b, 1c, and 1d, and outputs the detection results to the control unit 500.

[0078] The carriage motor 31 moves a carriage 30 based on an instruction from the carriage controller 508. The rotary encoder 405 detects a feed state of the thread 101 and outputs a detection result to the control unit 500.

[0079] The carriage 30 holds the heads 1a, 1b, 1c, and 1d. When the carriage 30 moves in the head movement direction illustrated in FIG. 4, the heads 1a, 1b, 1c, and 1d can move to the position facing the thread 101, the position facing the suction cap 21, and the like. The number of carriages 30 is not limited to one. For example, a carriage may be provided individually for each head, and the movement operation in the head movement direction may be performed independently for each head.

[0080] The control unit 500 receives, for example, print data generated by the PC 510 via a cable or a network by I/F 506. The CPU 501 of the control unit 500 reads

and analyzes the print data in a reception buffer disposed in the I/F 506.

[0081] The ASIC 505 performs, for example, image processing and data-sorting processing on the analysis result in the CPU 501. The CPU 501 transmits a processing result in the ASIC 505 to the head drive controller 507, and the head drive controller 507 outputs image data and a drive waveform to the head driver 512 at predetermined timing.

[0082] Dot pattern data for outputting an image may be generated by storing the dot pattern data in, for example, the ROM 502. Alternatively, the host (in this example, the PC 510) may expand the image data into bitmap data and transmit the bitmap data to the embroidery system 100.

[0083] The drive waveform generator 507b included in the head drive controller 507 includes, for example, a digital-to-analog (D/A) converter and an amplifier. The D/A converter converts the pattern data of a drive pulse stored in the ROM 502 into digital data. The drive waveform generator 507b outputs a drive waveform composed of one drive pulse or a plurality of drive pulses to the head driver 512.

[0084] The head driver 512 selectively applies drive pulses constituting a drive waveform from the drive waveform generator 507b to a pressure generator of the head, based on image data corresponding to one line of the head by serial input, to drive the head. The head driver 512 includes, for example, a shift register that inputs a clock signal and image data, a latch circuit that latches a register value of the shift register by a latch signal, a level shifter that changes the level of an output value of the latch circuit, and an analog switch array that controls ON and OFF with the level shifter. Controlling the ON and OFF of the analog switch array causes a predetermined drive pulse included in the drive waveform to be selectively applied to the pressure generating means of the head.

[0085] FIG. 11 is a flowchart of a process from print image determination to droplet discharging.

[0086] First, an image to be printed on the thread 101 is determined (step S1). That is, in step S1, the density (gradation) of each pixel (target pixel) is determined in response to determination of the print image.

[0087] In response to the determination of the gradation, the number of droplets (i.e., the total number of droplets) to be overlappingly discharged in the target pixel is determined (step S2).

[0088] Next, when the total number of overlappingly discharging droplets is determined, the head drive controller 507 selects, from among a plurality of droplet-count distribution tables, a droplet-count distribution table for distributing the number of ink droplets to be discharged from any nozzle and determines the droplet-count distribution table to be used (step S3).

[0089] Then, ink droplets are discharged from each nozzle, based on the ratio of droplets to be discharged in the selected droplet-count distribution table, to dye the

target pixel at a desired gradation (step S4).

[0090] FIG. 12 is a detailed flowchart of a determination process of the droplet-count distribution table (step S3) in the process illustrated in FIG. 11.

5 **[0091]** The droplet-count distribution tables 507a include a plurality of patterns of droplet-count distribution tables created in advance based on use environment information including information on ink thickening speed, information on non-discharge of ink from nozzles, and information on temperature and humidity in the vicinity of nozzles.

10 **[0092]** In each droplet-count distribution table, information on the number of times of discharging ink droplets is set for each nozzle when the use environment information is changed.

15 **[0093]** For example, the information on the thickening speed of ink includes information such as the ease of drying of the nozzle structure in addition to a characteristic value unique to the ink. In addition, the information on the non-discharge of ink from nozzles is information related to nozzles that cannot discharge ink. Furthermore, the information on the temperature and humidity in the vicinity of nozzles is information relating to the ease of drying for each nozzle, which is predicted from airflows inside the apparatus and temperature and humidity un-
20 evenness that are experimentally known in advance.

25 **[0094]** When entering the droplet-count distribution table determination process, first, the head drive controller 507 executes table extraction based on temperature and humidity using the temperature and humidity information detected by the environment sensor 514 (step S31). Thus, the droplet-count distribution table of the pattern corresponding to the temperature and humidity detected by the environment sensor 514 is extracted.

30 **[0095]** Next, the head drive controller 507 executes a non-discharge check based on the discharge information detected by the discharge sensor 513 (step S32). As a result, the head drive controller 507 determines whether ink discharge is possible in the pattern (the ratio of number of droplets to be discharged) of the droplet-count distribution table selected in step S31.

35 **[0096]** Here, if the head drive controller 507 determines that there is a non-discharge nozzle that cannot discharge ink, the maintenance unit 2 performs, for example, an dummy discharge operation to eliminate the non-discharge state of the nozzle.

40 **[0097]** When the head drive controller 507 determines that there is no non-discharge nozzle, the head drive controller 507 checks characteristics of the nozzle structure (step S33).

45 **[0098]** In the heads 1a, 1b, 1c, and 1d, the thickening speed of ink in each nozzle may be different depending on the nozzle position even in the same head due to, for example, the influence of the air flow around the head, the temperature and humidity unevenness, and the structure of the ink flow path in the head. For this reason, in step S33, the value of the droplet-count distribution table selected in step S31 is corrected in consideration of the

characteristics caused by the nozzle structure as described above that may increase the viscosity of the ink. Thus, an optimized droplet-count distribution table can be determined.

[0099] Note that the order of steps S31 to S33 is an example and is not limited to this order. The step S32 does not necessarily need to be performed in the determination process of the droplet-count distribution table, and information acquired in another process such as a process before the start of the ink discharge operation on the thread may be used. The step S33 may be corrected in advance at the stage of storing a droplet-count distribution table into the droplet-count distribution tables 507a instead of being performed in the determination process of the droplet-count distribution table.

[0100] As described above, the liquid discharge apparatus according to the present embodiment includes the nozzle surface 12 having the plurality of nozzles 11 and the control unit 500 that generates a drive waveform and controls ink discharge from the nozzles 11 based on the drive waveform. The control unit 500 includes a plurality of droplet-count distribution tables 507a in which information on the number of droplets to be discharged for each nozzle is set, and forms the drive waveform by using a droplet-count distribution table selected from the plurality of droplet-count distribution tables based on information on the use environment (use environment information) of the nozzles 11 acquired before starting an ink discharge operation.

[0101] Thus, the thickening of the ink in the nozzle 11 and on the nozzle surface 12 can be reduced, and the ink in a state before thickening can be efficiently discharged through the thread 101 while the ink is used for dyeing the thread 101. Since the occurrence of thickened ink can be reduced, the frequency of performing the dummy discharge operation in the maintenance unit 2 can also be reduced, and the amount of ink discarded by the dummy discharge can also be reduced.

[0102] As described above, the droplet-count distribution table 507a is set based on the use environment information of the nozzles 11.

[0103] As described above, the use environment information includes at least one of information on the thickening speed of ink, information on the non-discharge of ink from the nozzles 11, and information on the temperature and humidity in the vicinity of the nozzles 11.

[0104] As a result, the droplet-count distribution table can be optimized in accordance with the liquid discharge apparatus to be used.

[0105] As described above, in a case where ink is overlappingly discharged on the thread 101 and the total number of ink droplets to be overlappingly discharged is equal to or greater than the number of nozzles 11, the selected droplet-count distribution table is a droplet-count distribution table in which the number of times of droplets to be discharged is distributed such that each nozzle 11 discharges ink one or more times.

[0106] As described above, in a case where ink is over-

lappingly discharged on the thread 101 and the total number of ink droplets to be overlappingly discharged is less than the number of nozzles 11, the selected droplet-count distribution table is a droplet-count distribution table in which the number of times of droplets to be discharged is distributed preferentially to nozzles that have not been used in the immediately-preceding overlapping discharge operation, that is, in the overlapping discharge of ink to the immediately preceding pixel.

[0107] Thus, the occurrence of thickened ink in the nozzle 11 can be reduced.

[0108] Although the present embodiment has been described based on an example of an embroidery system, a liquid discharge apparatus according to an embodiment of the present invention is not limited to a linear recording medium such as a thread, and can also be applied to a system that applies liquid to a planar recording medium such as paper or cloth.

[0109] The above-described configurations are examples, and the following aspects of the present invention have, for example, advantageous effects described below.

First aspect

[0110] According to a first aspect, a liquid discharge apparatus (e.g., the embroidery system 100) includes a liquid discharge surface (e.g., the nozzle surface 12) having a plurality of liquid discharge ports (e.g., the nozzles 11), and a control unit (e.g., the control unit 500) that generates a drive waveform and controls discharge of liquid (e.g., ink) from the plurality of liquid discharge ports based on the drive waveform. The control unit includes a plurality of droplet-count distribution tables (e.g., the droplet-count distribution tables 507a) in which information on the number of times of droplets to be discharged for each liquid discharge port is set. The control unit forms the drive waveform by using a droplet-count distribution table selected from the plurality of droplet-count distribution tables, based on use environment information of the plurality of liquid discharge ports acquired before starting a discharge operation of the liquid.

[0111] According to the first aspect, a liquid discharge apparatus capable of efficiently discharging liquid can be provided.

Second aspect

[0112] According to a second aspect, in the first aspect, the droplet-count distribution table (e.g., droplet-count distribution table 507a) is set based on the use environment information of the plurality of liquid discharge ports (e.g., the nozzles 11).

Third aspect

[0113] According to a third aspect, in the first aspect or the second aspect, the use environment information

includes at least one of information on thickening speed of the liquid (e.g., ink), information on non-discharge of the liquid from the plurality of liquid discharge ports (e.g., the nozzles 11), and information on temperature and humidity in the vicinity of the plurality of liquid discharge ports.

[0114] According to the second aspect and the third aspect, the droplet-count distribution table can be optimized in accordance with the liquid discharge apparatus to be used.

Fourth aspect

[0115] According to a fourth aspect, in any one of the first to third aspects, when the liquid (e.g., ink) is overlappingly discharged on a recording medium (e.g., the thread 101) and the total number of droplets of the liquid to be overlappingly discharged is equal to or greater than the number of the plurality of liquid discharge ports (e.g., the nozzles 11), the droplet-count distribution table (e.g., the droplet-count distribution table 507a) selected from the plurality of droplet-count distribution tables is a droplet-count distribution table in which the number of times of droplets to be discharged is distributed so that each liquid discharge port discharges the liquid one or more times.

Fifth aspect

[0116] In a fifth aspect according to any one of the first to third aspects, when the liquid (e.g., ink) is overlappingly discharged on the recording medium (e.g., the thread 101) and the total number of droplets of the liquid to be overlappingly discharged is less than the number of liquid discharge ports (e.g., the nozzles 11), the droplet-count distribution table (e.g., the droplet-count distribution table 507a) selected from the plurality of droplet-count distribution tables is a droplet-count distribution table in which the number of times of droplets to be discharged is distributed preferentially to liquid discharge ports having not been used in the immediately-preceding overlapping discharge operation.

[0117] According to the fourth aspect and the fifth aspect, the occurrence of thickened liquid in the plurality of liquid discharge ports can be reduced.

Claims

1. A liquid discharge apparatus, comprising:

a liquid discharge surface (12) having a plurality of liquid discharge ports (11); and
a control unit (500) configured to generate a drive waveform and control discharge of liquid from the plurality of liquid discharge ports based on the drive waveform,
wherein the control unit (500) includes a plurality

of droplet-count distribution tables (507a) in which information on a number of times of droplets to be discharged from each one of the plurality of liquid discharge ports is set, and wherein the control unit (500) is configured to form the drive waveform based on image data and by using a droplet-count distribution table selected from the plurality of droplet-count distribution tables based on information on a use environment of the plurality of liquid discharge ports acquired before starting a discharge operation of the liquid.

2. The liquid discharge apparatus according to claim 1, wherein the droplet-count distribution table is set based on the information on the use environment of the plurality of liquid discharge ports.

3. The liquid discharge apparatus according to claim 1 or 2, wherein the information on the use environment includes at least one of information on a thickening speed of the liquid, information on non-discharge of the liquid from the plurality of liquid discharge ports, and information on a temperature and humidity in vicinity of the plurality of liquid discharge ports.

4. The liquid discharge apparatus according to any one of claims 1 to 3, wherein when the control unit (500) is configured to control overlapping discharge of the liquid on a recording medium and a total number of droplets of the liquid to be overlappingly discharged is equal to or greater than a number of the plurality of liquid discharge ports, the droplet-count distribution table selected from the plurality of droplet-count distribution tables is a droplet-count distribution table in which the number of times of droplets to be discharged from each one of the plurality of liquid discharge ports is distributed such that each one of the plurality of liquid discharge ports discharges the liquid one or more times.

5. The liquid discharging apparatus according to any one of claims 1 to 3, wherein when the control unit (500) is configured to control overlapping discharge of the liquid on a recording medium and a total number of droplets of the liquid to be overlappingly discharged is smaller than a number of the plurality of liquid discharge ports, the droplet-count distribution table selected from the plurality of droplet-count distribution tables is a droplet-count distribution table in which the number of times of droplets to be discharged from each one of the plurality of liquid discharge ports is distributed preferentially to liquid discharge ports having not been used in an immediately-preceding overlapping discharge operation.

6. A linear-medium processing system (100) for performing processing on a linear recording medium, the system comprising the liquid discharge apparatus according to any one of claims 1 to 5.

Patentansprüche

1. Flüssigkeitsausstoßeinrichtung, umfassend:

eine Flüssigkeitsausstoßoberfläche (12) mit einer Mehrzahl von Flüssigkeitsausstoßdurchlassöffnungen (11); und
 eine Steuereinheit (500), die dazu konfiguriert ist, eine Antriebswellenform zu erzeugen und den Ausstoß von Flüssigkeit aus der Mehrzahl von Flüssigkeitsausstoßdurchlassöffnungen auf Grundlage der Antriebswellenform zu steuern,
 wobei die Steuereinheit (500) eine Mehrzahl von Tröpfchenzahlverteilungstabellen (507a) beinhaltet, in denen Informationen über eine Anzahl von Malen eingestellt sind, die Tröpfchen von jeder der Mehrzahl von Flüssigkeitsausstoßdurchlassöffnungen ausgestoßen werden sollen, und
 wobei die Steuereinheit (500) dazu konfiguriert ist, die Antriebswellenform auf Grundlage von Bilddaten und durch Verwendung einer Tröpfchenzahlverteilungstabelle auszubilden, die aus der Mehrzahl von Tröpfchenzahlverteilungstabellen auf Grundlage von Informationen über eine Verwendungsumgebung der Mehrzahl von Flüssigkeitsausstoßdurchlassöffnungen ausgewählt wird, die vor dem Start eines Ausstoßvorgangs der Flüssigkeit erfasst wurden.

2. Flüssigkeitsausstoßeinrichtung nach Anspruch 1, wobei die Tröpfchenzahlverteilungstabelle auf Grundlage der Informationen über die Verwendungsumgebung der Mehrzahl von Flüssigkeitsausstoßöffnungen eingestellt wird.
3. Flüssigkeitsausstoßeinrichtung nach Anspruch 1 oder 2, wobei die Informationen über die Verwendungsumgebung wenigstens eine von Informationen über eine Verdickungsgeschwindigkeit der Flüssigkeit, Informationen über den Nichtausstoß der Flüssigkeit aus der Mehrzahl von Flüssigkeitsausstoßdurchlassöffnungen und Informationen über eine Temperatur und Feuchtigkeit in der Nähe der Mehrzahl von Flüssigkeitsausstoßdurchlassöffnungen beinhalten.
4. Flüssigkeitsausstoßeinrichtung nach einem der Ansprüche 1 bis 3, wobei die Steuereinheit (500) dazu konfiguriert ist,

den überlappenden Ausstoß von der Flüssigkeit auf ein Aufzeichnungsmedium zu steuern, und die Gesamtzahl der überlappend auszustoßenden Flüssigkeitströpfchen gleich oder größer als eine Anzahl der Mehrzahl von Flüssigkeitsausstoßdurchlassöffnungen ist, die Tröpfchenzahlverteilungstabelle, die aus der Mehrzahl von Tröpfchenzahlverteilungstabellen ausgewählt ist, eine Tröpfchenzahlverteilungstabelle ist, in der die Anzahl der Male, die Tröpfchen aus jeder der Mehrzahl von Flüssigkeitsausstoßdurchlassöffnungen überlappend ausgestoßen werden sollen, derart verteilt ist, dass jede der Mehrzahl von Flüssigkeitsausstoßdurchlassöffnungen die Flüssigkeit ein oder mehrere Male ausstößt.

5. Flüssigkeitsausstoßeinrichtung nach einem der Ansprüche 1 bis 3, wobei, wenn die Steuereinheit (500) dazu konfiguriert ist, den überlappenden Ausstoß von der Flüssigkeit auf ein Aufzeichnungsmedium zu steuern, und eine Gesamtzahl der Tröpfchen der überlappend auszustoßenden Flüssigkeit kleiner ist als eine Anzahl der Mehrzahl von Flüssigkeitsausstoßdurchlassöffnungen, die Tröpfchenzahlverteilungstabelle, die aus der Mehrzahl von Tröpfchenzahlverteilungstabellen ausgewählt ist, eine Tröpfchenzahlverteilungstabelle ist, in der die Anzahl von Malen, die Tröpfchen von jeder der Mehrzahl von Flüssigkeitsausstoßdurchlassöffnungen ausgetragen werden soll, vorzugsweise auf Flüssigkeitsausstoßdurchlassöffnungen verteilt wird, die nicht in einem unmittelbar vorhergehenden überlappenden Ausstoßvorgang verwendet wurden.
6. Verarbeitungssystem (100) für ein lineares Medium zum Durchführen der Verarbeitung auf einem linearen Aufzeichnungsmedium, wobei das System die Flüssigkeitsausstoßeinrichtung nach einem der Ansprüche 1 bis 5 umfasst.

Revendications

1. Appareil à décharge de liquide, comprenant :

une surface de décharge de liquide (12) ayant une pluralité d'orifices de décharge de liquide (11) ; et
 une unité de commande (500) configurée pour générer une forme d'onde de commande et commander la décharge de liquide à partir de la pluralité d'orifices de décharge de liquide sur la base de la forme d'onde de commande, dans lequel l'unité de commande (500) comprend une pluralité de tables de distribution de nombre de gouttelettes (507a) dans lesquelles des informations sur le nombre de fois où les gouttelettes doivent être déchargées depuis

- chacun de la pluralité d'orifices de décharge de liquide sont définies, et dans lequel l'unité de commande (500) est configurée pour former la forme d'onde de commande sur la base de données d'image et en utilisant une table de distribution de nombre de gouttelettes sélectionnée parmi la pluralité de tables de distribution de nombre de gouttelettes sur la base d'informations sur un environnement d'utilisation de la pluralité d'orifices de décharge de liquide acquis avant de commencer une opération de décharge du liquide.
2. Appareil à décharge de liquide selon la revendication 1, dans lequel la table de distribution de nombre de gouttelettes est définie sur la base des informations sur l'environnement d'utilisation de la pluralité d'orifices de décharge de liquide.
3. Appareil à décharge de liquide selon la revendication 1 ou 2, dans lequel les informations sur l'environnement d'utilisation comprennent au moins une information parmi des informations sur une vitesse d'épaississement du liquide, des informations sur la non-décharge du liquide à partir de la pluralité d'orifices de décharge de liquide, et/ou des informations sur une température et une humidité à proximité de la pluralité d'orifices de décharge de liquide.
4. Appareil à décharge de liquide selon l'une quelconque des revendications 1 à 3, dans lequel lorsque l'unité de commande (500) est configurée pour contrôler une décharge superposée du liquide sur un support d'enregistrement et qu'un nombre total de gouttelettes du liquide à décharger de manière superposée est égal ou supérieur à un nombre de la pluralité d'orifices de décharge de liquide, la table de distribution de nombre de gouttelettes sélectionnée parmi la pluralité de tables de distribution de nombre de gouttelettes est une table de distribution de nombre de gouttelettes dans laquelle le nombre de fois où les gouttelettes doivent être évacuées de chacun de la pluralité d'orifices de décharge de liquide est distribué de telle sorte que chacun de la pluralité d'orifices de décharge de liquide décharge le liquide une ou plusieurs fois.
5. Appareil à décharge de liquide selon l'une quelconque des revendications 1 à 3, dans lequel lorsque l'unité de commande (500) est configurée pour contrôler une décharge superposée du liquide sur un support d'enregistrement et qu'un nombre total de gouttelettes du liquide à décharger de manière superposée est inférieur à un nombre de la pluralité d'orifices de décharge de liquide, la table de distribution de nombre de gouttelettes sélectionnée parmi la pluralité de tables de distribution de nombre de gouttelettes est une table de distribution de nombre de gouttelettes dans laquelle le nombre de fois où les gouttelettes doivent être évacuées de chacun de la pluralité d'orifices de décharge de liquide est distribué préférentiellement aux orifices de décharge de liquide n'ayant pas été utilisé dans une opération de déchargement superposée immédiatement précédente.
6. Système de traitement sur support linéaire (100) pour effectuer un traitement sur un support d'enregistrement linéaire, le système comprenant l'appareil à décharge liquide selon l'une quelconque des revendications 1 à 5.

FIG. 1

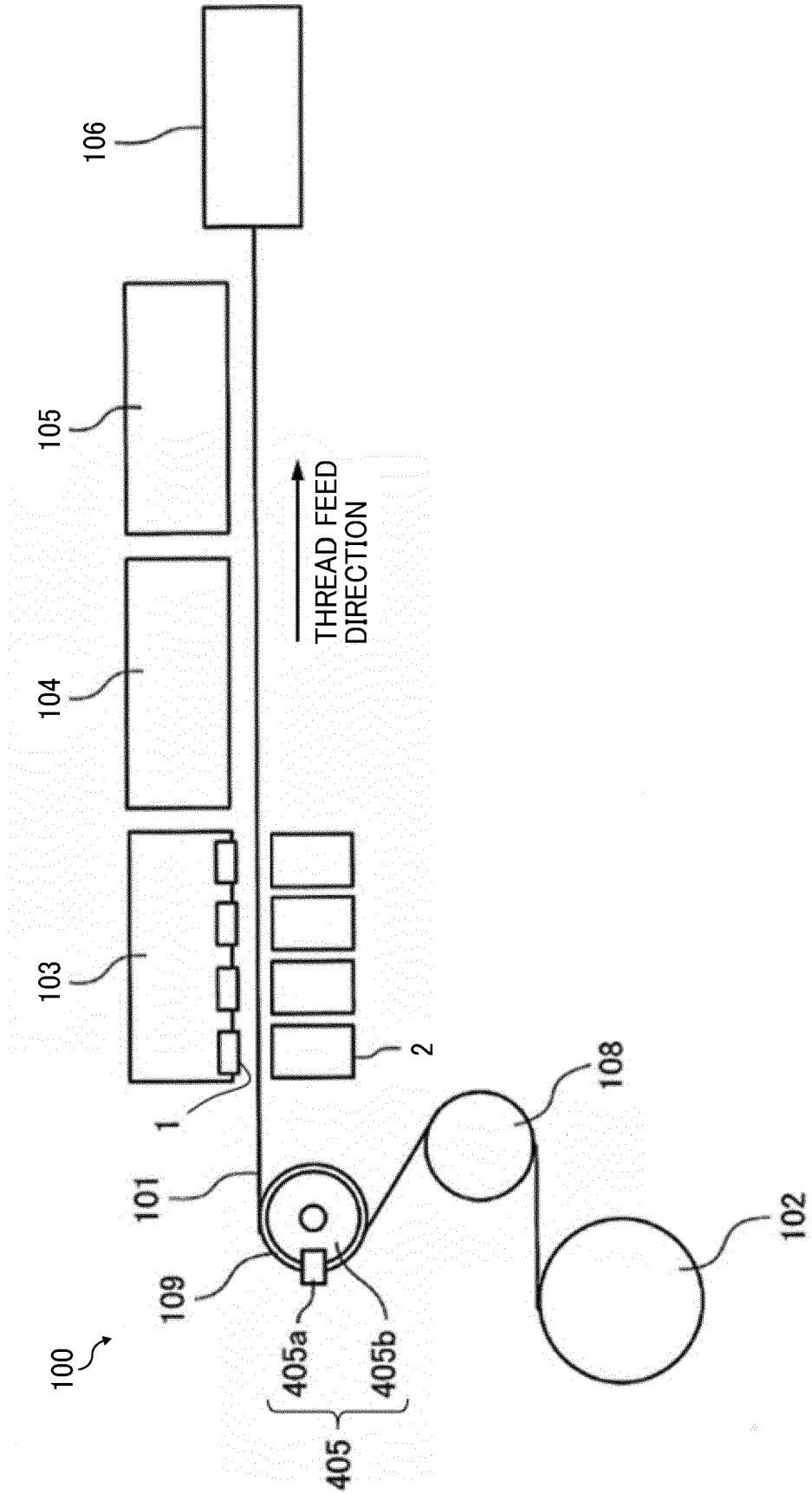

FIG. 2

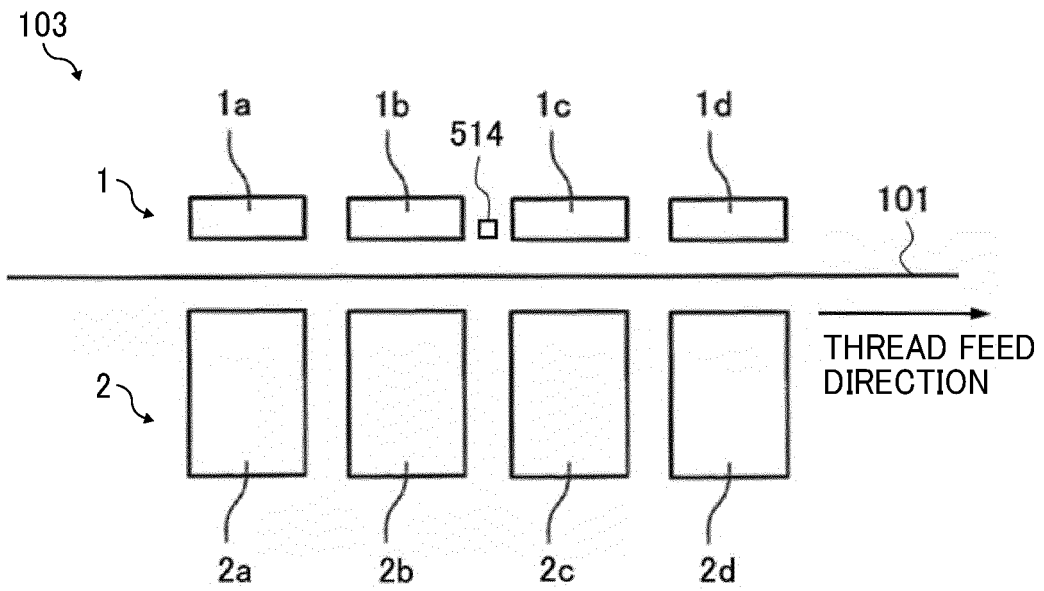

FIG. 3

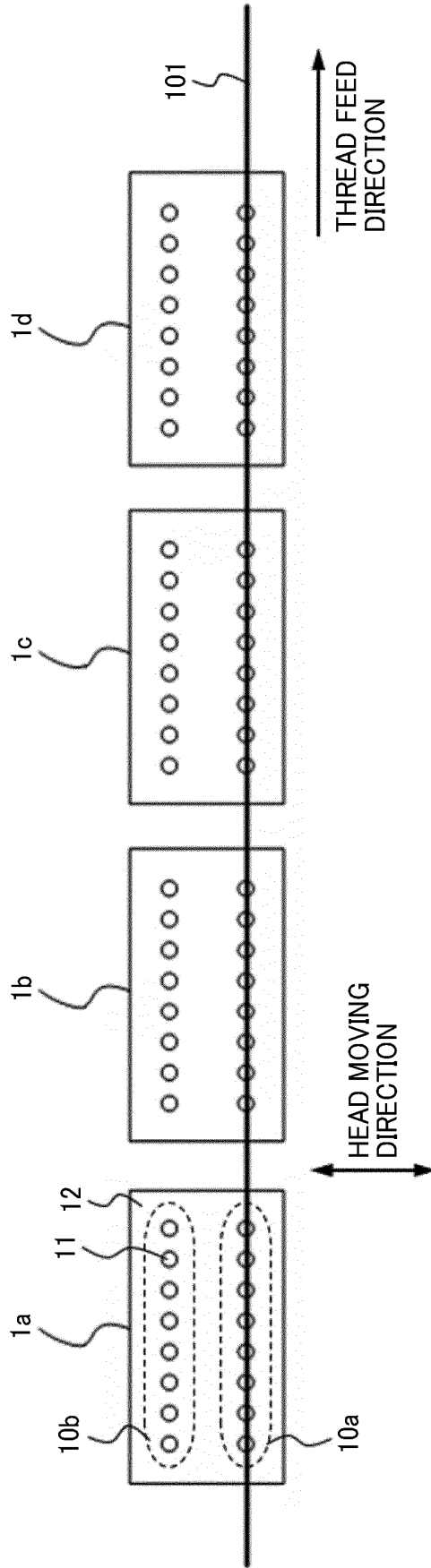

FIG. 4A

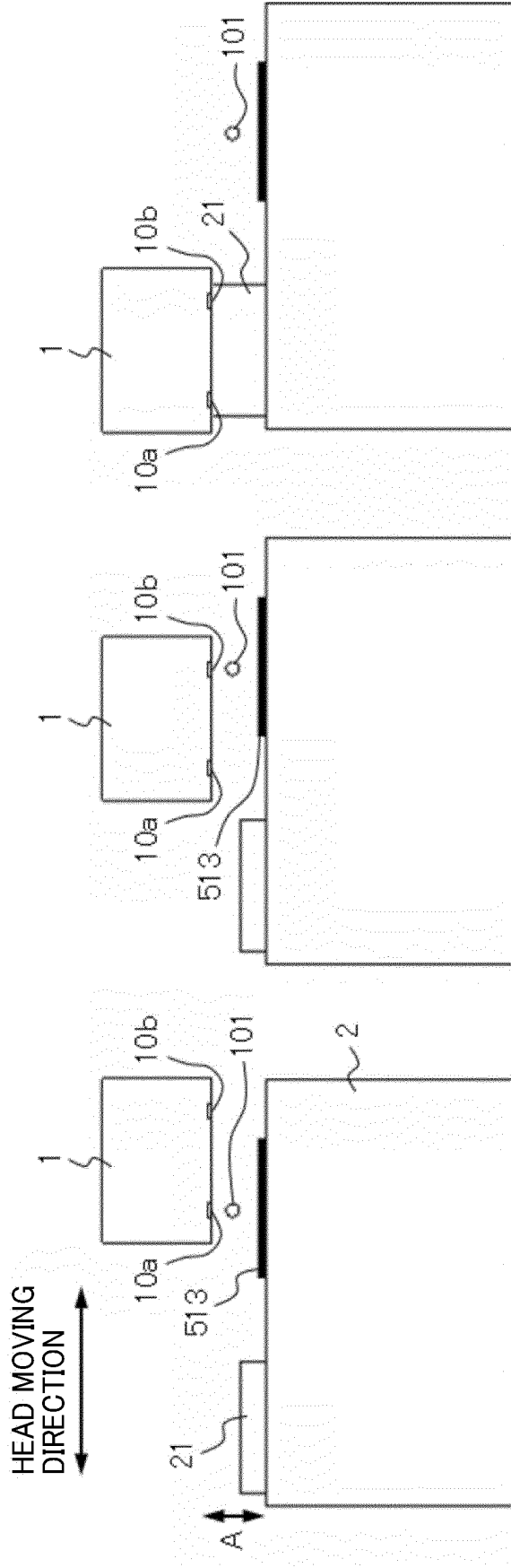

FIG. 4B

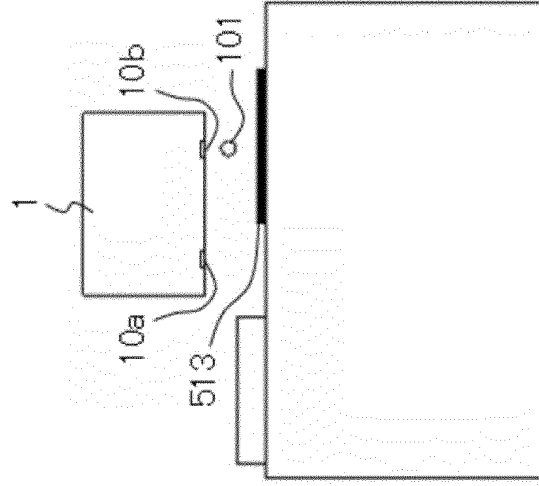
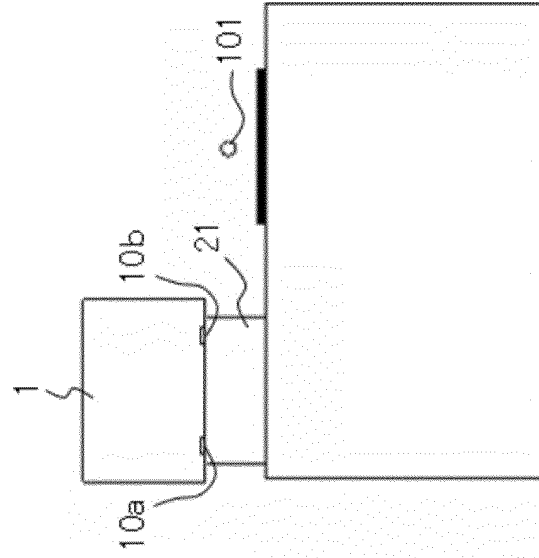

FIG. 4C



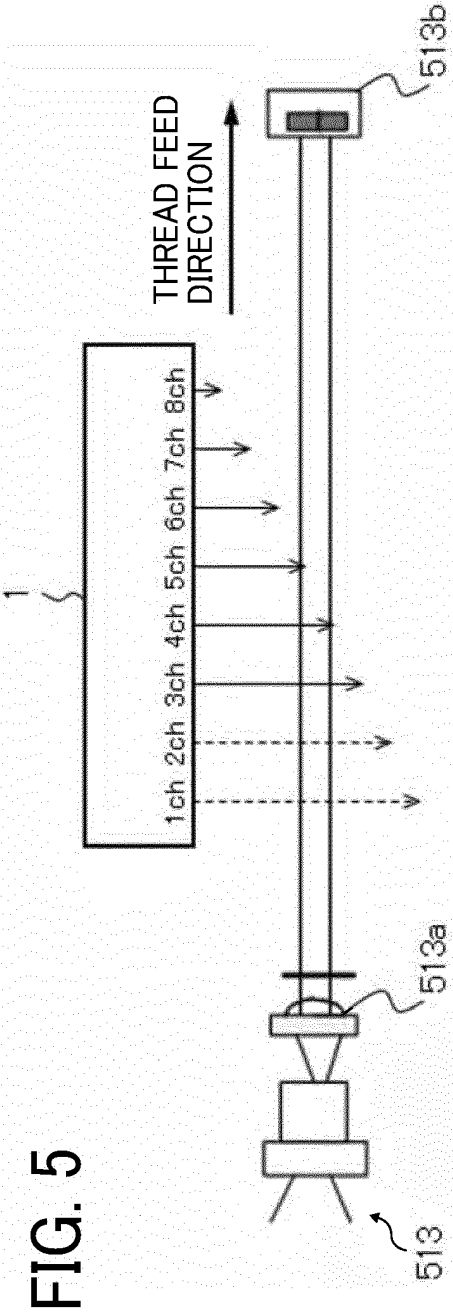

FIG. 5

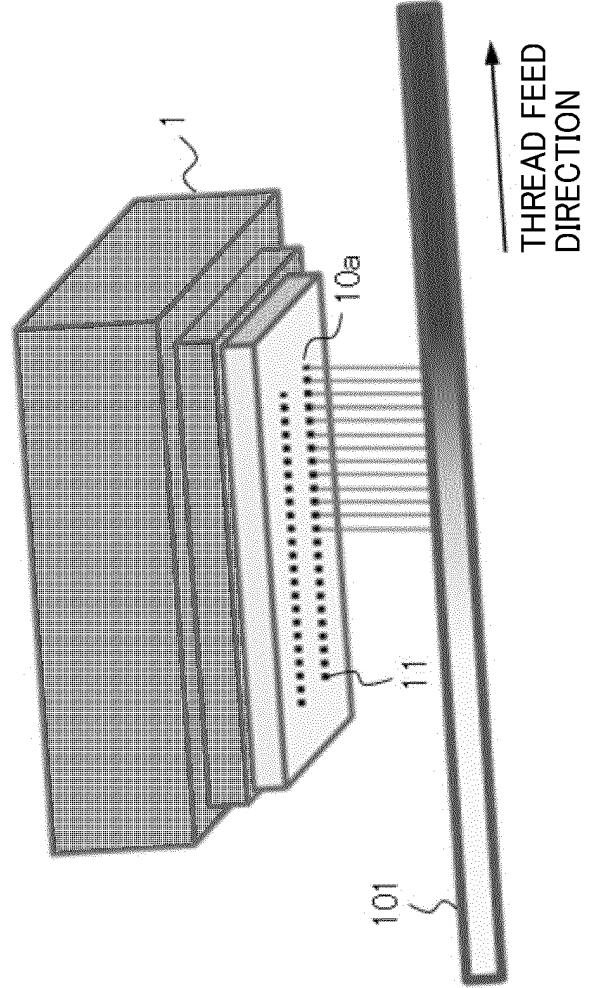

FIG. 6

FIG. 7

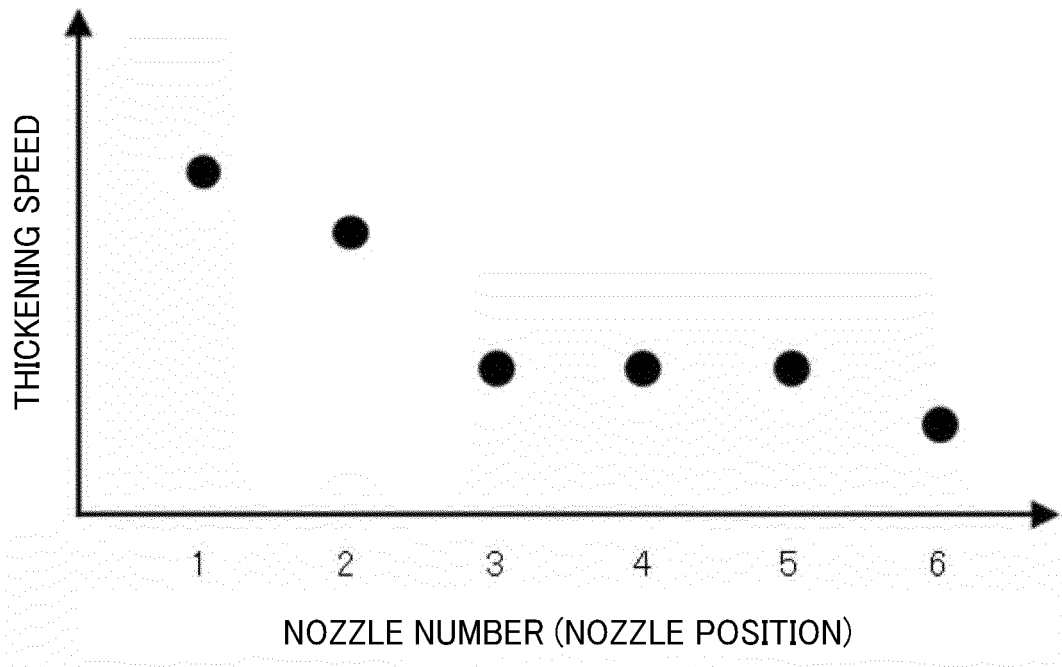

FIG. 8C

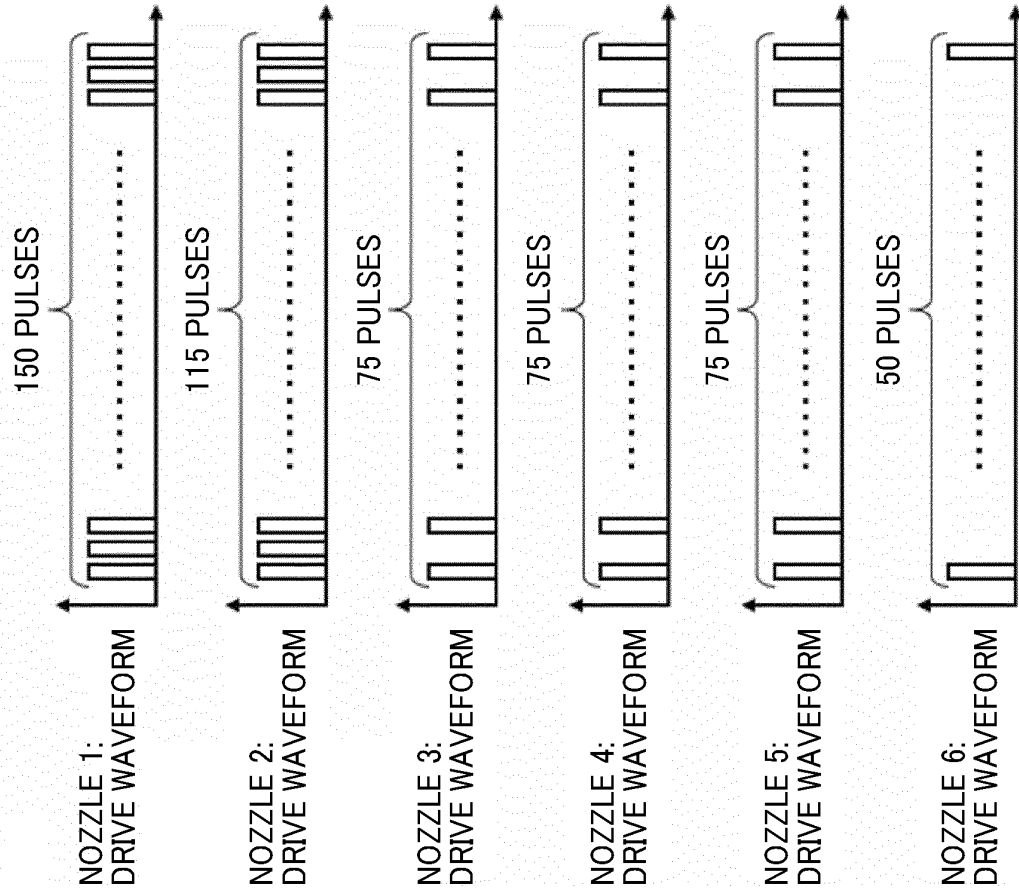

FIG. 8A

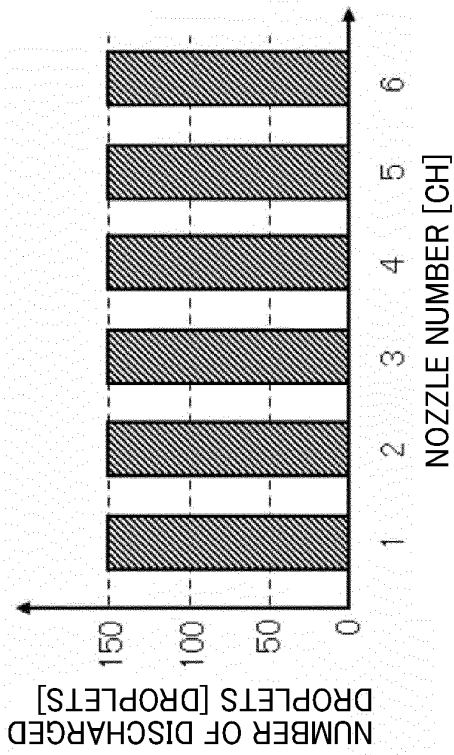

FIG. 8B

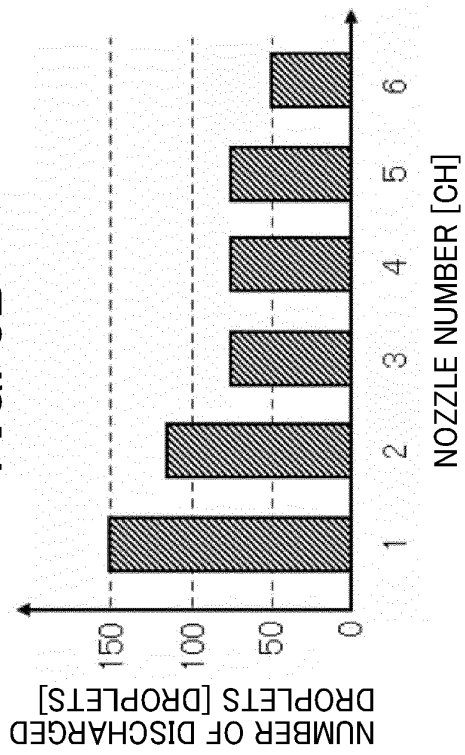

FIG. 9B

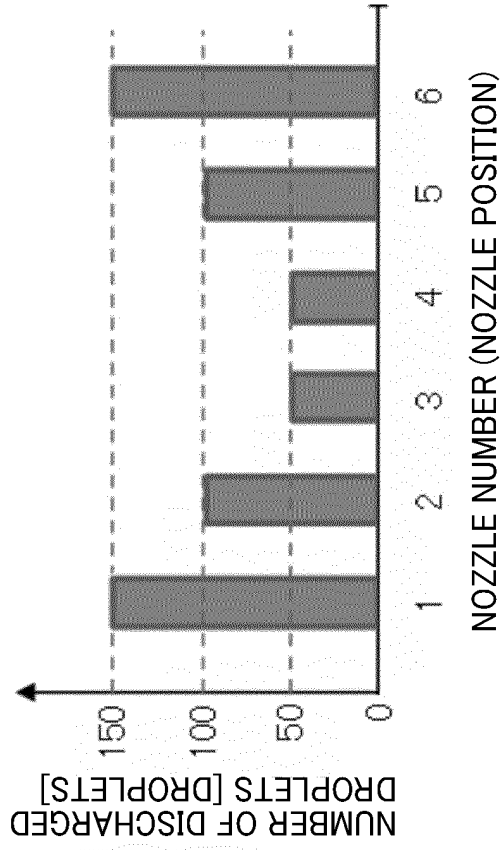

FIG. 9A

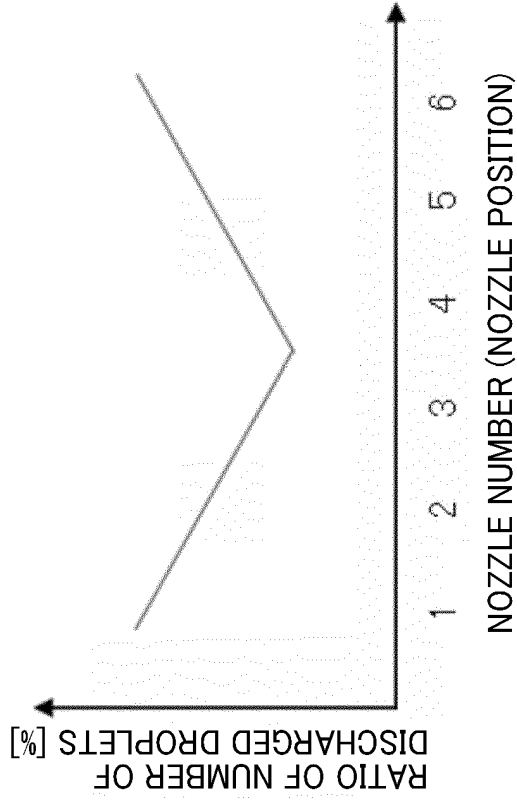

FIG. 10

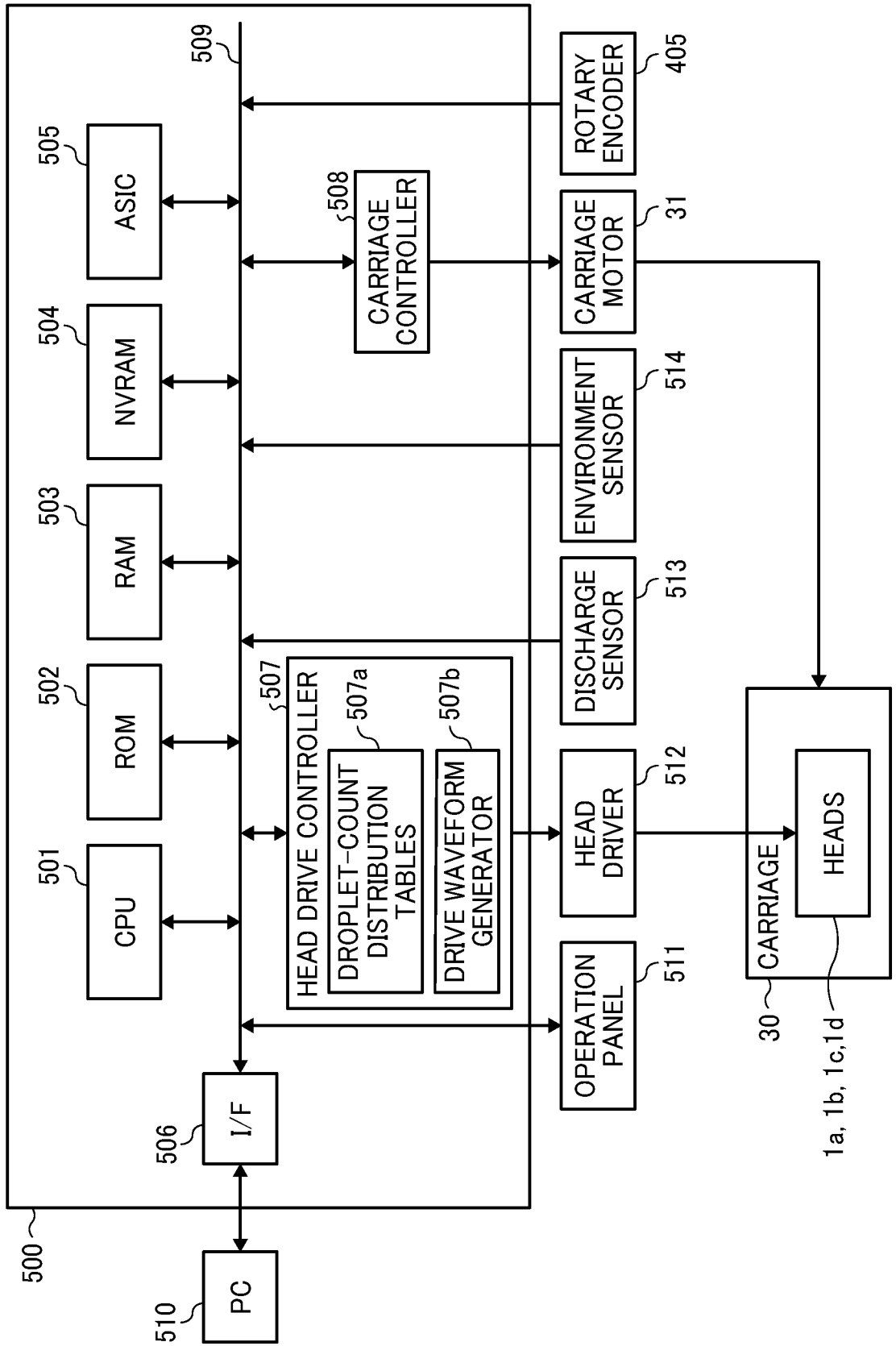

FIG. 11

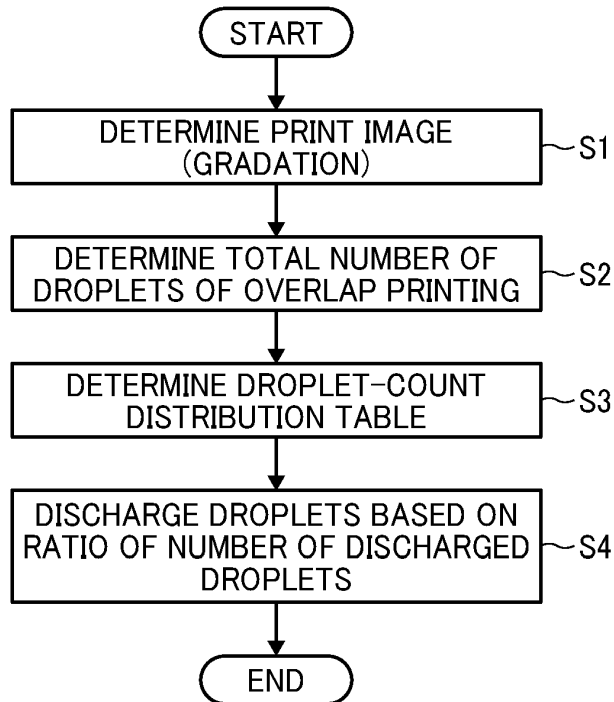
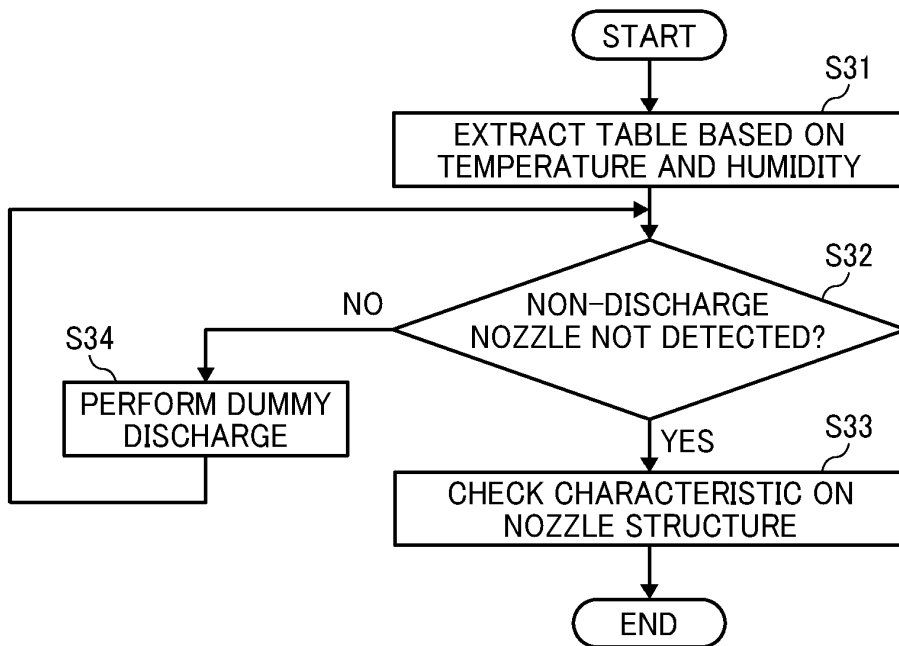

FIG. 12



REFERENCES CITED IN THE DESCRIPTION

This list of references cited by the applicant is for the reader's convenience only. It does not form part of the European patent document. Even though great care has been taken in compiling the references, errors or omissions cannot be excluded and the EPO disclaims all liability in this regard.

Patent documents cited in the description

- JP 2018144337 A [0002]
- US 20130182034 A1 [0003]
- US 20170203570 A1 [0003]