

(19)



(11)

**EP 4 119 353 B1**

(12)

**EUROPEAN PATENT SPECIFICATION**

(45) Date of publication and mention of the grant of the patent:  
**05.03.2025 Bulletin 2025/10**

(51) International Patent Classification (IPC):  
**B41J 3/60<sup>(2006.01)</sup> B41J 13/00<sup>(2006.01)</sup>**  
**B41J 15/04<sup>(2006.01)</sup>**

(21) Application number: **21185151.4**

(52) Cooperative Patent Classification (CPC):  
**B41J 3/60; B41J 13/0045; B41J 13/009;**  
**B41J 15/04**

(22) Date of filing: **12.07.2021**

(54) **ROLL-FED PRINTER, SOFTWARE MEDIUM AND METHOD FOR DOUBLE-SIDED PRINTING ON A WEB**

DRUCKER MIT ROLLENZUFÜHRUNG, SOFTWAREMEDIUM UND VERFAHREN ZUM BEIDSEITIGEN BEDRUCKEN EINER BAHN

IMPRIMANTE ALIMENTÉE PAR ROULEAU, SUPPORT LOGICIEL ET PROCÉDÉ D'IMPRESSION RECTO-VERSO SUR UNE BANDE

(84) Designated Contracting States:  
**AL AT BE BG CH CY CZ DE DK EE ES FI FR GB GR HR HU IE IS IT LI LT LU LV MC MK MT NL NO PL PT RO RS SE SI SK SM TR**

(43) Date of publication of application:  
**18.01.2023 Bulletin 2023/03**

(73) Proprietor: **Canon Production Printing Holding B.V.**  
**5914 HH Venlo (NL)**

(72) Inventors:  
 • **VULPE, Radu**  
**Venlo (NL)**

• **MURESAN, Alexandru, I.**  
**Venlo (NL)**

(74) Representative: **Canon Production Printing IP Department**  
**Canon Production Printing Netherlands B.V.**  
**Van der Grintenstraat 10**  
**5914 HH Venlo (NL)**

(56) References cited:  
**EP-A1- 3 822 764 US-A1- 2011 002 721**  
**US-A1- 2011 211 003**

**EP 4 119 353 B1**

Note: Within nine months of the publication of the mention of the grant of the European patent in the European Patent Bulletin, any person may give notice to the European Patent Office of opposition to that patent, in accordance with the Implementing Regulations. Notice of opposition shall not be deemed to have been filed until the opposition fee has been paid. (Art. 99(1) European Patent Convention).

## Description

### FIELD OF THE INVENTION

[0001] The present invention generally pertains to a method for double-sided printing on a web by means of a roll-fed printer comprising an input holder for the web, an output holder for the web, a print head assembly on a paper path from the input holder to the output holder, a print controller to control the printing of digital images on the web and a user interface, the method comprising the steps of scheduling first images to be printed on a first side of the web and second images to be printed on a second side of the web, printing the first images on the first side of the web fed from the input holder towards the output holder, receiving a first signal that the one-sided printed web is inserted at the input holder in order allow a start of printing on the second side of the web, starting printing the second images on the second side of the web fed from the input holder and receiving an error signal or a user interface signal causing a print stop leaving a remaining part of the second side of the web unprinted.

[0002] The present invention also pertains to a software medium comprising executable code configured to, when executed, perform a method for controlling the roll-fed printer.

[0003] The present invention also pertains to a roll-fed printer configured to execute the method according to the present invention.

[0004] The term "printing" is used herein as a general term for any marking of a web with any marking material. As a synonym, the term "image forming" may be used. Webs may comprise paper, flexible plastic, metal foils, textiles and so on. Marking materials may comprise ink, metal, varnish, toner and so on. "Marking" may be any process by which the marking material is applied to the web.

[0005] The term "double-sided printing" is used herein as a general term for any marking of a web with any marking material wherein the web has two sides, a front side and a back side and the printing subsequently occurs on the front side and the back side. When a front side of the web has been printed, the one-sided printed web is unloaded and put again on the input holder in order to print on the back side of the web. Mechanisms are known in the art to achieve that the one-sided printed web is inserted in the paper path in such a way that the back side is positioned to receive marking material from nozzles of the print head assembly. Such a mechanism is for example described in patent

### BACKGROUND ART

[0006] Roll-fed printers are a well-known type of printers. In roll-fed printers, a web such as paper is wound up on an input roll and then fed into, and guided along, a path through the printer, unwinding the input roll by and by along the process. In this way, the web is roll-fed (i.e.

taken from a roll and fed) to a marking unit of the printer which applies a marking material (prints) onto the web, [0007] Roll-fed printers are a common type of roll-fed printers and are characterized in that the web is, after images have been printed on it, wound up on an output holder of an output roll by and by along the process.

[0008] Roll-fed printers are very efficient devices for forming a large number of images requiring a large amount of the web, as the wound-up input rolls are comparatively easy to handle by both the printers and their operating personnel. Accordingly, little or no supervision by personnel is needed for roll-fed printers, especially for roll-fed printers, as the marked web is automatically stored on the output roll.

[0009] When any problems arise during the printing of the image of the web, this may result in a considerable loss of resources such as time (because the printing process might be, or might have to be, stopped until a person can solve the problems) or web and marking material (because a started larger image might be irreparably botched and has to be started anew).

[0010] Patent application EP 3822764 A1 describes a method for continuing, after the occurrence of an error, printing on a web in a roll-to-roll printer in a double-sided roll-to-roll printing process. The web is cut into two portions at the position of compromised images.

[0011] In particular, when printing has already been completed on the front side and the problem occurs on the back side of the web, the loss of resources may be even more, since there may be a considerable number of images on the front side which do not yet have an image printed at the back side of the web.

[0012] Some failures might need operator intervention before the roll-fed printer is able to print again correctly, e.g. nozzle cleaning. In the eventuality of a paper jam that does not tear the paper and does mess with the media alignment printing cannot be continued respecting the front-back alignment. In some cases where defective nozzles are involved or some other hardware issues continuing to print does not guarantee the quality of the print (even if the error is initially on a small part of the printed images).

[0013] It is desirable to have a method for double-sided printing on a web which mitigates the loss of web or loss of print quality when an error occurs when printing images on the backside of the web and images on the front side of the web have been completely printed. It is also desirable to have a roll-fed printer capable of executing such a method.

### SUMMARY OF THE INVENTION

[0014] According to the present invention, the method further comprises the steps of determining a remaining part of the second images not yet printed on the second side of the web due to the print stop, feeding the web forward towards the output holder until the web is completely wound up at the output holder, receiving a second

signal that the web is inserted at the input holder in order to allow a start of printing the remaining part of the second images in a reverse order on the remaining part of the second side of the web, and printing the remaining part of the second images in the reverse order on the remaining part of the second side of the web.

**[0015]** By doing so, as much web as possible is recovered after the print error occurs in the double-sided print job.

**[0016]** According to an embodiment the method comprises the steps of determining at least one image of the first images adversely affected due to the print stop, and rescheduling by the print controller of the at least one image of the first images which are adversely affected due to the print stop and at least one image of the second images being scheduled to be printed on the back side of the at least one adversely affected image of the first images, for printing on another web.

**[0017]** According to an embodiment the method comprises the steps of registering the start position of a first image on the first side of the web and using the registered start position at the beginning of the printing of the remaining part of the second images in the reverse order on the remaining part of the second side of the web. In order to have a correct front-back registration a leading and trailing edge have a same length. The leading and trailing edge have to be sufficiently long to be able to have the web be picked up from the outgiving input holder and by the receiving output holder. The leading and trailing edge maybe marked with a printed line if a manual cut can be done. If the print issue is an error which can be detected automatically during printing, the markers are strictly not necessary, as the print controller knows what part of the images was being printed when the error occurred, i.e. the web location of the error is also known. Space may be allocated on a side of the printed images for a length marker so that the operator knows how much of the printed images has been completed. The length marker may be added after each individual image or a predefined distances and may be numbers or combinations numbers and letters.

**[0018]** The present invention also relates to a roll-fed printer comprising an input holder for the web, an output holder for the web, a print head assembly on a paper path from the input holder to the output holder, a print controller to control the printing of digital images on the web and a user interface, wherein the print controller is configured to perform the steps of the method according to claim 4.

**[0019]** The present invention also relates to a software medium comprising computer executable program code which, when executed by a computer, causes the computer to perform the steps of the method according to claim 5.

**[0020]** The software medium may, specifically, be formed as a CD or a CD-ROM, a DVD or a DVD-ROM, a BluRay disc or a BluRay-ROM disc, a magnetic hard drive, a solid state disk (SSD) hard drive, a USB memory device and so on.

**[0021]** Additional advantages, and the solution of additional problems, will be apparent from the subject-matter of the dependent claims as well as from the description and the drawings.

## BRIEF DESCRIPTION OF THE DRAWINGS

**[0022]** The present invention will become more fully understood from the detailed description given hereinbelow and the accompanying schematic drawings which are given by way of illustration only, and thus are not limitative of the present invention, and wherein:

FIG. 1 schematically shows a roll-fed printer according to the invention;

FIG. 2A - 2C schematically shows a scenario wherein the method according to the invention is applicable; and

FIG. 3A - 3B show a schematic flow diagram illustrating a method according to the invention.

## DETAILED DESCRIPTION OF THE DRAWINGS

**[0023]** The present invention will now be described with reference to the accompanying drawings, wherein the same reference numerals have been used to identify the same or similar elements throughout the several views, and in some instances throughout the several embodiments.

**[0024]** FIG. 1 shows a roll-fed printing system 51 connected to a network N. The roll-fed printing system 51 is available for a user working with one of workstations 8A - 8C and intending to send a digital image from one of the workstations 8A - 8C to a print controller 13 inside of the roll-fed printing system 51. The roll-fed printing system 51 is connected to the network N via wired or wireless connecting means 6 and suited for receiving digital images from the workstations 8A - 8C. The network N may be wireless. The roll-fed printing system 51 comprises one input holder 1a for a web 1 and one output holder 3d for the printed web 3. The roll-fed printing system 51 comprises a user interface 16 suitable for displaying the digital image queue according to the invention by means of digital images to be printed.

**[0025]** The workstations 8A - 8C may be replaced by mobile devices like tablets, notebooks, laptops, etc.

**[0026]** The print controller 13 comprises a scheduler 19 for scheduling the digital images submitted to the roll-fed printing system 51 in the digital image queue according to the invention. The digital image queue is stored in digital storage 7 in the print controller 13. The print controller 13 comprises a data controller 15 for controlling the printing process and data transfer between the print controller 13 and the user interface 16.

**[0027]** In another embodiment the control unit of the roll-fed printing system 51 is integrated in one of the workstations 8A - 8C wired or wireless connected to roll-fed printing system 51. In another embodiment a user

interface is provided as a network web site or intranet site that is accessible with a browser on a client computer.

**[0028]** The print controller 13 is suited to store a set of digital images, to check whether or not the digital images can be printed and to submit a digital image to a print head assembly 18 of the roll-fed printing system 51 in order to be printed on the web 9. Image data of a digital image are stored in digital storage 7 contained in the print controller 13 at least for the time period that the digital image is printed by the print head assembly 18. Image data may be composed and also stored in memory of at least one of the workstations 8A - 8C.

**[0029]** The roll-fed printing system 51 processes at least part of the web 9 of the input holder 1a. The wound web 1b has a length which is defined as a largest dimension of the web when unrolled. Web material may be paper, textile, transparent sheet material, plastic or any other kind of material or substrate suitable for winding up at the input holder 1a. The wound web 1b is placed in the input holder 1a.

**[0030]** Individual digital images will be printed on the unwound web 9 given out of the input holder 1a. The individual digital images are printed by the print head assembly 18 of the roll-fed printing system 51 according to the digital image queue. The unwound web 9 is guided along the print head assembly 18. The printed web 9 is guided to and wound up on the output holder 3d.

**[0031]** FIG. 2A - 2C show a scenario in which the method according to the invention is applied.

**[0032]** In FIG. 2A, a schematic view of a web 9 with a number of 16 images 1A - 16A planned to be printed on the first side of the web 9. The number of 16 images is only chosen as an example; it should be understood that less, or more, individual images may be printed on the web 9. The leading edge has a predetermined length L1 and the trailing edge has a predetermined length L2. The leading edge may have a same length as the trailing edge.

**[0033]** The roll-fed printer 51 prints the plurality of images 1A - 16A on the web 9. The printing of the first side of the web 9 completes without errors.

**[0034]** When the first side is finished, the printed web 9 is inserted as a feed roll in the input holder 1a again to print the second side of the web 9. The second side is intended to be printed with images 1B - 16B. What was originally the trailing edge is the free edge on the web 9 and becomes the leading edge. Therefore, the images 1B - 16B on the second side are printed in reverse order relative to the first side. It is noted that the images 1B - 16B have to be rotated upside-down (180 degrees) before printing can start. Such a rotation may be performed by an image editing program installed in the print controller. An error occurs after printing a couple of images as shown in FIG. 2B. For example image 14B is not completed correctly as indicated by the lighting icon in image 14B.

**[0035]** Printing stops. The web 9 is now fed forward until it is completely on the output holder 3d, which acts as a pickup holder. The web 9 is then inserted again as the

feed roll in the input holder 1a. Now a second attempt can be made to print the second side, but now starting from the other side of the roll. What was originally the leading edge when printing the first side, is now again the leading edge as the web 9 has been reversed twice. The remaining images, in this example the images 1B-13B, are now printed with the order reversed from the first attempt as shown in FIG. 2C. In order to get the front-back registration correct the start of the first image on the first side should be known, for example as the distance L1 of the start of this image from the leading edge. The distance L1 may be entered via the user interface 16 or may be predetermined as an initializing print parameter and stored in memory of the print controller 13.

**[0036]** Now, printing of the web 9 has completed. Only the image 14B directly affected by the printing error was not printed correctly. The other images (images 1B-13B and 15B-16B) have all printed correctly and correctly registered with the images on the other side (images 1A-13A and 15A-16A). Only the images 14A-B need to be rescheduled for printing.

**[0037]** FIG. 3A-3B show a schematic flow diagram illustrating a method according to the invention. The method is suitable for controlling the roll-fed printer according to the invention for double-sided printing images on the web 9.

**[0038]** The method start in starting point A in FIG. 3A which leads to a first step S1.

**[0039]** In the first step S1 first images are scheduled to be printed on a first side of the web and second images to be printed on a second side of the web. The scheduling takes place in the print controller 13 or even outside the print controller 13 on one of the workstations 8A -8C.

**[0040]** In a second step S2 the first images are printed on the first side of the web fed from the input holder towards the output holder.

**[0041]** In a third step S3 a first signal is received that the one-sided printed web is inserted at the input holder in order allow a start of printing on the second side of the web. The first signal may come from a sensor in the input holder or from user input at the user interface of the roll-fed printer.

**[0042]** In a fourth step S4 the second images are started to be printed on the second side of the web fed from the input holder. Before printing, the second images are digitally and automatically rotated upside-down (180 degrees) by an ordinary image editing program installed in the print controller.

**[0043]** In a fifth step S5 an error signal or a user interface signal is received causing a print stop leaving a remaining part of the second side of the web unprinted. The error signal may come from a sensor in the paper path of the roll-fed printer. The user interface signal may come from user input at the user interface of the roll-fed printer.

**[0044]** In a sixth step S6 a remaining part of the second images is determined which is not yet printed on the second side of the web due to the print stop.

[0045] The method proceeds to an intermediate point B which leads to a seventh step S7 as shown in FIG. 3B.

[0046] In the seventh step S7 the web is fed forward towards the output holder until the web is completely wound up at the output holder. During the feed forward no images are printed on the web.

[0047] In an eight step S8 a second signal is received that the web is inserted at the input holder in order to allow a start of printing the remaining part of the second images in a reverse order on the remaining part of the second side of the web.

[0048] In a ninth step S9 the remaining part of the second images is printed in the reverse order on the remaining part of the second side of the web.

[0049] The method ends in an end point C.

[0050] While detailed embodiments of the present invention are disclosed herein, it is to be understood that the disclosed embodiments are merely exemplary of the invention, which can be embodied in various forms, without departing from the scope of the appended claims. Therefore, specific structural and functional details disclosed herein are not to be interpreted as limiting, but merely as a basis for the claims and as a representative basis for teaching one skilled in the art to variously employ the present invention in virtually any appropriately detailed structure. In particular, features presented and described in separate dependent claims may be applied in combination and any advantageous combination of such claims are herewith disclosed.

[0051] Further, the terms and phrases used herein are not intended to be limiting; but rather, to provide an understandable description of the invention. The terms "a" or "an", as used herein, are defined as one or more than one. The term plurality, as used herein, is defined as two or more than two. The term another, as used herein, is defined as at least a second or more. The terms including and/or having, as used herein, are defined as comprising (i.e., open language).

## Claims

1. A method for double-sided printing on a web by means of a roll-fed printer (51) comprising an input holder (1a) for the web (1), an output holder (3d) for the web (3), a print head assembly (18) on a paper path from the input holder (1a) to the output holder (3d), a print controller (13) to control the printing of digital images (1A - 16A, 1B - 16B) on the web (1) and a user interface (16), the method comprising the steps of

- a) scheduling first images (1A - 16A) to be printed on a first side of the web (9) and second images (1B - 16B) to be printed on a second side of the web (9),
- b) printing the first images (1A - 16A) on the first side of the web (9) fed from the input holder (1a)

towards the output holder (3b),

c) receiving a first signal that the one-sided printed web is inserted at the input holder (1a) in order allow a start of printing on the second side of the web (9),

d) starting printing the second images (1B - 16B) on the second side of the web (9) fed from the input holder (1a),

e) receiving an error signal or a user interface signal causing a print stop leaving a remaining part (1B - 13B) of the second side of the web (9) unprinted,

f) determining the remaining part (1B - 13B) of the second images not yet printed on the second side of the web (9) due to the print stop,

g) receiving a second signal that the web (9) is inserted at the input holder (1a) in order to allow a start of printing the remaining part (1B - 13B) of the second images in a reverse order on the remaining part of the second side of the web (9), and

h) printing the remaining part (1B - 13B) of the second images in the reverse order on the remaining part of the second side of the web (9),

**characterized in that** the method comprises between steps step f) and g) the step of feeding the web (9) forward towards the output holder (3b) until the web (9) is completely wound up at the output holder (3b).

2. The method according to claim 1, wherein the method comprising the steps of determining at least one image of the first images adversely affected due to the print stop, and rescheduling by the print controller of the at least one image of the first images which are adversely affected due to the print stop and at least one image of the second images being scheduled to be printed on the back side of the at least one adversely affected image of the first images, for printing on another web.
3. The method according to any of the preceding claims, wherein the method comprises the steps of registering the start position of a first image on the first side of the web and using the registered start position at the beginning of the printing of the remaining part of the second images in the reverse order on the remaining part of the second side of the web.
4. A roll-fed printer (51) comprising an input holder (1a) for a web (9), an output holder (3b) for the web (9), a print head assembly (18) on a paper path from the input holder (1a) to the output holder (3b), a print controller (13) to control the printing of digital images (1A -16A, 1B - 16B) on the web (9) and a user interface (16), wherein the print controller (13) is configured to perform the steps of the method ac-

ording to any of the claims 1 - 3.

5. A software medium (7) comprising computer executable program code which, when executed by a computer (13), causes the computer to perform the steps of the method according to any of the claims 1 - 3, for double-sided printing on a web (9) by means of a roll-fed printer (51) according to claim 4.

### Patentansprüche

1. Verfahren zum beidseitigen Bedrucken einer Bahn mittels eines Rollendruckers (51), der einen Eingabehalter (1a) für die Bahn (1), einen Ausgabehalter (3d) für die Bahn (3), eine Druckkopfanordnung (18) auf einem Papierweg von dem Eingabehalter (1a) zum Ausgabehalter (3d), eine Drucksteuerung (13) zum Steuern des Druckens digitaler Bilder (1A - 16A, 1B - 16B) auf der Bahn (1) und eine Benutzerschnittstelle (16) umfasst, wobei das Verfahren die folgenden Schritte umfasst

a) Planung von ersten Bildern (1A - 16A), die auf eine erste Seite der Bahn (9) gedruckt werden sollen, und zweiten Bildern (1B - 16B), die auf eine zweite Seite der Bahn (9) gedruckt werden sollen,

b) Drucken der ersten Bilder (1A - 16A) auf die erste Seite der vom Eingabehalter (1a) zum Ausgabehalter (3b) zugeführten Bahn (9),

c) Empfang eines ersten Signals, dass die einseitig bedruckte Bahn in den Eingabehalter (1a) eingelegt wird, um den Druck auf der zweiten Seite der Bahn (9) zu beginnen,

d) Beginn des Drucks der zweiten Bilder (1B - 16B) auf der zweiten Seite der vom Eingabehalter (1a) zugeführten Bahn (9),

e) Empfang eines Fehlersignals oder eines Signals der Benutzerschnittstelle, das einen Druckstopp auslöst und einen verbleibenden Teil (1B - 13B) der zweiten Seite der Bahn (9) unbedruckt lässt,

f) Bestimmung des verbleibenden Teils (1B - 13B) der zweiten Bilder, die aufgrund des Druckstopps noch nicht auf der zweiten Seite der Bahn (9) gedruckt wurden,

g) Empfangen eines zweiten Signals, dass die Bahn (9) in den Eingabehalter (1a) eingelegt ist, um den Beginn des Druckens des verbleibenden Teils (1B - 13B) der zweiten Bilder in umgekehrter Reihenfolge auf den verbleibenden Teil der zweiten Seite der Bahn (9) zu ermöglichen, und

h) Drucken des verbleibenden Teils (1B - 13B) der zweiten Bilder in umgekehrter Reihenfolge auf den verbleibenden Teil der zweiten Seite der

Bahn (9),

**dadurch gekennzeichnet, dass** das Verfahren zwischen den Schritten f) und g) den Schritt des Vorschubs der Bahn (9) in Richtung des Ausgabehalters (3b) umfasst, bis die Bahn (9) am Ausgabehalter (3b) vollständig aufgewickelt ist.

2. Verfahren nach Anspruch 1, wobei das Verfahren die Schritte des Bestimmens mindestens eines Bildes der ersten Bilder, das aufgrund des Druckstopps beeinträchtigt ist, und des Umplanens des mindestens einen Bildes der ersten Bilder, das aufgrund des Druckstopps beeinträchtigt ist, und mindestens eines Bildes der zweiten Bilder, das zum Drucken auf der Rückseite des mindestens einen beeinträchtigten Bildes der ersten Bilder vorgesehen ist, durch die Drucksteuerung zum Drucken auf eine andere Bahn umfasst.

3. Das Verfahren nach einem der vorhergehenden Patentansprüche, wobei das Verfahren die Schritte des Registrierens der Startposition eines ersten Bildes auf der ersten Seite der Bahn und des Verwendens der registrierten Startposition zu Beginn des Druckens des verbleibenden Teils der zweiten Bilder in umgekehrter Reihenfolge auf dem verbleibenden Teil der zweiten Seite der Bahn umfasst.

4. Rollendrucker (51) mit einem Eingabehalter (1a) für eine Bahn (9), einem Ausgabehalter (3b) für die Bahn (9), einer Druckkopfanordnung (18) auf einem Papierweg von dem Eingabehalter (1a) zum Ausgabehalter (3b), einer Drucksteuerung (13) zum Steuern des Druckens digitaler Bilder (1A - 16A, 1B - 16B) auf der Bahn (9) und einer Benutzerschnittstelle (16), wobei die Drucksteuerung (13) so konfiguriert ist, dass sie die Schritte des Verfahrens nach einem der Patentansprüche 1 - 3 ausführt.

5. Softwaremedium (7), das einen computerausführbaren Programmcode enthält, der, wenn er von einem Computer (13) ausgeführt wird, den Computer veranlasst, die Schritte des Verfahrens nach einem der Patentansprüche 1 bis 3 zum beidseitigen Bedrucken einer Bahn (9) mittels eines Rollendruckers (51) nach Anspruch 4 durchzuführen.

### Revendications

1. Procédé d'impression recto-verso sur une bande au moyen d'une imprimante à rouleaux (51) comprenant un support d'entrée (1a) pour la bande (1), un support de sortie (3d) pour la bande (3), un ensemble de tête d'impression (18) sur un chemin de papier allant du support d'entrée (1a) au support de sortie (3d), un contrôleur d'impression (13) pour comman-

der l'impression d'images numériques (1A - 16A, 1B - 16B) sur la bande (1) et une interface utilisateur (16), le procédé comprenant les étapes suivantes

- a) programmer les premières images (1A - 16A) à imprimer sur une première face de la bande (9) et les secondes images (1B - 16B) à imprimer sur une seconde face de la bande (9),
- b) imprimer les premières images (1A - 16A) sur le premier côté de la bande (9) acheminée du support d'entrée (1a) vers le support de sortie (3b),
- c) recevoir un premier signal indiquant que la bande imprimée sur une face est insérée dans le support d'entrée (1a) afin de permettre le démarrage de l'impression sur la seconde face de la bande (9),
- d) commencer l'impression des secondes images (1B - 16B) sur le second côté de la bande (9) alimentée par le support d'entrée (1a),
- e) réception d'un signal d'erreur ou d'un signal d'interface utilisateur provoquant un arrêt de l'impression et laissant une partie restante (1B - 13B) de la deuxième face de la bande (9) non imprimée,
- f) déterminer la partie restante (1B - 13B) des secondes images qui n'ont pas encore été imprimées sur la seconde face de la bande (9) en raison de l'arrêt de l'impression,
- g) recevoir un second signal indiquant que la bande (9) est insérée dans le support d'entrée (1a) afin de permettre le début de l'impression de la partie restante (1B - 13B) des secondes images dans un ordre inverse sur la partie restante de la seconde face de la bande (9), et
- h) impression de la partie restante (1B - 13B) des secondes images dans l'ordre inverse sur la partie restante de la seconde face de la bande (9),

**caractérisé en ce que** le procédé comprend entre les étapes f) et g) l'étape consistant à faire avancer la bande (9) vers le support de sortie (3b) jusqu'à ce que la bande (9) soit complètement enroulée au niveau du support de sortie (3b).

2. Procédé selon la revendication 1, dans lequel le procédé comprend les étapes de détermination d'au moins une image des premières images affectée négativement en raison de l'arrêt d'impression, et de reprogrammation par le contrôleur d'impression de l'au moins une image des premières images qui sont affectées négativement en raison de l'arrêt d'impression et d'au moins une image des secondes images étant programmée pour être imprimée sur le verso de l'au moins une image affectée négativement des premières images, pour l'impression d'une autre bande.

3. Procédé selon l'une quelconque des revendications précédentes, dans lequel le procédé comprend les étapes consistant à enregistrer la position de départ d'une première image sur la première face de la bande et à utiliser la position de départ enregistrée au début de l'impression de la partie restante des deuxièmes images dans l'ordre inverse sur la partie restante de la deuxième face de la bande.

4. Imprimante à bobine (51) comprenant un support d'entrée (1a) pour une bande (9), un support de sortie (3b) pour la bande (9), un ensemble de tête d'impression (18) sur un chemin de papier allant du support d'entrée (1a) au support de sortie (3b), un contrôleur d'impression (13) pour commander l'impression d'images numériques (1A - 16A, 1B - 16B) sur la bande (9) et une interface utilisateur (16), dans laquelle le contrôleur d'impression (13) est configuré pour exécuter les étapes du procédé selon l'une quelconque des revendications 1 - 3.

5. Support logiciel (7) comprenant un code de programme exécutable par un ordinateur qui, lorsqu'il est exécuté par un ordinateur (13), amène l'ordinateur à effectuer les étapes du procédé selon l'une quelconque des revendications 1 - 3, pour l'impression recto-verso sur une bande (9) au moyen d'une imprimante à bobines (51) selon la revendication 4.

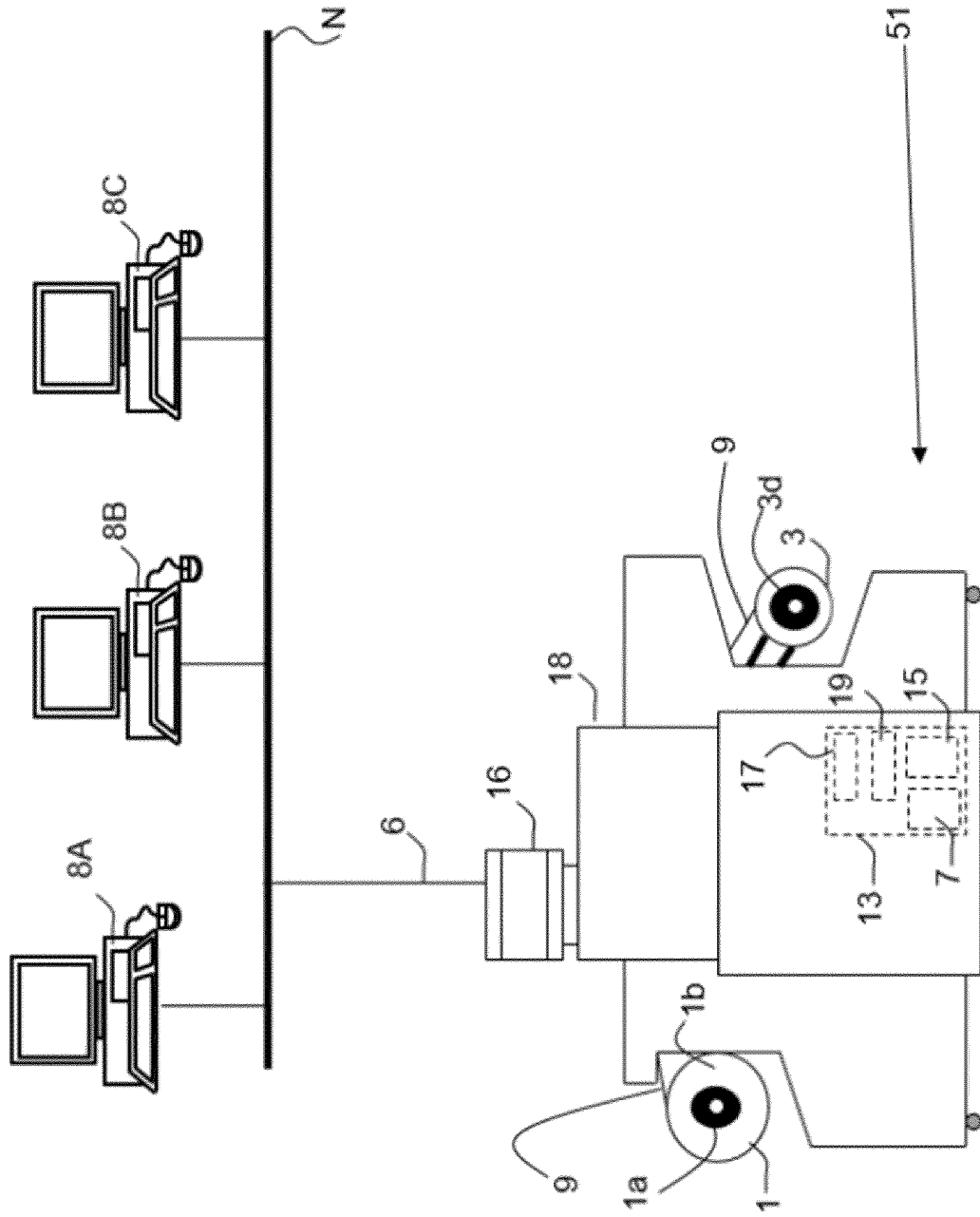

FIG. 1

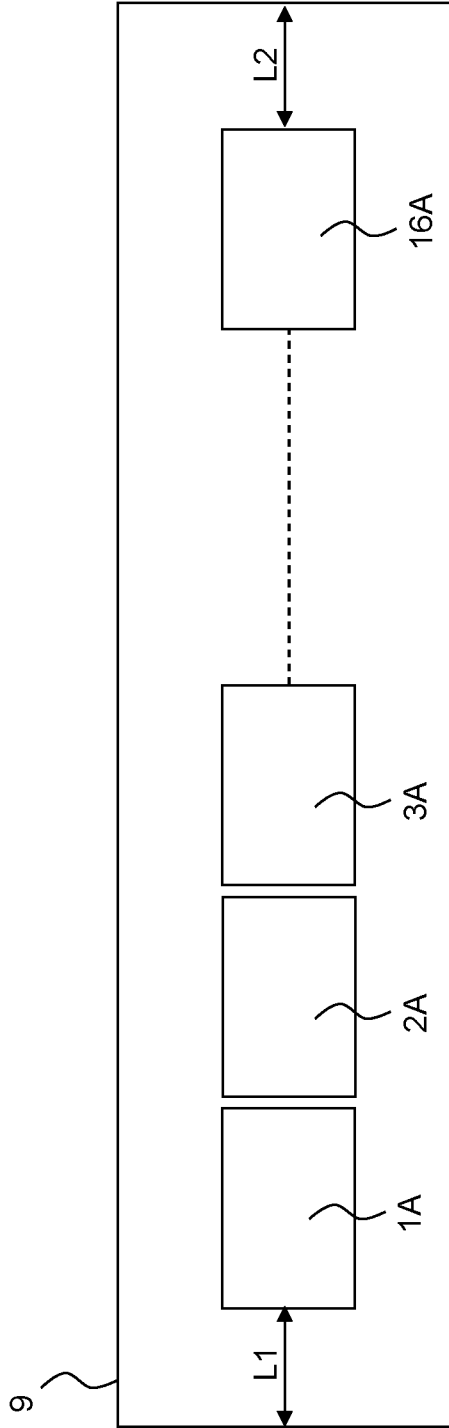

FIG. 2A

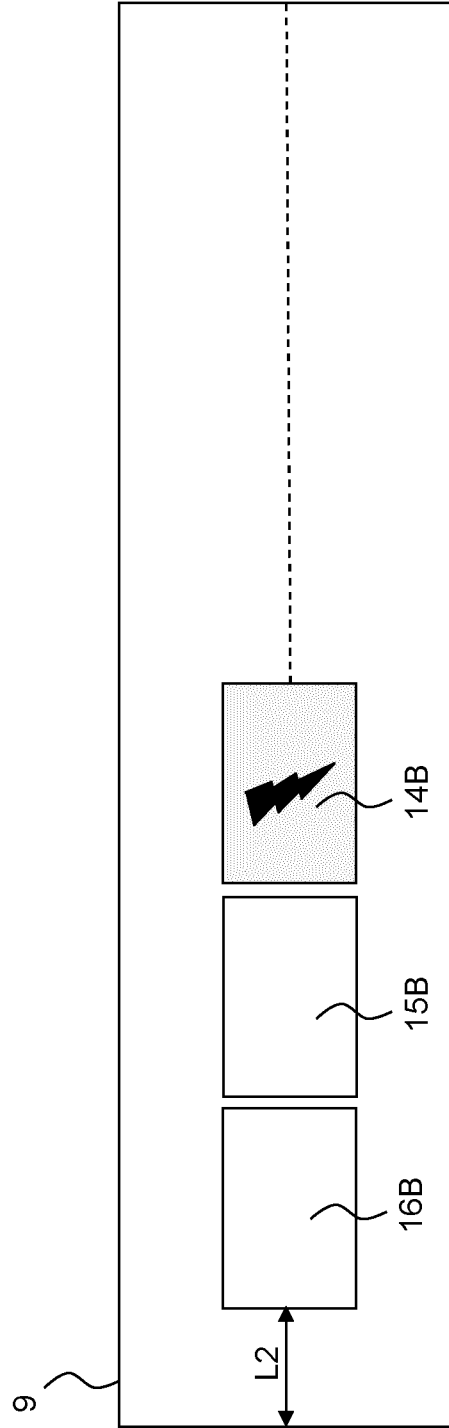

FIG. 2B

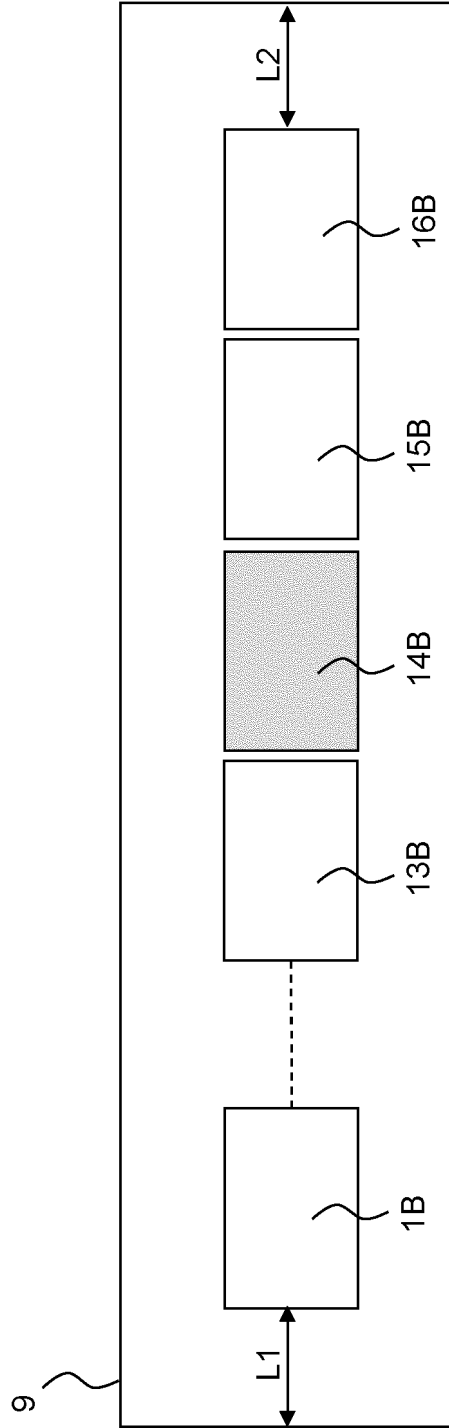

FIG. 2C

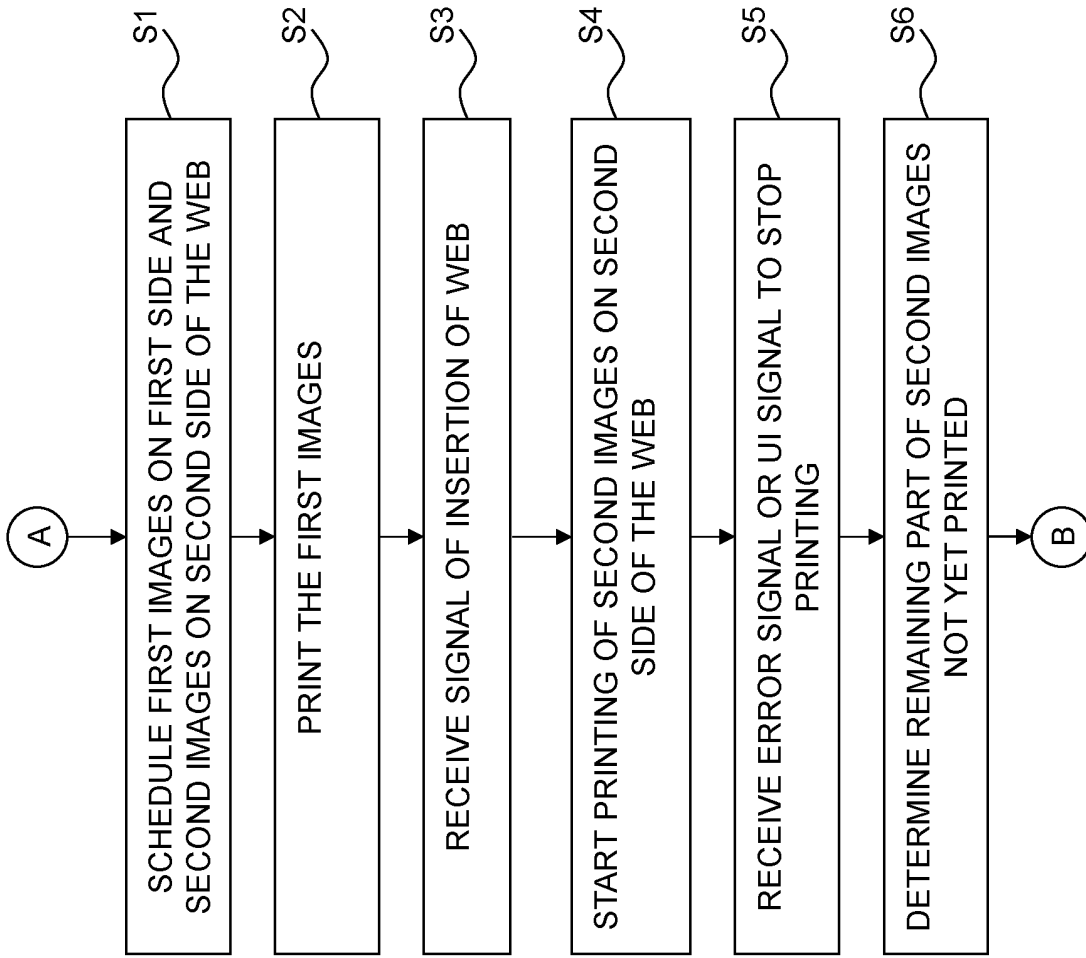

FIG. 3A

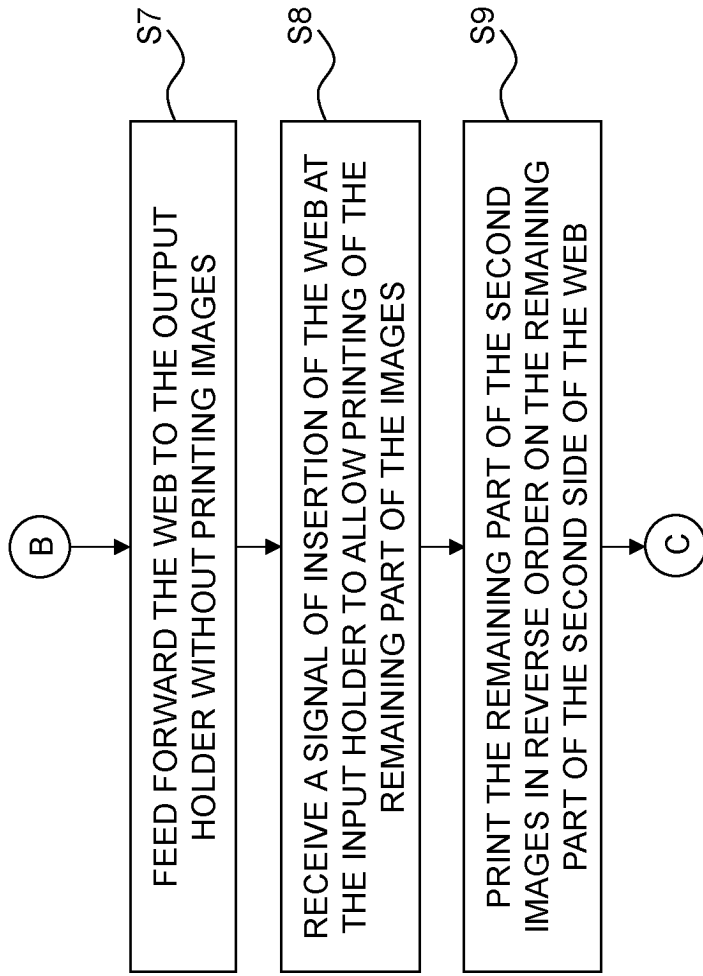

FIG. 3B

**REFERENCES CITED IN THE DESCRIPTION**

*This list of references cited by the applicant is for the reader's convenience only. It does not form part of the European patent document. Even though great care has been taken in compiling the references, errors or omissions cannot be excluded and the EPO disclaims all liability in this regard.*

**Patent documents cited in the description**

- EP 3822764 A1 [0010]