

(19)



(11)

EP 4 130 600 B1

(12)

EUROPEAN PATENT SPECIFICATION

(45) Date of publication and mention of the grant of the patent:
30.04.2025 Bulletin 2025/18

(21) Application number: **20926468.8**

(22) Date of filing: **23.03.2020**

(51) International Patent Classification (IPC):
F24H 9/00 (2022.01) F24H 4/02 (2022.01)

(52) Cooperative Patent Classification (CPC):
F24H 4/02; F24H 9/00; F24D 2220/0278

(86) International application number:
PCT/JP2020/012672

(87) International publication number:
WO 2021/191959 (30.09.2021 Gazette 2021/39)

(54) **HOT WATER GENERATING DEVICE**

VORRICHTUNG ZUR ERZEUGUNG VON HEISSEM WASSER

DISPOSITIF DE GÉNÉRATION D'EAU CHAUDE

(84) Designated Contracting States:
AL AT BE BG CH CY CZ DE DK EE ES FI FR GB GR HR HU IE IS IT LI LT LU LV MC MK MT NL NO PL PT RO RS SE SI SK SM TR

(43) Date of publication of application:
08.02.2023 Bulletin 2023/06

(73) Proprietor: **Carrier Japan Corporation**
Tokyo 141-0032 (JP)

(72) Inventors:
• **WAKATSUKI, Kazuhito**
Fuji-shi, Shizuoka 4168521 (JP)

• **MORIZONO, Takahiro**
Fuji-shi, Shizuoka 4168521 (JP)

(74) Representative: **Gramm, Lins & Partner**
Patent- und Rechtsanwälte PartGmbB
Frankfurter Straße 3 C
38122 Braunschweig (DE)

(56) References cited:
EP-A1- 3 358 279 GB-A- 1 370 458
JP-A- 2015 161 424 JP-A- 2016 188 732
JP-A- 2017 067 371 JP-A- 2017 067 373
JP-U- S50 134 056 US-A1- 2010 025 488
US-A1- 2017 276 405 US-B1- 10 429 097

EP 4 130 600 B1

Note: Within nine months of the publication of the mention of the grant of the European patent in the European Patent Bulletin, any person may give notice to the European Patent Office of opposition to that patent, in accordance with the Implementing Regulations. Notice of opposition shall not be deemed to have been filed until the opposition fee has been paid. (Art. 99(1) European Patent Convention).

Description

TECHNICAL FIELD

[0001] The present invention relates to a hot water generator according to the preamble of the independent claim.

BACKGROUND

[0002] A hot water supply system of a heat pump type is known as a hot water generator. This conventional hot water supply system includes an outdoor unit (i.e., heat source unit) and a hydro unit (i.e., water/heat exchange unit). The hydro unit includes: a housing; an expansion tank that is provided inside the housing that alleviates pressure rise in piping due to hot water having risen in temperature; and a water heat exchanger that exchanges heat between water and a high-temperature refrigerant supplied from the heat source unit.

PRIOR ART

[0003] EP 3 358 279 A1 discloses the features of the preamble of the independent claim. Further prior art is disclosed in US 2010/025 488 A1, JP 2017 067 371 A, GB 1 370 458 A, US 10 429 097 B1 and WO 2007/142144 A1.

SUMMARY

PROBLEMS TO BE SOLVED BY INVENTION

[0004] The hydro unit of the conventional hot water supply system generally includes a rectangular housing that has a front face, a rear face, a top face, a bottom face, and a pair of left and right side faces. The expansion tank provided in the housing is a cylindrical tank.

[0005] The rectangular tank can efficiently utilize the space inside the housing. However, the rectangular tank requires sufficient strength at the corners. Thus, the rectangular tank may be heavier and/or more expensive than the cylindrical tank that does not have a corner.

[0006] The cylindrical tank has a larger internal volume per unit weight than the rectangular tank. Thus, the cylindrical tank is cheaper and lighter than the rectangular tank having approximately the same internal volume. However, when the cylindrical tank is housed in a rectangular housing, a gap is generated between the cylindrical tank and the housing. That is, it is difficult for the cylindrical tank to efficiently utilize the space inside the housing as compared with the rectangular tank.

[0007] An object of the present invention is to provide a hot water generator that can efficiently accommodate a cylindrical expansion tank in a rectangular housing of its hydro unit.

MEANS FOR SOLVING PROBLEM

[0008] The invention is defined by the features of the independent claim. A hot water generator according to the invention includes an outdoor unit that includes therein a compressor and a heat exchanger configured to exchange heat between a refrigerant and air, a hydro unit including a water heat exchanger that exchanges heat between water and the refrigerant flowing in from the outdoor unit. The hydro unit includes a rectangular housing that has a front face, a rear face, a top face, a bottom face, and a pair of side faces, and an expansion tank that has a cylindrical shape. The expansion tank has length dimension in a centerline direction larger than diameter dimension, and is accommodated in the housing with the centerline directed toward the pair of side faces.

BRIEF DESCRIPTION OF DRAWINGS

[0009]

Fig. 1 is a system configuration diagram of a hot water generator according to one embodiment of the present invention.

Fig. 2 is a perspective view of a hydro unit of the hot water generator according to the present embodiment.

Fig. 3 is an exploded perspective view of the hydro unit of the hot water generator according to the present embodiment.

Fig. 4 is a perspective view of the internal structure of the hot water generator according to the present embodiment.

Fig. 5 is a front view of the internal structure of the hot water generator according to the present embodiment.

Fig. 6 is a longitudinal cross-sectional view of the hot water generator according to the present embodiment.

DETAILED DESCRIPTION

[0010] Embodiments of a hot water generator according to the present invention will be described by referring to Fig. 1 to Fig. 6. The same reference signs are given to identical or equivalent components in each figure.

[0011] Fig. 1 is a system configuration diagram of a hot water generator 1 according to one embodiment of the present invention.

[0012] As shown in Fig. 1, the hot water generator 1 according to the present embodiment is a heat pump type. The hot water generator 1 includes: an outdoor unit 2 that is a heat source unit configured to exchange heat between outdoor air and a refrigerant; a hydro unit 3 (i.e., water/heat exchange unit) that exchanges heat between the refrigerant and water supplied from the outside of the generator; a remote controller 4 that accepts operations by a user as an input device; and a controller 5 that

controls the outdoor unit 2 and the hydro unit 3 on the basis of the operations inputted to the remote controller 4.

[0013] The hot water generator 1 circulates the refrigerant between the outdoor unit 2 and the hydro unit 3, and heats water by exchanging heat between the refrigerant and water in a water heat exchanger 15 in the hydro unit 3 so as to supply hot water at the first temperature (for example, 40 degrees Celsius) to the outside of the generator. The hot water at the first temperature is returned to the hydro unit 3 through an external heating device (not shown) such as a floor heating system. In other words, water circulates between the hydro unit 3 and the external heat radiating device such as a heat radiator of the heating device.

[0014] In addition, the hot water generator 1 can supply high-temperature hot water at the second temperature (for example, about 70 degrees Celsius) to the outside of the generator by applying both of heat exchange between the refrigerant and water as well as heating with the use of a backup heater 67 described below. When only the heat exchange between the refrigerant and water is applied, though it depends on the type of refrigerant to be used, the maximum temperature is about 55 degrees Celsius in the case of using the R410A refrigerant. The hot water at the second temperature is stored in a hot water storage device outside the generator and then is used. The hot water stored in the hot water storage device is supplied to, for example, a washroom, a kitchen, and a bathroom. Normally, the outdoor unit 2 is installed outdoors and the hydro unit 3 is installed indoors. The outdoor unit 2 and the hydro unit 3 are interconnected by crossover pipes 21 and 22 of refrigerant piping 16 and a communication line (not shown). In the hot water generator 1 as described above, the water pipe is not laid outdoors, and thus, freezing of water in the water pipe does not occur at low temperature in winter.

[0015] The number of the included remote controller(s) 4 is one or more. For example, one remote controller 4 is installed in the hydro unit 3 and another remote controller (not shown) is installed indoors (e.g., on a wall surface).

[0016] The hot water generator 1 includes a refrigeration circuit 10. The refrigeration circuit 10 transfers heat from a low temperature portion to a high temperature portion by using outdoor air as a heat source so as to heat water into hot water.

[0017] The refrigeration circuit 10 includes: a compressor 11; an air heat exchanger 12 as an evaporator; an expansion valve 13; the water heat exchanger 15 as a condenser; and refrigerant piping 16 that connects the compressor 11, the air heat exchanger 12, the expansion valve 13, and the water heat exchanger 15 so as to circulate the refrigerant. The refrigeration circuit 10 transfers heat from the air heat exchanger 12 to the water heat exchanger 15 so as to heat the water into hot water in the water heat exchanger 15.

[0018] The refrigeration circuit 10 further includes: a four-way valve 17 that sends the refrigerant having discharged from the compressor 11 to one of the air heat

exchanger 12 and the water heat exchanger 15 and returns the refrigerant having passed through the other of the air heat exchanger 12 and the water heat exchanger 15 back to the compressor 11; and an accumulator 18 disposed in the refrigerant piping 16 between the four-way valve 17 and the compressor 11.

[0019] The water heat exchanger 15 is housed in the hydro unit 3, and the rest of the other components of the refrigeration circuit 10 are housed in the outdoor unit 2.

[0020] When the refrigeration circuit 10 heats water, the air heat exchanger 12 functions as an evaporator (also called a heat absorber) and the water heat exchanger 15 functions as a condenser (also called a radiator).

[0021] The compressor 11 compresses, boosts, and discharges the refrigerant. The compressor 11 can change the operating frequency by known inverter control. The amount of heat to be transferred to the high temperature portion increases by increasing the rotation speed of the compressor 11 and decreases by decreasing the rotation speed of the compressor 11. In addition, the power consumption of the compressor 11 increases along with the increase in the rotation speed of the compressor 11.

[0022] The expansion valve 13 is, for example, an electronic expansion valve (PMV: Pulse Motor Valve). The expansion valve 13 can adjust the valve opening degree. Although it is not shown, the expansion valve 13 includes: a valve body having a through hole; a needle that can advance and retreat with respect to the through hole; and a power source for advancing and retreating the needle, for example. When the through hole is closed with the needle, the expansion valve 13 stops, i.e., blocks the flow of the refrigerant in the refrigeration circuit 10. At this time, the expansion valve 13 is in the closed state and the opening degree of the expansion valve 13 is the smallest. When the needle is farthest from the through hole, the flow rate of the refrigerant in the refrigeration circuit 10 is maximized and the opening degree of the expansion valve 13 is the largest.

[0023] The power source of the expansion valve 13 is, for example, a stepping motor. The rotation of the stepping motor causes the needle to move forward and backward, which changes the distance to the through hole and thereby changes the opening degree.

[0024] The refrigerant piping 16 connects the compressor 11, the accumulator 18, the four-way valve 17, the air heat exchanger 12, the expansion valve 13, and the water heat exchanger 15. The refrigerant piping 16 includes: a first refrigerant pipe 16a that connects the discharge side of the compressor 11 and the four-way valve 17; a second refrigerant pipe 16b that connects the suction side of the compressor 11 and the four-way valve 17; a third refrigerant pipe 16c that connects the four-way valve 17 and the water heat exchanger 15; a fourth refrigerant pipe 16d that connects the air heat exchanger 12 and the water heat exchanger 15; and a fifth refrigerant pipe 16e that connects the air heat exchanger 12 and the four-way valve 17.

[0025] The accumulator 18 is provided on the second refrigerant pipe 16b. The expansion valve 13 is provided on the fourth refrigerant pipe 16d.

[0026] The four-way valve 17 switches the direction of the refrigerant flow in the refrigerant piping 16. When the water is heated into hot water by the refrigeration circuit 10, the four-way valve 17 circulates the refrigerant from the first refrigerant pipe 16a to the third refrigerant pipe 16c and circulates the refrigerant from the fifth refrigerant pipe 16e to the second refrigerant pipe 16b (refrigerant flow shown by the solid line in Fig. 1).

[0027] When water is heated into hot water, the hot water generator 1 discharges the compressed high-temperature and high-pressure refrigerant from the compressor 11 and then sends the refrigerant to the water heat exchanger 15 via the four-way valve 17. The water heat exchanger 15 exchanges heat between the water passing through the water heat exchanger 15 and the refrigerant passing through the water heat exchanger 15. In this manner, the water is heated and the refrigerant is cooled so as to be in a high-pressure liquid state. That is, when water is heated into hot water, the water heat exchanger 15 functions as a radiator. The refrigerant having passed through the water heat exchanger 15 passes through the expansion valve 13 and is decompressed to become a low-pressure gas-liquid two-phase refrigerant, and then reaches the air heat exchanger 12. The air heat exchanger 12 cools the outdoor air by exchanging heat between the outdoor air and the refrigerant passing through the air heat exchanger 12. At this time, the air heat exchanger 12 functions as a heat absorber that evaporates the refrigerant into a gaseous state. The refrigerant having passed through the air heat exchanger 12 is sucked into the compressor 11.

[0028] The refrigeration circuit 10 can perform defrosting operation by causing the four-way valve 17 to switch the direction of the refrigerant flow in the refrigerant piping 16. When performing the defrosting operation, the hot water generator 1 inverts the four-way valve 17 such that the flow of the refrigerant is generated in the refrigeration circuit 10 in the direction opposite to the flow of the refrigerant heating up the water into hot water. In the case of the defrosting operation, the four-way valve 17 causes the refrigerant to circulate from the first refrigerant pipe 16a to the fifth refrigerant pipe 16e and from the third refrigerant pipe 16c to the second refrigerant pipe 16b (refrigerant flow indicated by the broken line in Fig. 1). In the case of the defrosting operation, the air heat exchanger 12 functions as a condenser and the water heat exchanger 15 functions as an evaporator.

[0029] Further, the refrigeration circuit 10 may be dedicated to heating water without including the four-way valve 17. In this case, the discharge side of the compressor 11 is connected to the water heat exchanger 15 via the refrigerant piping 16, and the suction side of the compressor 11 is connected to the air heat exchanger 12 via the refrigerant piping 16.

[0030] The hydro unit 3 includes: the water heat ex-

changer 15 of the refrigeration circuit 10; an expansion tank 31 (i.e., expansion vessel); a water leading pipe 32 that leads the water before being heated from the outside of the hydro unit 3 to the water heat exchanger 15; a hot-water leading pipe 33 that leads the hot water heated by the water heat exchanger 15 to the expansion tank 31; a hot-water supplying pipe 35 that supplies the hot water heated by the water heat exchanger 15 to the outside of the hydro unit 3; a backup heater 67 that is disposed in the hot-water supplying pipe 35 and heats the hot water to be sent from the expansion tank 31 to the outside of the hot-water supplying pipe 35 up to a higher temperature; and a pump 36 that is disposed in the hot-water supplying pipe 35 and sends the hot water from the expansion tank 31 to the outside of the hydro unit 3.

[0031] The hydro unit 3 may be used for circulating hot water between the hydro unit 3 and a device outside the hydro unit 3 or may be used for heating water outside the hydro unit 3 into hot water and supplying the hot water to the outside of the hydro unit 3. The device outside the hydro unit 3 is, for example, a heating device (not shown) or a hot water storage device (not shown) that heats water using the circulating hot water and stores the water heated by the hot water.

[0032] The hydro unit 3 further includes: refrigerant pipe connection joints 25 and 26 that connect the crossover pipes 21 and 22 of the refrigerant piping 16 to the refrigerant piping 16 in the hydro unit 3; a water-leading-pipe connection joint 46 that connects a water pipe 45 outside the hydro unit 3 to the water leading pipe 32; and a hot-water pipe connection joint 48 that connects a hot-water pipe 47 outside the hydro unit 3 to the hot-water supplying pipe 35. These connection joints 25, 26, 46 and 48 are screw-in pipe joints.

[0033] The crossover pipes 21 and 22 of the refrigerant piping 16 allow the refrigerant to flow between the outdoor unit 2 and the hydro unit 3. The crossover pipe 21 is part of the third refrigerant pipe 16c and is laid outside the outdoor unit 2 and outside the hydro unit 3. The crossover pipe 22 is part of the fourth refrigerant pipe 16d and is laid outside the outdoor unit 2 and outside the hydro unit 3. The portion provided in the hydro unit 3 as part of the third refrigerant pipe 16c for connecting the refrigerator pipe connection joint 25 to the water heat exchanger 15 is referred to as a first intra-hydro-unit refrigerant pipe 27. The portion provided in the hydro unit 3 as part of the fourth refrigerant pipe 16d for connecting the refrigerant pipe connection joint 26 to the water heat exchanger 15 is referred to as a second intra-hydro-unit refrigerant pipe 28.

[0034] The hot-water pipe 47 is a crossover pipe that connects the hydro unit 3 and the hot water supply place, and the water pipe 45 is a crossover pipe that connects the hydro unit 3 and the water supply place. In the case of the circulation type, the hot water supply place and the water supply place are connected.

[0035] The hot-water leading pipe 33 connects the upstream of the pump 36 and the downstream of the

backup heater 67 in the hot-water supplying pipe 35 to the expansion tank 31. The hot-water leading pipe 33 leads the warmed and expanded hot water in the hot-water supplying pipe 35 to the expansion tank 31. The expansion tank 31 has a function of absorbing the expansion (increase in volume) of the warmed hot water.

[0036] The hot water, which is heated in the water heat exchanger 15 by the refrigerant circulating in the refrigeration circuit 10, is sucked into the hot-water supplying pipe 35 by the driven pump 36 and then is supplied to the hot water supply place through the hot-water pipe 47 outside the hydro unit 3.

[0037] Fig. 2 is a perspective view of the hydro unit 3 when viewed from the diagonally right front and from below.

[0038] Fig. 3 is an exploded perspective view of the hydro unit 3 when viewed from the diagonally right front and from above.

[0039] As shown in Fig. 2 and Fig. 3, the hydro unit 3 of the hot water generator 1 according to the present embodiment includes a longitudinally elongated rectangular housing 51.

[0040] The housing 51 has a front face 51f, a rear face 51r, a top face 51t, a bottom face 51b, and a pair of side faces 51s. The housing 51 includes: a front plate 52 that covers the front face 51f; a rear plate 53 that covers the rear face 51r, a top plate 54 that covers the top face 51t; a bottom plate 55 that covers the bottom face 51b; and a pair of side plates 56 and 57 that cover the respective side faces 51s.

[0041] The housing 51 accommodates the expansion tank 31, the water leading pipe 32, the hot-water leading pipe 33, the hot-water supplying pipe 35, the pump 36, the water heat exchanger 15 of the refrigeration circuit 10, the first intra-hydro-unit refrigerant pipe 27, and the second intra-hydro-unit refrigerant pipe 28.

[0042] The housing 51 further accommodates: a controller accommodation box 61 that houses the controller 5; and a controller supporting plate 62 that supports the controller accommodation box 61 inside the housing 51. The controller accommodation box 61 is a box that opens toward the front of the housing 51. In the controller accommodation box 61, a board on which the controller 5 is mounted is supported.

[0043] The front plate 52 has an operation window 63 for disposing the remote controller 4. The back side of the front plate 52 is provided with a controller supporting plate 65 that supports the remote controller 4 disposed in the operation window 63. The controller supporting plate 65 has a function of a lid that covers the controller accommodation box 61.

[0044] The front plate 52, the rear plate 53, the top plate 54, the bottom plate 55, the side plates 56 and 57, the controller accommodation box 61, the controller supporting plate 62, and the controller supporting plate 65 are processed sheet metal products.

[0045] The water leading pipe 32, the hot-water leading pipe 33, the hot-water supplying pipe 35, the pump 36,

the water heat exchanger 15 of the refrigeration circuit 10, the first intra-hydro-unit refrigerant pipe 27, and the second intra-hydro-unit refrigerant pipe 28 are disposed in the space that is sandwiched between the rear plate 53 and the controller supporting plate 62. The expansion tank 31 is disposed in the space that is above the controller supporting plate 62 and sandwiched between the front plate 52 and the rear plate 53.

[0046] As shown in Fig. 2 to Fig. 5, the rear plate 53 of the housing 51 in the hot water generator 1 according to the present embodiment supports the expansion tank 31 and the water heat exchanger 15 of the refrigeration circuit 10.

[0047] The expansion tank 31 has a cylindrical shape in which the length L in the direction of the centerline C is larger in dimension than the diameter D. The expansion tank 31 is housed in the housing 51 such that the centerline C is oriented in the direction toward the pair of side faces 51s. In other words, the length L of the expansion tank 31 is smaller in dimension than the width of the housing 51. Further, the diameter D of the expansion tank 31 is smaller in dimension than the height and the depth of the housing 51. The expansion tank 31 is disposed at the uppermost part of the housing 51. The expansion tank 31 includes a cylindrical body 31a and a pair of end plates 31b and 31c that close both ends of the body 31a. The expansion tank 31 is fixed to the rear plate 53 by a saddle-shaped tank fixing band 66 extending on the body 31a. The tank fixing band 66 fixes the expansion tank 31 to the rear plate 53 like a saddle band used for fixing pipes. That is, the tank fixing band 66 is bent along the body 31a from the upper part to the lower part of the body 31a so as to fix the expansion tank 31 to the rear plate 53 of the housing 51.

[0048] The water leading pipe 32, the hot-water leading pipe 33, the hot-water supplying pipe 35, the pump 36, the water heat exchanger 15 of the refrigeration circuit 10, the first intra-hydro-unit refrigerant pipe 27, and the second intra-hydro-unit refrigerant pipe 28 are disposed below the expansion tank 31.

[0049] The water heat exchanger 15 is disposed directly under the expansion tank 31 and near the side plate 56 on one of the left and right sides of the housing 51 (on the left side, in this case). The backup heater 67 is disposed directly under the expansion tank 31 and near the side plate 57 on the other of the left and right sides of the housing 51 (on the right side, in this case). The backup heater 67 is fixed to the rear plate 53. Under the circumstances where the outside temperature is so extremely low that heating the water into hot water by the refrigeration circuit 10 is difficult, the backup heater 67 is used for assisting the heating of water and for further heating the hot water that is already heated by the refrigeration circuit 10 into hotter water.

[0050] The pump 36 is disposed below the expansion tank 31, directly in front of the backup heater 67, and on the bottom plate 55 of the housing 51. Directly below the pump 36, the hot-water pipe connection joint 48 is pro-

vided. The hot-water pipe connection joint 48 protrudes toward the outside of the housing 51. The hot-water pipe connection joint 48 protrudes downward from the bottom plate 55 so as to be exposed to the outside of the housing 51.

[0051] The water-leading-pipe connection joint 46 is provided behind the obliquely left side of the hot-water pipe connection joint 48. The water leading pipe 32 connected to the water-leading-pipe connection joint 46 bends toward the water heat exchanger 15 at the portion that enters the back side of the housing 51 from the bottom plate 55 of the housing 51, extends in the vicinity of the bottom plate 55 in parallel to the bottom plate 55, and is connected to the back side of the lower end of the right side-face of the water heat exchanger 15. The hot-water supplying pipe 35 is connected to the back side of the upper end of the right side-face of the water heat exchanger 15. The hot-water supplying pipe 35 extends from the water heat exchanger 15 toward the side plate 57 of the housing 51, bends at an intermediate position between the water heat exchanger 15 and the backup heater 67 toward the bottom plate 55 of the housing 51, hangs directly downward so as to extend in parallel to the bottom plate 55 at a portion reaching the lower end of the backup heater 67, and is connected to the lower end of the left side-face of the backup heater 67. The hot-water leading pipe 33 branches from the hot-water supplying pipe 35 via a cross-shaped branch at the upper end of the front face of the backup heater 67, rises toward the top face plate 54 of the housing 51, reaches substantially the same height as the centerline C of the expansion tank 31, and bypasses the front of the expansion tank 31 so as to be connected to the end plate 31b on the left side of the expansion tank 31.

[0052] The hot-water supplying pipe 35 extends downward from the cross-shaped branch so as to reach the pump 36. That is, the pump 36 is connected to the outlet end of the hot-water supplying pipe 35.

[0053] The first intra-hydro-unit refrigerant pipe 27 and the second intra-hydro-unit refrigerant pipe 28 enter the housing 51 through a refrigerant-pipe insertion hole 71 provided on the bottom plate 55 of the housing 51.

[0054] The first intra-hydro-unit refrigerant pipe 27 extends on the right side of the water heat exchanger 15 toward the expansion tank 31, bends toward the water heat exchanger 15 near the front of the upper end of the right side-face of the water heat exchanger 15, and is connected to the water heat exchanger 15. The first intra-hydro-unit refrigerant pipe 27 rises and extends almost directly in front of the hanging portion of the hot-water supplying pipe 35. The refrigerant pipe connection joint 25 is provided at the end of the first intra-hydro-unit refrigerant pipe 27 disposed outside the housing 51.

[0055] The second intra-hydro-unit refrigerant pipe 28 rises in parallel to the first intra-hydro-unit refrigerant pipe 27 in the vicinity closer to the water heat exchanger 15 than the first intra-hydro-unit refrigerant pipe 27, bends toward the water heat exchanger 15 near the front of the

lower end of the right side-face of the water heat exchanger 15, and is connected to the water heat exchanger 15. The refrigerant pipe connection joint 26 is provided at the end of the second intra-hydro-unit refrigerant pipe 28 disposed outside the housing 51.

[0056] Next, the fixing structure of the expansion tank 31 will be described.

[0057] Fig. 6 is a longitudinal cross-sectional view of the hot water generator according to the present embodiment.

[0058] As shown in Fig. 6 in addition to Fig. 4 and Fig. 5, the expansion tank 31 of the hot water generator 1 according to the present embodiment includes at least one convex part 81 that protrudes outward in the radial direction of the cylindrical body 31a and extends in the circumferential direction of the body 31a.

[0059] The convex parts 81 annularly circle the body 31a and are connected in a row. The number of the convex parts 81 is two or more including the first convex part 81a and the second convex part 81b. The convex parts 81 are, for example, joint parts that join two members to form an integrated body 31a or holding parts that hold diaphragms (not shown) in the expansion tank 31 on the inner circumferential face of the body 31a. The plurality of convex parts 81a and 81b are separated from each other in the direction of the centerline of the expansion tank 31 and are arranged in parallel.

[0060] The convex parts 81 may be provided in the body 31a annularly and discretely (i.e., discontinuously or at intervals).

[0061] The tank fixing band 66 may be in a shape of hexagonal saddle as shown in Fig. 4 to Fig. 6, may be in a shape of polygonal saddle such as triangular, rectangular, and pentagonal saddles, or may be in a shape of arc-shaped saddle. The hexagonal saddle-shaped tank fixing band 66 has: a first part 66a that is in contact with the top of the expansion tank 31 and is fixed to the rear plate 53; a second part 66b that is continuous with the first part 66a and slopes down toward the front of the expansion tank 31 while partially contacting the expansion tank 31; a third part 66c that is continuous with the second part 66b and is located in front of the expansion tank 31 while partially contacting the expansion tank 31; a fourth part 66d that is continuous with the third part 66c and slopes down toward the bottom of the expansion tank 31 while partially contacting the expansion tank 31; a fifth part 66e that is continuous with the fourth 66d and is fixed to the rear plate 53 so as to be in contact with the bottom of the expansion tank 31.

[0062] The tank fixing band 66 has at least one hole 82 that is interdigitated with the convex part 81. The respective holes 82 are provided at positions where the convex parts 81 can be fitted from one end to the other end of the tank fixing band 66. The plurality of holes 82 are arranged and include: a first hole 82a into which the first convex part 81a is fitted; and a second hole 82b into which the second convex part 81b is fitted. The plurality of holes 82a and 82b are separated from each other in the band

width direction of the tank fixing band 66 and are arranged in parallel.

[0063] In the polygonal saddle-shaped tank fixing band 66, the holes 82 are preferably provided discretely (i.e., discontinuously or at intervals) so as to avoid the vertices as shown in Fig. 4 to Fig. 6. In this case, the tank fixing band 66 can readily obtain sufficient strength for supporting the expansion tank 31. In the hexagonal saddle-shaped tank fixing band 66, the holes 82 are discretely provided from the first part 66a to the fifth part 66e of the tank fixing band 66 and are interrupted at the ridges connecting the respective parts 66a to 66e.

[0064] The rear plate 53 includes: a band fixing hole 85 provided above the expansion tank 31; a band fastening hole 86 provided below the expansion tank 31; and a pair of anti-rolling stoppers 87 that prevents the expansion tank 31 from rolling against the rear plate 53.

[0065] The band fastening hole 86 is provided in the flange 53a for fixing the top plate 54 to the rear plate 53.

[0066] The pair of anti-rolling stoppers 87 are disposed below the band fixing hole 85 and above the band fastening hole 86 and have a convex shape extending in a direction parallel to the longitudinal direction of the expansion tank 31. The expansion tank 31 is in contact with the rear plate 53 at the portion sandwiched between the pair of anti-rolling stoppers 87. It is preferred that the expansion tank 31 is also in contact with the pair of anti-rolling stoppers 87.

[0067] The tank fixing band 66 has: a folded part 66f that is inserted into the band fixing hole 85 of the rear plate 53; and a flange 66g that is fixed to the band fastening hole 86 by a fastening member 89. The folded part 66f is provided at the upper end part of the tank fixing band 66, i.e., at the root part of the first part 66a. The folded part 66f is a cut-up formed on the tank fixing band 66, which is a processed sheet metal product, and is formed by bending a material of this sheet product. The flange 66g is provided at the lower end of the tank fixing band 66, i.e., at the root part of the fifth part 66e.

[0068] In addition to or instead of the folded part 66f, a fastening member may be used for fixing the root part of the first part 66a of the tank fixing band 66, which has the folded part 66f, to the flange 53a of the rear plate 53.

[0069] As shown by the two-dot chain line in Fig. 5, when the expansion tank 31 is housed in the housing 51 in such a manner that the centerline C of the cylindrical expansion tank 31 matches the up-and-down direction of the housing 51, the height dimension of the housing 51 significantly increases.

[0070] The depth dimension of the housing 51 depends on the diameter dimension D of the expansion tank 31 and does not change substantially regardless of whether the accommodation state of the expansion tank 31 in the housing 51 is an upright state or a lying state. Since the width dimension of the housing 51 depends on the size and disposition of devices in the housing 51 excluding the expansion tank 31, when the expansion tank 31 is housed in the housing 51 in the upright state, a

large-capacity space in which no device is placed, i.e., so-called dead space is generated in the housing 51. When the expansion tank 31 is housed in the housing 51 in the state of being laid down, the width dimension of the housing 51 can be effectively utilized as shown in Fig. 5. That is, when the expansion tank 31 is accommodated in the housing 51 in the lying state, the height dimension of the housing 51 can be suppressed and the hydro unit 3 can be miniaturized. Further, when the expansion tank 31 is accommodated in the housing 51 in the lying state, the length L of the expansion tank 31 is extended to the extent that the expansion tank 31 fits within the width dimension of the housing 51, and thus, the internal volume of the expansion tank 31 is expanded.

[0071] As described above, the hot water generator 1 according to the present embodiment includes the cylindrical expansion tank 31 that has the length L in the direction of the centerline C larger in dimension than the diameter D and is housed in the housing 51 with its centerline C directed toward the pair of side faces 51s of the housing 51. Hence, the hot water generator 1 can accommodate the cylindrical expansion tank 31, which is cheaper and lighter than a rectangular tank having almost the same internal volume, and can efficiently utilize the space in the housing 51. As a result, the hydro unit 3 of the hot water generator 1 can be small and lightweight that provides a satisfactory appearance, high workability at the time of installation, and small occupation space in the installed state.

[0072] In addition, the hot water generator 1 according to the present embodiment includes the expansion tank 31 disposed in the uppermost part of the housing 51. Thus, in the hot water generator 1, the size of the hydro unit 3 can be reduced while the expansion tank 31 and other devices to be housed in the housing 51 can be efficiently disposed.

[0073] Further, the hot water generator 1 according to the present embodiment includes the tank fixing band 66 that has the holes 82 to be interdigitated with the convex parts 81 of the expansion tank 31 and fixes the expansion tank 31 to the rear plate 53 of the housing 51 by extending on the body 31a of the expansion tank 31 from above to below the body 31a. Hence, the hot water generator 1 can reliably fix the expansion tank 31 at a predetermined position and prevent the installation position of the expansion tank 31 from shifting.

[0074] Moreover, the hot water generator 1 according to the present embodiment includes: the pair of anti-rolling stoppers 87 that prevents the expansion tank 31 from rolling against the rear plate 53; and the tank fixing band 66 that has the folded part 66f to be inserted into the band fixing hole 85 of the rear plate 53 and the flange 66g to be fixed to the band fastening hole 86 of the rear plate 53 by the fastening member 89. Thus, the hot water generator 1 can readily and firmly fix the expansion tank 31 to the rear plate 53.

[0075] According to the hot water generator 1 of the present embodiment, the cylindrical expansion tank 31

can be efficiently accommodated in the rectangular housing 51.

REFERENCE SIGNS LIST

[0076]

1	hot water generator	
2	outdoor unit	
3	hydro unit	10
15	water heat exchanger	
27	first intra-hydro-unit refrigerant pipe	
28	second intra-hydro-unit refrigerant pipe	
31	expansion tank	
31a	body	15
31b, 31c	end plate	
51	housing	
51f	front face	
51r	rear face	
51t	top face	20
51b	bottom face	
51s	side face	
52	front plate	
53	rear plate	
53a	flange	25
54	top plate	
55	bottom plate	
56, 57	side plate	
66	tank fixing band	
66a	first part	30
66b	second part	
66c	third part	
66d	fourth part	
66e	fifth part	
66f	folded part	35
66g	flange	
67	backup heater	
81	convex part	
82	hole	
85	band fixing hole	40
86	band fastening hole	
87	anti-rolling stopper	
89	fastening member	

Claims

1. A hot water generator (1) comprising:

an outdoor unit (2) that includes therein a compressor (11) and a heat exchanger (12), the heat exchanger (12) being configured to exchange heat between a refrigerant and air; and a hydro unit (3) including

a water heat exchanger (15) that exchanges heat between water and the refrigerant flowing in from the outdoor unit, a rectangular housing (51) that has a front

face (51f), a rear face (51r), a top face (51t), a bottom face (51b), and a pair of side faces (51s), and

an expansion tank (31) that has a cylindrical shape, the expansion tank (31) having a length dimension in a centerline direction larger than diameter dimension, and being accommodated in the housing (51) with the centerline directed toward the pair of side faces (51s), **characterized in that** the expansion tank (31) includes a cylindrical body (31a), and a convex part (81) that protrudes outward in a radial direction of the cylindrical body (31a) and extends in a circumferential direction of the cylindrical body (31a), and **in that**

the hot water generator (1) further comprises a fixing band (66) that has a hole (82) configured to be interdigitated with the convex part (81), and fixes the expansion tank (31) to a rear plate (53) that forms the rear face (51r) of the housing (51), in a manner that the fixing band (66) extends on the cylindrical body (31a) from above to below the cylindrical body (31a).

2. The hot water generator (1) according to claim 1, wherein the expansion tank (31) is disposed in an uppermost part of the housing (51).

3. The hot water generator according to claim 1 or 2, wherein:

the rear plate (53) includes a band fixing hole (85) provided above the expansion tank (31), a band fastening hole (86) provided below the expansion tank (31), and a pair of anti-rolling stoppers (87) configured to prevent the expansion tank (31) from rolling against the rear plate (53); and

the fixing band (66) has a folded part (66f) configured to be inserted into the band fixing hole (85), and a flange (66a) configured to be fixed to the band fastening hole (86) by a fastening member (89).

Patentansprüche

1. Warmwassererzeuger (1), umfassend:

eine Außeneinheit (2), die einen Kompressor (11) und einen Wärmetauscher (12) enthält, wobei der Wärmetauscher (12) so konfiguriert ist, dass er Wärme zwischen einem Kältemittel und Luft austauscht; und eine Hydroeinheit (3), umfassend

einen Wasserwärmetauscher (15), der Wärme zwischen Wasser und dem von der Außeneinheit einströmenden Kältemittel austauscht,
 ein rechteckiges Gehäuse (51), das eine Vorderseite (51f), eine Rückseite (51r), eine Oberseite (51t), eine Unterseite (51b) und ein Paar Seitenflächen (51s) aufweist, und einen Ausdehnungsbehälter (31) mit einer zylindrischen Form,

wobei der Ausdehnungsbehälter (31) eine Längenabmessung in einer Mittellinienrichtung aufweist, die größer ist als die Durchmesserabmessung, und angeordnet ist in dem Gehäuse (51) mit der Mittellinie gerichtet zu dem Paar von Seitenflächen (51s) untergebracht ist, **dadurch gekennzeichnet, dass**

der Ausdehnungsbehälter (31) einen zylindrischen Körper (31a) und einen konvexen Teil (81) umfasst, der in einer radialen Richtung des zylindrischen Körpers (31a) nach außen vorsteht und sich in einer Umfangsrichtung des zylindrischen Körpers (31a) erstreckt, und dadurch, dass der Heißwassererzeuger (1) ferner ein Befestigungsband (66) umfasst, das ein Loch (82) aufweist, das so konfiguriert ist, dass es mit dem konvexen Teil (81) ineinandergreift, und das den Ausdehnungsbehälter (31) an einer Rückplatte (53), die die Rückseite (51r) des Gehäuses (51) bildet, so befestigt, dass sich das Befestigungsband (66) auf dem zylindrischen Körper (31a) von oberhalb bis unterhalb des zylindrischen Körpers (31a) erstreckt.

2. Warmwassererzeuger (1) nach Anspruch 1, wobei der Ausdehnungsbehälter (31) in einem obersten Teil des Gehäuses (51) angeordnet ist.
3. Warmwassererzeuger nach Anspruch 1 oder 2, wobei:
 - die hintere Platte (53) ein oberhalb des Ausdehnungsgefäßes (31) vorgesehene Bandbefestigungsloch (85), ein unterhalb des Ausdehnungsgefäßes (31) vorgesehene Bandbefestigungsloch (86) und ein Paar Anti-Roll-Anschläge (87) umfasst, die so konfiguriert sind, dass sie verhindern, dass das Ausdehnungsgefäß (31) gegen die hintere Platte (53) rollt; und
 - das Befestigungsband (66) ein gefaltetes Teil (66f) aufweist, das ausgebildet ist, um es in das Bandbefestigungsloch (85) eingesetzt zu werden, und einen Flansch (66a), der ausgebildet ist, durch ein Befestigungselement (89) an dem Bandbefestigungsloch (86) befestigt zu werden.

Revendications

1. Générateur d'eau chaude (1) comprenant :

une unité externe (2) qui inclut à l'intérieur de celle-ci un compresseur (11) et un échangeur de chaleur (12), l'échangeur de chaleur (12) étant configuré pour échanger de la chaleur entre un réfrigérant et de l'air ; et
 une hydro-unité (3) incluant

un échangeur de chaleur à eau (15) qui échange de la chaleur entre de l'eau et le réfrigérant s'écoulant depuis l'unité externe,

un logement rectangulaire (51) qui a une face avant (51f), une face arrière (51r), une face de sommet (51t), une face de fond (51b), et une paire de faces latérales (51s), et

un réservoir d'expansion (31) qui a une forme cylindrique, le réservoir d'expansion (31) ayant une dimension de longueur dans une direction de ligne centrale plus grande qu'une dimension de diamètre, et qui est reçu dans le logement (51) avec la ligne centrale dirigée vers la paire de faces latérales (51s), **caractérisé en ce que**

le réservoir d'expansion (31) inclut un corps cylindrique (31a), et une partie convexe (81) qui se projette vers l'extérieur dans une direction radiale du corps cylindrique (31a) et s'étend dans une direction circonférentielle du corps cylindrique (31a), et **en ce que**

le générateur d'eau chaude (1) comprend en outre une bande de fixation (66) qui a un trou (82) configuré pour être entrecroisé avec la partie convexe (81), et qui fixe le réservoir d'expansion (31) à une plaque arrière (53) qui forme la face arrière (51r) du logement (51), de telle manière que la bande de fixation (66) s'étend sur le corps cylindrique (31a) depuis le dessus jusqu'en dessous du corps cylindrique (31a).

2. Générateur d'eau chaude (1) selon la revendication 1, dans lequel le réservoir d'expansion (31) est disposé dans une partie la plus en haut du logement (51).

3. Générateur d'eau chaude selon la revendication 1 ou 2, dans lequel :

la plaque arrière (53) inclut un trou de fixation de bande (85) prévu au-dessus du réservoir d'expansion (31), un trou d'attache de bande (86) prévu en dessous du réservoir d'expansion (31),

et une paire de butées anti-roulement (87) configurées pour empêcher le réservoir d'expansion (31) de rouler contre la plaque arrière (53) ; et la bande de fixation (66) a une partie repliée (66f) configurée pour être insérée dans le trou de fixation de bande (85), et une bride (66a) configurée pour être fixée au le trou d'attache de bande (86) via un élément d'attache (89).

5

10

15

20

25

30

35

40

45

50

55

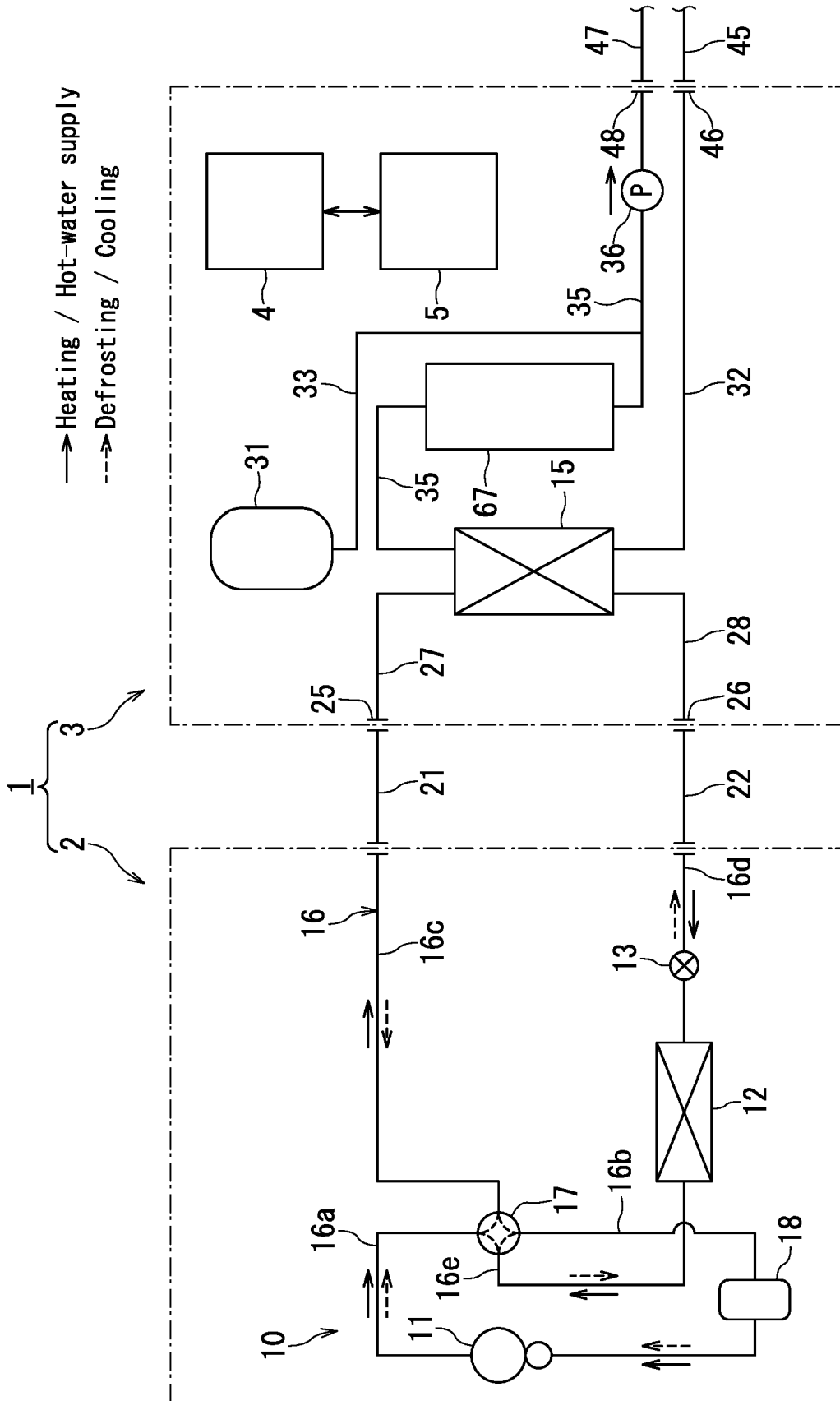

FIG. 1

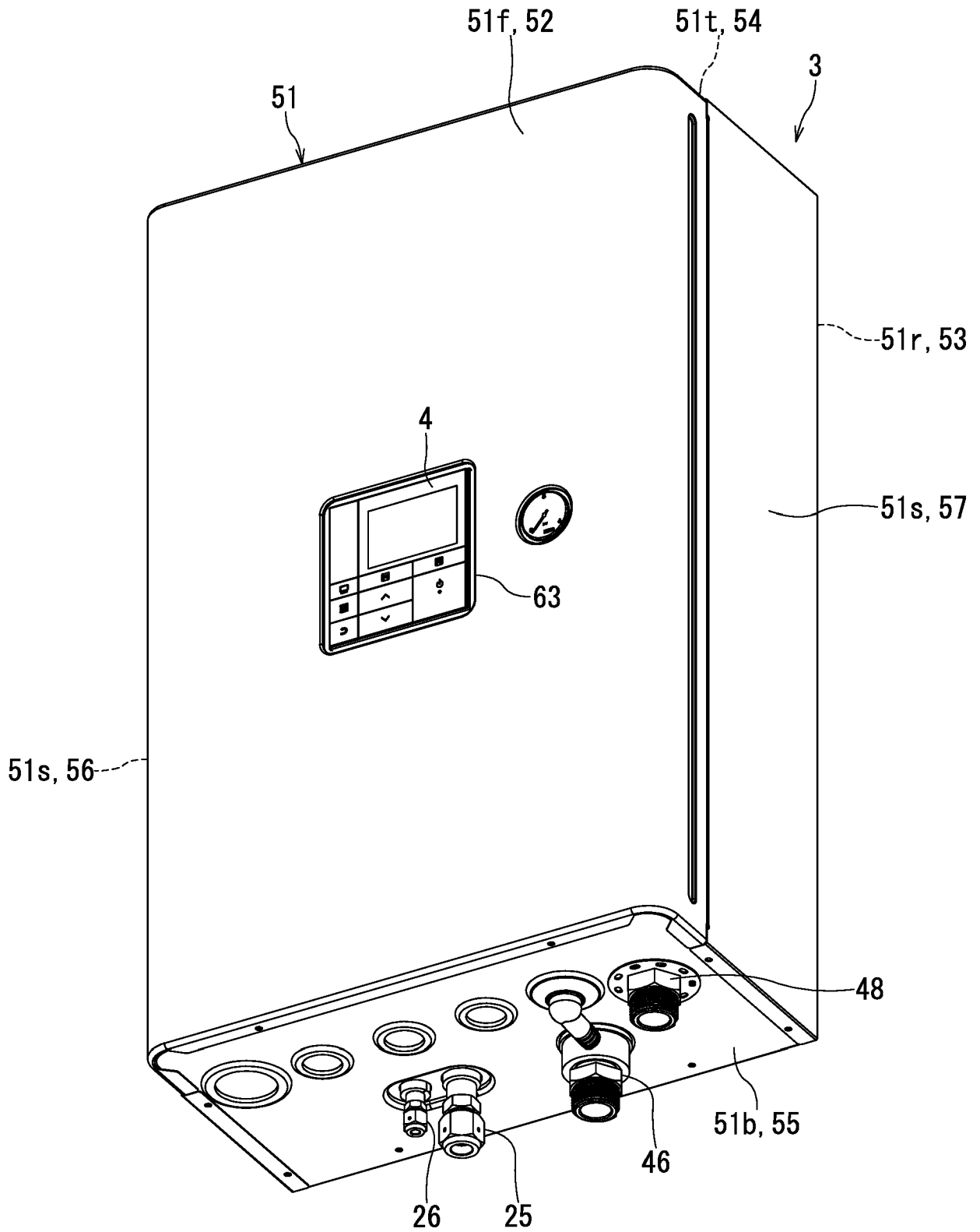

FIG. 2

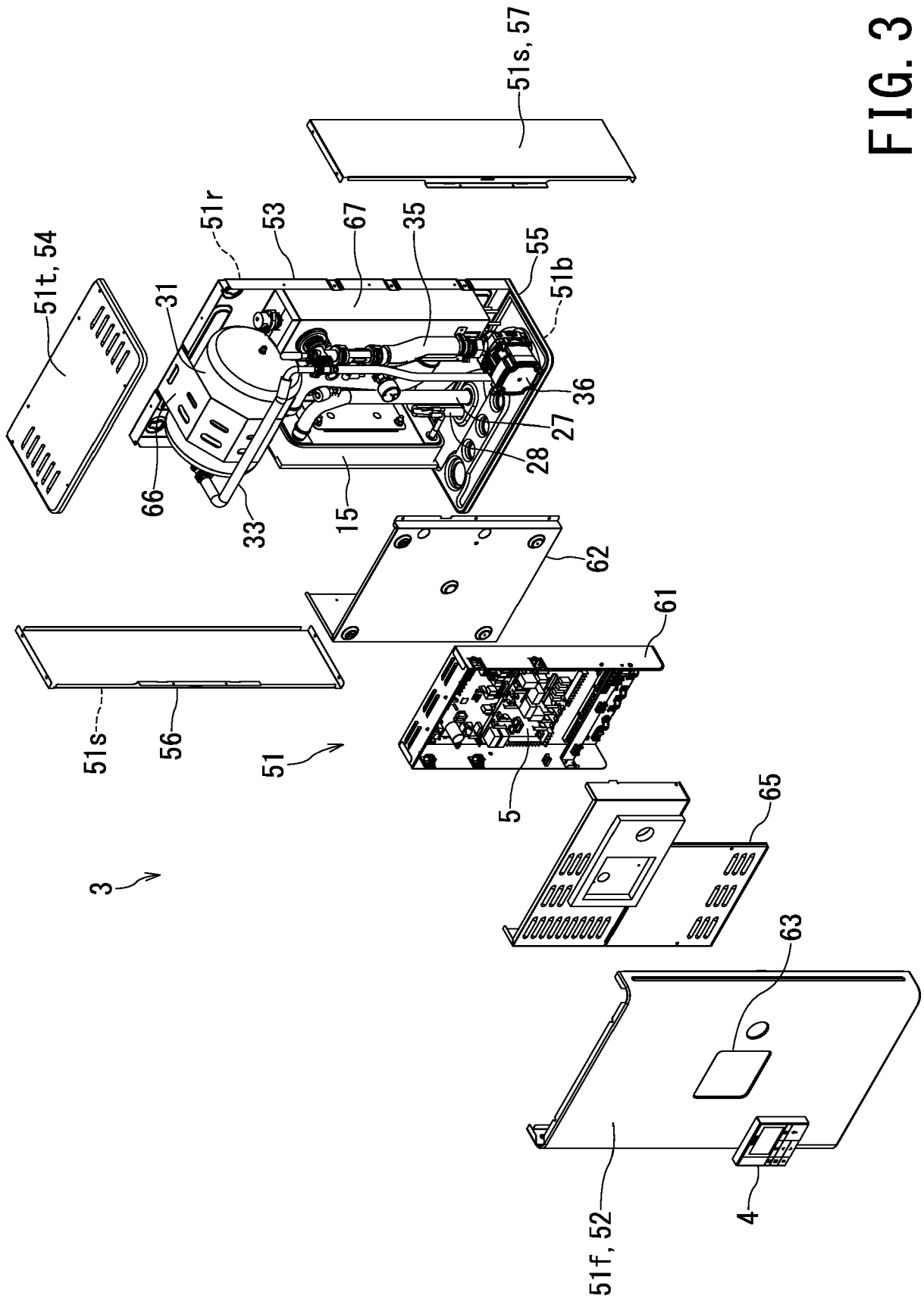

FIG. 3

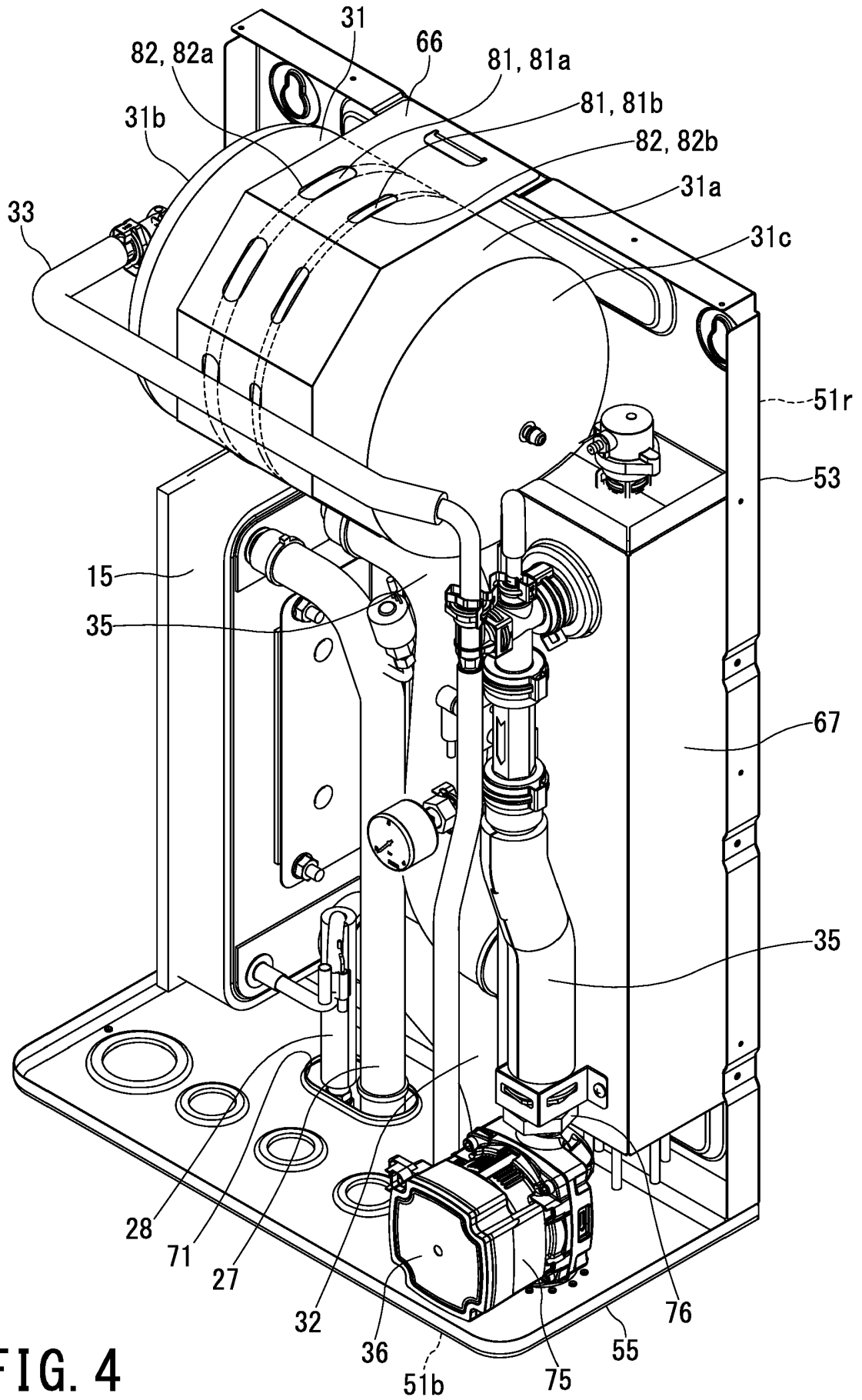

FIG. 4

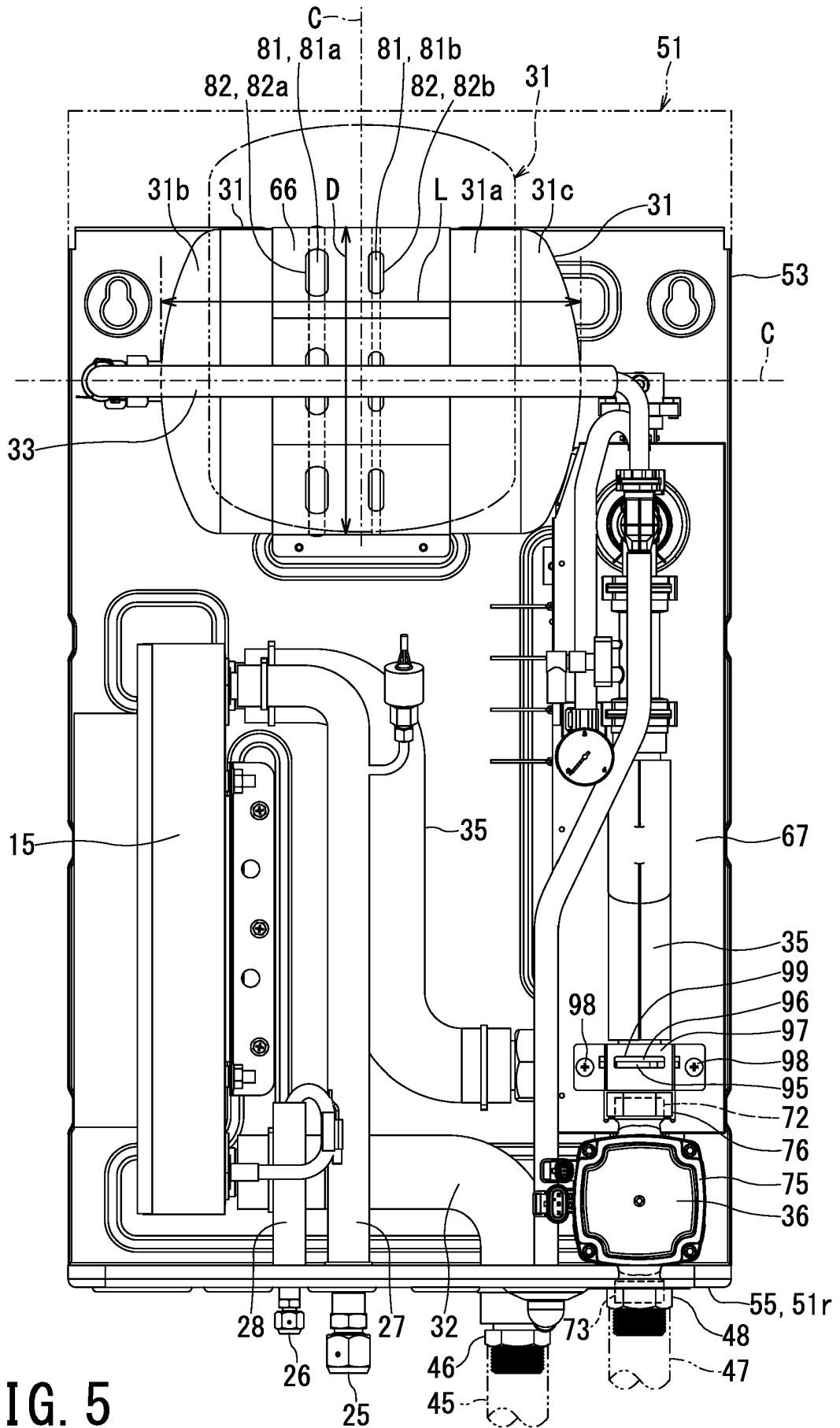

FIG. 5

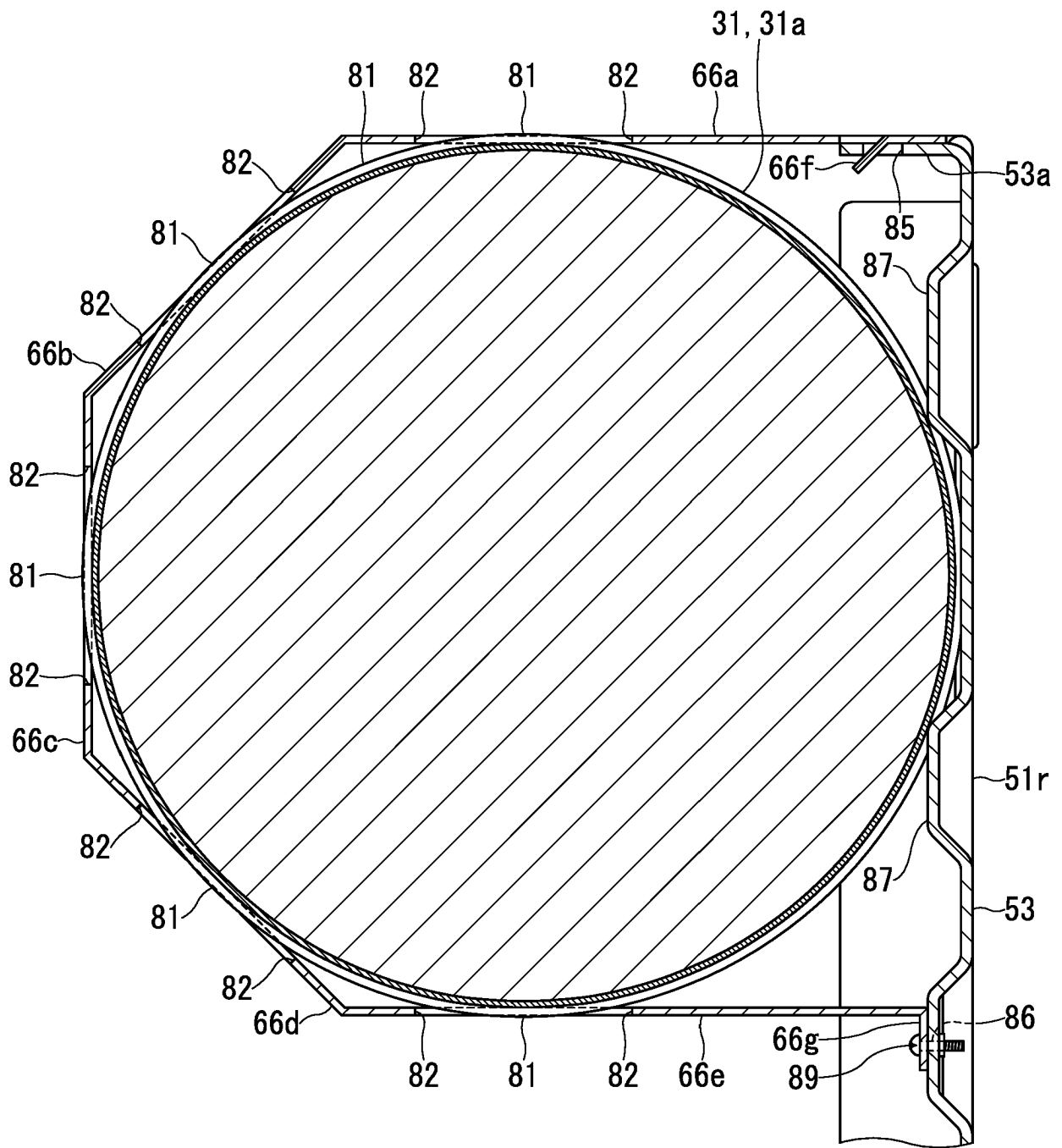

FIG. 6

REFERENCES CITED IN THE DESCRIPTION

This list of references cited by the applicant is for the reader's convenience only. It does not form part of the European patent document. Even though great care has been taken in compiling the references, errors or omissions cannot be excluded and the EPO disclaims all liability in this regard.

Patent documents cited in the description

- EP 3358279 A1 [0003]
- US 2010025488 A1 [0003]
- JP 2017067371 A [0003]
- GB 1370458 A [0003]
- US 10429097 B1 [0003]
- WO 2007142144 A1 [0003]