

(19)



(11)

EP 4 150 595 B1

(12)

EUROPEAN PATENT SPECIFICATION

(45) Date of publication and mention of the grant of the patent:
20.11.2024 Bulletin 2024/47

(21) Application number: **21735423.2**

(22) Date of filing: **13.05.2021**

(51) International Patent Classification (IPC):
G07F 17/12 ^(2006.01) **G07F 7/06** ^(2006.01)
G07F 9/10 ^(2006.01) **G07F 11/16** ^(2006.01)
G07F 11/62 ^(2006.01) **G07F 17/00** ^(2006.01)
B65G 1/04 ^(2006.01)

(52) Cooperative Patent Classification (CPC):
G07F 9/105; G07F 7/069; G07F 9/10;
G07F 11/1653; G07F 11/62; G07F 17/0071;
G07F 17/12

(86) International application number:
PCT/IT2021/050143

(87) International publication number:
WO 2021/229623 (18.11.2021 Gazette 2021/46)

(54) **APPARATUS FOR DISTRIBUTING ARTICLES**

VORRICHTUNG ZUM VERTEILEN VON GEGENSTÄNDEN

APPAREIL DE DISTRIBUTION D'ARTICLES

(84) Designated Contracting States:
AL AT BE BG CH CY CZ DE DK EE ES FI FR GB
GR HR HU IE IS IT LI LT LU LV MC MK MT NL NO
PL PT RO RS SE SI SK SM TR

(30) Priority: **15.05.2020 IT 202000011251**

(43) Date of publication of application:
22.03.2023 Bulletin 2023/12

(73) Proprietor: **Frescolock Srl**
33033 Codroipo (IT)

(72) Inventors:
• **SACCON, Fabio**
33033 CODROIPO (IT)
• **DEGANO, Riccardo**
33030 TALMASSONS (IT)

(74) Representative: **Petraz, Gilberto Luigi et al**
GLP S.r.l.
Viale Europa Unita, 171
33100 Udine (IT)

(56) References cited:
US-A1- 2015 291 357 US-A1- 2018 244 469

EP 4 150 595 B1

Note: Within nine months of the publication of the mention of the grant of the European patent in the European Patent Bulletin, any person may give notice to the European Patent Office of opposition to that patent, in accordance with the Implementing Regulations. Notice of opposition shall not be deemed to have been filed until the opposition fee has been paid. (Art. 99(1) European Patent Convention).

Description

FIELD OF THE INVENTION

[0001] Embodiments described here concern an apparatus for distributing articles, used for the storage and subsequent distribution to users of articles, such as foodstuffs, basic necessities, over-the-counter drugs, and more generally products managed by large-scale retail channels.

[0002] The apparatus can be located in any public or private space, for example, in shopping centers, service stations, supermarkets, other points of sale, or in suitable dedicated public spaces of any small or large urban center, such as, by way of example, in a parking lot with sizes corresponding to a parking space.

BACKGROUND OF THE INVENTION

[0003] Automatic distributors for articles and self-service apparatuses to pick up previously ordered articles are known. Known automatic distributors are placed by a service manager at any point of sale, service station, public or private company or in a dedicated public space.

[0004] These automatic distributors usually have a closed structure with a withdrawal door and, in some cases, a transparent front panel to view the goods contained therein. Furthermore, inside the structure there is a plurality of housings disposed in rows and columns, where the articles to be picked up are disposed. The housings are, in general, of homogeneous sizes. The goods are dispensed following the introduction into the distributor of means of payment such as coins, banknotes or suitable magnetic "keys".

[0005] The automatic distributor can be refrigerated internally.

[0006] A first disadvantage of conventional automatic distributors is that the articles available are limited only to certain product categories, on the basis of the choice made by the manager and on the basis of the defined sizes of the housings.

[0007] Another disadvantage of known automatic distributors is the need for the user to always have the correct means of payment available for that specific distributor.

[0008] It is also a disadvantage that the article already paid for can jam in the mechanism of the apparatus, preventing delivery.

[0009] Another disadvantage of these automatic distributors is that they are easily exposed and subject to acts of vandalism and theft if located in unsupervised public spaces.

[0010] There are also known self-service withdrawal apparatuses for articles ordered by a user via the web platform or by telephone.

[0011] These self-service withdrawal apparatuses for articles are located by the distribution service manager at any point of sale, service station, inside a condominium

or in a dedicated public space.

[0012] These are essentially apparatuses consisting of a metal structure in which there is a plurality of compartments, of different sizes, in the shape of a box, each of which is closed by a door, and disposed side by side to form a cabinet. The apparatuses also comprise a control unit that also acts as a user interface, to manage the withdrawal of the articles.

[0013] Each box is filled by the distribution service manager based on the individual order placed by each user.

[0014] In order to collect the articles ordered, the user is notified of a unique alphanumeric or QR (Quick Response) code that allows him/her to open the box relating to the order placed, once recognized by the control unit, by means of the user interface.

[0015] Payment can be made by prepaid account, credit card or when the articles are collected.

[0016] One disadvantage of these self-service article withdrawal apparatuses is that they are not suitable for the distribution of perishable foodstuffs or foodstuffs which, in any case, need to be stored in a controlled temperature environment. Furthermore, another disadvantage is fact that all the compartments are directly exposed to possible acts of vandalism and/or theft.

[0017] Finally, these self-service article withdrawal apparatuses are not automated, therefore the withdrawal of the articles occurs by manually opening and closing the door of the boxes that make up the apparatus, with the possibility that the closure of the box after withdrawal is not guaranteed.

[0018] These self-service article withdrawal apparatuses can also consist of a simple cabinet, with a metal structure, possibly refrigerated, having a single transparent door for access to a series of internal shelves, on which the articles ordered by the user are disposed by the manager. This solution does not guarantee security from unauthorized and fraudulent withdrawals.

[0019] Finally, these apparatuses, which like the previous ones are exposed to possible acts of vandalism and theft, are located almost exclusively inside condominiums, limiting their field of application to foodstuffs.

[0020] In summary, a disadvantage common to known apparatuses for distributing articles is that it is impossible to automatically distribute all the basic food articles managed by large-scale retail channels.

[0021] Moreover, another disadvantage of known apparatuses for distributing articles is the need for power provided by the electrical network, so that in the event of an interruption in the supply of electricity, the withdrawal of the articles desired/ordered by the user is prevented.

[0022] Document US 2015/291357 A1 discloses a retail facility for enabling customers to pick up products including perishable items, having a storage system for storing containers arranged in multiple rows at various horizontal levels with respect to ground. The storage system includes a first storage section for storing containers with products at a first temperature and a second storage

section for storing containers with products at a second temperature higher than the first temperature. The first storage section is covered with a first thermal insulating cover. A transportation device is configured for moving along one or more horizontal rails arranged above the first storage section. The rails are supported by vertical support elements arranged outside of the first thermal insulating cover. The transportation device is configured for taking one or more containers stored in the storage system and delivering the containers to a selected destination.

[0023] Document US 2018/244469 A1 discloses an automatic locker device configured for a distribution of goods, including at least one storage area for the storage of loads including or formed by the goods, at least one retrieval point for the retrieval of the goods, and a handling device. The retrieval point includes a box having faces that are closed except for one open lateral face, having a first aperture oriented towards the exterior of the device, and an open lower face having a second aperture. The handling device is configured to shift one of the loads from the storage area towards the retrieval point and the vertically shift the load towards or through the second aperture of the open lower face, up to a height making it possible, through the first aperture of the open lateral face, to make available at least one of the goods included in or forming said load.

[0024] There is therefore a need to perfect an apparatus for distributing articles which can overcome at least one of the disadvantages of the state of the art.

[0025] In particular, one purpose of the present invention is to provide a reliable and economical apparatus for distributing articles which is able to store and deliver the articles selected and ordered by a user, by means of a web platform or by telephone, in a completely automatic manner.

[0026] Within the scope of this purpose, another aim of the invention is to provide an apparatus for distributing articles which is able to deliver to the user most of the articles managed by large-scale retail channels, above all foodstuffs and basic necessities, but not only.

[0027] Another purpose of the present invention is to provide an apparatus for distributing articles in which withdrawal takes place following a payment made according to any method provided for e-commerce (for example, prepaid account, credit card, payment on delivery).

[0028] Another purpose of the present invention is to provide an apparatus for distributing articles which guarantees safety against acts of vandalism and theft.

[0029] Furthermore, one purpose of the present invention is to provide an apparatus for distributing articles which is modular and assemblable, so as to adapt to any location in a public or private space.

[0030] Finally, one purpose of the present invention is to provide an apparatus for distributing articles that functions continuously, guaranteeing the user an uninterrupted service, even in the event of a suspension of the elec-

tricity supply.

[0031] The Applicant has devised, tested and embodied the present invention to overcome the shortcomings of the state of the art and to obtain these and other purposes and advantages.

SUMMARY OF THE INVENTION

[0032] The present invention is set forth and characterized in the independent claim. The dependent claims describe other characteristics of the present invention or variants to the main inventive idea.

[0033] In accordance with the above purposes, an apparatus for distributing articles according to the present invention comprises:

- a closed structure defining an area for containing the containers,
- a unit for moving the containers,
- at least one storage/withdrawal unit,
- a refrigeration unit,
- an access door made in at least one wall of the closed structure, wherein the activation at least of the opening of the access door occurs by means of recognition of an authorized operator/user through a user interface,

wherein the storage/withdrawal unit comprises shelves, defining a plurality of housings for the containers;

wherein the refrigeration unit is configured to refrigerate at least a part of the at least one storage/withdrawal unit, defining a non-refrigerated zone and/or at least one differentiated refrigeration zone;

wherein the movement unit comprises first upper movement means, second lower movement means, a rack and an element for translating the containers; wherein a first motor member is associated with the rack in order to position it in correspondence with a selected one of the housings;

wherein the access door and the rack are configured to store/withdraw the containers keeping the housings of the containers completely isolated from the external environment.

[0034] According to one aspect of the invention, the apparatus comprises an external control unit.

[0035] Advantageously, the external control unit is configured to:

- recognize, by means of a user interface, the master user (the operator who works on behalf of the manager, for example, a courier or employee of the large-scale distribution channel) and the user who has placed an order;
- automatically manage the regulation of temperature, humidity and lighting inside the apparatus;
- control the internal and external lighting of the appa-

- ratus;
- control the opening and closing of the single access door providing access to the apparatus in order to store/withdraw containers containing articles;
- automatically manage the selection of the free housings in the storage/withdrawal unit to store the containers;
- automatically manage and control the unit for moving the containers containing the articles ordered by the user, in the storage and withdrawal steps;
- control the external electrical power supply unit, the photovoltaic power supply unit and the solar energy storage unit;
- identify and report possible alarms against acts of vandalism and theft or malfunctions.

[0036] An apparatus for distributing articles is thus obtained which overcomes the limits of the state of the art and eliminates the defects present therein.

[0037] In this way, the risk of articles being stolen is practically eliminated and the functioning of the apparatus is continuous, guaranteeing a continuous service to the user.

BRIEF DESCRIPTION OF THE DRAWINGS

[0038] These and other aspects, characteristics and advantages of the present invention will become apparent from the following description of some embodiments, given as a non-restrictive example with reference to the attached drawings wherein:

- figs. 1a and 1b are two perspective views of an apparatus for distributing articles, according to some embodiments described here, in which fig. 1b is shown in partial section;
- fig. 2 is a perspective view of the inside of the apparatus for distributing articles, in which, for ease of understanding, the storage/withdrawal unit is disposed on one side only;
- fig. 3 is a perspective view of a unit for moving the containers belonging to the apparatus for distributing articles as above;
- fig. 4 is a perspective view of the rack belonging to the movement unit;
- fig. 5 is a perspective view of the support element that supports the rack, belonging to the movement unit;
- figs. 6a is a perspective view in which a translation element, belonging to the movement unit, is mounted on the structure of the rack;
- fig. 6b is an enlarged perspective view of the translation element of fig. 6a;
- figs. 7a and 7b are two perspective views of the rack with a mounted protection, shown in the two positions it assumes during the storage/withdrawal steps of the containers;
- fig. 8a is a perspective view of the storage/withdrawal

unit belonging to the apparatus for distributing articles;

- fig. 8b is a perspective view of the rack in the operating step of storage/withdrawal in correspondence with a free housing;
- fig. 9a is a perspective view of the inside of the apparatus for distributing articles in the inactive position;
- fig. 9b is a front view of the movement unit of fig. 9a, in the upper extreme position, highlighting the movements relating to the operating step of storing a container;
- figs. 10a, 10b, 10c, 10d and 10e show, in a detailed perspective view, the movement unit, in accordance with the present invention, in different operating steps.

[0039] To facilitate comprehension, the same reference numbers have been used, where possible, to identify identical common elements in the drawings. It is understood that elements and characteristics of one embodiment can conveniently be incorporated into other embodiments without further clarifications.

25 DETAILED DESCRIPTION OF SOME EMBODIMENTS

[0040] We will now refer in detail to the possible embodiments of the invention, of which one or more examples are shown in the attached drawings, by way of a non-limiting example. The phraseology and terminology used here is also for the purposes of providing non-limiting examples.

[0041] The attached drawings are used to describe some embodiments of an apparatus for distributing articles, indicated with reference number 100. These articles are contained inside containers 101.

[0042] By article, here and hereafter in the description, we mean any consumer good managed by a large-scale retail channel and, preferably, foodstuffs and/or essential goods; however, this is not to be interpreted in a limiting manner.

[0043] By container 101, here and hereafter in the description, we mean any casing whatsoever, having the shape of a parallelepiped or cylindrical or prismatic symmetry or suchlike, inside which the articles to be distributed are housed. The sizes of the container 101 are such as to contain a quantity of articles that is congruous, for example, with an average shop at a point of sale.

[0044] According to some embodiments, the container 101 can be made of materials such as cardboard, rigid plastic or suchlike. Furthermore, preferably, the container 101 contains inside it a sealed plastic bag, adhering to the internal walls of the container 101 itself, having the function of preventing the accidental percolation of liquids, in the event that the container 101 contains articles of a foodstuff type. Furthermore, preferably, the plastic bag as above is equipped with sub-pockets configured to divide the articles to be contained inside the container

101, separating them as a function of their product class (for example, foodstuffs, detergents, drugs, etc.). The container 101 is configured to be transported by hand by a user, for example, through the presence of suitable apertures on its walls. Finally, the container 101 can be used in disposable mode, be recycled or used several times.

[0045] The composition of the containers 101 is executed by the operators of the large-scale distribution channel and occurs directly at the existing points of sale or through a dedicated logistics platform, following the orders of the articles received from a user by means of a web-based platform or by telephone.

[0046] With reference to figs. 1a, 1b and 2, an apparatus 100 according to the present invention for distributing articles housed in containers 101 comprises a movement unit 102, at least one storage/withdrawal unit 103, a refrigeration unit 104 and an external control unit (not shown).

[0047] In accordance with a preferential embodiment, the movement unit 102 and the at least one storage/withdrawal unit 103 are configured to be disposed inside a closed structure 105. In particular, the storage/withdrawal unit 103 and the closed structure 105 are modular and assemblable. The movement unit 102 is, on the other hand, configured to interface with the inside and the outside of the closed structure 105.

[0048] By closed structure 105, here and hereafter in the description, we mean a box, a cabin or a compartment delimited at the upper part by a ceiling 105a, at the lower part by a floor 105b and at the perimeter by front 105c, lateral 105d and external rear walls 105e which form a closed polygon (preferably, a rectangle or a square), when viewed in plan. This closed structure 105 also comprises an aperture 105f, made in at least one wall of the closed structure 105, which can be opened by means of an access door 106. According to one preferred embodiment, the aperture 105f, associated with the access door 106, is disposed only in correspondence with the front wall 105c. This access door 106 (for example, of the shutter type, sliding door type or suchlike) can be opened and closed by an operator/user in order to access the unit 102 in order to move the containers 101 inside the closed structure 105. According to one preferred embodiment, the access door 106 can only be opened by authorized operators/users, by means of identification codes (for example, alphanumeric or QR) and/or by means of personal identification devices (for example, badges, smart cards, magnetic/electronic cards or suchlike). According to possible embodiments, the identification of the operator/user occurs by means of a user interface 107 (for example, alphanumeric keypad, scanner reader, magnetic/electronic card reader or suchlike) disposed on the side of the access door 106. In addition, according to another preferred embodiment, the distribution apparatus 100 also comprises a video surveillance unit (for example, closed-circuit video cameras), so as to monitor the inside and the outside of the closed structure 105. Advanta-

geously, the external control unit of the apparatus 100 monitors the accesses to the closed structure 105.

[0049] According to a possible preferred embodiment, the distribution apparatus 100, in addition to being powered directly by the external electric power grid, comprises, above the ceiling 105a, a cover 108, on which a photovoltaic power supply unit 108a is attached. Furthermore, the apparatus 100 comprises a solar energy storage unit (not shown), formed, for example, by lithium batteries or accumulators, which is disposed in a special housing made on the floor 105b of the apparatus 100.

[0050] In this way, advantageously, the energy requirements of the distribution apparatus 100 can be covered exclusively by the photovoltaic power supply unit 108a, given the low energy consumption of the apparatus 100 itself, even in the absence of the supply of electrical energy from the distribution grid.

[0051] The presence of the closed structure 105, advantageously, guarantees ideal conditions of temperature, humidity and lighting inside it for the temporary storage of the articles housed in the containers 101.

[0052] Advantageously, the external control unit of the apparatus 100 automatically manages and adjusts the temperature, humidity and lighting, through the implementation of appropriate software, once the desired values have been set by the operator of the large-scale distribution channel. According to one possible embodiment, any anomalies are reported to the operator of the large-scale distribution channel by means of a GSM interface.

[0053] The closed structure 105 of the apparatus 100 also comprises a first door 105g, which can be disassembled, disposed in correspondence with one of the lateral walls 105d and contiguous to the external rear wall 105e. By disassembling the first door 105g, the operator of the large-scale distribution channel accesses the inside of the distribution apparatus 100 for any maintenance operations, through the opening of a second door 105h, disposed on an internal rear wall 105m, which communicates with a central lane 109 of the apparatus 100.

[0054] According to a preferred variant, the ceiling 105a, the floor 105b and all the walls 105c, 105d, 105e, 105g, 105m are made by means of sandwich panels in painted or galvanized sheet metal with expanded polyurethane insulation.

[0055] The refrigeration unit 104 is configured to refrigerate at least a part of the at least one storage/withdrawal unit 103, defining a non-refrigerated zone and/or at least one differentiated refrigeration zone. The at least one differentiated refrigeration zone preserves perishable articles, such as, for example, fruit and vegetables, fish, frozen foods or suchlike.

[0056] According to one possible embodiment, the refrigeration unit 104 is located inside the closed structure 105, aligned with the central lane 109 and above the second door 105h.

[0057] In accordance with one possible embodiment,

the storage/withdrawal unit 103 of the apparatus 100 comprises shelves 103a, 103b, one specular with respect to the other, configured to define a plurality of housings 103c for the containers 101. These shelves 103a, 103b are attached (for example, by welding or bolted connection) to the lateral walls 105d of the closed structure 105, forming a number of rows "i" and a number of columns "n", which vary from apparatus to apparatus, according to requirements. According to some variants, the shelves 103a, 103b can be made of bent sheet metal (for example, painted, galvanized or stainless steel) or of molded plastic material or suchlike.

[0058] In the standard configuration, the apparatus 100 for distributing articles comprises two storage/withdrawal units 103 disposed inside a bearing unit 110 on the inside of both lateral walls 105d of the closed structure 105.

[0059] In the attached drawings, for clarity of representation, the storage/withdrawal unit 103 is shown on the left side only.

[0060] With reference to figs. 1b and 2, the bearing unit 110 comprises a pair of tracks 110a, in correspondence with the base and the top, which define a central lane 109. Furthermore, the bearing unit 110 is modular and assemblable, similarly to the storage/withdrawal unit 103 and to the closed structure 105.

[0061] According to possible embodiments, the bearing unit 110 is made by means of the stable union of metal section bars or circular hollow section bars made of painted steel, aluminum, stainless steel or suchlike.

[0062] The movement unit 102 comprises first upper movement means 102a, second lower movement means 102b, a traction member 102d, a counterweight 102e, a rack 111, a support element 112 of said rack 111, a translation element 113 of containers 101 and a protection element 114 of the aforementioned rack 111.

[0063] The upper 102a and lower movement means 102b are connected to each other, for example, by means of metal section bars or circular hollow section bars.

[0064] Furthermore, the traction member 102d is connected at one end to the rack 111 and at the opposite end to the counterweight 102e.

[0065] A first motor member is associated with the traction member 102d and, therefore, with the rack 111 in order to move the latter upward or downward (first movement U in fig. 9a).

[0066] The traction member 102d can comprise, for example, a chain, a transmission belt, a cable or other similar elements.

[0067] In fact, the rack 111 is configured to move, for example by means of bearings or wheels, between the two upper 102a and lower movement means 102b, in order to position itself in correspondence with a selected one of the housings 103c of the "ith" row of the storage/withdrawal unit 103 (first movement U of fig. 9a), in which to store or withdraw a container 101 of articles.

[0068] The upper 102a and lower movement means 102b are disposed parallel and in a specular manner with

respect to each other. Moreover, the upper 102a and lower movement means 102b are suitable to slide, for example, by means of wheels 102c, along the tracks 110a of the bearing unit 110. In particular, the profile of the wheels 102c couples in a specular manner with the corresponding profile of the tracks 110a. The presence of two overlapping upper 102a and lower movement means 102b prevents the possible overturning of the movement unit 102 during its movement.

[0069] The movement unit 102, therefore, moves forward and backward along the central lane 109, in order to position itself in correspondence with one housing 103c of the nth column of the storage/withdrawal unit 103 (second movement V of fig. 9a), in which to store or withdraw a container 101 of articles. To this end, a second motor member is associated with the movement unit 102 by means of, as a non-limiting example, a chain, a belt, a cable, a rack or suchlike.

[0070] In accordance with possible embodiments, the selection of the position of the storage/withdrawal unit 103 occurs through the presence of a position sensor 115, associated with the first lower movement means 102b, and of a striker bar 116.

[0071] According to one possible variant, the striker bar 116 is laterally attached to one of the tracks 110a, disposed at the base of the bearing unit 110.

[0072] The position sensor 115 is configured to read striker elements (for example, notches, engravings, reliefs or suchlike) present on the striker bar 116 in order to identify the positions of the storage/withdrawal unit 103, in correspondence with each nth column.

[0073] According to a preferential embodiment, the position sensor 115 is a magnetic/optical absolute linear encoder. This prevents the "homing" functionality in the event of an interruption of the electric power supply to the apparatus 100.

[0074] The support element 112 is configured to support the rack 111 and the translation element 113 of containers 101. Furthermore, said support element 112 comprises an actuator 112a, connected to the rack 111, which is configured to raise/lower (third movement W and fifth movement Y of figs. 9b, 10b and 10d) said rack 111 together with the translation element 113, at least during the step of storing/withdrawing the containers 101 from the housings 103c of the storage/withdrawal unit 103.

[0075] In accordance with possible solutions, the actuator 112a can be selected from a group comprising a hydraulic cylinder, a pneumatic cylinder, an electromechanical linear actuator or other similar or comparable elements.

[0076] According to a preferred variant, a third motor member is associated with the electromechanical actuator 112a.

[0077] The rack 111 comprises a lower transverse guide element 111a, upper longitudinal guide elements 111b and a rear wall 111c.

[0078] The lower transverse guide element 111a is configured to support and guide the translation element

113.

[0079] The protection element 114 is configured to slide along the upper longitudinal guide elements 111b.

[0080] According to a preferred embodiment, the upper longitudinal guide elements 111b consist of fully extractable ball guides.

[0081] The translation element 113 comprises a series of wheels 113a configured to slide along the lower transverse guide element 111a of the rack 111. A fourth motor member is associated with the translation element 113, in order to move it transversely, toward the right or the left, with respect to the central lane 109 (fourth movement X and sixth movement Z of figs. 9b, 10c and 10e).

[0082] The rack 111, during the inactive step of the apparatus 100, finds itself perfectly aligned with the aperture 105f and, therefore, with the access door 106, and in contact with the front wall 105c of the closed structure 105.

[0083] The access door 106 and the rack 111 are configured to store/withdraw the containers 101 maintaining the housings 103c of such containers 101 completely isolated with respect to the external environment.

[0084] In particular, during the inactive step as above, the protection element 114 is in a first position of engagement, or closure, with respect to the rack 111 (fig. 7a). In this way, also thanks to the presence of the rear wall 111c, the protection element 114 isolates the external environment from the internal environment of the closed structure 105, minimizing heat loss and guaranteeing safety against vandalism and theft.

[0085] The protection element 114 moves into a second position of disengagement, or opening, with respect to the rack 111, during the operating step of storage/withdrawal, in which the movement unit 102 moves (fig. 7b), leaving free the transverse passage of the container 101 (movements X and Z of figs. 9b, 10c and 10e).

[0086] The protection element 114 automatically moves from the first position of engagement, or closure, to the second position of disengagement, or opening, by connection with the rack 111 through an elastic return element, such as, for example, a spring, or through a counterweight.

[0087] With reference to figs. 9a, 9b 10a, 10b, 10c, 10d and 10e, we will now describe the functioning of the apparatus 100 for distributing articles, when it is necessary to store a container 101 inside the apparatus 100.

[0088] With reference to fig. 9a, in the step of introducing a new container 101 containing articles into the apparatus 100, the rack 111 of the movement unit 102 is located in correspondence with the aperture 105f of the closed structure 105, in the inactive position.

[0089] Following the identification of the operator of the large-scale distribution channel by means of the user interface 107, the external control system recognizes the free housings 103c and assigns one of them to the new container 101 to be stored, ordered by a user.

[0090] At this point, the access door 106 opens giving access to the rack 111 of the movement unit 102.

[0091] Once the operator has inserted and positioned the container 101 inside the rack 111, the access door 106 closes.

[0092] Subsequently, with reference again to fig. 9a, the rack 111, following the first movement U, is moved in correspondence with the row corresponding to the free housing 103c, assigned to the new container 101. The movement unit 102 is then moved, following the second movement V, in correspondence with the column corresponding to the free housing 103c assigned (fig. 10a).

[0093] Now, with reference to figs. 9b and 10b, the rack 111 is raised (third movement W).

[0094] This allows the subsequent fourth transverse movement X of the container 101, by means of the translation element 113, until such container 101 is completely inside the housing 103c assigned (fig. 10c).

[0095] Subsequently, the rack 111 is lowered (fifth movement Y), letting the container 101 rest on the shelves 103a, 103b.

[0096] At this point, the translation element 113 returns to the central position of the rack 111, in correspondence with the central lane 109 (sixth movement Z).

[0097] Finally, the movement unit 102, together with the rack 111, through the movements V and U return to the initial inactive position.

[0098] According to a preferred embodiment, the apparatus 100 for distributing articles according to the present invention is configured in such a way as to be transported by road train along motorways and ordinary roads.

[0099] Conversely, as regards the withdrawal of a container 101 containing articles ordered by a user, the functioning of the distribution apparatus 100 occurs, in summary, through the following points:

- user identification by means of the user interface 107;
- identification of the housing 103c in which the container 101 containing the articles ordered is stored;
- first movement U;
- second movement V;
- movement Z, in the opposite sense to that shown in figs. 9b and 10e;
- movement Y, in the opposite sense to that shown in figs. 9b and 10d;
- movement X, in the opposite sense to that shown in figs. 9b and 10c;
- movement W, in the opposite sense to that shown in figs. 9b and 10b;
- return of the movement unit 102 together with the rack 111 to the initial inactive position, through movements V and U;
- opening of the access door 106;
- withdrawal of the container 101 by the user;
- closing of the access door 106.

[0100] Advantageously, the external control unit of the apparatus 100 for distributing articles is configured to:

- recognize, by means of the user interface 107, an authorized operator of the large-scale distribution channel and an authorized user who has placed an order;
- automatically manage the regulation of temperature, humidity and lighting inside the apparatus 100;
- control the external and internal lighting of the apparatus 100;
- control the opening and closing of the access door 106 to the apparatus 100 to store/withdraw containers 101 containing articles;
- automatically manage the selection of the free housings 103c in the storage/withdrawal unit 103 to store the containers 101;
- automatically manage and control all the movements of the unit 102 for moving the containers 101, in the storage and withdrawal steps;
- control the external electric power supply unit, the photovoltaic power supply unit 108a and the solar energy storage unit;
- identify and report possible alarms against acts of vandalism and theft or malfunctions.

[0101] It is clear that modifications and/or additions of parts may be made to the apparatus 100 for distributing articles as described heretofore, without departing from the field and scope of the present invention, as defined by the claims.

[0102] In the following claims, the sole purpose of the references in brackets is to facilitate reading: they must not be considered as restrictive factors with regard to the field of protection claimed in the specific claims.

Claims

1. Apparatus (100) for distributing articles contained in containers (101), comprising:

- a closed structure (105) defining an area for containing the containers (101) and delimited at the upper part by a ceiling (105a), at the lower part by a floor (105b) and at the perimeter by front (105c), lateral (105d) and external rear walls (105e),
- a unit (102) for moving the containers (101),
- at least one storage/withdrawal unit (103),
- a refrigeration unit (104),
- an access door (106) made in at least one wall of said closed structure (105), wherein the activation at least of the opening of said access door (106) occurs by means of recognition through a user interface (107) of an authorized operator/user,
- said closed structure (105) further comprising an aperture (105t), made in at least one wall of the closed structure (105), which can be opened by means of said access door (106),

wherein said storage/withdrawal unit (103) comprises shelves (103a, 103b), defining a plurality of housings (103c) for said containers (101); wherein said refrigeration unit (104) is configured to refrigerate at least a part of the at least one storage/withdrawal unit (103), defining a non-refrigerated zone and/or at least one differentiated refrigeration zone;

wherein said movement unit (102) comprises first upper movement means (102a), second lower movement means (102b), a rack (111) and a translation element (113) of containers (101), said rack (111) comprising a lower transverse guide element (111a) configured to support and guide the translation element (113) and a rear wall (111c);

wherein a first motor member is associated with said rack (111) in order to position it in correspondence with a selected one of said housings (103c);

wherein said access door (106) and said rack (111) are configured to store/withdraw the containers (101) keeping said housings (103c) of said containers (101) completely isolated from the external environment,

said apparatus (100) being **characterized in that** said rack (111) further comprises upper longitudinal guide elements (111b),

said apparatus (100) further comprising a protection element (114) of said rack (111) sliding along said upper longitudinal guide elements (111b),

wherein said protection element (114) has a first position of engagement, or closure, with respect to the rack (111) in order to isolate the external environment from the internal environment of the closed structure (105), and a second position of disengagement, or opening, with respect to the rack (111), in order to leave the transverse passage of the container (101) free, said protection element (114) automatically moving from said first position of engagement, or closure, to said second position of disengagement, or opening, by connection with the rack (111) by means of an elastic return element or by means of a counterweight,

wherein said rack (111), during an inactive step of the apparatus (100), is perfectly aligned with said aperture (105f) of the closed structure (105) and, therefore, with the access door (106), and in contact with the front wall (105c) of the closed structure (105),

wherein, during said inactive step, the protection element (114) is in said first position of engagement with respect to the rack (111) so that, also thanks to the presence of the rear wall (111c), the protection element (114) isolates the external environment from the internal environment

of the closed structure (105).

2. Apparatus as in claim 1, also comprising a bearing unit (110) provided with a pair of tracks (110a) in correspondence with the base and the top, wherein said first upper movement means (102a) and second lower movement means (102b) are suitable respectively to slide along said tracks (1 10a). 5
3. Apparatus as in claim 2, also comprising a position sensor (115) associated with the first lower movement means (102b) and a striker bar (116), wherein said position sensor (115) is configured to read striker elements present on the striker bar (116) to identify the positions of the storage/withdrawal unit (103). 10
4. Apparatus as in any claim hereinbefore, also comprising a support element (112) configured to support said rack (111) and said translation element (113) of containers (101), an actuator (112a) being present to raise/lower said rack (111) together with the translation element (113), at least during the step of storing/withdrawing the containers (101) from the housings (103c) of the storage/withdrawal unit (103). 20
5. Apparatus as in claims 2 or 3 or as in claim 4 when depending on claims 2 or 3, wherein the closed structure (105), the at least one storage/withdrawal unit (103) and the bearing unit (110) are modular and assemblable. 25
6. Apparatus as in any claim hereinbefore, further comprising an external control unit configured for at least one activity of either recognizing an authorized operator/user by means of a user interface (107); automatically managing the regulation of temperature, humidity and lighting inside the closed structure (105); controlling the internal and external lighting of said apparatus (100); controlling the opening and closing of the access door (106); automatically managing the selection of the free housings (103c) in the storage/withdrawal unit (103) to store the containers (101); automatically managing and controlling all the movements of the unit (102) for moving the containers (101); controlling an external electrical power supply unit, a photovoltaic power supply unit (108a) and a solar energy storage unit; identifying and reporting possible alarms against acts of vandalism and theft or malfunctions. 30

Patentansprüche

1. Vorrichtung (100) zum Verteilen von Gegenständen, die in Behältern (101) enthalten sind, umfassend: 35
 - eine geschlossene Struktur (105), die eine Fläche zum Enthalten der Behälter (101) definiert, 40

und die am oberen Teil von einer Decke (105a), am unteren Teil von einem Boden (105b) und am Umfang von vorderen (105c), seitlichen (105d) und äußeren Wänden (105e) begrenzt ist,

- eine Einheit (102) zum Bewegen der Behälter (101),
- zumindest eine Lagerungs-/Entnahmeeinheit (103),

- eine Kühlungseinheit (104),

- eine Zugangstür (106), die in zumindest einer Wand der genannten geschlossenen Struktur (105) ausgebildet ist, worin die Aktivierung zumindest des Öffnens der genannten Zugangstür (106) durch eine Erkennung über eine Benutzerschnittstelle (107) eines autorisierten Bedieners/Benutzers erfolgt,

wobei die genannte geschlossene Struktur (105) ferner eine Öffnung (105f) umfasst, die in zumindest einer Wand der geschlossenen Struktur (105) ausgebildet ist, die mittels der genannten Zugangstür (106) geöffnet werden kann,

worin die genannte Lagerungs-/Entnahmeeinheit (103) Regale (103a, 103b) umfasst, die eine Vielzahl von Aufnahmen (103c) für die genannten Behälter (101) definieren;

worin die genannte Kühlungseinheit (104) dafür ausgelegt ist, zumindest einen Teil der zumindest einen Lagerungs-/Entnahmeeinheit (103) zu kühlen, wodurch ein nichtgekühlter Bereich und/oder zumindest ein differenzierter Kühlungsbereich definiert werden;

worin die genannte Bewegungseinheit (102) erste obere Bewegungsmittel (102a), zweite untere Bewegungsmittel (102b), ein Gestell (111) und ein Verschiebungselement (113) für die Behälter (101) umfasst, wobei das genannte Gestell (111) ein unteres querlaufendes Führungselement (111a), das dafür ausgelegt ist, das Verschiebungselement (113) zu stützen und zu führen, und eine Rückwand (111c) umfasst;

worin ein erstes Motorelement dem genannten Gestell (111) zugeordnet ist, um es an einer ausgewählten von den genannten Aufnahmen (103c) zu positionieren;

worin die genannte Zugangstür (106) und das genannte Gestell (111) dafür ausgelegt sind, die Behälter (101) zu lagern/zu entnehmen, indem die genannten Aufnahmen (103c) der genannten Behälter (101) von der äußeren Umgebung vollständig isoliert gehalten werden,

wobei die genannte Vorrichtung (100) **dadurch gekennzeichnet ist, dass** das genannte Gestell (111) ferner obere längsverlaufende Führungselemente (111b) umfasst,

wobei die genannte Vorrichtung (100) ferner ein Schutzelement (114) des genannten Gestells

(111) umfasst, das entlang der genannten oberen längsverlaufenden Führungselemente (111b) gleitet,

worin das genannte Schutzelement (114) eine erste Eingriffs- oder Schließstellung im Hinblick auf das Gestell (111), um die äußere Umgebung von der inneren Umgebung der geschlossenen Struktur (105) zu isolieren, und eine zweite Auslösungs- oder Öffnungsstellung im Hinblick auf das Gestell (111), um den querverlaufenden Durchlauf des Behälters (101) frei zu lassen, aufweist, wobei das genannte Schutzelement (114) sich automatisch von der genannten ersten Eingriffs- oder Schließstellung zur genannten zweiten Auslösungs- oder Öffnungsstellung durch Verbindung mit dem Gestell (111) mittels eines elastischen Rückstellelementes oder mittels eines Gegengewichtes bewegt, worin das genannte Gestell (111), während eines inaktiven Schrittes der Vorrichtung (100), zur genannten Öffnung (105f) der geschlossenen Struktur (105) und, daher, zur Zugangstür (106) vollkommen ausgerichtet ist, und mit der vorderen Wand (105c) der geschlossenen Struktur (105) im Kontakt steht,

worin, während des genannten inaktiven Schrittes, das Schutzelement (114) sich in der genannten ersten Eingriffsstellung im Hinblick auf das Gestell (111) befindet, so dass, auch dank dem Vorhandensein der Rückwand (111c), das Schutzelement (114) die äußere Umgebung von der inneren Umgebung der geschlossenen Struktur (105) isoliert.

2. Vorrichtung nach Anspruch 1, umfassend auch eine tragende Einheit (110), die mit einem Paar Schienen (110a) an dem Grund und an dem Oberteil versehen ist, worin die genannten ersten oberen Bewegungsmittel (102a) und die genannten zweiten unteren Bewegungsmittel (102b) dazu geeignet sind, jeweils entlang der genannten Schienen (110a) zu gleiten.
3. Vorrichtung nach Anspruch 2, umfassend auch einen Positionssensor (115), der den ersten unteren Bewegungsmitteln (102b) zugeordnet ist, und eine Schlagstange (116) umfasst, worin der genannte Positionssensor (115) dafür ausgelegt ist, Schlaglemente, die an der Schlagstange (116) vorhanden sind, zu lesen, um die Stellungen der Lagerungs-/Entnahmeeinheit (103) zu identifizieren.
4. Vorrichtung nach einem der vorhergehenden Ansprüche, umfassend auch ein Stützelement (112), das dafür ausgelegt ist, das genannte Gestell (111) und das genannte Verschiebungselement (113) für die Behälter (101) zu stützen, wobei ein Stellglied (112a) vorhanden ist, um das genannte Gestell (111) zusammen mit dem Verschiebungselement (113),

zumindest während des Schrittes des Lagerns/Entnehmens der Behälter (101) aus den Aufnahmen (103c) der Lagerungs-/Entnahmeeinheit (103), anzuheben/abzusenken.

5. Vorrichtung nach den Ansprüchen 2 oder 3 oder nach Anspruch 4, soweit dieser von den Ansprüchen 2 oder 3 abhängig ist, worin die geschlossene Struktur (105), die zumindest eine Lagerungs-/Entnahmeeinheit (103) und die tragende Einheit (110) modular und zusammenstellbar sind.
6. Vorrichtung nach einem der vorhergehenden Ansprüche, ferner umfassend eine äußere Steuerungseinheit, die für zumindest eine Aktivität von den folgenden ausgelegt ist: Erkennen eines autorisierten Bedieners/Benutzers über eine Benutzerschnittstelle (107); automatisches Verwalten der Einstellung der Temperatur, Feuchtigkeit und Beleuchtung innerhalb der geschlossenen Struktur (105); Steuern der inneren und der äußeren Beleuchtung der genannten Vorrichtung (100); Steuern des Öffnens und des Schließens der Zugangstür (106); automatisches Verwalten des Auswählens der freien Aufnahmen (103c) in der Lagerungs-/Entnahmeeinheit (103), um die Behälter (101) zu lagern; automatisches Verwalten und Steuern aller Bewegungen der Einheit (102) zum Bewegen der Behälter (101); Steuern einer äußeren elektrischen Stromversorgungseinheit, einer photovoltaischen Stromversorgungseinheit (108a) und einer Solarenergiespeicherungseinheit; Identifizieren und Berichten von möglichen Alarmen gegen Vandalenakte und Diebstahl oder Störungen.

Revendications

1. Appareil (100) pour distribuer des articles contenus dans des récipients (101), comprenant :
 - une structure fermée (105) définissant une zone de confinement des récipients (101) et délimitée à la partie supérieure par un plafond (105a), à la partie inférieure par un plancher (105b) et au périmètre par des parois avant (105c), latérales (105d) et arrière extérieures (105e),
 - une unité (102) pour déplacer les récipients (101),
 - au moins une unité de stockage/retrait (103),
 - une unité de réfrigération (104),
 - une porte d'accès (106) réalisée dans au moins une paroi de ladite structure fermée (105), dans laquelle l'activation au moins de l'ouverture de ladite porte d'accès (106) se fait au moyen d'une reconnaissance par une interface utilisateur (107) d'un opérateur/utilisateur autorisé,

ladite structure fermée (105) comprenant en outre une ouverture (105f), réalisée dans au moins une paroi de la structure fermée (105), qui peut être ouverte au moyen de ladite porte d'accès (106),

dans lequel ladite unité de stockage/retrait (103) comprend des étagères (103a, 103b), définissant une pluralité de logements (103c) pour lesdits récipients (101) ;

dans lequel ladite unité de réfrigération (104) est configurée pour réfrigérer au moins une partie de l'au moins une unité de stockage/retrait (103), définissant une zone non réfrigérée et/ou au moins une zone de réfrigération différenciée ; dans lequel ladite unité de mouvement (102) comprend des premiers moyens de mouvement supérieurs (102a), des seconds moyens de mouvement inférieurs (102b), une crémaillère (111) et un élément de translation (113) de récipients (101), ladite crémaillère (111) comprenant un élément de guidage transversal inférieur (111a) configuré pour supporter et guider l'élément de translation (113) et une paroi arrière (111c) ;

dans lequel un premier élément de moteur est associé à ladite crémaillère (111) afin de la positionner en correspondance avec l'un sélectionné desdits logements (103c) ;

dans lequel ladite porte d'accès (106) et ladite crémaillère (111) sont configurées pour stocker/retraiter les récipients (101) en maintenant lesdits logements (103c) desdits récipients (101) complètement isolés de l'environnement extérieur,

ledit appareil (100) étant **caractérisé en ce que** ladite crémaillère (111) comprend en outre des éléments de guidage longitudinaux supérieurs (111b),

ledit appareil (100) comprenant en outre un élément de protection (114) de ladite crémaillère (111) coulissant le long desdits éléments de guidage longitudinaux supérieurs (111b),

dans lequel ledit élément de protection (114) a une première position d'engagement, ou de fermeture, par rapport à la crémaillère (111) afin d'isoler l'environnement externe de l'environnement interne de la structure fermée (105), et une seconde position de dégagement, ou d'ouverture, par rapport à la crémaillère (111), afin de laisser le passage transversal du récipient (101) libre, ledit élément de protection (114) se déplaçant automatiquement de ladite première position d'engagement, ou de fermeture, à ladite seconde position de dégagement, ou d'ouverture, par connexion avec la crémaillère (111) au moyen d'un élément de rappel élastique ou au moyen d'un contrepoids,

dans lequel ladite crémaillère (111), pendant

une étape inactive de l'appareil (100), est parfaitement alignée avec ladite ouverture (105f) de la structure fermée (105) et, par conséquent, avec la porte d'accès (106), et en contact avec la paroi avant (105c) de la structure fermée (105),

dans lequel, pendant ladite étape inactive, l'élément de protection (114) est dans ladite première position d'engagement par rapport à la crémaillère (111) de sorte que, également grâce à la présence de la paroi arrière (111c), l'élément de protection (114) isole l'environnement externe de l'environnement interne de la structure fermée (105).

2. Appareil selon la revendication 1, comprenant également une unité de palier (110) pourvue d'une paire de pistes (110a) en correspondance avec la base et la partie supérieure, dans lequel lesdits premiers moyens de mouvement supérieurs (102a) et lesdits seconds moyens de mouvement inférieurs (102b) sont appropriés respectivement pour coulisser le long desdites pistes (110a).
3. Appareil selon la revendication 2, comprenant également un capteur de position (115) associé au premier moyen de mouvement inférieur (102b) et une barre de gâche (116), dans lequel ledit capteur de position (115) est configuré pour lire les éléments de gâche présents sur la barre de gâche (116) pour identifier les positions de l'unité de stockage/retrait (103).
4. Appareil selon l'une quelconque des revendications précédentes, comprenant également un élément de support (112) configuré pour supporter ladite crémaillère (111) et ledit élément de translation (113) de récipients (101), un actionneur (112a) étant présent pour soulever/abaisser ladite crémaillère (111) avec l'élément de translation (113), au moins pendant l'étape de stockage/retrait des récipients (101) des logements (103c) de l'unité de stockage/retrait (103).
5. Appareil selon les revendications 2 ou 3 ou selon la revendication 4 lorsqu'elle dépend des revendications 2 ou 3, dans lequel la structure fermée (105), l'au moins une unité de stockage/retrait (103) et l'unité de palier (110) sont modulaires et assemblables.
6. Appareil selon l'une quelconque des revendications précédentes, comprenant en outre une unité de commande externe configurée pour au moins une activité de reconnaissance d'un opérateur/utilisateur autorisé au moyen d'une interface utilisateur (107) ; gestion automatique de la régulation de la température, de l'humidité et de l'éclairage à l'intérieur de la structure fermée (105) ; commande de l'éclairage in-

terne et externe dudit appareil (100) ; commande de l'ouverture et de la fermeture de la porte d'accès (106) ; gestion automatique de la sélection des logements libres (103c) dans l'unité de stockage/retrait (103) pour stocker les récipients (101) ; gestion et commande automatiques de tous les mouvements de l'unité (102) pour déplacer les récipients (101) ; commande d'une unité d'alimentation électrique externe, d'une unité d'alimentation photovoltaïque (108a) et d'une unité de stockage d'énergie solaire ; identification et signalement d'alarmes possibles contre des actes de vandalisme et de vol ou de dysfonctionnements.

5

10

15

20

25

30

35

40

45

50

55

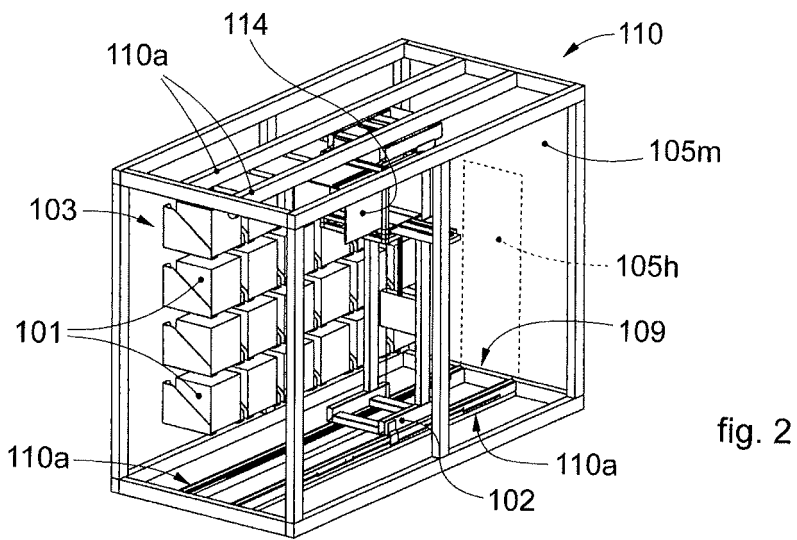
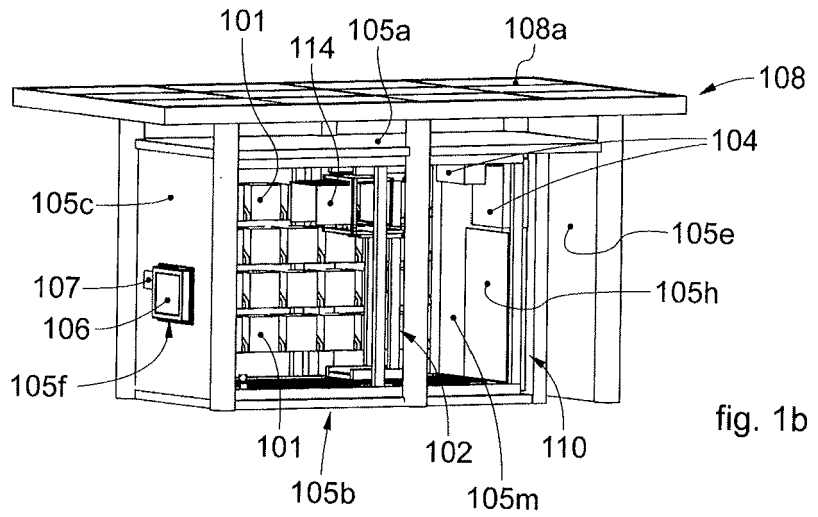
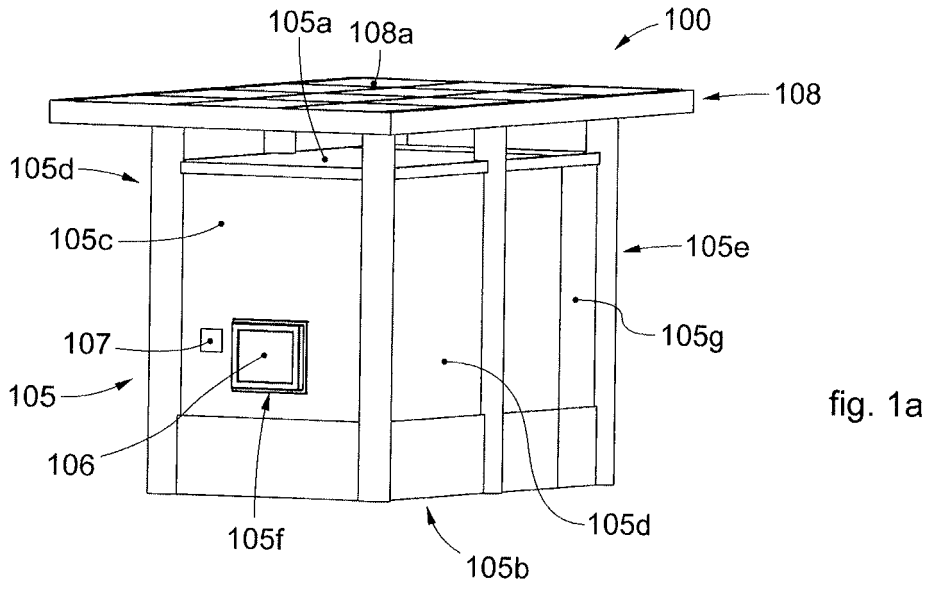

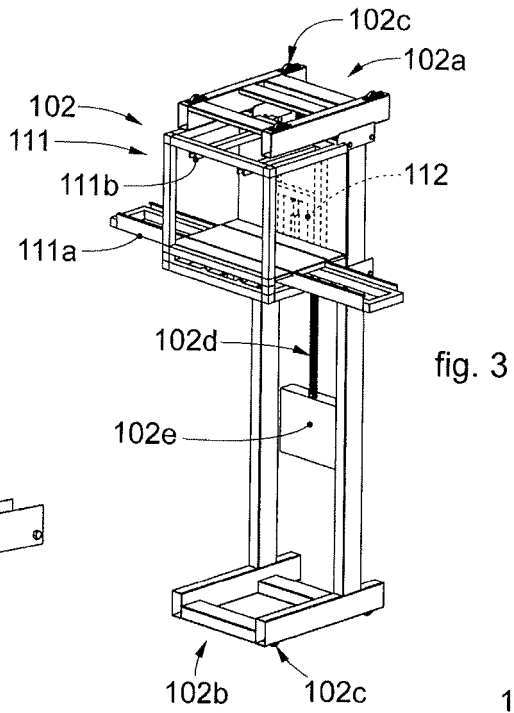

fig. 3

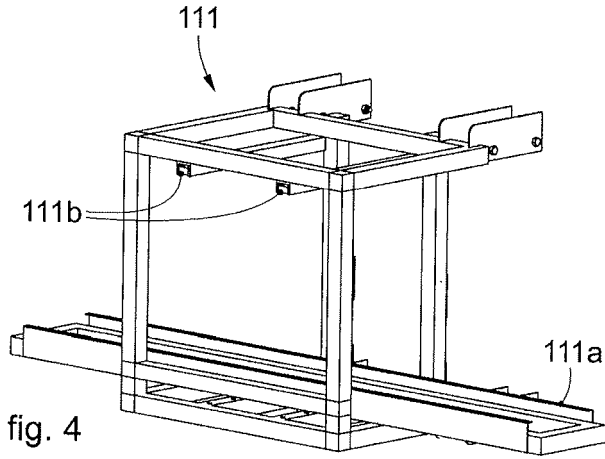

fig. 4

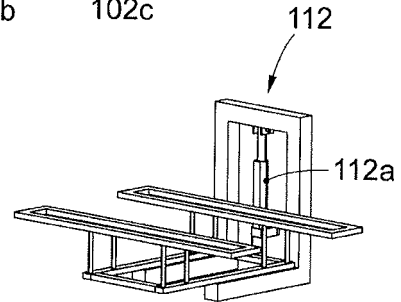

fig. 5

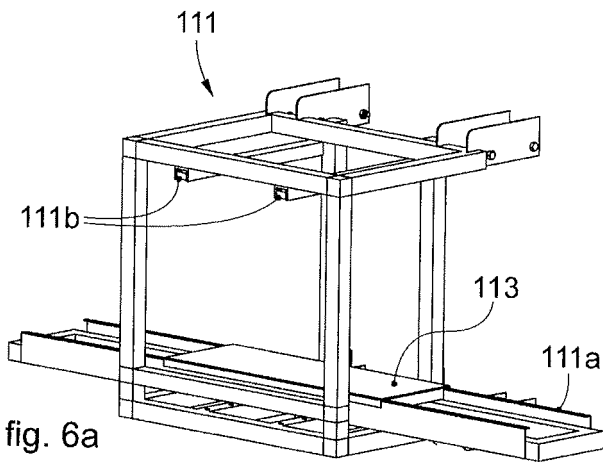

fig. 6a

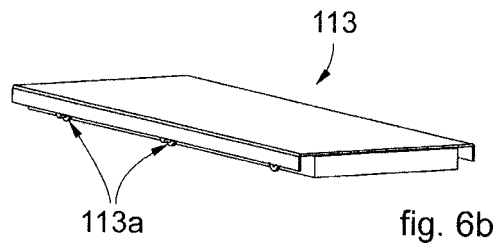

fig. 6b

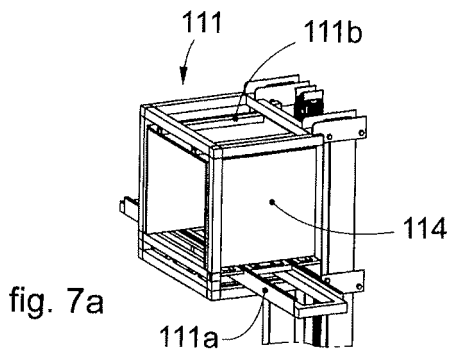

fig. 7a

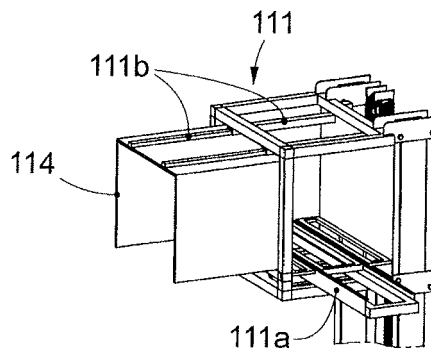

fig. 7b

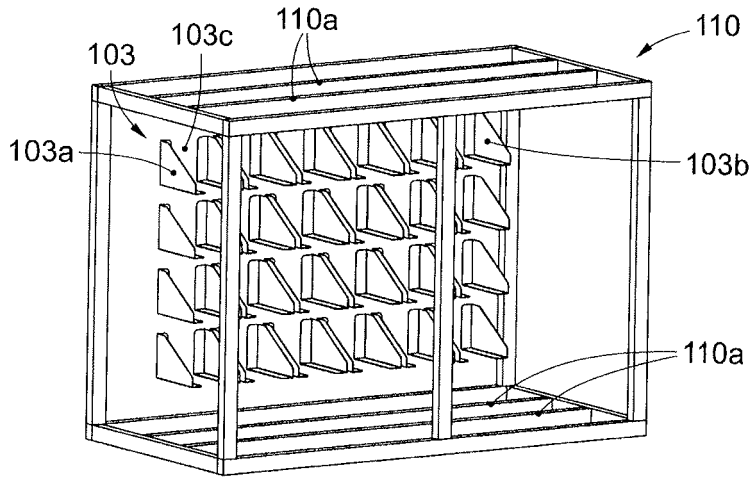

fig. 8a

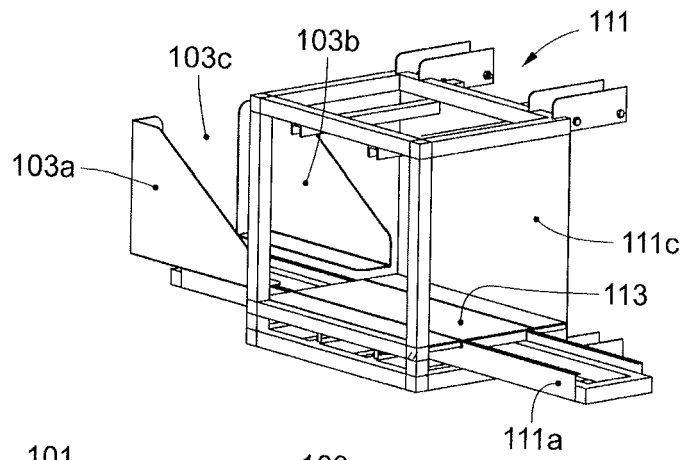

fig. 8b

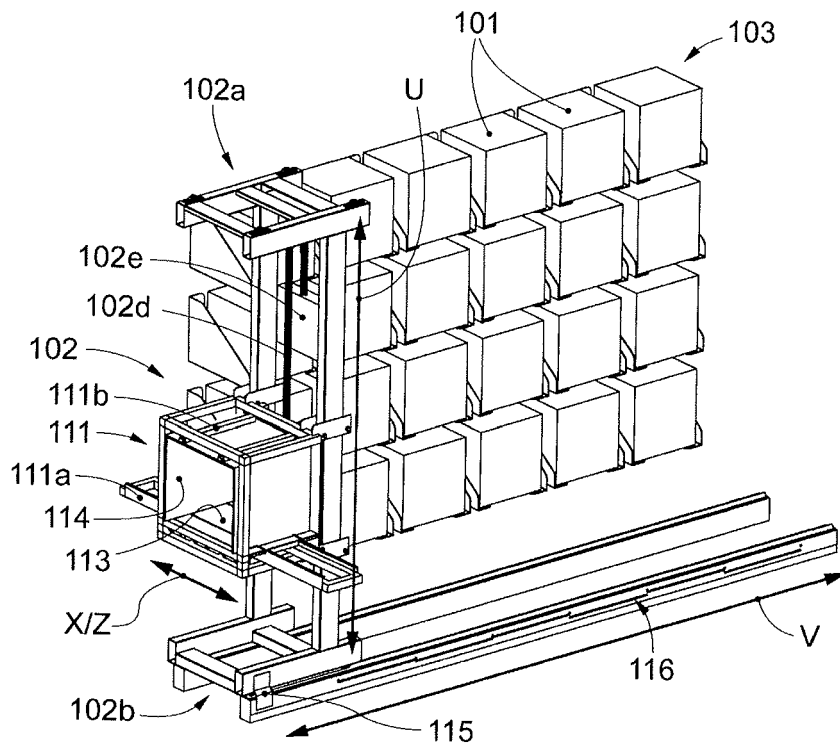

fig. 9a

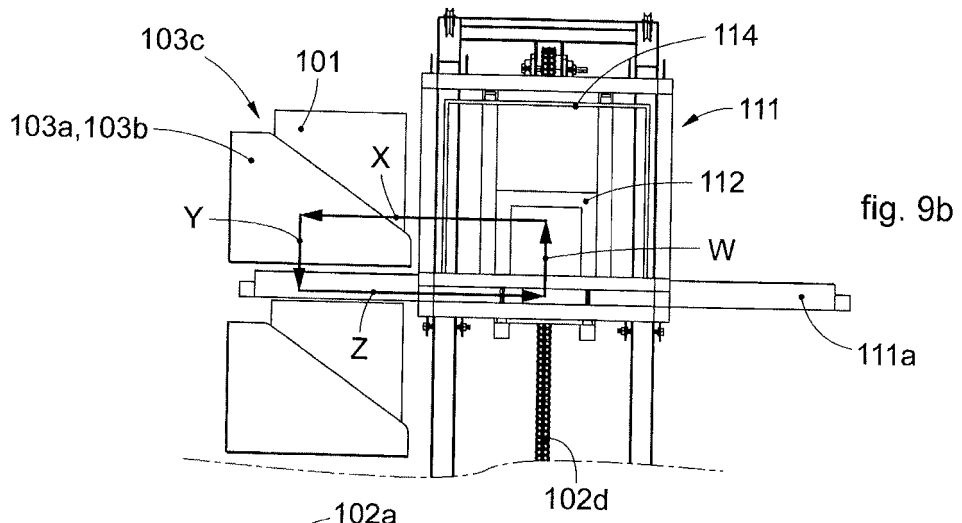

fig. 9b

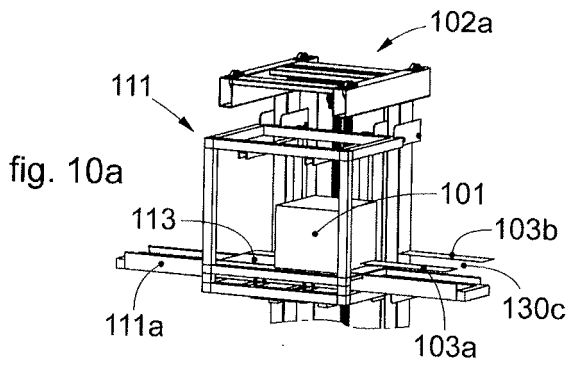

fig. 10a

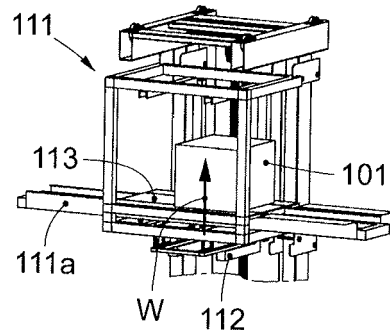

fig. 10b

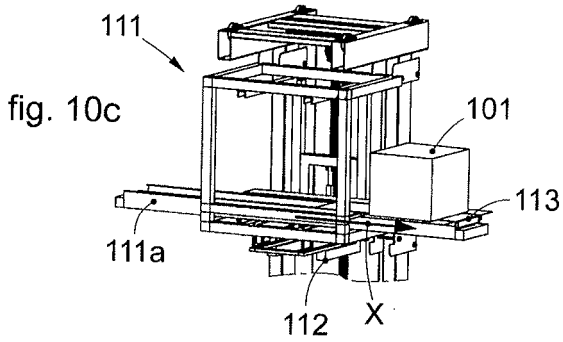

fig. 10c

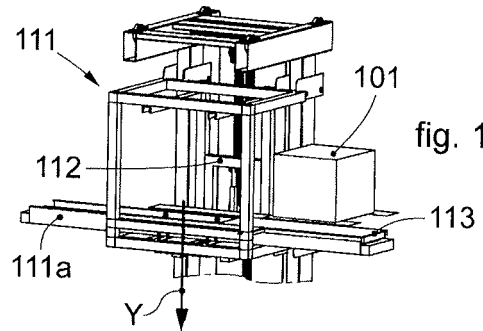

fig. 10d

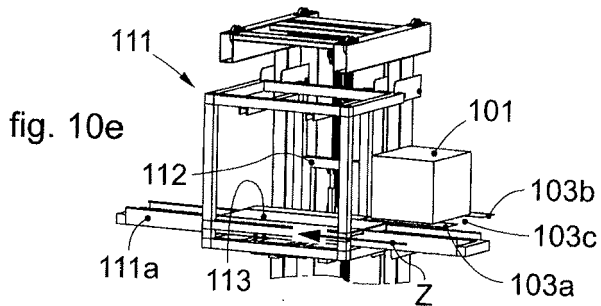

fig. 10e

REFERENCES CITED IN THE DESCRIPTION

This list of references cited by the applicant is for the reader's convenience only. It does not form part of the European patent document. Even though great care has been taken in compiling the references, errors or omissions cannot be excluded and the EPO disclaims all liability in this regard.

Patent documents cited in the description

- US 2015291357 A1 [0022]
- US 2018244469 A1 [0023]