

(19)



(11)

EP 4 151 333 B1

(12)

EUROPEAN PATENT SPECIFICATION

(45) Date of publication and mention of the grant of the patent:
24.07.2024 Bulletin 2024/30

(51) International Patent Classification (IPC):
B21F 3/04 ^(2006.01) **B21F 11/00** ^(2006.01)
B21F 23/00 ^(2006.01) **B21F 35/00** ^(2006.01)

(21) Application number: **21197470.4**

(52) Cooperative Patent Classification (CPC):
B21F 11/005; B21F 3/04; B21F 23/00; B21F 35/00

(22) Date of filing: **17.09.2021**

(54) COIL SPRING PRODUCTION WITH ROTARY CUTTER

HERSTELLUNG VON SCHRAUBENFEDERN MIT EINEM ROTATIONSSCHNEIDER
 PRODUCTION D'UN RESSORT HÉLICOÏDAL À L'AIDE D'UNE FRAISE ROTATIVE

(84) Designated Contracting States:
AL AT BE BG CH CY CZ DE DK EE ES FI FR GB GR HR HU IE IS IT LI LT LU LV MC MK MT NL NO PL PT RO RS SE SI SK SM TR

(74) Representative: **Kraus & Lederer PartGmbH**
Thomas-Wimmer-Ring 15
80539 München (DE)

(43) Date of publication of application:
22.03.2023 Bulletin 2023/12

(56) References cited:
EP-B1- 3 059 025 **WO-A1-2020/138376**
DE-B3- 102012 204 513 **DE-C1- 4 040 659**
US-A- 2 869 640 **US-A- 4 986 103**
US-A1- 2019 168 287 **US-B2- 8 978 434**

(73) Proprietor: **Spühl GmbH**
9300 Wittenbach (CH)

(72) Inventor: **KELLER, Roland**
9500 Wil (CH)

EP 4 151 333 B1

Note: Within nine months of the publication of the mention of the grant of the European patent in the European Patent Bulletin, any person may give notice to the European Patent Office of opposition to that patent, in accordance with the Implementing Regulations. Notice of opposition shall not be deemed to have been filed until the opposition fee has been paid. (Art. 99(1) European Patent Convention).

Description

FIELD OF THE INVENTION

[0001] The present invention relates to a mechanism for producing coil springs and to a method of producing coil springs.

BACKGROUND OF THE INVENTION

[0002] Mattresses, sofas or other bedding or seating furniture may be provided with innerspring units formed of coil springs. Such coil springs may for example be combined in a wire framework or may be enclosed by fabric to form an assembly of pocket springs.

[0003] The coil springs are typically wound from steel wire, using automated coil winding machines. EP 3 059 025 A1 describes a spring forming device in which a heated steel wire is continuously fed to a coiling mechanism which deforms the wire to a coil. A cutting mechanism cuts the wire when a given number of coil windings is formed. This cutting is performed without stopping the feeding of the steel wire, using a cutting blade which moves downward towards the steel wire and in a horizontal direction, along with an axial direction of the wire. This movement is achieved by guiding the cutting blade in a reciprocating motion between a top dead center and a bottom dead center. However, such guided reciprocating motion of the cutting blade may require a rather complex structure of the cutting mechanism.

[0004] Accordingly, there is a need for techniques which allow for efficiently producing coil springs from continuously fed wire.

[0005] Techniques for cutting wire of coil springs according to the prior art are known from documents US 8 978 434 B2, US 2 869 640 A, US 4 986 103 A, DE 40 40 549 C1, EP 3 059 025 B1, DE 10 2012 204513 B3, US 2019/168287 A1, WO 2020/138376 A1.

[0006] Document US 8 978 434 B2 forms the basis for the preamble of claims 1 and 13.

BRIEF SUMMARY OF THE INVENTION

[0007] The present invention provides a mechanism according to claim 1, and a method according to claim 13. The dependent claims define further embodiments.

[0008] Accordingly, an embodiment of the invention provides a mechanism for producing coil springs. The mechanism comprises a winding stage for engaging with a wire and deforming the wire to coil windings as the wire moves through the winding stage. Further, the mechanism comprises a feed mechanism configured to feed the wire to the winding stage. Further, the mechanism comprises a rotary cutter. The rotary cutter is configured to cut the deformed wire into portions forming separate coil springs and a blade which is driven for rotation about a stationary rotation axis. Accordingly, cutting of the wire can be achieved without requiring an excessively com-

plex cutting mechanism.

[0009] According to an embodiment, the feed mechanism is configured to maintain a constant speed of feeding the wire while the rotary cutter cuts the deformed wire.

5 The coil springs can thus be formed in an efficient manner, without requiring stoppage or slowing of the feeding speed. However, it is noted that the feed mechanism could also be configured to operate in a single-step or intermittent manner.

10 **[0010]** According to an embodiment, the mechanism further comprises a mandrel for cooperating with the blade to cut the wire. The mandrel may be arranged centrally within the coil spring being formed and thus also act as a guide or support for the coil spring being formed.

15 A position of the mandrel relative to the rotation axis of the blade may be adjustable. In addition or as an alternative, a position of the rotary cutter relative to the winding stage may be adjustable. In this way, the mechanism may be adapted to different wire gauges and/or geometries of the wire being formed.

20 **[0011]** According to the invention, the blade comprises a protrusion configured to engage between two coil windings of the deformed wire and separate the two coil windings as the blade rotates. In this way, it can be efficiently ensured that the deformed wire is cut at a desired position, taking into account that at an end portion of the coil spring there may be coil windings in close vicinity.

25 **[0012]** According to an embodiment, wherein the blade is formed on a terminal surface of a shaft portion driven to rotate about the rotation axis. The blade can thus be formed in a simple and robust manner. A need for a complex drive mechanism can be avoided.

30 **[0013]** According to an embodiment, the winding stage comprises at least one bending tool, typically two or more bending tools. Such one or more bending tools engage the wire at positions set according to a geometry of the coil springs. The winding stage may then be configured to maintain engagement of the bending tools with the deformed wire while the rotary cutter cuts the deformed

35 wire. In this way, cutting of the wire may be performed while keeping the deformed wire in a well-defined position. The least one bending tool may be driven to move the wire to a position in which the rotary cutter cuts the deformed wire. For example, the at least one bending tool may be driven to move during the process of winding the wire, thereby conveying a desired geometry to the coil spring being produced. At the end of the winding process, the at least one bending tool may be driven to

40 move the deformed wire towards the rotary cutter, so that the wire can be cut at a well-defined position. This movement may at the same time assist in producing the coil spring with more densely arranged coils at its end.

45 **[0014]** According to an embodiment, the mechanism may further comprise a heating stage configured to heat the wire before feeding into the winding stage. Deformation of the wire may thus be assisted by heating. Due to the constant speed of feeding the wire to the winding stage, the heating of the wire can be controlled in a pre-

cise manner.

[0015] According to an embodiment, the mechanism may further comprise an output stage for transferring the coil springs from the mechanism. The output stage may comprise a guide element for guiding movement of the deformed wire in the winding stage and towards a transport mechanism. The guide element may for example have V-shaped surfaces for engaging on an outer periphery of the coil spring being formed, so that coil springs of various geometry can be guided in a reliable manner. The transport mechanism may comprises at least one magnetic carrier for engaging with the deformed wire and moving the coil spring from the winding stage. In such case, the output stage may be configured to cause engagement of the at least one magnetic carrier with the deformed wire before the deformed wire is cut by the rotary cutter to release the coil spring being produced. Accordingly, before the coil spring being produced is released by cutting the deformed wire, the coil spring being produced is already engaged with the magnetic carrier. In this way, transfer of the coil spring from the winding stage may be performed in a reliable manner. In some embodiments, the transport mechanism may comprise a two or more of such magnetic carriers, e.g., to engage with different portions of the coil spring.

[0016] According to a further embodiment of the invention, a method for producing coil springs is provided. The method is implemented by a mechanism according to any one of the above embodiments. The method comprises:

- feeding a wire to a winding stage;
- engaging the wire in the winding stage to deform the wire to coil windings as the wire moves through the winding stage; and
- by a blade rotating about a stationary rotation axis, cutting the deformed wire into portions forming separate coil springs.

[0017] In the method, a constant speed of feeding the wire to the winding stage may be maintained while cutting the deformed wire.

[0018] In some embodiments, the method may further comprise heating the wire before feeding the wire to the winding stage.

[0019] In some embodiments, the method may further comprise maintaining engagement of bending tools of the winding stage with the deformed wire while the rotary cutter cuts the deformed wire.

[0020] In some embodiments, the method may further comprise guiding movement of the deformed wire in the winding stage and towards a transport mechanism. The transport mechanism may comprises at least one magnetic carrier for engaging with the deformed wire and moving the coil spring from the winding stage. In such case, the method may comprise causing engagement of the at least one magnetic carrier with the deformed wire before the deformed wire is cut by the rotary cutter to

release the coil spring being produced.

BRIEF DESCRIPTION OF DRAWINGS

[0021] Embodiments of the invention will be described with reference to the accompanying drawings.

Figs. 1A, 1B, and 1C schematically illustrate a mechanism according to an embodiment of the invention.

Figs. 2 shows a perspective view for further illustrating elements of the mechanism.

Figs. 3A, 3B, and 3C illustrate a blade of a rotary cutter according to an embodiment of the invention.

Fig. 4 shows a flowchart for schematically illustrating a coil spring production method according to an embodiment of the invention.

DETAILED DESCRIPTION OF EMBODIMENTS

[0022] Exemplary embodiments of the invention as explained in the following relate to a mechanism for producing coil springs. The mechanism may for example be part of or be used in connection with an assembly machine for innerspring units. Such innerspring units may be based on coil springs connected in a wire framework or on coil springs enclosed by fabric to form an assembly of pocket springs.

[0023] Figs. 1A, 1B, 1C, and 2 schematically illustrate a mechanism 100 for producing coil springs 10. Fig. 1A, shows a plan view in an x-y plane, which may for example correspond to a vertical plane. Fig. 1B shows a further plan view in an x-y plane, which is offset from the illustration plane of Fig. 1A. Fig. 1C illustrates a plan view in an y-z plane, which is perpendicular to the illustration planes of Figs. 1A and 1B. Fig. 2 shows a perspective view of elements of the mechanism 100.

[0024] As illustrated, the mechanism 100 includes a winding stage 110, a feeding stage 120, a rotary cutter 130, a heating stage 140, and an output stage 150. The winding stage 110 deforms a wire 20, e.g., steel wire, to coil windings. For this purpose, the winding stage 110 is provided with bending tools 115. The bending tools 115 engage the wire 20 at positions which are set according to the desired geometry of coil springs 10 to be produced by the mechanism 100. The bending tools 115 may be motor-driven or be driven by some other kind of drive mechanism, e.g., by a cam drive, so that the positions of engaging the wire 20 can be controlled in an automated manner. As the wire 20 moves through the winding stage 110, the engagement with the bending tools 115 causes the wire 20 to be deformed to coil windings. The bending tools 115 may be set and controlled according to a desired curvature of the coil windings and/or according to a desired pitch of the coil windings. Various types of bending tools may be used, e.g., a bending tool in which the

wire is engaged between pins or a bending tool in which the wire is engaged in a groove or other type of recess formed on a tip of the bending tool. Further, it is noted that while in the illustrated example the mechanism is illustrated as being provided with two bending tools 115, other numbers of bending tools 115 could be used as well. For example, a higher number of bending tools 115 could be used to produce coil springs 10 of more complex geometry.

[0025] As further illustrated, the mechanism 100 is provided with a feeding stage 120. The feeding stage 120 feeds the wire 20 to the winding stage 110. In the illustrated example, the feeding stage 120 is assumed to be provided with two pairs of driven rollers 125. However, it is noted that utilization of only one pair of driven rollers 125 or utilization of more than two pairs of driven rollers 125 would be possible as well. The wire 20 is engaged between the two rollers 125 of each pair, so that rotation of the rollers 125 pushes the wire 20 into the winding stage 110. A guide element 126 is provided at an interface of the feeding stage 120 to the winding stage 110, so that the winding stage 110 receives the wire 20 in a well-defined position. The feeding stage 120 feeds the wire 20 at constant speed to the winding stage 110, so that the wire 20 is pushed through the winding stage 110, where it is engaged by the bending tools 115 and thus deformed to the coil windings.

[0026] Further, the mechanism 100 is provided with a rotary cutter 130. The rotary cutter 130 is arranged in the vicinity of the winding stage 110 so that the rotary cutter 130 can cut the wire 20 deformed in the winding stage 110. As further explained below, the rotary cutter 130 is based on a blade 135 which is fixedly mounted on a rotary shaft 136 rotates about a stationary rotation axis 135X. This rotation axis 135X is substantially parallel to the axis of the coil springs 10 being produced, which in the illustrated example corresponds to the z-axis. The rotating blade 135 cooperates with a mandrel 137. As for example illustrated in Fig. 1C, the deformed wire 20 passes between the mandrel 137 and the rotating cutting blade 135. Due to rotation of the blade 135, the deformed wire 20 as at a given point compressed between the mandrel 137 and a cutting edge 139 of the blade 135, so that the cutting edge 139 cuts into the deformed wire 20 and a portion of the deformed wire 20 corresponding to a coil spring 10 is sheared off. The rotary cutter 130 may cut the deformed wire 20 while maintaining the constant speed of feeding the wire 20 to the winding stage 110. Further, engagement of the deformed wire 20 with at least one of the bending tools 115 is maintained while the rotary cutter 130 cuts the deformed wire 20.

[0027] As mentioned above, one or more of the bending tools 115 may be motor-driven. In this way, the spatial position at which the bending tool 115 engages the wire 20 can be changed during the winding process to thereby obtain a desired geometry of the coil spring 10 being produced. Further, the bending tool 115 can be driven towards the rotary cutter 130, so that the rotary cutter

130 can cut the wire 20 at a desired position. As can for example be seen from Figs. 1A and 1C, the rotating blade 135 of the rotary cutter 130 may rotate about an axis extending in the z-direction, so that the cutting edge 139 moves along a circular trajectory in the x-y-plane. During winding of the coil spring 10, the bending tool 115 which is closest to the rotary cutter 130 may move along the z-direction, e.g., to vary the pitch of the coil windings. In some cases, the bending tool 115 may also move within the x-y-plane, e.g., to vary the diameter of the coil windings. At the end of the winding process, the bending tool 115 may move the wire 20 towards the rotary cutter 130, so that it intersects with the trajectory of the cutting edge 139. In this way, the wire 20 can be cut at a well-defined position. Further, the movement of the bending tool 115 may help to produce more densely arranged coil windings at the end of the coil spring 10.

[0028] The speed of rotation of the blade 135 may be set in accordance with the constant speed of feeding the wire 20 to the winding stage 110, so that for feeding a wire portion corresponding to one coil spring 10 there is one revolution of the blade 135. The blade 135 may rotate at constant speed. However, it is also possible that the rotation of the blade 135 is intermittent. The latter option may enable higher speed of the cutting edge 139 when cutting the deformed wire 20 and thus higher precision of cutting.

[0029] The position of the rotary cutter 130 can be adjustable. In particular, the position of the rotary cutter 130 relative to the bending tools 115 of the winding stage 110 can be adjustable in the x-y-plane and/or along the z-direction. Accordingly, the position of the rotary cutter 130 can be adjusted along the axial direction of the coil springs 10 being produced and/or in a plane perpendicular to this axial direction. Further, the position of the rotation axis 135X of the blade 135 can be adjusted relative to the mandrel 137. In this way, the mechanism 100 can be adapted to various geometries of the coil springs 10 being produced. The adjustment may be electronically controlled, so that the adjustment can be accomplished in a reproducible and user-friendly manner.

[0030] As further illustrated, the mechanism 100 may be provided with a heating stage 140. The heating stage 140 may be used to heat the wire 20 before it is fed to the winding stage 110. Accordingly, deformation of the wire 20 in the winding stage 110 may be assisted and controlled by heating the wire 20. For heating the wire 20, the heating stage 140 is provided with a number of heaters 141, e.g., based on injecting electric current via electrodes, which heat the wire 20 due to electrical resistance of the wire 20. However, other types of heater could be used as alternative or in addition, e.g., inductive heaters. Further, the heating stage 140 is provided with guide elements 142 for guiding the wire 20 through the heating stage 140 while avoiding undesired deformation of the wire. It is however noted that the geometry of the heating stage 140 shown in Fig. 1A is merely exemplary and that other geometries could be used as well, e.g.,

with a higher or lower number of heaters 141 or with a different arrangement of the heaters 141.

[0031] As further illustrated in Figs. 1B and 1C, the mechanism 100 may also be provided with an output stage 150 which actively transfers the coil springs 10 from the winding stage 110. In the illustrated example, the output stage 150 includes a transport mechanism 160 which transports the coil springs 10 substantially along an axis of the coil springs 10 being produced. The transport mechanism 160 may for example transport the coil springs towards another component of an innerspring assembly machine, e.g., a pocketing mechanism which inserts the coil springs 10 into pockets of fabric material or an assembly mechanism which connects the coil springs 10 in a wire framework.

[0032] In the illustrated example, the transport mechanism 160 includes magnetic carriers 165 which are each driven by a belt drive 161 along a transport direction of the coil springs 10. The magnetic carriers 165 magnetically engage with the coil spring 10 being produced. As illustrated in Fig. 1C, this engagement occurs before the rotary cutter 130 cuts the deformed wire 20 and the coil spring 10 is released from the wire 20 fed to the winding stage 110. In this way, undesired movement of the coil spring 10 being produced can be avoided and the coil spring 10 thus reliably transferred from the winding stage 110. Alternatively, magnetic engagement of the magnetic carriers 165 with the coil spring 10 being produced can occur synchronously with or after the rotary cutter 130 cuts the deformed wire 20 and the coil spring 10 is released from the wire 20 fed to the winding stage 110. In the illustrated example, the number of the magnetic carriers 165 is two, each being driven by a separate belt drive 161. The magnetic carriers 165 and corresponding belt drives 161 may be arranged to engage different portions of the coil spring 10 being produced, e.g., the two end portions of the coil spring 10 or one end portion and a central portion of the coil spring 10. However, it is noted that other numbers of magnetic carriers 165 could be used as well, e.g., only one magnetic carrier. Still further, that other types of transport mechanism could also be used in the output stage 150, e.g., a transport mechanism based on a magnetic conveyor belt or a transport mechanism based on a non-magnetic carrier. As further illustrated, a stop 156 may be provided for stopping movement of the coil springs 10 by the transport mechanism 160. While the transport mechanism 160 transfers the coil spring 10 from the winding stage 110, the next coil spring 10 is already being formed in the winding stage 110.

[0033] Further, the output stage 150 is provided with a guide element 155. In the illustrated example, the guide element 155 is formed with V-shaped surfaces for engaging on an outer periphery of the coil spring 10 being produced. The guide element 155 guides movement of the deformed wire 20 coming from the winding stage 110 towards the transport mechanism 160. The position of the guide element 155 relative to the winding stage 110

and to the transport mechanism 160 may be adjustable to allow precise adaptation to different geometries of the coil springs 10 being produced.

[0034] It is noted that for the sake of a better overview, Fig. does not illustrate elements of the rotary cutter 130 and Figs. 1B and 1C do not illustrate the bending tools 115 of the winding stage 110.

[0035] Figs. 3A, 3B, and 3C further illustrate an exemplary implementation of the blade 135 of the rotary cutter 130. In particular, Fig. 3A shows a perspective view of the blade 135 and the rotary shaft 136 of the blade 135. Fig. 3B shows a plan view of the blade 135, taken in a plane perpendicular to the rotation axis of the blade 135. Fig. 3C shows a sectional view of the rotary shaft 136 and the blade 135, taken along line A-A of Fig. 3B.

[0036] As illustrated, the blade 135 is formed on a terminal surface of the rotary shaft 136. The rotary shaft 136 and the blade 135 are thus formed as a unitary component. Rotation of the blade 135 about the rotation axis 135X can thus be directly driven by the rotary shaft 136.

[0037] As further illustrated, a protrusion 138 is formed on a peripheral portion of the blade 135. In a radial direction from the rotation axis 135X, the protrusion 138 extends further outward from the cutting edge 139 of the blade 135. During rotation of the blade 135, the protrusion engages between two coil windings of the deformed wire 20 and separate the two coil windings, while the cutting edge 139 cuts the deformed wire 20 in one of these coil windings. This situation is schematically illustrated in Fig. 1C. The rotational speed of the blade 135 when cutting the deformed wire 20 is set in such a way that velocity of the cutting edge 139 exceeds the speed of feeding the wire 20, which in turn defines the velocity of the wire portion being cut.

[0038] As further illustrated, the blade 135 is provided with slanted outer surfaces 135A and 135B. These slanted outer surfaces 135A, 135B may be formed in a thread-like shape. The slanted outer surfaces 135A, 135B may help to avoid that the rotating blade 135 interferes with the coil spring 10 being formed in the winding stage 110. Further, the slanted outer surfaces 135A, 135B may guide the deformed wire 20, so that the coil winding in which cutting is to be performed is reliably brought into contact with the cutting edge 139.

[0039] Fig. 4 shows a flowchart for schematically illustrating a method of producing coil springs, such as the above-mentioned coil springs 10. The method may for example be performed by the above-mentioned mechanism 130.

[0040] At step 410, a wire is feed to a winding stage, e.g., like explained above for the feeding of the wire 20 to the winding stage 110. The wire may be heated or unheated. The feeding of the wire to the winding stage is performed at constant speed. Alternatively, the feeding of the wire to the winding stage could be accomplished in a single-step manner, e.g., by feeding a wire portion corresponding to one coil spring into the winding stage and then stopping the feeding until producing the next

coil spring, or in an intermittent manner, e.g., by stopping the feeding of the wire also during production of the coil spring.

[0041] At step 420, the wire is engaged in the winding stage to deform the wire to coil windings as the wire moves through the winding stage. For example, the wire can be engaged by one, two, or more bending tools of the winding stage, such as the above-mentioned bending tools 115. One or more of such bending tools may be motor-driven, so that the position of engaging the wire can be changed in the course of the winding process.

[0042] At step 430, the deformed wire is cut into portions forming separate coil springs, such as the above-mentioned coil springs 10. The cutting of the wire is performed by a blade rotating about a stationary rotation axis, such as explained for the above-mentioned blade 135 which rotates about rotation axis 135X. While cutting the deformed wire, the constant speed of feeding the wire to the winding stage can be maintained. The cutting of the deformed wire produces a separate portion of the deformed wire 20, corresponding to a single coil spring. When cutting the deformed wire, the engagement of the deformed wire with one or more bending tools of the winding stage may be maintained. In some scenarios, the bending tool engaging the wire may be driven to move the wire to a position in which the rotary cutter cuts the deformed wire. For example, such bending tool may be driven to move during the process of winding the wire, thereby conveying a desired geometry to the coil spring being produced. At the end of the winding process, the bending tool may be driven to move the deformed wire towards the rotary cutter, so that the wire can be cut at a well-defined position. This movement may at the same time assist in producing the coil spring with more densely arranged coils at its end.

[0043] At step 440, the coil spring produced at step 430 is transferred from the winding stage. This may be accomplished by a transport mechanism, such as the above-mentioned transport mechanism 160. The transport mechanism may use one or more carriers for engaging with a portion of the coil spring and moving the coil spring from the winding stage 110, such as the above-mentioned carriers 165. The one or more carriers may be magnetic or non-magnetic. A guide element may guide movement of the deformed wire in the winding stage and towards the transport mechanism. As for example explained for the above-mentioned guide element 155, the guide element may have V-shaped surfaces for engaging on an outer periphery of the coil spring. Engagement of the one or more carriers with the deformed wire may occur before the deformed wire is cut by the rotating blade.

[0044] It is noted that the above examples are susceptible to various modifications. For example, the illustrated mechanism and method may be used to produce various kinds of coil springs, e.g., barrel-shaped coil springs, cylindrically shaped coil springs, or hourglass shaped coil springs. Further, the produced coil springs may have var-

ious kinds of geometries, e.g., various coil winding diameters, various pitches, various heights, or the like. The bending tools used in the winding stage may be selected and configured according to the specific type and geometry of coil spring to be produced. Still further, the output stage may provide an interface to various other kind of machinery processing or otherwise handling coil springs, e.g., machinery for producing innerspring units. Such innerspring units may consist of pocket springs formed by enclosing the coil springs in fabric material or coil springs connected in an open wire framework.

Claims

1. A mechanism (100) for producing coil springs (10), the mechanism (100) comprising:
 - a winding stage (110) for engaging with a wire (20) and deforming the wire (20) to coil windings as the wire (20) moves through the winding stage (110);
 - a feed mechanism (120) configured to feed the wire (20) to the winding stage (110); and
 - a rotary cutter (130) configured to cut the deformed wire (20) into portions forming separate coil springs (10), wherein the rotary cutter (130) comprises a blade (135) which is driven for rotation about a stationary rotation axis (135X),

characterized in that

 - the blade (135) comprises a protrusion (138) configured to engage between two coil windings of the deformed wire (20) and separate the two coil windings as the blade (135) rotates.
2. The mechanism (100) according to claim 1, wherein the feed mechanism (120) is configured to maintain a constant speed of feeding the wire (20) while the rotary cutter (130) cuts the deformed wire (20).
3. The mechanism (100) according to claim 1 or 2, further comprising:
 - a mandrel (137) for cooperating with the blade (135) to cut the wire (20).
4. The mechanism (100) of claim 3, wherein a position of the mandrel (137) relative to the rotation axis (135X) is adjustable.
5. The mechanism (100) according to any one of the preceding claims, wherein a position of the rotary cutter (130) relative to the winding stage (110) is adjustable.
6. The mechanism (100) according to any one of the preceding claims,

wherein the blade (135) is formed on a terminal surface of a shaft portion (136) driven to rotate about the rotation axis (135X).

7. The mechanism (100) according to any one of the preceding claims, 5

wherein the winding stage (110) comprises at least one bending tool (115) which engages the wire (20) at positions set according to a geometry of the coil springs (10) being produced, wherein the winding stage (110) is configured to maintain engagement of the at least one bending tool (115) with the deformed wire (20) while the rotary cutter (130) cuts the deformed wire (20). 10

8. The mechanism (100) according to any one of the preceding claims, wherein the least one bending tool (115) is driven to move the wire (20) to a position in which the rotary cutter (130) cuts the deformed wire (20). 20

9. The mechanism (100) according to any one of the preceding claims, further comprising: a heating stage (140) configured to heat the wire (20) before feeding into the winding stage (110). 25

10. The mechanism (100) according to any one of the preceding claims, further comprising: 30

an output stage (150) for transferring the coil springs (10) from the mechanism (100), wherein the output stage (150) comprises a guide element (155) for guiding movement of the deformed wire (20) in the winding stage (110) and towards a transport mechanism (160). 35

11. The mechanism (100) according to any one of the preceding claims, wherein the transport mechanism (160) comprises at least one magnetic carrier (165) for engaging with the deformed wire (20) and moving the coil spring (10) from the winding stage (110). 40

12. The mechanism (100) according to claim 11, wherein the output stage (150) is configured to cause engagement of the at least one magnetic carrier (165) with the deformed wire (20) before the deformed wire (20) is cut by the rotary cutter (130) to release the coil spring (10) being produced. 50

13. A method of producing coil springs (10), the method comprising: 55

- feeding a wire (20) to a winding stage (110);
- engaging the wire (20) in the winding stage (110) to deform the wire (20) to coil windings as

the wire (20) moves through the winding stage (110); and

- by a blade (135) rotating about a stationary rotation axis (135X), cutting the deformed wire (20) into portions forming separate coil springs (10).

characterized in that the method is performed by a mechanism (100) according to any one of claims 1 to 12.

Patentansprüche

1. Mechanismus (100) zum Herstellen von Schraubenfedern (10), wobei der Mechanismus (100) umfasst:

eine Wickelstufe (110) zum in Eingriff Bringen eines Drahts (20) und zum Verformen des Drahtes (20) zu Spulenwindungen, wenn sich der Draht (20) durch die Wickelstufe (110) bewegt; einen Vorschubmechanismus (120), der ausgestaltet ist, um den Draht (20) der Wickelstufe (110) zuzuführen; und

einen Rotationsschneider (130), der ausgestaltet ist, um den verformten Draht (20) in Abschnitte zu schneiden, die separate Schraubenfedern (10) bilden,

wobei der Rotationsschneider (130) eine Klinge (135) umfasst, die zur Rotation um eine stationäre Rotationsachse (135X) angetrieben wird, **dadurch gekennzeichnet,**

dass die Klinge (135) einen Vorsprung (138) umfasst, der ausgestaltet ist, um zwischen zwei Spulenwindungen des verformten Drahts (20) in Eingriff zu kommen und die beiden Spulenwindungen zu trennen, wenn die Klinge (135) rotiert.

2. Mechanismus (100) nach Anspruch 1, wobei der Vorschubmechanismus (120) ausgestaltet ist, um eine konstante Geschwindigkeit für den Vorschub des Drahtes (20) beizubehalten, während der Rotationsschneider (130) den verformten Draht (20) schneidet. 45

3. Mechanismus (100) nach Anspruch 1 oder 2, darüber hinaus umfassend: einen Dorn (137) zum Zusammenwirken mit der Klinge (135), um den Draht (20) zu schneiden. 50

4. Mechanismus (100) nach Anspruch 3, wobei eine Position des Dorns (137) relativ zu der Rotationsachse (135X) einstellbar ist.

5. Mechanismus (100) nach einem der vorhergehenden Ansprüche, wobei eine Position des Rotationsschneiders (130)

relativ zu der Wickelstufe (110) einstellbar ist.

6. Mechanismus (100) nach einem der vorhergehenden Ansprüche, wobei die Klinge (135) an einer Endfläche eines Wellenabschnitts (136) ausgebildet ist, der zur Rotation um die Rotationsachse (135X) angetrieben wird. 5
7. Mechanismus (100) nach einem der vorhergehenden Ansprüche, wobei die Wickelstufe (110) mindestens ein Biegewerkzeug (115) umfasst, das den Draht (20) an Positionen in Eingriff bringt, die entsprechend einer Geometrie der herzustellenden Schraubenfedern (10) eingestellt sind, wobei die Wickelstufe (110) ausgestaltet ist, um den Eingriff des mindestens einen Biegewerkzeugs (115) mit dem verformten Draht (20) aufrechtzuerhalten, während der Rotationsschneider (130) den verformten Draht (20) schneidet. 10 15 20
8. Mechanismus (100) nach einem der vorhergehenden Ansprüche, wobei das mindestens eine Biegewerkzeug (115) angetrieben wird, um den Draht (20) in eine Position zu bewegen, in der der Rotationsschneider (130) den verformten Draht (20) schneidet. 25
9. Mechanismus (100) nach einem der vorhergehenden Ansprüche, der darüber hinaus umfasst: eine Heizstufe (140), die ausgestaltet ist, um den Draht (20) vor dem Einführen in die Wickelstufe (110) zu erwärmen. 30
10. Mechanismus (100) nach einem der vorangehenden Ansprüche, der darüber hinaus umfasst: eine Ausgabestufe (150) zur Übergabe der Schraubenfedern (10) von dem Mechanismus (100), wobei die Ausgabestufe (150) ein Führungselement (155) zum Führen einer Bewegung des verformten Drahtes (20) in der Wickelstufe (110) und in Richtung eines Transportmechanismus (160) umfasst. 35 40
11. Mechanismus (100) nach einem der vorhergehenden Ansprüche, wobei der Transportmechanismus (160) mindestens einen magnetischen Träger (165) umfasst, um mit dem verformten Draht (20) in Eingriff zu kommen und die Schraubenfeder (10) von der Wickelstufe (110) zu bewegen. 45 50
12. Mechanismus (100) nach Anspruch 11, wobei die Ausgabestufe (150) ausgestaltet ist, um einen Eingriff des mindestens einen Magnetträgers (165) mit dem verformten Draht (20) zu bewirken, bevor der verformte Draht (20) von dem Rotationsschneider (130) geschnitten wird, um die hergestell-

te Schraubenfeder (10) freizugeben.

13. Verfahren zum Herstellen von Schraubenfedern (10), wobei das Verfahren umfasst: 5
- Zuführen eines Drahtes (20) zu einer Wickelstufe (110);
 - in Eingriff Bringen des Drahtes (20) in der Wickelstufe (110), um den Draht (20) zu Schraubenwindungen zu verformen, wenn sich der Draht (20) durch die Wickelstufe (110) bewegt; und
 - Schneiden des verformten Drahtes (20) in Abschnitte, die separate Schraubenfedern (10) bilden, durch eine Klinge (135), die um eine stationäre Rotationsachse (135X) rotiert, 10 15 20
- dadurch gekennzeichnet,**
dass das Verfahren durch einen Mechanismus (100) nach einem der Ansprüche 1 bis 12 durchgeführt wird.

Revendications

1. Mécanisme (100) de production de ressorts hélicoïdaux (10), le mécanisme (100) comprenant :
- un étage d'enroulement (110) destiné à venir en prise avec un fil (20) et à déformer le fil (20) vers des enroulements de bobine au fur et à mesure que le fil (20) se déplace à travers l'étage d'enroulement (110) ;
 - un mécanisme de fourniture (120) conçu pour fournir le fil (20) à l'étage d'enroulement (110) ;
 - et
 - un dispositif de coupe rotatif (130) conçu pour couper le fil déformé (20) en parties afin de former des ressorts hélicoïdaux (10) séparés, dans lequel le dispositif de coupe rotatif (130) comprend une lame (135) qui est entraînée en rotation autour d'un axe de rotation fixe (135X), **caractérisé en ce que** la lame (135) comprend une protubérance (138) conçue pour venir en prise entre deux enroulements de bobine du fil déformé (20) et séparer les deux enroulements de bobine lorsque la lame (135) tourne. 35 40 45 50
2. Mécanisme (100) selon la revendication 1, dans lequel le mécanisme de fourniture (120) est conçu pour maintenir une vitesse constante de fourniture du fil (20) pendant que le dispositif de coupe rotatif (130) coupe le fil déformé (20). 55
3. Mécanisme (100) selon la revendication 1 ou 2, comprenant en outre : un mandrin (137) destiné à coopérer avec la lame

- (135) pour couper le fil (20).
4. Mécanisme (100) selon la revendication 3, dans lequel une position du mandrin (137) par rapport à l'axe de rotation (135X) est réglable.
5. Mécanisme (100) selon l'une quelconque des revendications précédentes, dans lequel une position du dispositif de coupe rotatif (130) par rapport à l'étage d'enroulement (110) est réglable.
6. Mécanisme (100) selon l'une quelconque des revendications précédentes, dans lequel la lame (135) est formée sur une surface terminale d'une partie d'arbre (136) entraînée en rotation autour de l'axe de rotation (135X).
7. Mécanisme (100) selon l'une quelconque des revendications précédentes,
- dans lequel l'étage d'enroulement (110) comprend au moins un outil de pliage (115) qui vient en prise avec le fil (20) à des positions définies en fonction de la géométrie des ressorts hélicoïdaux (10) en cours de production, dans lequel l'étage d'enroulement (110) est conçu pour maintenir la mise en prise de l'au moins un outil de pliage (115) avec le fil déformé (20) pendant que le dispositif de coupe rotatif (130) coupe le fil déformé (20).
8. Mécanisme (100) selon l'une quelconque des revendications précédentes, dans lequel l'au moins un outil de pliage (115) est entraîné pour déplacer le fil (20) vers une position dans laquelle le dispositif de coupe rotatif (130) coupe le fil déformé (20).
9. Mécanisme (100) selon l'une quelconque des revendications précédentes, comprenant en outre : un étage de chauffage (140) conçu pour chauffer le fil (20) avant de le fournir dans l'étage d'enroulement (110).
10. Mécanisme (100) selon l'une quelconque des revendications précédentes, comprenant en outre : un étage de sortie (150) destiné à transférer les ressorts hélicoïdaux (10) du mécanisme (100), dans lequel l'étage de sortie (150) comprend un élément de guidage (155) destiné à guider le mouvement du fil déformé (20) dans l'étage d'enroulement (110) et vers un mécanisme de transport (160).
11. Mécanisme (100) selon l'une quelconque des revendications précédentes, dans lequel le mécanisme de transport (160) comprend au moins un support magnétique (165) destiné
- à entrer en prise dans le fil déformé (20) et à déplacer le ressort hélicoïdal (10) de l'étage d'enroulement (110).
12. Mécanisme (100) selon la revendication 11, dans lequel l'étage de sortie (150) est conçu pour permettre la mise en prise de l'au moins un support magnétique (165) avec le fil déformé (20) avant que le fil déformé (20) ne soit coupé par le dispositif de coupe rotatif (130) afin de libérer le ressort hélicoïdal (10) en cours de production.
13. Procédé de production de ressorts hélicoïdaux (10), le procédé comprenant :
- la fourniture d'un fil (20) à un étage d'enroulement (110) ;
 - la mise en prise du fil (20) dans l'étage d'enroulement (110) pour déformer le fil (20) vers des enroulements de bobine au fur et à mesure que le fil (20) se déplace à travers l'étage d'enroulement (110) ; et
 - par une lame (135) tournant autour d'un axe de rotation fixe (135X), la coupe du fil déformé (20) en parties formant des ressorts hélicoïdaux (10) séparés.
- caractérisé en ce que** le procédé est mis en oeuvre par un mécanisme (100) selon l'une quelconque des revendications 1 à 12.

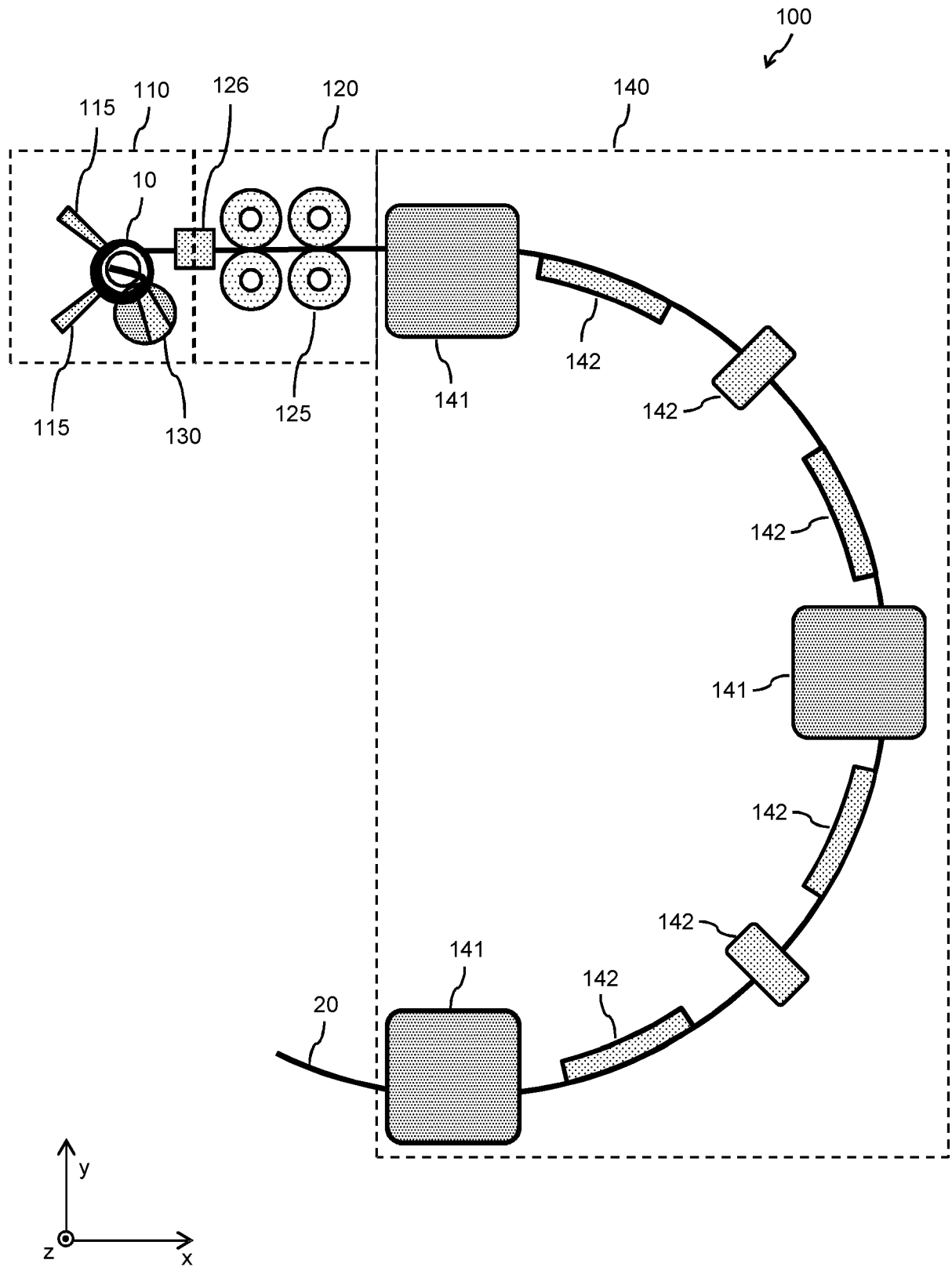

FIG. 1A

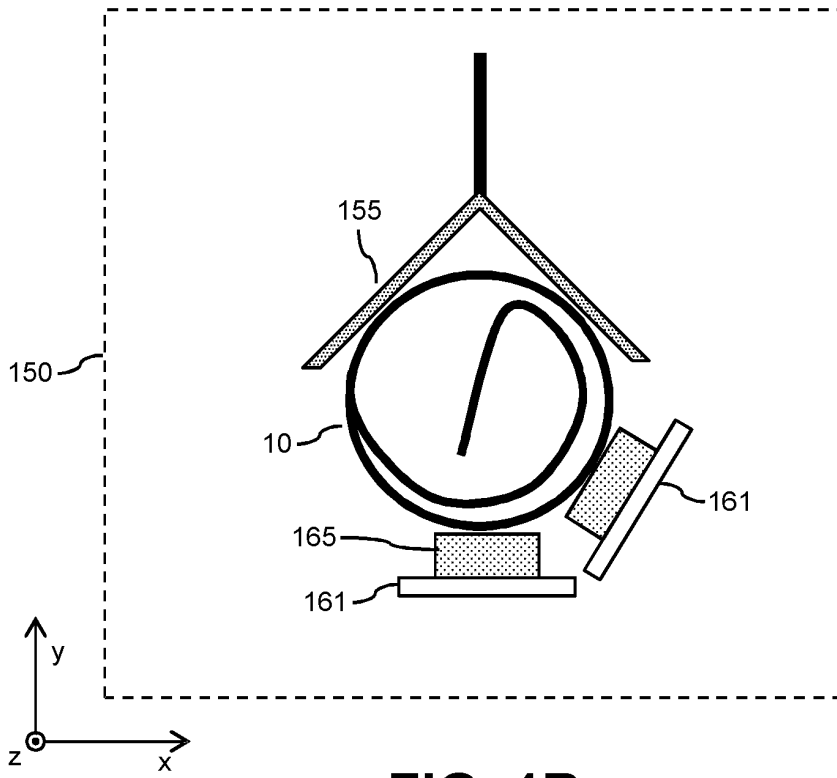

FIG. 1B

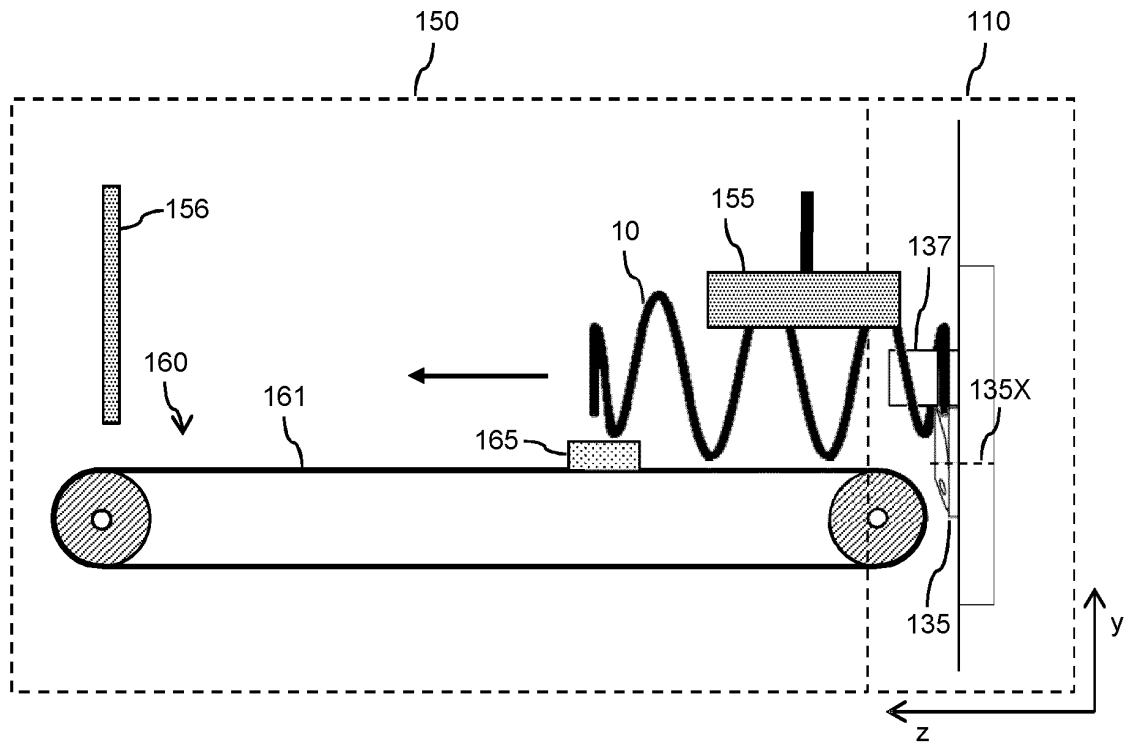

FIG. 1C

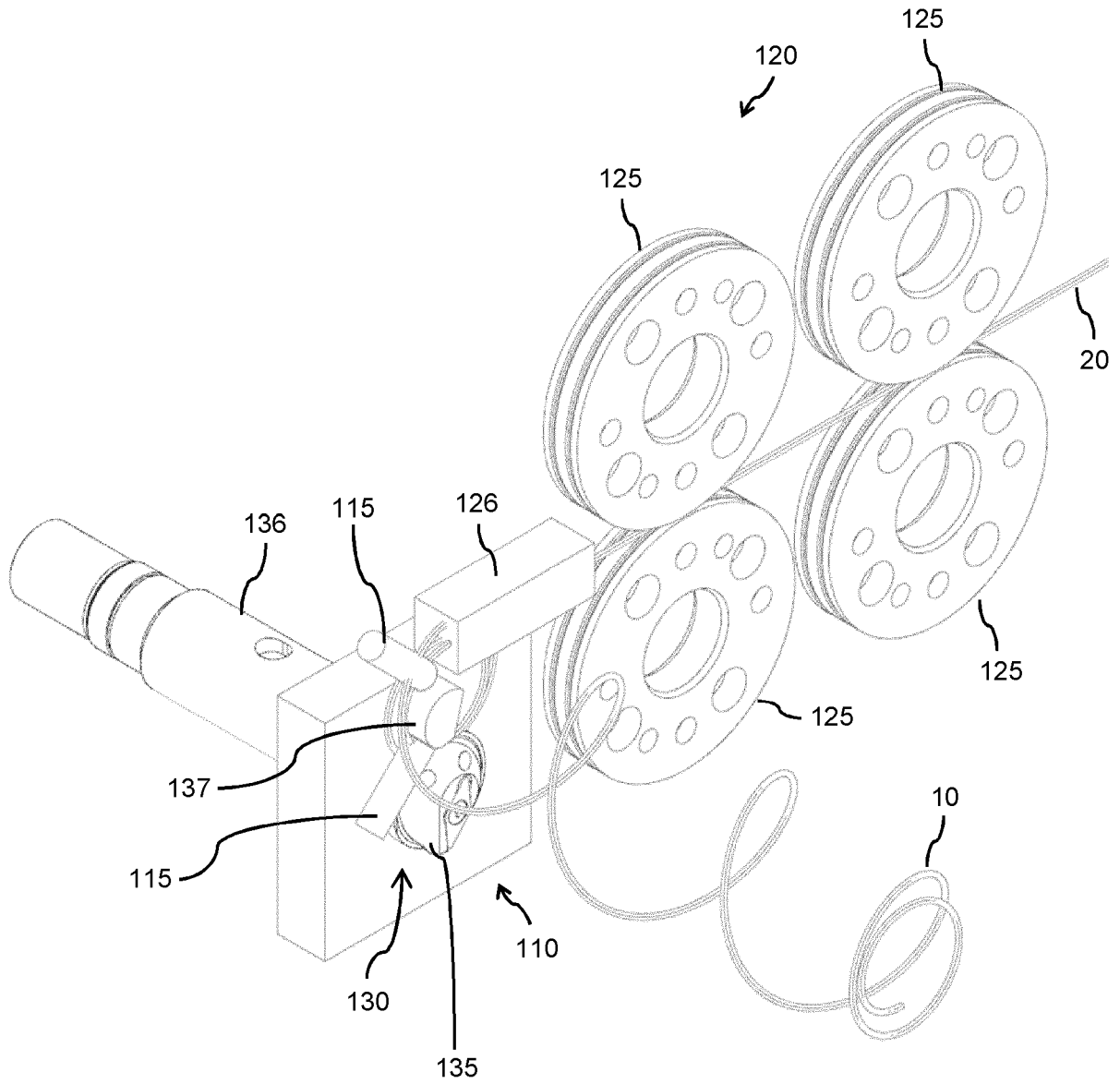

FIG. 2

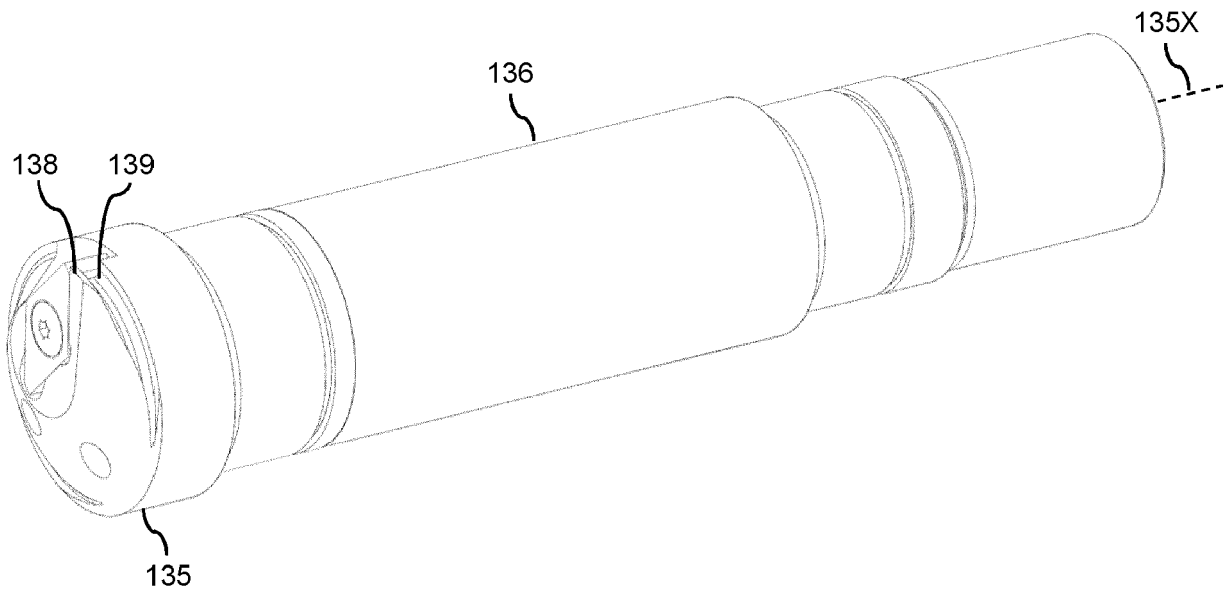

FIG. 3A

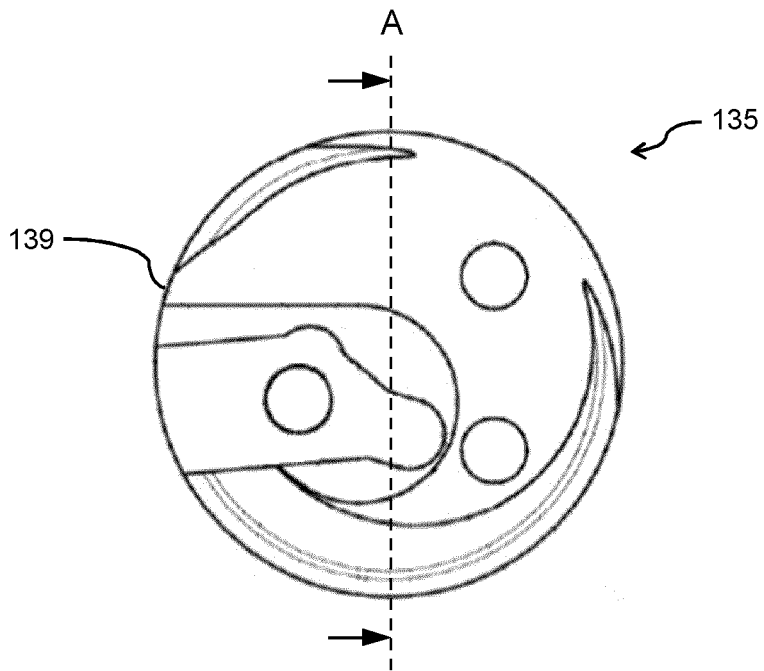

FIG. 3B

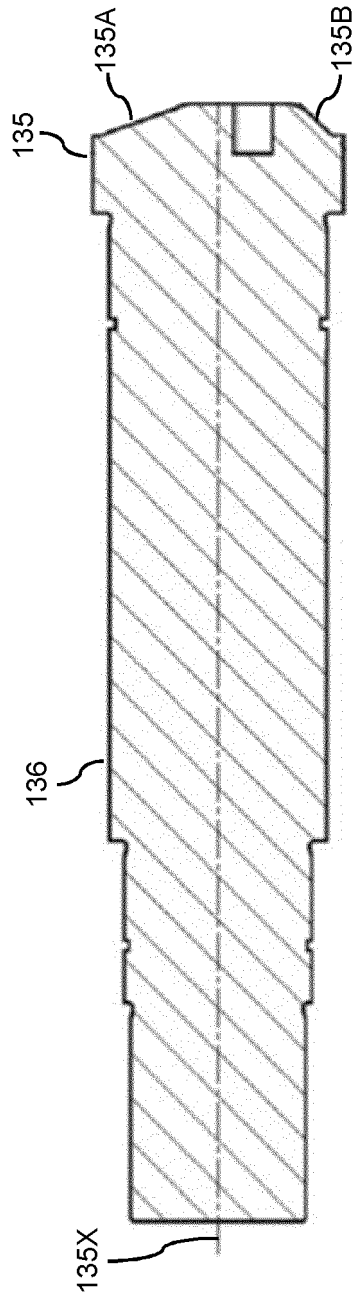

FIG. 3C

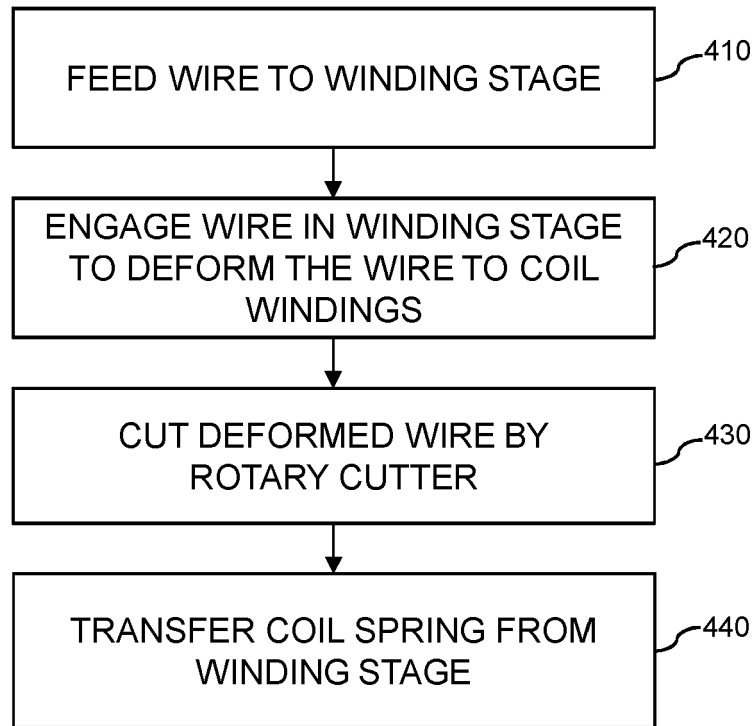

FIG. 4

REFERENCES CITED IN THE DESCRIPTION

This list of references cited by the applicant is for the reader's convenience only. It does not form part of the European patent document. Even though great care has been taken in compiling the references, errors or omissions cannot be excluded and the EPO disclaims all liability in this regard.

Patent documents cited in the description

- EP 3059025 A1 **[0003]**
- US 8978434 B2 **[0005]** **[0006]**
- US 2869640 A **[0005]**
- US 4986103 A **[0005]**
- DE 4040549 C1 **[0005]**
- EP 3059025 B1 **[0005]**
- DE 102012204513 B3 **[0005]**
- US 2019168287 A1 **[0005]**
- WO 2020138376 A1 **[0005]**