

(19)



(11)

EP 4 183 293 B1

(12)

EUROPEAN PATENT SPECIFICATION

(45) Date of publication and mention of the grant of the patent:

06.03.2024 Bulletin 2024/10

(51) International Patent Classification (IPC):

**A47B 57/52^(2006.01) A47B 96/06^(2006.01)
B21D 5/00^(2006.01)**

(21) Application number: **22199490.8**

(52) Cooperative Patent Classification (CPC):

**A47B 57/52; A47B 96/061; A47B 96/062;
A47B 96/068; B21D 53/36; A47B 2220/0041;
B21D 5/00**

(22) Date of filing: **04.10.2022**

(54) **SUPPORT DEVICE FOR FURNITURE SHELVES AND RELATED MANUFACTURING PROCESS**

STÜTZVORRICHTUNG FÜR MÖBELREGALE UND ENTSPRECHENDES
HERSTELLUNGSVERFAHREN

DISPOSITIF DE SUPPORT POUR ÉTAGÈRES DE MEUBLES ET PROCÉDÉ DE FABRICATION
CORRESPONDANT

(84) Designated Contracting States:

**AL AT BE BG CH CY CZ DE DK EE ES FI FR GB
GR HR HU IE IS IT LI LT LU LV MC ME MK MT NL
NO PL PT RO RS SE SI SK SM TR**

(72) Inventors:

- **CARNELOS, Luca**
Porcia (IT)
- **VERZIAGI, Davide**
Fontanafredda (PN) (IT)

(30) Priority: **19.11.2021 IT 202100029300**

(43) Date of publication of application:

24.05.2023 Bulletin 2023/21

(74) Representative: **Cercenà, Alice et al**

Propria S.r.l.
Via della Colonna, 35
33170 Pordenone (IT)

(73) Proprietor: **Italiana Ferramenta S.r.l.**

33070 Brugnera (PN) (IT)

(56) References cited:

DE-C- 362 297 US-A- 717 316

EP 4 183 293 B1

Note: Within nine months of the publication of the mention of the grant of the European patent in the European Patent Bulletin, any person may give notice to the European Patent Office of opposition to that patent, in accordance with the Implementing Regulations. Notice of opposition shall not be deemed to have been filed until the opposition fee has been paid. (Art. 99(1) European Patent Convention).

Description

TECHNICAL FIELD OF THE INVENTION

[0001] The present invention relates to a device for supporting shelves for furnishing elements, such as for example pieces of furniture, and the relative manufacturing process.

BACKGROUND OF THE INVENTION

[0002] Generally, pieces of furniture are made as parallelepiped-shaped bodies which define a compartment inside which there are positioned horizontal shelves extending between the sides of the piece of furniture and on which objects, foodstuffs, clothes etc. can be placed.

[0003] Support devices adapted to be associated with the sides of the piece of furniture so as to support the shelves in the inner compartment of a piece of furniture at a desired height are known.

[0004] Such supporting devices generally comprise a mounting pin, adapted to be inserted into a hole obtained on the side of the piece of furniture, and a support body, adapted to be arranged, in use, in the inner compartment of the piece of furniture, and on which the shelf can be placed.

[0005] US 717 316 A discloses a shelf support device made of wrought sheet metal and consisting of a vertical back plate provided with an integral rearwardly-projecting tubular boss near its upper end, two substantially triangular vertical side pieces integral with and lying at right angles to the back plate.

[0006] In particular, the body of the support device is L-shaped essentially formed by a pair of portions connected orthogonally, wherein a first portion is adapted to define a horizontal support surface for the shelf, while the second portion is adapted to define an abutment surface, adapted to abut, in use, against the inner surface of the side of the piece of furniture.

[0007] Usually, the body of the support device and the mounting pin are manufactured by moulding using zinc and aluminium alloy made of separate pieces, coupled subsequently, so as to manufacture pins of various diameter depending on the needs. Alternatively, supporting devices made of plastic or zinc alloy made of a single piece by moulding, are known.

[0008] However, when the diameter of the mounting pin is smaller than a given size, the latter is excessively fragile, and could break under the weight of the shelf. As a result, a solution currently used to overcome this drawback lies in providing the mounting pin made of steel, and subsequently coupling it to the support body made of zinc and aluminium alloy; however, this solution is rather demanding in terms of cost-effectiveness.

[0009] Therefore, the main task of the subject matter of the present invention is to overcome the drawbacks of the prior outlined above by providing a shelf support device that is simple and cost-effective to manufacture

and robust at the same time.

[0010] Within the scope of the task outlined above, an object of the present invention lies in obtaining a shelf support device that is easily adaptable to the needs.

[0011] Lastly but not least, an object is to provide an adjustable supporting device for pieces of furniture that attains the task and objects mentioned above by using standard and known installations, machines and equipment.

[0012] The task and the objects outlined above, as well as others which will be more apparent hereinafter, are achieved through a support device according to claim 1, and a manufacturing process according to claim 8. The subsequent claims define further characteristics of a support device according to the present invention which will be better illustrated in the description of particular, but not exclusive, embodiments, illustrated by way of non-limiting example in the attached drawings, wherein:

- 20 - figures 1A and 1B show - with perspective views from a different angle - a shelf support device according to a first embodiment of the present invention;
- figure 2A shows, with plan view, the flat sheet from which there can be obtained, through subsequent bending and deformation, the support device according to the previous figures;
- 25 - figure 2B shows, in perspective view, the support device according to the first embodiment, obtained from a manufacturing process according to the invention;
- 30 - figure 3 shows, in perspective view, a support device according to a second embodiment of the present invention;
- figure 4A shows, with plan view, the flat sheet from which there can be obtained, through subsequent bending and deformation, the support device according to figure 3;
- 35 - figure 4B shows, in perspective view, the support device according to the second embodiment, obtained from a manufacturing process according to the invention;
- 40 - figures 5A and 5B show, with perspective views with different angles, a support device according to third embodiment of the present invention;
- 45 - figure 6 shows, with plan view, the flat sheet from which there can be obtained, through subsequent bending and deformation, the support device according to figures 5A and 5B; and
- figures 7A and 7B show, with perspective views with different angles, a support device according to fourth embodiment of the present invention;
- figure 8 shows, with plan view, the flat sheet from which there can be obtained, through subsequent bending and deformation, the support device according to figures 7A and 7B.

DESCRIPTION OF THE INVENTION

[0013] In the description below, expressions such as "above", "below", "upper", "lower", "high", "low" or the like refer to a shelf support device according to the present invention in the standard operative configuration thereof, that is in use.

[0014] In particular with reference to figures 1A and 1B, there is shown a shelf support device 1 according to a first embodiment of the present invention, adapted to support a shelf on a support structure, such as for example a panel forming the side of the piece of furniture.

[0015] Said device 1 substantially comprises a mounting pin 10, adapted to be inserted into a hole obtained on said support structure at a desired mounting height, and a support body 20 comprising a pair of side walls 21, preferably essentially L-shaped and defining a top support surface 22 for said shelf, and a rear wall 23, from which there protrudes said mounting pin 10, defining an abutment surface 24 adapted to abut against said support structure, that is in particular the inner surface of the panel forming the side of the piece of furniture.

[0016] According to an advantageous characteristic of the present invention, said support device 1 is made as a single piece starting from a flat sheet 30, preferably made by metal, suitably shaped and then bent and deformed plastically, as explained in greater detail below, so as to define said mounting pin 10 and said support body 20.

[0017] As shown in figure 2A, said flat sheet 30 is preferably cut to define a shape extending along a prevalent extension line E preferably essentially straight and delimited by an upper edge line 30A and a lower edge line 30B, suitably shaped, and laterally by a pair of end edges 30C.

[0018] On said sheet 30 there can be advantageously defined at least a pair of first portions 31, a pair of second portions 32, a pair of third portions 33, and at least a first connecting portion 34, each continuously connected to the adjacent portions, that is uninterrupted, and delimitable with respect to the adjacent portions through respective delimitation lines, preferably extending transversely to said extension line E of the sheet 30, between said upper edge line 30A and said lower edge line 30B.

[0019] Advantageously, said delimitation lines may not be evident on the sheet 30, but they serve as reference for forming the support device 1, as explained in greater detail below. Alternatively, said delimitation lines may be defined by weakening portions adapted to facilitate the subsequent bending and deformation operations to obtain the device 1.

[0020] In particular, said first portions 31 are preferably L-shaped, being advantageously formed by a first section 31A extending essentially along said extension line E and by a second section 31B extending transversely with respect to said extension line E, continuously connected. The lower edge 31C of said first portions 31 may possibly have a shaped profile, for example curved.

[0021] Advantageously, said second portions 32 are essentially rectangular-shaped and they are preferably arranged so as to extend along a direction transversal to said extension line E, and said third portions 33, also essentially rectangular shaped, are preferably arranged so as to extend along said extension line E.

[0022] Preferably, said delimitation lines are adapted to define corresponding bending axes X1, X2, X3, around which the sheet 30 can be bent.

[0023] In particular, as explained in greater detail below, said first portions 31 are adapted to form said side walls 21 of said support body 20, said second portions 32 are adapted to form said rear wall 23 of said support body 20 and said third portions 33 are adapted to form said mounting pin 10.

[0024] It should be observed that in the description below the expression bend or bending is used to indicate a mechanical processing which provides for a plastic deformation of a sheet obtained by rotating a portion of the sheet around a bending axis according to a bending angle of about 90°.

[0025] Otherwise, the expression plastic deformation is used to indicate a mechanical processing different from the bending defined above, obtained with or without changing the thickness of the starting sheet, which provides for a rotation of a portion of the sheet around a bending axis according to a bending angle different than 90° and/or an extension/compression of the material so as to allow the formation of volumes that cannot be easily developed by a flat sheet.

[0026] Specifically, said flat sheet 30 is shaped so as to have a connecting portion 34, which - in this first embodiment - is advantageously rectangular-shaped and it is arranged essentially centrally, from which the portions of said pair of first portions 31 depart, on opposite sides each continuously connected to the connecting portion 34 but being delimitable with respect to the latter through a respective first delimitation line 41.

[0027] The opposite ends of said first portions 31 are connected to a respective portion of said second portions 32, being delimitable by the latter through second delimitation lines 42, and to which there are then connected the portions of said pair of third portions 33, which therefore form the opposite ends of the sheet 30, and they are delimitable with respect to said second portions 32 through third delimitation lines 43.

[0028] The process for obtaining a support device 1 according to the present invention comprises the following steps:

- a) arranging a flat sheet 30 cut to define a shape extending along a prevalent extension line E and comprising at least a pair of first portions 31, a pair of second portions 32, a pair of third portions 33 and at least a connecting portion 34 each continuously connected to the adjacent portions and delimitable with respect to the same through delimitation lines extending transversely with respect to said exten-

sion line E adapted to define corresponding bending axes X1, X2, X3;

b) performing a plurality of bendings around said bending axes X1, X2, X3 so that the adjacent portions are lying on mutually orthogonal planes.

[0029] In particular, as shown in figure 2B, during said step b) the operation is carried out in a manner such that said connecting portion 34 is lying on a first lying plane P1, said first portions 31 are arranged on a pair of parallel and facing second planes P2, essentially orthogonal to said first plane P1, to form the side walls 21 of said support body 20, said second portions 32 are lying on the same third plane P3 perpendicular to said second planes P2 and with said edges approached, so as to form the rear wall 23 of said support body 20 of the device 1, and lastly arrange said third portions 33 along a pair of parallel and facing fourth planes P4 which are orthogonal to said third plane P3.

[0030] The process further comprises a step c) in which said third portions 33 are advantageously plastically deformed so as to draw them around a cylindrical body to essentially form the mounting pin 10.

[0031] Advantageously, the support surface 22 of said support device 1 is therefore formed by the upper edges of the first sections 31A of the first portions 31 and of the connecting portion 34, while said abutment surface 24 is formed by the surface facing outwards said second portions 32.

[0032] The stiffness of the support device 1 is guaranteed at the time of use by inserting the portions forming the mounting pin 10 into the mounting hole obtained on the surface of the side of the piece of furniture, therefore preventing the device 1 from opening.

[0033] Possibly, the side edges 35 - mutually approached in use - of said second portions 32 may have shaped coupling profiles, advantageously configured so as to penetrate into each other to prevent the unwanted moving away of the third portions 33 or the relative movement of the second portions 32 when the device 1 is in use, particularly in case of heavy shelves.

[0034] For example, as shown in figure 2A, the edge 35A of one of said second portions 32 has a profile defined by a first protrusion and by a pair of first recesses, arranged on opposite sides with respect to said first protrusion and extending along inclined directions, while the edge 35B of the other of said second portions 32 is counter-shaped with respect to said edge 35A and therefore it has a second protrusion, adapted to receive said first protrusion, and a pair of second protrusions, extending along inclined directions, adapted to be received in the pair of first recesses.

[0035] Furthermore, said second portions 32 may have tabs 36 protruding from the upper edges and adapted to be positioned, when the support device is made and installed on the support structure, between the surface of the side and the head edge of the shelf, so as to prevent the device 1 from slipping off from the mounting hole,

inclining, and yielding under the load applied on the shelf.

[0036] Advantageously, the process for obtaining a support device 1 described above is known in the sheet processing industry under the name of pitch mould, in which the various cutting, bending and deformation steps can be carried out simultaneously or with a sequence other than the one indicated above.

[0037] Figure 3 shows a support device 1' according to a second embodiment of the present invention. Also in this embodiment, said device 1' substantially comprises a mounting pin 10, adapted to be inserted into a mounting hole obtained on said support structure at a desired mounting height, and a support body 20 comprising a pair of side walls 21, preferably essentially L-shaped and defining a top support surface 22 for said shelf, and a rear wall 23, from which there protrudes said mounting pin 10, defining an abutment surface 24 adapted to abut against said support structure, that is in particular the inner surface of the panel forming the side of the piece of furniture.

[0038] Also said device 1' is made as a single piece starting from a flat sheet 30', preferably metal shaped and then suitably bent and deformed plastically as explained in greater detail below.

[0039] As shown in figure 4A, similarly to the previous embodiment, said flat sheet 30' extends along a prevalent essentially straight extension line E, and it has a pair of first portions 31, a pair of second portions 32, a pair of third portions 33, and a connecting portion 34', continuously connected to each other and delimited by delimitation lines 41, 42, 43.

[0040] In particular, said first portions 31 are preferably L-shaped, being advantageously formed by a first section 31A extending along the axis E and by a second section 31B extending transversely with respect to said axis E, continuously connected. The lower edge 31C of said first portions 31 may possibly have a shaped profile, for example curved.

[0041] Advantageously, said second portions 32 are essentially rectangular-shaped and they are preferably arranged so as to extend along a direction transversal to the axis E, and said third portions 33, also essentially rectangular-shaped, are preferably arranged so as to extend along the axis E.

[0042] However, in this case, said sheet 30' is shaped so as to have said connecting portion 34' advantageously arranged centrally, and from which the portions of said pair of third portions 33 depart on opposite sides, each separated from the connecting portion 34' by a respective first delimitation line 41 extending transversely with respect to said extension line E.

[0043] The opposite ends of said third portions 33 are connected, through second delimitation lines 42 extending transversely with respect to said extension line E, to a respective portion of said second portions 32, to which they are then connected, through third delimitation lines 43 extending transversely with respect to said extension line E, the portions forming said pair of first portions 31,

which therefore form the opposite ends of the sheet 30'.

[0044] The process for obtaining a support device 1' is similar to the one provided for forming the support device 1 according to the preceding embodiment, and it comprises the following steps, adapted to be carried out even with a different sequence or simultaneously:

- a) providing a flat sheet 30' cut to define the shape illustrated above;
- b) carrying out a plurality of bendings around bending axes X1, X2, X3 defined by the delimitation lines 41, 42, 43 of the various portions so that the adjacent portions are lying on mutually orthogonal planes, so that said first portions 31 form said side walls 21 of said support body 20, said second portions 32 form said rear wall 23 of said support body 20;
- c) plastically deforming said third portions 33 so as to draw them around a cylindrical body to obtain said mounting pin 10.

[0045] As shown in figure 4B, during said step b) the operation is carried out in a manner such that said connecting portion 34' is essentially lying on a first lying plane P1, said first portions 33 are arranged on a pair of second parallel and facing planes P2, which are essentially orthogonal to said first plane P1, and they are then drawn so as to form said mounting pin 10, said second portions 32 are lying on the same third plane P3 perpendicular to said second planes P2 and with the edges approached to form the rear wall 23 of said support body 20 of the device 1', and lastly said first portions 31 are lying along a pair of fourth parallel and facing planes P4, which are orthogonal to said third plane P3, to form the side walls 21 of said support body 20.

[0046] Advantageously, the support surface 22 of said support device 1' is therefore formed by the upper edges of the first sections 31A of the first portions 31, while said abutment surface 24 is formed by the surface facing outwards said second portions 32.

[0047] Also in this embodiment, the edges 35 - mutually approached in use - of said second portions 32 may have shaped coupling profiles, advantageously shaped in a manner such to penetrate into each other to prevent the unwanted moving away of the third portions 33 or the relative movement of the second portions 32 when the device 1' is in use, particularly in case of heavy shelves.

[0048] Furthermore, also in this embodiment, said second portions 32 may have tabs 36 protruding from the upper edges and adapted to be positioned, when the support device has been made and installed on the support structure, between the surface of the side and the head edge of the shelf, so as to prevent the device 1 from slipping off from the mounting hole, inclining, and collapsing under the load applied on the shelf.

[0049] Figures 5A and 5B show the support device 1'' according to a third embodiment of the present invention. Unlike the previous embodiments, the starting flat sheet 30'' has a shape extending transversely to the non-

straight extension line E but with a partially curved development; furthermore, said sheet 30'' comprises a connecting portion 34'' extending transversely with respect to the extension line E and it continuously connects the lower edges 31C of the first portions 31, as shown in figure 6.

[0050] The portions of said pair of first portions 31 depart from said connecting portion 34'', on opposite sides, each delimitable with respect to the latter through a respective first delimitation line 41 extending substantially transversely to the extension line E. In this case, said first delimitation lines 41 are not straight but they are adapted to define the corresponding first rotation axis X1 following the operation for restoring the straightness of the sheet 30'', as explained in greater detail below.

[0051] The opposite ends of said first portions 31 are connected to a respective portion of said second portions 32, being delimitable by the latter through second delimitation lines 42, and to which there are then connected the portions of said pair of third portions 33, which therefore form the opposite ends of the sheet 30'', and they are delimitable with respect to said second portions 32 through third delimitation lines 43.

[0052] The process for manufacturing the device 1'' which is similar to the one already described relating to the first embodiment, advantageously comprises a further step a1), to be carried out preferably before or simultaneously with said step b), in which at least said second portions 31 and said connecting portion 34'' are plastically deformed to restore the straightness of the section with curved development of said extension line E.

[0053] Furthermore, the process is preferably completed with a further step d1), which can be carried out before or after carrying out step c), wherein said connecting portion 34'' is plastically deformed so that it adheres to the lower edges 31C of said first portions 31, essentially forming a lower finishing wall 26 for the support body of the device 1''.

[0054] Lastly, figures 7A and 7B show a support device 1''' according to a fourth embodiment of the present invention. In this embodiment, the starting flat sheet 30''' has a shape essentially similar to that of the sheet 30 of the first embodiment but it differs from the latter due to the fact that it comprises a second connecting portion 37 which extends from the lower edge of one of the portions forming said pair of second portions 32, as shown in figure 8.

[0055] The process for manufacturing the device 1''' is similar to the one already described relating to the first embodiment but it is completed by a step d2) in which said second connecting portion 37 is plastically deformed with progressive bending so that it adheres to the lower edges 31C of said first portions 31, essentially forming a lower finishing wall 26 for the support body of the device 1'''.

[0056] In all embodiments shown above, a covering cap (not shown in the figures) may be provided for aesthetic purposes and/or with anti-slip function, in particular

should the shelf to be supported be made of glass.

[0057] In the light of the above, it is clear that a support device and a relative manufacturing process according to the present invention attains the objects and advantages initially set forth. As a matter of fact, there has been designed a support device which is significantly simple and cost-effective to manufacture but at the same time robust and easily adaptable depending on the needs.

[0058] Obviously, the invention is susceptible of numerous modifications or variants without departing from the scope of protection of the present invention, as defined by any one of the attached claims.

[0059] Furthermore, the materials used to implement the present invention, as well as the shapes and dimensions of the individual components, may be the most appropriate depending on the specific requirements.

Claims

1. Shelf support device (1, 1', 1", 1'''), comprising a mounting pin (10) adapted to be inserted in a hole obtained on a support structure and a support body (20) comprising a pair of side walls (21) defining a top support surface (22) for said shelf and a rear wall (23) defining an abutment surface (24) adapted to abut against said support structure, **characterized in that** said mounting pin (10) and said support body (20) are obtained as single piece from a flat sheet (30, 30', 30", 30'''), extending along a prevalent extension line (E) and shaped so as to define at least a pair of first portions (31), a pair of second portions (32), a pair of third portions (33) and at least a first connecting portion (34, 34', 34''), each continuously connected to the adjacent portions and delimitable with respect to the same through respective delimitation lines (41, 42, 43), extending transversely with respect to the extension line (E) of said flat sheet (30, 30', 30", 30''').
2. Support device (1, 1', 1", 1''') according to claim 1, wherein said first portions (31) are adapted to form said side walls (21) of said support body (20), said second portions (32) are adapted to form said rear wall (23) of said support body (20) and said third portions (33) are adapted to form said mounting pin (10).
3. Support device (1, 1', 1", 1''') according to any one of the preceding claims, wherein said first portions (31) are essentially L-shaped and are defined by a first section (31A) extending essentially along said extension line (E) and by a second section (31B) extending transversely with respect to said extension line (E), said first section (31A) and said second section (31B) being continuously connected.
4. Support device (1, 1', 1", 1''') according to any one

of the preceding claims, wherein said second portions (32) are essentially rectangular-shaped and they are arranged so as to extend transversely along a direction transversal to the extension line (E).

5. Support device (1, 1', 1", 1''') according to any one of the preceding claims, wherein the side edges (35, 35A, 35B) of said second portions (32) have coupling profiles shaped so as to penetrate one in the other.
6. Support device (1, 1', 1", 1''') according to any one of the preceding claims, wherein said second portions (32) each comprise a tab (36) projecting from the top edge and adapted to be disposed, when the device is in use, between the surface of the support structure and a head edge of the shelf.
7. Support device (1, 1', 1", 1''') according to any one of the preceding claims, wherein said third portions (33) are essentially rectangular-shaped and they are arranged so as to extend along said extension line (E) of said sheet (30, 30', 30", 30''').
8. Process for manufacturing a shelf support device (1, 1', 1", 1'''), said device (1, 1', 1", 1''') comprising a mounting pin (10) adapted to be inserted in a hole obtained on a support structure and a support body (20) comprising a pair of side walls (21) defining a support surface (22) for said shelf and a rear wall (23) defining an abutment surface (24) adapted to abut against said support structure, said process comprising the following steps, to be carried out also in a different sequence or simultaneously:
 - c) arranging a flat sheet (30, 30', 30", 30''') cut to define a shape extending along a prevalent extension line (E) and comprising at least a pair of first portions (31), a pair of second portions (32), a pair of third portions (33) and at least a first connecting portion (34, 34', 34'') each continuously connected to the adjacent portions and delimitable with respect to the same through respective delimitation lines (41, 42, 43), extending transversely with respect to said extension line (E) of said flat sheet (30, 30', 30", 30''') and adapted to define corresponding bending axes (X1, X2, X3);
 - d) performing a plurality of bends around said bending axes (X1, X2, X3) in order to arrange adjacent portions on mutually orthogonal planes (P1, P2, P3, P4) so that said first portions (31) form the lateral walls (21) of said support body (20) and said second portions (32) form the rear wall (23) of said support body (20); and
 - e) plastically deforming said pair of third portions (33) so as to draw them around a cylindrical body to obtain said mounting pin (10).

9. Process for manufacturing a support device (1") according to claim 8, wherein said sheet (30") has a prevalent extension line (E) comprising at least a section having a curved course, said process comprising a step a1) wherein said second portions (31) and said first connecting portion (34") are plastically deformed to restore the straightness of the curved section of said extension line (E).
10. Process for manufacturing a support device (1") according to claim 8 or 9, wherein said first connecting portion (34") extends transversely with respect to the extension line (E) of said sheet (30") and continuously connects the lower edges (31C) of said first portions (31), said process comprising a further step d1) wherein said first connecting portion (34") is plastically deformed to obtain a lower finishing wall (26) for the support body (20) of the support device (1").
11. Process for manufacturing a support device (1'") according to claim 8, wherein said flat sheet (30'") comprises a second connecting portion (37) extending from one of the portions forming said pair of second portions (32), said process further comprising a step d2) wherein said second connecting portion (37) is plastically deformed to obtain a lower finishing wall (26) for the support body (20) of the support device (1'").

Patentansprüche

1. Regalstützvorrichtung (1, 1', 1", 1'") , die einen Montagestift (10), der angepasst ist, um in ein in einer Stützstruktur gewonnenes Loch eingesetzt zu werden, und einen Stützkörper (20) mit einem Paar Seitenwänden (21), die eine obere Stützfläche (22) für das Regal definieren, und eine Rückwand (23) umfasst, die eine Anlagefläche (24) definiert, die so angepasst ist, dass sie an der Stützstruktur anliegt, **dadurch gekennzeichnet, dass** der Montagestift (10) und der Stützkörper (20) als einzelnes Stück aus einem flachen Bogen (30, 30', 30", 30'") gewonnen werden, die sich entlang einer gängigen Erweiterungslinie (E) erstrecken und so geformt sind, dass sie wenigstens ein Paar erster Teile (31), ein Paar zweiter Teile (32), ein Paar dritter Teile (33) und wenigstens einen ersten Verbindungsteil (34, 34', 34") definieren, die jeweils mit den angrenzenden Teilen kontinuierlich verbunden sind und mit Bezug auf dieselben durch jeweilige Begrenzungslinien (41, 42, 43) abgrenzbar sind, die sich mit Bezug auf die Erweiterungslinie (E) des flachen Bogens (30, 30', 30", 30'") quer erstrecken.
2. Stützvorrichtung (1, 1', 1", 1'") nach Anspruch 1, wobei die ersten Teile (31) angepasst sind, um die Seitenwände (21) des Stützkörpers (20) zu bilden, die

zweiten Teile (32) angepasst sind, um die Rückwand (23) des Stützkörpers (20) zu bilden und die dritten Teile (33) angepasst sind, um den Montagestift (10) zu bilden.

3. Stützvorrichtung (1, 1', 1", 1'") nach einem der vorhergehenden Ansprüche, wobei die ersten Teile (31) im Wesentlichen L-förmig sind und durch einen ersten Abschnitt (31A), der sich im Wesentlichen entlang der Erweiterungslinie (E) erstreckt, und durch einen zweiten Abschnitt (31B) definiert werden, der sich mit Bezug zur Erweiterungslinie (E) quer erstreckt, wobei der erste Abschnitt (31A) und der zweite Abschnitt (31B) kontinuierlich verbunden sind.
4. Stützvorrichtung (1, 1', 1", 1'") nach einem der vorhergehenden Ansprüche, wobei die zweiten Teile (32) im Wesentlichen rechteckig geformt und sie so angeordnet sind, dass sie sich quer entlang einer Richtung quer zur Erweiterungslinie (E) erstrecken.
5. Stützvorrichtung (1, 1', 1", 1'") nach einem der vorhergehenden Ansprüche, wobei die Seitenränder (35, 35A, 35B) der zweiten Teile (32) Kopplungsprofile haben, die so geformt sind, dass sie einander durchdringen.
6. Stützvorrichtung (1, 1', 1", 1'") nach einem der vorhergehenden Ansprüche, wobei die zweiten Teile (32) jeweils eine Lasche (36) umfassen, die vom oberen Rand vorsteht und so angepasst ist, dass sie bei Verwendung der Vorrichtung zwischen der Oberfläche der Stützstruktur und einem Kopfrand des Regals angeordnet ist.
7. Stützvorrichtung (1, 1', 1", 1'") nach einem der vorhergehenden Ansprüche, wobei die dritten Teile (33) im Wesentlichen rechteckig geformt und sie so angeordnet sind, dass sie sich entlang der Erweiterungslinie (E) des Bogens (30, 30', 30", 30'") erstrecken.
8. Verfahren zur Herstellung einer Regalstützvorrichtung (1, 1', 1", 1'"), wobei die Vorrichtung (1, 1', 1", 1'") einen Montagestift (10), der angepasst ist, um in ein in einer Stützstruktur gewonnenes Loch eingesetzt zu werden, und einen Stützkörper (20) mit einem Paar Seitenwänden (21), die eine Stützfläche (22) für das Regal definieren, und eine Rückwand (23) umfasst, die eine Anlagefläche (24) definiert, die so angepasst ist, dass sie an der Stützstruktur anliegt, wobei das Verfahren die folgenden Schritte umfasst, die auch in einer anderen Reihenfolge oder gleichzeitig auszuführen sind:
- c) Anordnen eines flachen Bogens (30, 30', 30", 30'"), der so geschnitten ist, dass er eine Form

- definiert, die sich entlang einer gängigen Erweiterungslinie (E) erstreckt und wenigstens ein Paar erster Teile (31), ein Paar zweiter Teile (32), ein Paar dritter Teile (33) und wenigstens einen ersten Verbindungsteil (34, 34', 34'') umfasst, die jeweils mit den angrenzenden Teilen kontinuierlich verbunden sind und mit Bezug auf dieselben durch jeweilige Begrenzungslinien (41, 42, 43) abgrenzbar sind, die sich mit Bezug auf die Erweiterungslinie (E) des flachen Bogens (30, 30', 30'', 30''') quer erstrecken und so angepasst sind, dass sie entsprechende Biegeachsen (X1, X2, X3) definieren;
- d) Durchführen einer Vielzahl von Biegungen um die Biegeachsen (X1, X2, X3), um angrenzende Teile auf gegenseitig orthogonalen Ebenen (P1, P2, P3, P4) anzuordnen, so dass die ersten Teile (31) die Seitenwände (21) des Stützkörpers (20) bilden und die zweiten Teile (32) die Rückwand (23) des Stützkörpers (20) bilden; und
- e) plastisches Verformen des Paares dritter Teile (33), um sie um einen zylindrischen Körper zu ziehen, um den Montagestift (10) zu gewinnen.
9. Verfahren zur Herstellung einer Stützvorrichtung (1'') nach Anspruch 8, wobei der Bogen (30'') eine gängige Erweiterungslinie (E) hat, die wenigstens einen Abschnitt mit einem gekrümmten Verlauf umfasst, wobei das Verfahren einen Schritt a1) umfasst, bei dem die zweiten Teile (31) und der erste Verbindungsteil (34'') plastisch verformt werden, um die Geradheit des gekrümmten Abschnitts der Erweiterungslinie (E) wiederherzustellen.
10. Verfahren zur Herstellung einer Stützvorrichtung (1'') nach Anspruch 8 oder 9, wobei sich der erste Verbindungsteil (34'') mit Bezug auf die Erweiterungslinie (E) des Bogens (30'') quer erstreckt und die unteren Ränder (31C) der ersten Teile (31) kontinuierlich verbindet, wobei das Verfahren einen weiteren Schritt d1) umfasst, bei dem der erste Verbindungsteil (34'') plastisch verformt wird, um eine untere Abschlusswand (26) für den Stützkörper (20) der Stützvorrichtung (1'') zu gewinnen.
11. Verfahren zur Herstellung einer Stützvorrichtung (1''') nach Anspruch 8, wobei der flache Bogen (30''') einen zweiten Verbindungsteil (37) umfasst, der sich von einem der Teile erstreckt, die das Paar zweiter Teile (32) bilden, wobei das Verfahren des Weiteren einen Schritt d2) umfasst, bei dem der zweite Verbindungsteil (37) plastisch verformt wird, um eine untere Abschlusswand (26) für den Stützkörper (20) der Stützvorrichtung (1''') zu gewinnen.

Revendications

- Dispositif de support d'étagère (1, 1', 1'', 1'''), comprenant une cheville de montage (10) agencée pour être introduite dans un trou obtenu sur une structure de support et un corps de support (20) comprenant une paire de parois latérales (21) définissant une surface de support supérieure (22) pour ladite étagère et une paroi arrière (23) définissant une surface de butée (24) agencée pour venir en butée contre ladite structure de support, **caractérisé par le fait que** ladite cheville de montage (10) et ledit corps de support (20) sont obtenus sous la forme d'une seule pièce à partir d'une feuille plate (30, 30', 30'', 30'''), s'étendant le long d'une ligne d'extension prévalente (E) et mise en forme de façon à définir au moins une paire de premières parties (31), une paire de deuxièmes parties (32), une paire de troisièmes parties (33) et au moins une première partie de liaison (34, 34', 34''), chacune étant reliée de manière continue aux parties adjacentes et délimitable par rapport à celles-ci par des lignes de délimitation respectives (41, 42, 43), s'étendant transversalement par rapport à la ligne d'extension (E) de ladite feuille plate (30, 30', 30'', 30''').
- Dispositif de support (1, 1', 1'', 1''') selon la revendication 1, dans lequel lesdites premières parties (31) sont agencées pour former lesdites parois latérales (21) dudit corps de support (20), lesdites deuxièmes parties (32) sont agencées pour former ladite paroi arrière (23) dudit corps de support (20), et lesdites troisièmes parties (33) sont agencées pour former ladite cheville de montage (10).
- Dispositif de support (1, 1', 1'', 1''') selon l'une quelconque des revendications précédentes, dans lequel lesdites premières parties (31) sont essentiellement en forme de L et sont définies par un premier tronçon (31A) s'étendant essentiellement le long de ladite ligne d'extension (E) et par un second tronçon (31B) s'étendant transversalement par rapport à ladite ligne d'extension (E), ledit premier tronçon (31A) et ledit second tronçon (31B) étant reliés de manière continue.
- Dispositif de support (1, 1', 1'', 1''') selon l'une quelconque des revendications précédentes, dans lequel lesdites deuxièmes parties (32) sont essentiellement de forme rectangulaire et sont disposées de façon à s'étendre transversalement selon une direction transversale à la ligne d'extension (E).
- Dispositif de support (1, 1', 1'', 1''') selon l'une quelconque des revendications précédentes, dans lequel les bords latéraux (35, 35A, 35B) desdites deuxièmes parties (32) ont des profils d'accouplement mis en forme de façon à pénétrer les uns dans

les autres.

6. - Dispositif de support (1, 1', 1", 1''') selon l'une quelconque des revendications précédentes, dans lequel lesdites deuxièmes parties (32) comprennent chacune une languette (36) faisant saillie du bord supérieur et agencée pour être disposée, lorsque le dispositif est en utilisation, entre la surface de la structure de support et un bord de tête de l'étagère.

7. - Dispositif de support (1, 1', 1", 1''') selon l'une quelconque des revendications précédentes, dans lequel lesdites troisièmes parties (33) sont essentiellement de forme rectangulaire et sont disposées de façon à s'étendre le long de ladite ligne d'extension (E) de ladite feuille (30, 30', 30", 30''').

8. - Procédé de fabrication d'un dispositif de support d'étagère (1, 1', 1", 1'''), ledit dispositif (1, 1', 1", 1''') comprenant une cheville de montage (10) agencée pour être introduite dans un trou obtenu sur une structure de support et un corps de support (20) comprenant une paire de parois latérales (21) définissant une surface de support (22) pour ladite étagère et une paroi arrière (23) définissant une surface de butée (24) agencée pour venir en butée contre ladite structure de support, ledit procédé comprenant les étapes suivantes, qui peuvent également être mises en œuvre dans un ordre différent ou simultanément :

c) disposer une feuille plate (30, 30', 30", 30''') découpée pour définir une forme s'étendant le long d'une ligne d'extension prévalente (E) et comprenant au moins une paire de premières parties (31), une paire de deuxièmes parties (32), une paire de troisièmes parties (33) et au moins une première partie de liaison (34, 34', 34''), chacune étant reliée de manière continue aux parties adjacentes et délimitable par rapport à celles-ci par des lignes de délimitation respectives (41, 42, 43), s'étendant transversalement par rapport à ladite ligne d'extension (E) de ladite feuille plate (30, 30', 30", 30''') et agencée pour définir des axes de pliage correspondants (X1, X2, X3) ;

d) réaliser une pluralité de pliages autour desdits axes de pliage (X1, X2, X3) afin de disposer des parties adjacentes sur des plans mutuellement orthogonaux (P1, P2, P3, P4) de telle sorte que lesdites premières parties (31) forment les parois latérales (21) dudit corps de support (20) et que lesdites deuxièmes parties (32) forment la paroi arrière (23) dudit corps de support (20) ; et
e) déformer plastiquement ladite paire de troisièmes parties (33) de façon à les étirer autour d'un corps cylindrique pour obtenir ladite cheville de montage (10) .

9. - Procédé de fabrication d'un dispositif de support (1") selon la revendication 8, dans lequel ladite feuille (30") a une ligne d'extension prévalente (E) comprenant au moins un tronçon ayant un tracé courbe, ledit procédé comprenant une étape a1) dans laquelle lesdites deuxièmes parties (31) et ladite première partie de liaison (34") sont déformées plastiquement pour rétablir la rectitude du tronçon courbe de ladite ligne d'extension (E) .

10. - Procédé de fabrication d'un dispositif de support (1") selon la revendication 8 ou 9, dans lequel ladite première partie de liaison (34") s'étend transversalement par rapport à la ligne d'extension (E) de ladite feuille (30") et relie de manière continue les bords inférieurs (31C) desdites premières parties (31), ledit procédé comprenant une étape supplémentaire d1) dans laquelle ladite première partie de liaison (34") est déformée plastiquement pour obtenir une paroi de finition inférieure (26) pour le corps de support (20) du dispositif de support (1").

11. - Procédé de fabrication d'un dispositif de support (1''') selon la revendication 8, dans lequel ladite feuille plate (30''') comprend une seconde partie de liaison (37) s'étendant à partir de l'une des parties formant ladite paire de deuxièmes parties (32), ledit procédé comprenant en outre une étape d2) dans laquelle ladite seconde partie de liaison (37) est déformée plastiquement pour obtenir une paroi de finition inférieure (26) pour le corps de support (20) du dispositif de support (1''').

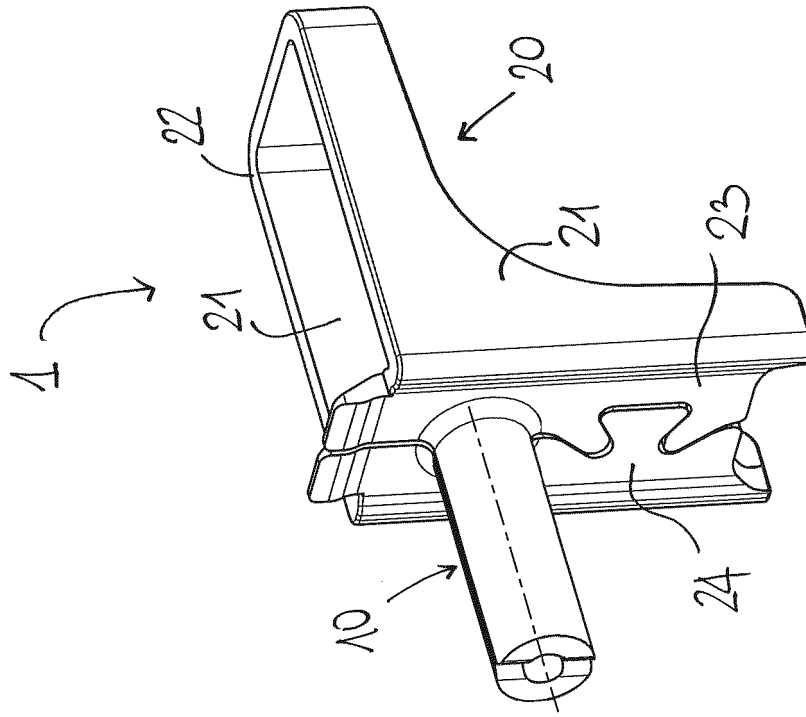

FIG. 1B

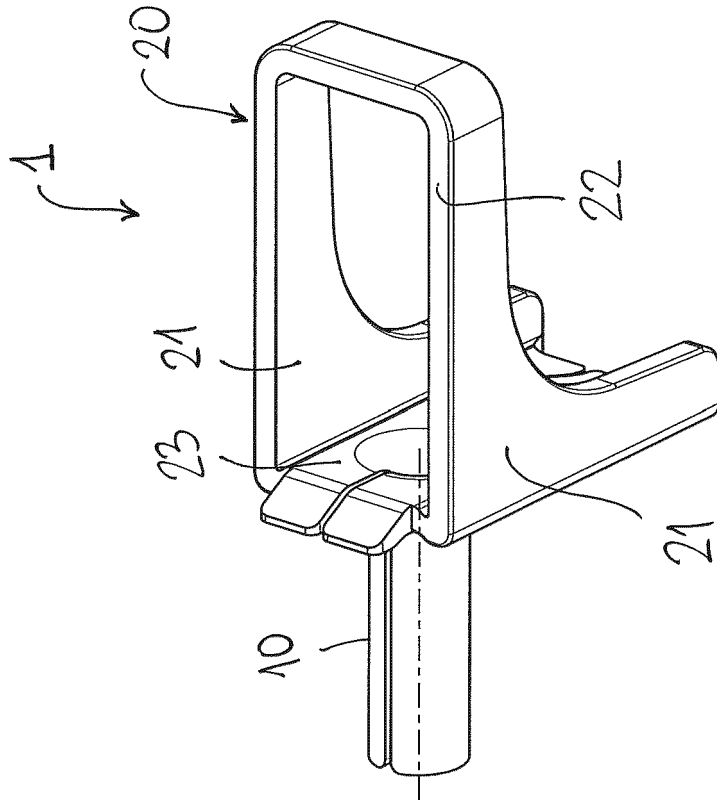

FIG. 1A

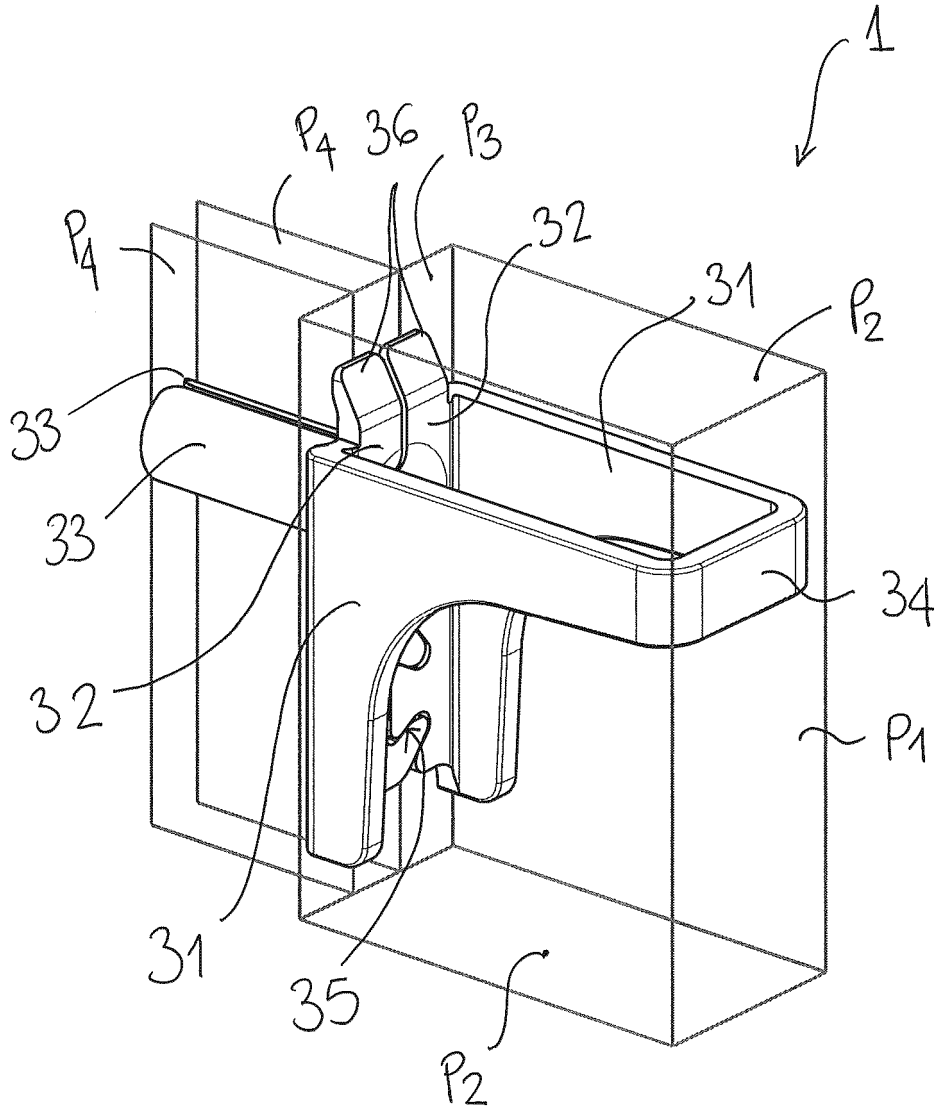

Fig. 2B

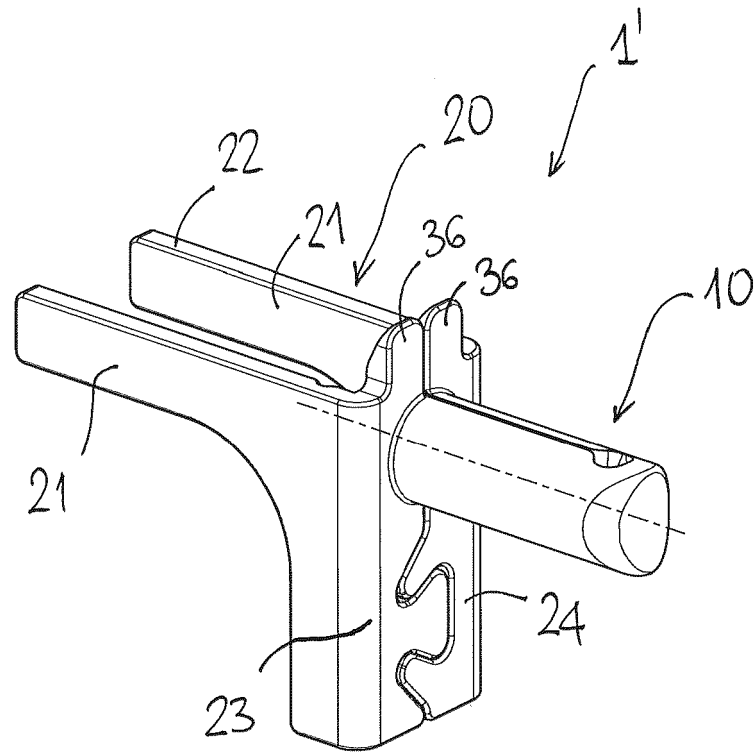

FIG. 3

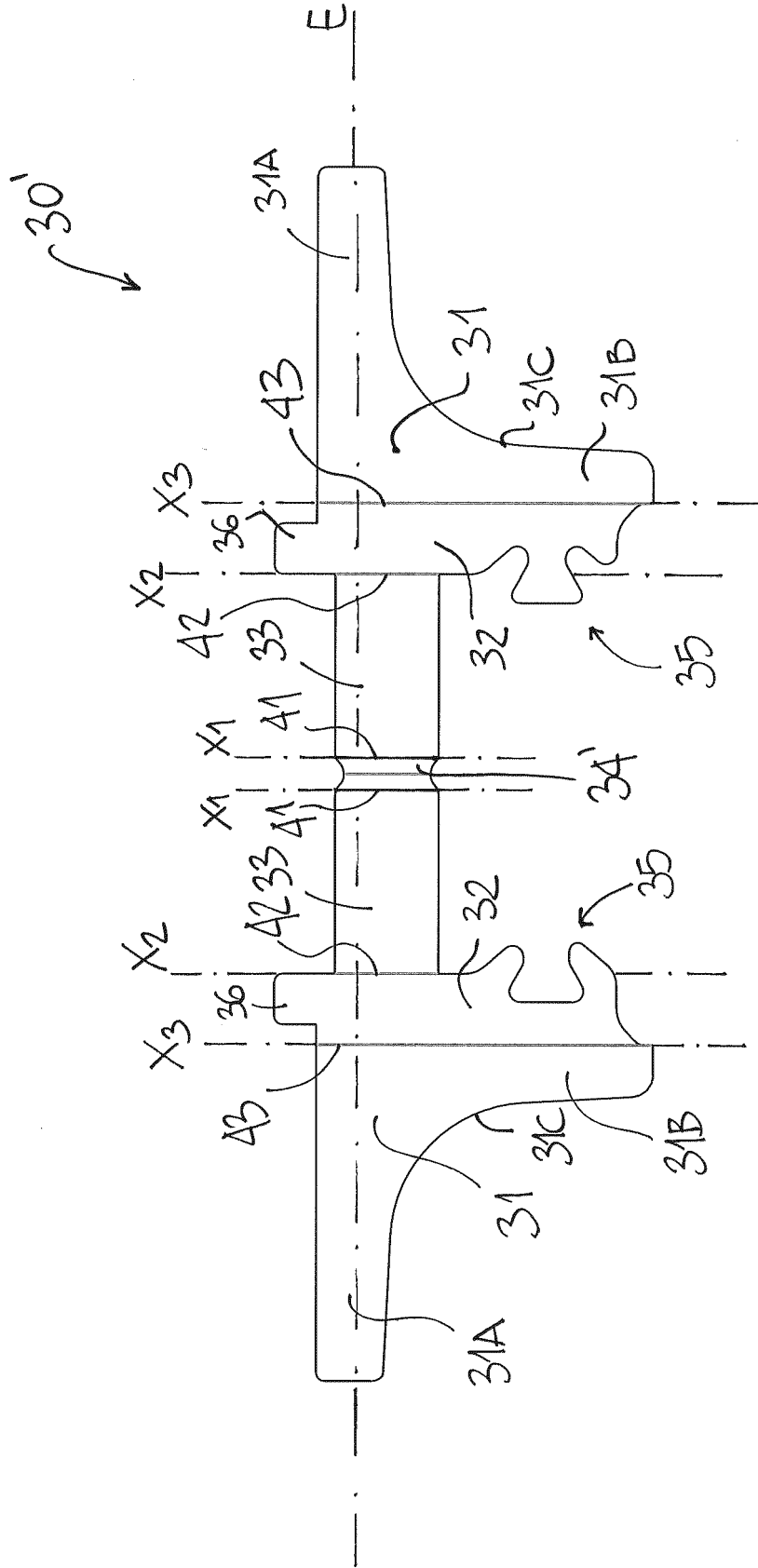

FIG. 4A

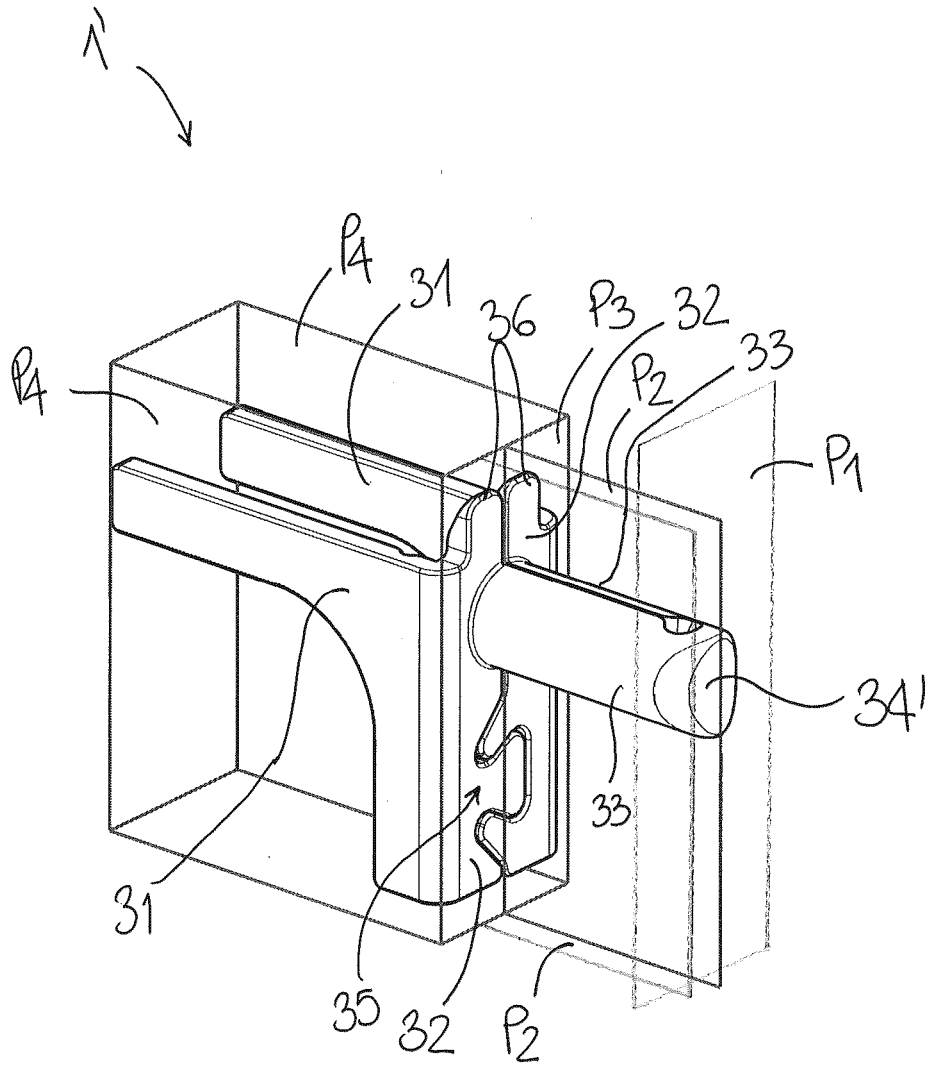

Fig. 4B

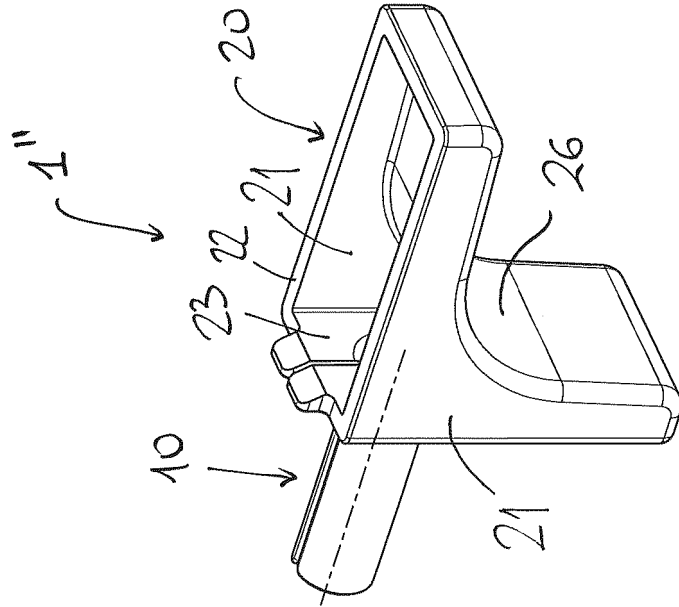

FIG. 5B

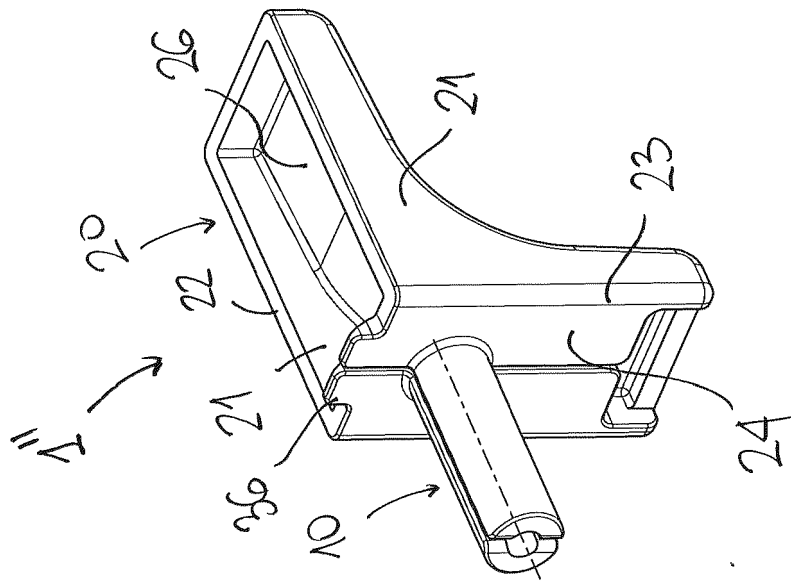

FIG. 5A

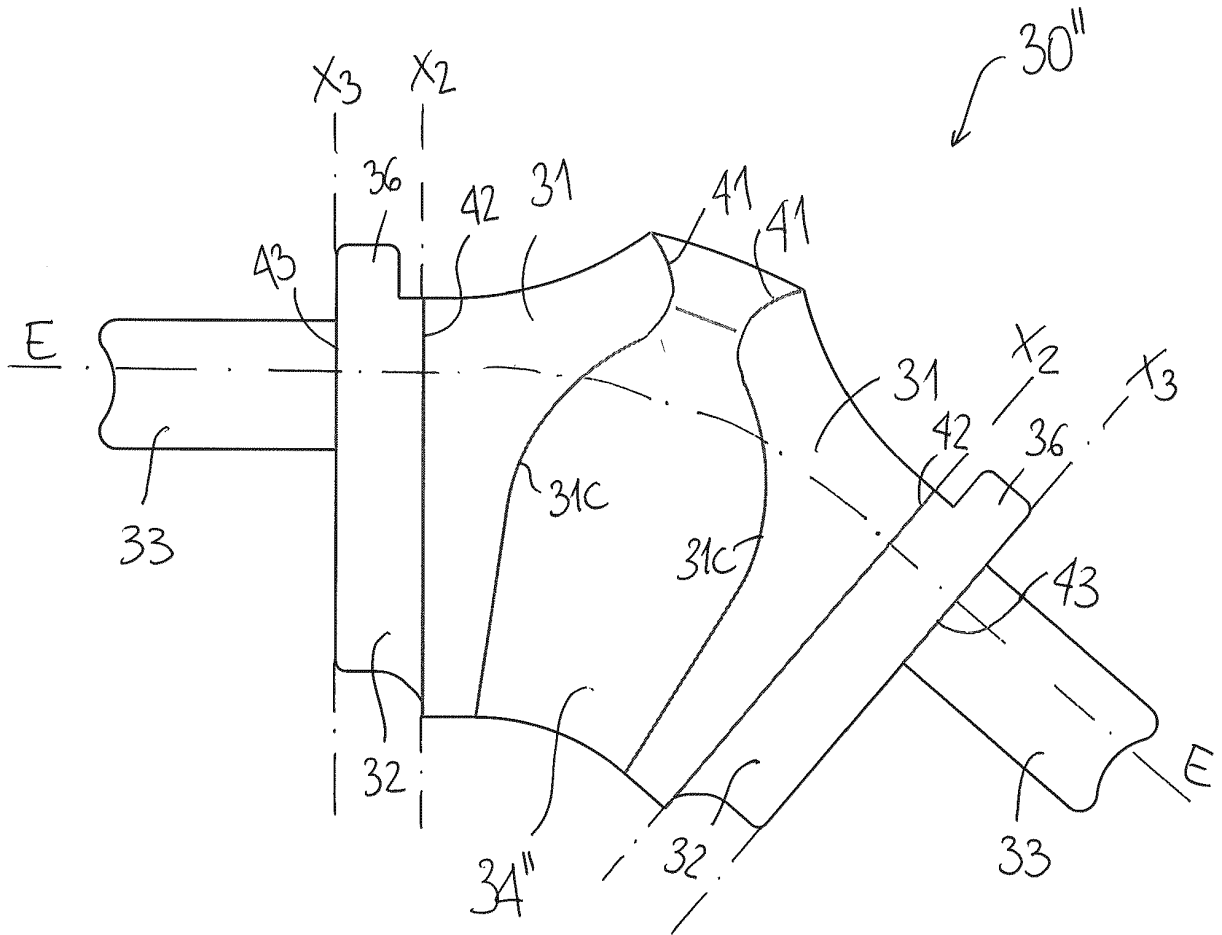

Fig. 6

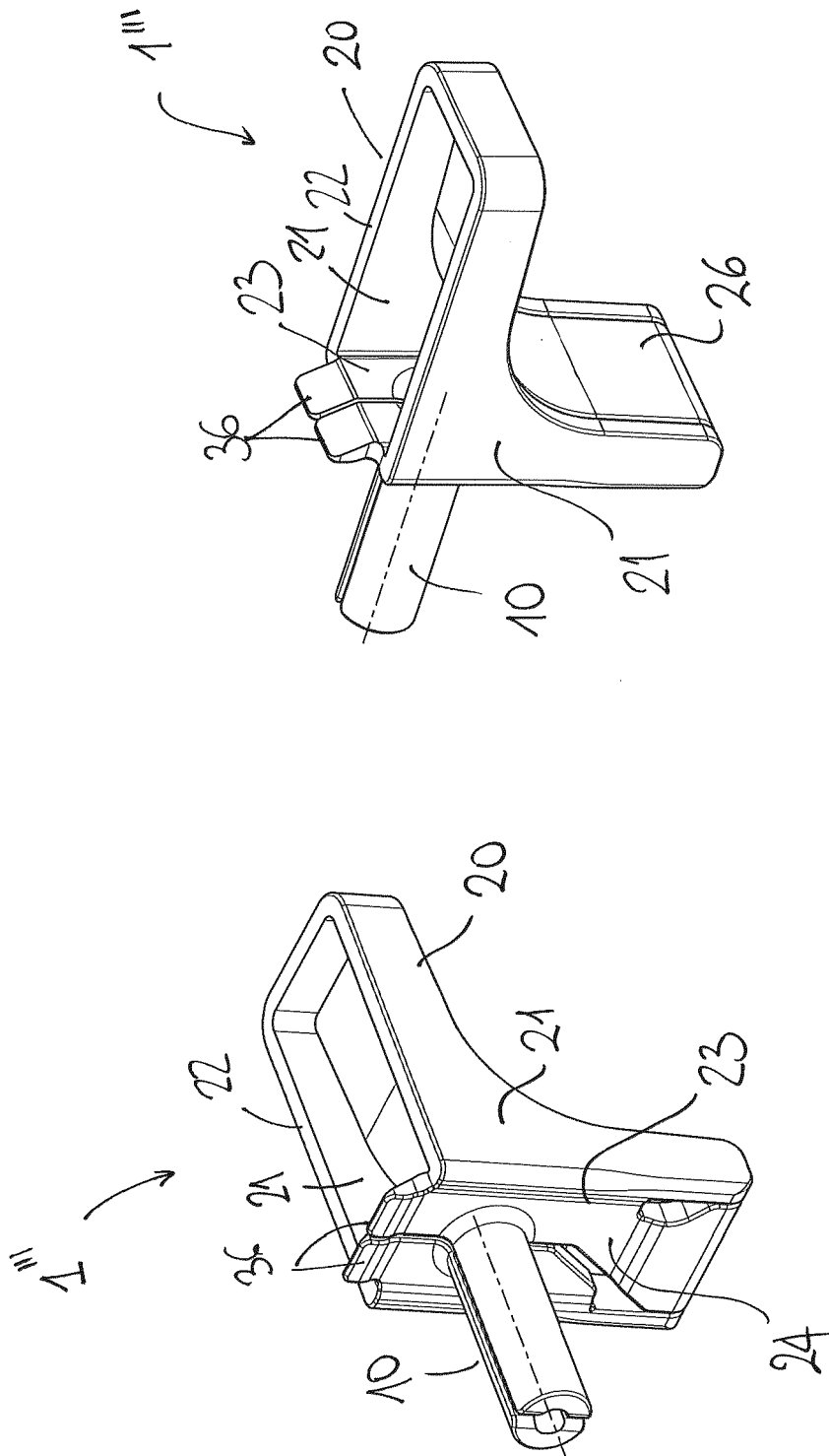

FIG. 7B

FIG. 7A

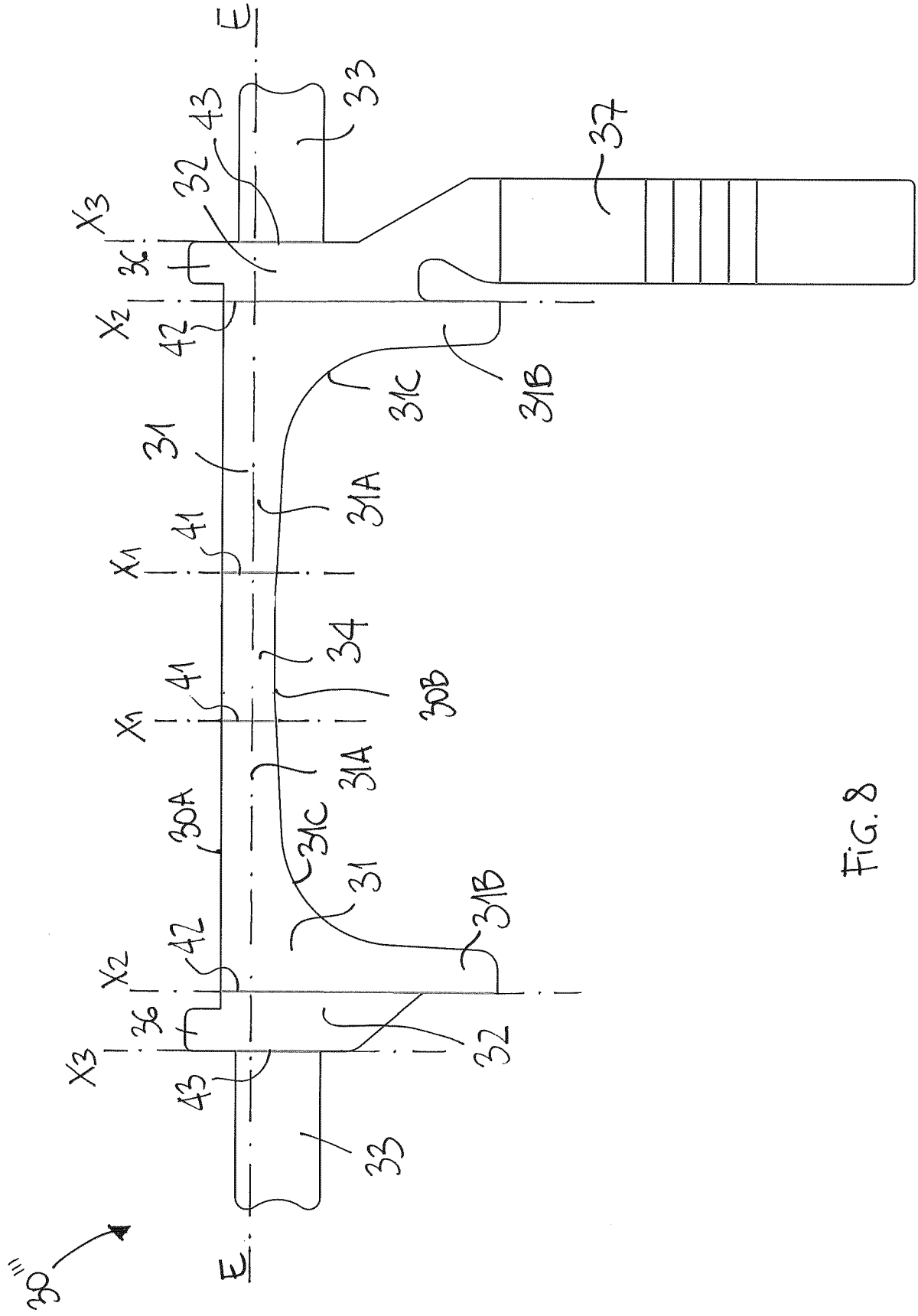

FIG. 8

REFERENCES CITED IN THE DESCRIPTION

This list of references cited by the applicant is for the reader's convenience only. It does not form part of the European patent document. Even though great care has been taken in compiling the references, errors or omissions cannot be excluded and the EPO disclaims all liability in this regard.

Patent documents cited in the description

- US 717316 A [0005]