



(11) **EP 4 212 044 A1**

(12) **EUROPEAN PATENT APPLICATION**
published in accordance with Art. 153(4) EPC

(43) Date of publication:
19.07.2023 Bulletin 2023/29

(51) International Patent Classification (IPC):
A24F 40/57 (2020.01) A24F 40/65 (2020.01)

(21) Application number: **20965989.5**

(52) Cooperative Patent Classification (CPC):
A24F 40/57; A24F 40/65

(22) Date of filing: **18.12.2020**

(86) International application number:
PCT/JP2020/047335

(87) International publication number:
WO 2022/130602 (23.06.2022 Gazette 2022/25)

(84) Designated Contracting States:
AL AT BE BG CH CY CZ DE DK EE ES FI FR GB GR HR HU IE IS IT LI LT LU LV MC MK MT NL NO PL PT RO RS SE SI SK SM TR
Designated Extension States:
BA ME
Designated Validation States:
KH MA MD TN

- **AKAO, Takeshi**
Tokyo 130-8603 (JP)
- **NAGAHAMA, Toru**
Tokyo 130-8603 (JP)
- **AOYAMA, Tatsunari**
Tokyo 130-8603 (JP)

(71) Applicant: **Japan Tobacco Inc.**
Tokyo 105-6927 (JP)

(74) Representative: **Hoffmann Eitle**
Patent- und Rechtsanwälte PartmbB
Arabellastraße 30
81925 München (DE)

(72) Inventors:
• **YAMADA, Kentaro**
Tokyo 130-8603 (JP)

(54) **INHALATION DEVICE, TERMINAL DEVICE, AND PROGRAM**

(57) [Problem] To provide a mechanism with which it is possible to improve the quality of the experience of using an inhalation device. [Solution] An inhalation device comprising: a communication unit for communicating with another device; a heating unit for generating aerosol by heating a base material containing an aerosol source; and a control unit for controlling the operation of the inhalation device on the basis of operational settings that are information for setting the operation of the inhalation device, wherein the communication unit receives correction information for correcting the operational settings according to an individual difference in the heating unit.

FIG. 9

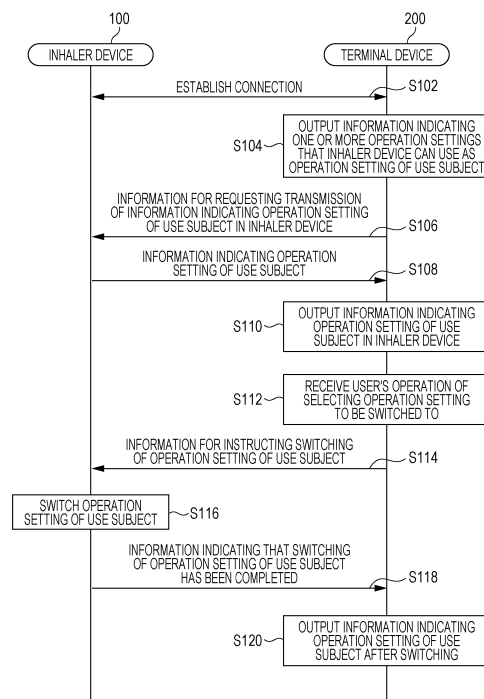

EP 4 212 044 A1

Description

Technical Field

5 **[0001]** The present invention relates to an inhaler device, a terminal device, and a program.

Background Art

10 **[0002]** Inhaler devices that generate material to be inhaled by users, such as electronic cigarettes and nebulizers, are widespread. For example, an inhaler device uses a substrate containing an aerosol source for generating an aerosol, a flavor source for imparting a flavor component to the generated aerosol, and the like, to generate the aerosol having the flavor component imparted. The user can taste a flavor by inhaling the aerosol generated by the inhaler device and having the flavor component imparted.

15 **[0003]** The quality of the flavor that the user tastes is affected by how the substrate is heated. In this regard, Patent Literature 1 below discloses a technique for switchably setting a temperature setting that defines a time-series transition of a temperature of a heating device that heats a substrate.

Citation List

20 Patent Literature

[0004] Patent Literature 1: WO 2020/019122 A1

25 Summary of Invention

Technical Problem

30 **[0005]** However, the technique disclosed in Patent Literature 1 has been developed recently, and there is room for improvement from various viewpoints.

[0006] The present invention is made in view of the above problem, and an object of the present invention is to provide a mechanism with which it is possible to further improve the quality of an experience using an inhaler device.

Solution to Problem

35 **[0007]** To address the above-described problem, an aspect of the present invention provides an inhaler device including: a communicator that communicates with another device; a heater that heats a substrate containing an aerosol source to generate an aerosol; and a controller that controls an operation of the inhaler device based on an operation setting that is information for setting the operation of the inhaler device. The communicator receives correction information for correcting the operation setting in accordance with an individual difference of the heater.

40 **[0008]** The controller may correct the operation setting based on the correction information and control an operation of the heater based on the corrected operation setting.

[0009] The operation setting may include a heating profile that defines a time-series transition of a target value for an actual measurement value measured for the heater. The controller may correct the heating profile based on the correction information and control the operation of the heater based on the corrected heating profile.

45 **[0010]** The heating profile may be divided into a plurality of heating profiles, and the communicator may receive items of information indicating the divided heating profiles at different timings.

[0011] The heating profile may be divided into the plurality of heating profiles in a time direction, and the communicator may receive the items of information indicating the divided heating profiles at the different timings.

50 **[0012]** The target value may include a plurality of target values included in the heating profiles, the correction information may include a plurality of items of correction information, and the communicator may receive the plurality of items of correction information associated with the plurality of respective target values. The controller may correct each of the plurality of target values defined in the heating profiles based on the associated correction information.

[0013] The communicator may transmit information indicating that the correction of the heating profile based on the correction information has been completed.

55 **[0014]** The communicator may transmit information indicating the individual difference of the heater.

[0015] When receiving information for requesting transmission of the information indicating the individual difference of the heater, the communicator may transmit the information indicating the individual difference of the heater.

[0016] Also, to address the above-described problem, another aspect of the present invention provides a terminal

device including: a communicator that transmits correction information for correcting an operation setting in accordance with an individual difference of a heater, the operation setting being information for setting an operation of an inhaler device, the inhaler device including the heater that heats a substrate containing an aerosol source to generate an aerosol.

5 [0017] The communicator may receive information indicating the individual difference of the heater and transmit the correction information generated based on the received information indicating the individual difference of the heater.

[0018] The communicator may transmit information for requesting transmission of the information indicating the individual difference of the heater.

10 [0019] The operation setting may include a heating profile that defines a time-series transition of a target value for an actual measurement value measured for the heater. The correction information may be used for correcting the heating profile.

[0020] The terminal device may further include: an inputter that receives an operation of selecting the operation setting to be transmitted to the inhaler device. The communicator may transmit information indicating the heating profile and the correction information, as information indicating the selected operation setting.

15 [0021] The heating profile may be divided into a plurality of heating profiles, and the communicator may transmit items of information indicating the divided heating profiles at different timings.

[0022] The heating profile may be divided into the plurality of heating profiles in a time direction, and the communicator may transmit the items of information indicating the divided heating profiles at the different timings.

20 [0023] The target value may include a plurality of target values included in the heating profiles, the correction information may include a plurality of items of correction information, and the communicator may transmit the plurality of items of correction information associated with the plurality of respective target values.

[0024] The communicator may receive information indicating that the correction of the heating profile based on the correction information in the inhaler device has been completed.

25 [0025] The terminal device may further include: an outputter that outputs information. The outputter may output, when the communicator has received the information indicating that the correction of the heating profile based on the correction information in the inhaler device has been completed, the information indicating that the correction of the heating profile based on the correction information in the inhaler device has been completed.

30 [0026] Also, to address the above-described problem, still another aspect of the present invention provides a program that causes a computer to execute: controlling a terminal device to transmit correction information for correcting an operation setting in accordance with an individual difference of a heater, the operation setting being information for setting an operation of an inhaler device, the inhaler device including the heater that heats a substrate containing an aerosol source to generate an aerosol.

Advantageous Effects of Invention

35 [0027] As described above, according to the present invention, the mechanism with which it is possible to further improve the quality of the experience using the inhaler device is provided.

Brief Description of Drawings

40 [0028]

[Fig. 1] Fig. 1 is a schematic diagram of the inhaler device according to the internal configuration example.

[Fig. 2] Fig. 2 is an overall perspective view of the inhaler device according to the present embodiment.

45 [Fig. 3] Fig. 3 is an overall perspective view of the inhaler device according to the present embodiment in a state in which a stick substrate is held.

[Fig. 4] Fig. 4 is a diagram illustrating an example of a configuration of a system according to the present embodiment.

[Fig. 5] Fig. 5 is a graph presenting an example of a time-series transition of an actual temperature of a heater operated based on a heating profile presented in Table 1.

50 [Fig. 6] Fig. 6 is a diagram illustrating an example of a display screen displayed by a terminal device according to the present embodiment.

[Fig. 7] Fig. 7 is a diagram illustrating an example of a display screen displayed by the terminal device according to the present embodiment.

[Fig. 8] Fig. 8 is a diagram illustrating an example of a display screen displayed by the terminal device according to the present embodiment.

55 [Fig. 9] Fig. 9 is a sequence diagram presenting an example of a flow of switching processing for an operation setting of a use subject executed in the system according to the present embodiment.

[Fig. 10] Fig. 10 is a diagram illustrating an example of a display screen displayed by the terminal device according to the present embodiment.

[Fig. 11] Fig. 11 is a diagram illustrating an example of a display screen displayed by the terminal device according to the present embodiment.

[Fig. 12] Fig. 12 is a sequence diagram presenting an example of a flow of download processing for an operation setting executed in the system according to the present embodiment.

5

Description of Embodiments

[0029] Hereinafter, preferred embodiments of the present invention will be described in detail with reference to the accompanying drawings. In this description and the drawings, structural elements having substantially the same functional configuration are denoted by the same reference numeral, and redundant description thereof will be omitted.

10

1. Configuration example of inhaler device

[0030] An inhaler device generates material to be inhaled by a user. In the example described below, the material generated by the inhaler device is an aerosol. Alternatively, the material generated by the inhaler device may be gas.

15

(1) Internal configuration example

[0031] Fig. 1 is a schematic diagram of the inhaler device according to the internal configuration example. As illustrated in Fig. 1, an inhaler device 100 according to the present configuration example includes a power supply 111, a sensor 112, a notifier 113, a memory 114, a communicator 115, a controller 116, a heater 121, a holder 140, and a heat insulator 144.

20

[0032] The power supply 111 stores electric power. The power supply 111 supplies electric power to the structural elements of the inhaler device 100 under the control of the controller 116. The power supply 111 may be a rechargeable battery such as a lithium ion secondary battery.

25

[0033] The sensor 112 acquires various items of information regarding the inhaler device 100. In an example, the sensor 112 may be a pressure sensor such as a microphone condenser, a flow sensor, or a temperature sensor, and acquire a value generated in accordance with the user's inhalation. In another example, the sensor 112 may be an input device that receives information input by the user, such as a button or a switch.

30

[0034] The notifier 113 provides information to the user. The notifier 113 may be a light-emitting device that emits light, a display device that displays an image, a sound output device that outputs sound, or a vibration device that vibrates.

[0035] The memory 114 stores various items of information for operation of the inhaler device 100. The memory 114 may be a non-volatile storage medium such as flash memory.

[0036] The communicator 115 is a communication interface capable of communication in conformity with any wired or wireless communication standard. Such a communication standard may be, for example, Wi-Fi (registered trademark) or Bluetooth (registered trademark).

35

[0037] The controller 116 functions as an arithmetic processing unit and a control circuit, and controls the overall operations of the inhaler device 100 in accordance with various programs. The controller 116 includes an electronic circuit such as a central processing unit (CPU) and a microprocessor, for example.

40

[0038] The holder 140 has an internal space 141, and holds a stick substrate 150 in a manner partially accommodated in the internal space 141. The holder 140 has an opening 142 that allows the internal space 141 to communicate with outside. The holder 140 holds the stick substrate 150 that is inserted into the internal space 141 through the opening 142. For example, the holder 140 may be a tubular body having the opening 142 and a bottom 143 on its ends, and may define the pillar-shaped internal space 141. The holder 140 also has a function of defining a flow path of air supplied to the stick substrate 150. For example, the bottom 143 has an air inlet hole that is an inlet of air into the flow path. On the other hand, an air outlet hole which is an outlet of the air from the flow path is the opening 142.

45

[0039] The stick substrate 150 includes a substrate 151 and an inhalation port 152. The substrate 151 includes an aerosol source. In this configuration example, the aerosol source is not limited to a liquid, but may be a solid. The stick substrate 150 held by the holder 140 includes the substrate 151 at least partially accommodated in the internal space 141 and the inhalation port 152 at least partially protruding from the opening 142. When the user inhales with the inhalation port 152 protruding from the opening 142 in his/her mouth, air flows into the internal space 141 from the air inlet hole (not illustrated), and the air and an aerosol generated from the substrate 151 reach inside the mouth of the user.

50

[0040] The heater 121 heats the aerosol source to atomize the aerosol source and generate the aerosol. In the example illustrated in Fig. 1, the heater 121 has a film-like shape and surrounds the outer circumference of the holder 140. Subsequently, heat produced from the heater 121 heats the substrate 151 of the stick substrate 150 from the outer circumference, generating the aerosol. The heater 121 produces heat when receiving electric power from the power supply 111. In an example, the electric power may be supplied in response to the sensor 112 detecting a start of the user's inhalation and/or an input of predetermined information. Subsequently, the supply of the electric power may be

55

stopped in response to the sensor 112 detecting an end of the user's inhalation and/or an input of predetermined information.

[0041] The heat insulator 144 prevents heat from transferring from the heater 121 to the other structural elements. For example, the heat insulator 144 may be a vacuum heat insulator or an aerogel heat insulator.

[0042] The configuration example of the inhaler device 100 has been described above. The inhaler device 100 is not limited to the above configuration, and may be configured in various ways as exemplified below.

[0043] In an example, the heater 121 may have a blade-like shape, and may be disposed so that the heater 121 protrudes from the bottom 143 of the holder 140 toward the internal space 141. In this case, the heater 121 having the blade-like shape is inserted into the substrate 151 of the stick substrate 150 and heats the substrate 151 of the stick substrate 150 from its inside. In another example, the heater 121 may be disposed so that the heater 121 covers the bottom 143 of the holder 140. In still another example, the heater 121 may be implemented as a combination of two or more selected from a first heater that covers the outer circumference of the holder 140, a second heater having the blade-like shape, and a third heater that covers the bottom 143 of the holder 140.

[0044] In another example, the holder 140 may include an opening/closing mechanism that at least partially opens and closes an outer shell defining the internal space 141. Examples of the opening/closing mechanism include a hinge. In addition, the holder 140 may hold the stick substrate 150 while sandwiching the stick substrate 150 inserted into the internal space 141 by opening and closing the outer shell. In this case, the heater 121 may be at the sandwiching position of the holder 140 and may produce heat while pressing the stick substrate 150.

[0045] In addition, means for atomizing the aerosol source is not limited to heating by the heater 121. For example, the means for atomizing the aerosol source may be induction heating.

(2) Configuration example of appearance

[0046] Fig. 2 is an overall perspective view of the inhaler device 100 according to the present embodiment. Fig. 3 is an overall perspective view of the inhaler device according to the present embodiment in a state in which the stick substrate 150 is held.

[0047] As illustrated in Figs. 2 and 3, the inhaler device 100 includes a top housing 11A, a bottom housing 11B, a cover 12, a switch 13, a lid 14, a vent 15, and a cap 16. The top housing 11A and the bottom housing 11B are connected to each other to define an outermost outer housing 11 of the inhaler device 100. The outer housing 11 has a size to fit in a hand of the user. When the user uses the inhaler device 100, the user can hold the inhaler device 100 with his/her hand and inhale a flavor.

[0048] The top housing 11A has an opening (not illustrated), and the cover 12 is coupled to the top housing 11A so as to close the opening. As illustrated in Fig. 3, the cover 12 has the opening 142 into which the stick substrate 150 can be inserted. The lid 14 is configured to open and close the opening 142 of the cover 12. Specifically, the lid 14 is attached to the cover 12 and is configured to be movable along a surface of the cover 12 between a first position at which the lid 14 closes the opening 142 and a second position at which the lid 14 opens the opening 142. Accordingly, the lid 14 can permit or restrict an access of the stick substrate 150 to the inside (the internal space 141 illustrated in Fig. 1) of the inhaler device 100. A state in which the lid 14 is located at the second position and the lid 14 opens the opening 142 is hereinafter also referred to as an open state. A state in which the lid 14 is located at the first position and the lid 14 closes the opening 142 is hereinafter also referred to as a closed state.

[0049] The switch 13 is used to switch ON and OFF the operation of the inhaler device 100. For example, when the user operates the switch 13 in a state in which the stick substrate 150 is inserted into the internal space 141 through the opening 142 as illustrated in Fig. 3, electric power is supplied from the power supply 111 to the heater 121, and the stick substrate 150 can be heated without being combusted. When the stick substrate 150 is heated, an aerosol is generated from the aerosol source contained in the stick substrate 150, and a flavor of a flavor source is taken into the aerosol. The user can inhale the aerosol containing the flavor by inhaling a portion (a portion illustrated in Fig. 3, that is, the inhalation port 152) of the stick substrate 150 protruding from the inhaler device 100.

[0050] The vent 15 is for introducing air into the internal space 141. The air taken into the inside of the inhaler device 100 from the vent 15 is introduced into the internal space 141 from, for example, an air inlet hole formed in the bottom 143 of the holder 140. The cap 16 is configured to be detachably attached to the bottom housing 11B. When the cap 16 is attached to the bottom housing 11B, the vent 15 is formed between the bottom housing 11B and the cap 16. The cap 16 may have, for example, a through hole, a notch, or the like (not illustrated). In the present description, the longitudinal direction of the inhaler device 100 refers to a direction in which the stick substrate 150 is inserted into the opening 142. Also, in the inhaler device 100 of the present description, a side where a fluid such as air flows in (for example, the vent 15 side) is referred to as an upstream side, and a side where the fluid flows out (for example, the opening 142 side) is referred to as a downstream side.

2. Technical features

(1) Configuration example of system

5 **[0051]** Fig. 4 is a diagram illustrating an example of a configuration of a system 1 according to the present embodiment. As illustrated in Fig. 4, the system 1 includes the inhaler device 100 and a terminal device 200.

- Configuration of inhaler device 100

10 **[0052]** The configuration of the inhaler device 100 is as described above. Hereinafter, user's inhalation of an aerosol generated by the inhaler device 100 is also simply referred to as "inhalation" or "puff". An action of the user's inhalation is hereinafter also referred to as a puff action.

[0053] The inhaler device 100 according to the present embodiment generates an aerosol to be inhaled by a user using a substrate containing an aerosol source. The heater 121 heats the substrate containing the aerosol source to generate the aerosol. The stick substrate 150 is an example of the substrate in the present embodiment.

- Configuration of terminal device 200

20 **[0054]** The terminal device 200 is used by the user of the inhaler device 100. For example, the terminal device 200 is constituted by any information processing device, such as a smartphone, a tablet terminal, or a wearable device. As illustrated in Fig. 4, the terminal device 200 includes an inputter 210, an outputter 220, a communicator 230, a memory 240, and a controller 250.

[0055] The inputter 210 has a function of receiving an input of various items of information. The inputter 210 may include an input device that receives an input of information from the user. Examples of the input device include a button, a keyboard, a touch panel, and a microphone. In addition, the inputter 210 may include various sensors such as an image sensor.

30 **[0056]** The outputter 220 has a function of outputting information. The outputter 220 may include an output device that outputs information to the user. Examples of the output device include a display device that displays information, a light-emitting device that emits light, a vibration device that vibrates, and a sound output device that outputs sound. An example of the display device is a display. An example of the light-emitting device is a light emitting diode (LED). An example of the vibration device is an eccentric motor. An example of the sound output device is a speaker. The outputter 220 outputs information input from the controller 250 to notify the user of the information.

35 **[0057]** The communicator 230 is a communication interface for transmitting and receiving information between the terminal device 200 and another device. The communicator 230 performs communication in conformity with any wired or wireless communication standard. Such a communication standard may be, for example, wireless local area network (LAN), wired LAN, Wi-Fi (registered trademark), or Bluetooth (registered trademark).

[0058] The memory 240 stores various items of information for operation of the terminal device 200. The memory 240 may be a non-volatile storage medium such as flash memory.

40 **[0059]** The controller 250 functions as an arithmetic processing unit or a control circuit, and controls the overall operations of the terminal device 200 in accordance with various programs. The controller 250 includes an electronic circuit, such as a central processing unit (CPU) or a microprocessor, for example. In addition, the controller 250 may include a read only memory (ROM) that stores a program to be used, calculation parameters, and the like, and a random access memory (RAM) that temporarily stores parameters that change as appropriate. The terminal device 200 executes various processing under the control of the controller 250. Examples of the processing controlled by the controller 250 include processing of information input by the inputter 210, an output of information by the outputter 220, transmission and reception of information by the communicator 230, and storage and reading of information by the memory 240. The controller 250 also controls other processing executed by the terminal device 200, such as an input of information to each structural element and processing based on information output from each structural element.

45 **[0060]** Note that the function of the controller 250 may be implemented using an application. The application may be preinstalled or may be downloaded. Alternatively, the function of the controller 250 may be implemented by progressive web apps (PWA).

- Inter-device communication

55 **[0061]** The inhaler device 100 can communicate with another device. Communication between the inhaler device 100 and another device may use a wireless or wired communication link. In the present description, the communication link is described as a wireless communication link.

[0062] In particular, the inhaler device 100 establishes connection with the other paired device to transmit and receive

information. Pairing is processing in which two devices exchange information with each other and store the information. Examples of the information to be exchanged include identification information of a partner such as a service set identifier (SSID), and information related to an encryption key used for encrypting information to be transmitted and received.

5 [0063] The inhaler device 100 and the terminal device 200 first perform pairing and then transmit and receive information. It is desirable that a wireless communication standard used for wireless communication between the inhaler device 100 and the terminal device 200 is a short-range wireless communication standard such as Bluetooth. In this case, when the inhaler device 100 and the terminal device 200 are located within a range in which the short-range wireless communication is possible, the inhaler device 100 and the terminal device 200 can establish connection and communicate with each other. In the following description, it is assumed that the inhaler device 100 and the terminal device 200 perform communication in conformity with Bluetooth Low Energy (BLE, registered trademark).

10 [0064] The connection between the inhaler device 100 and the terminal device 200 may be established when a predetermined condition is satisfied. An example of the predetermined condition is that the state of the lid 14 has changed to the open state. Another example of the predetermined condition is that charging of the power supply 111 has started. When the inhaler device 100 is connected to an external power supply via, for example, a Universal Serial Bus (USB) or the like, the inhaler device 100 starts charging the power supply 111. When any of these predetermined conditions is satisfied, the inhaler device 100 starts transmission of an advertisement, establishes connection with the terminal device 200 that has received the advertisement, and starts transmission and reception of information.

15 [0065] The connection between the inhaler device 100 and the terminal device 200 may be disconnected when a predetermined condition is satisfied. An example of the predetermined condition is that the state of the lid 14 has changed to the closed state. Another example of the predetermined condition is that charging of the power supply 111 has ended. For example, when the connection with the external power supply is released, the inhaler device 100 ends the charging of the power supply 111. For example, when any of these predetermined conditions is satisfied, and when an operation by the user is not detected for a predetermined time or more and information is not transmitted or received, the inhaler device 100 disconnects the connection with the terminal device 200.

25 (2) Operation setting

[0066] The inhaler device 100 operates based on an operation setting. The operation setting is information for setting the operation of the inhaler device 100. The inhaler device 100 may store one or more operation settings. Among the one or more operation settings stored in the inhaler device 100, an operation setting that is used by the inhaler device 100 is also referred to as an operation setting of a use subject. That is, the inhaler device 100 operates based on the operation setting of the use subject. More specifically, the controller 116 controls the operation of each structural element of the inhaler device 100 including the heater 121 based on the operation setting of the use subject. An example of the operation setting will be described below.

35 (2.1) Heating profile

[0067] The operation setting may include a heating profile. The controller 116 controls the operation of the heater 121 based on the heating profile. The heating profile is information indicating a time-series transition of a target value for a value measured for the heater 121 (hereinafter, also referred to as an actual measurement value). The controller 116 controls the operation of the heater 121 so that a time-series transition of an actual measurement value measured for the heater 121 becomes similar to the time-series transition of the target value defined in the heating profile. Accordingly, an aerosol is generated as planned in the heating profile. The heating profile is typically designed to optimize the flavor that the user tastes when the user inhales the aerosol generated from the stick substrate 150. Thus, by controlling the operation of the heater 121 based on the heating profile, it is possible to optimize the flavor that the user tastes.

- Heating profile related to temperature

40 [0068] The actual measurement value may be the temperature of the heater 121. In this case, the heating profile is information that defines a time-series transition of a target temperature that is a target value for the temperature of the heater 121. The controller 116 controls the temperature of the heater 121 so that a time-series transition of an actually measured temperature (hereinafter, also referred to as an actual temperature) of the heater 121 becomes similar to the time-series transition of the target temperature defined in the heating profile. As a result, it is possible to optimize the flavor that the user tastes.

45 [0069] The heating profile includes one or more combinations of an elapsed time since a start of heating and a target temperature to be reached within the elapsed time. Then, the controller 116 controls the temperature of the heater 121 based on the difference between the current actual temperature and the target temperature in the heating profile corresponding to the elapsed time since the start of the current heating. The control on the temperature of the heater 121

can be implemented by, for example, known feedback control. Specifically, the controller 116 causes the electric power from the power supply 111 to be supplied to the heater 121 in the form of a pulse by pulse width modulation (PWM) or pulse frequency modulation (PFM). In this case, the controller 116 can control the temperature of the heater 121 by adjusting the duty ratio of the electric power pulse.

5 [0070] In the feedback control, the controller 116 may control the electric power supplied to the heater 121, for example, the above-described duty ratio, based on the difference or the like between the actual temperature and the target temperature. The feedback control may be, for example, a proportional-integral-differential controller (PID controller). Alternatively, the controller 116 may perform simple ON-OFF control. For example, the controller 116 may execute heating by the heater 121 until the actual temperature reaches the target temperature, stop heating by the heater 121 when the actual temperature has reached the target temperature, and execute heating again by the heater 121 when the actual temperature becomes lower than the target temperature.

10 [0071] The temperature of the heater 121 can be quantified by, for example, measuring or estimating a resistance value (more accurately, an electrical resistance value) of the heater 121 (more accurately, a heat producing resistor constituting the heater 121). This is because the resistance value of the heat producing resistor changes with the temperature. The resistance value of the heat producing resistor can be estimated, for example, by measuring the amount of voltage drop in the heat producing resistor. The amount of voltage drop in the heat producing resistor can be measured by a voltage sensor that measures the potential difference applied to the heat producing resistor. In another example, the temperature of the heater 121 can be measured by a temperature sensor installed near the heater 121.

15 [0072] A time section from the start to the end of processing of generating an aerosol using the stick substrate 150, more specifically, a time section during which the heater 121 operates based on the heating profile is hereinafter also referred to as a heating session. The start of the heating session is a timing at which heating based on the heating profile is started. The end of the heating session is a timing at which a sufficient amount of aerosol is no longer generated. The heating session consists of a preheating period in the former half and a puffable period in the latter half. The puffable period is a period during which a sufficient amount of aerosol is expected to be generated. The preheating period is a period from the start of heating to the start of the puffable period. The heating performed during the preheating period is also referred to as preheating.

20 [0073] An example of the heating profile is presented in Table 1 below.

[Table 1]

30 [0074]

Table 1. Example of heating profile

Time section	Elapsed time since start of heating	Target temperature
Initial temperature rise section	25 seconds	295°C
	35 seconds	295°C
Intermediate temperature drop section	45 seconds	230°C
Temperature re-rise section	180 seconds	230°C
	260 seconds	260°C
	355 seconds	260°C
Heating end section	Later	-

35 [0075] The time-series transition of the actual temperature of the heater 121 when the controller 116 controls the operation of the heater 121 in accordance with the heating profile presented in Table 1 will be described with reference to Fig. 5. Fig. 5 is a graph presenting an example of the time-series transition of the actual temperature of the heater 121 operated based on the heating profile presented in Table 1. The horizontal axis of this graph indicates time (second). The vertical axis of this graph indicates the temperature of the heater 121. A line 21 in this graph indicates a time-series transition of the actual temperature of the heater 121. Also, points 22 (22A to 22F) in this graph indicate target temperatures defined in the heating profile. As presented in Fig. 5, the actual temperature of the heater 121 changes in a manner similar to the time-series transition of the target temperature defined in the heating profile.

40 [0076] As presented in Table 1, the heating profile first includes an initial temperature rise section. The initial temperature rise section is a time section included at the beginning of the heating profile and is a section in which the target temperature set at the end is higher than an initial temperature. The initial temperature is a temperature expected as the temperature of the heater 121 before the start of heating. An example of the initial temperature is any temperature such as 0°C.

Another example of the initial temperature is a temperature corresponding to the atmospheric temperature. As presented in Fig. 5, in accordance with the target temperature set in the initial temperature rise section, the actual temperature of the heater 121 reaches 295°C 25 seconds after the start of heating and is maintained at 295°C until 35 seconds after the start of heating. Accordingly, it is expected that the temperature of the stick substrate 150 reaches a temperature at which a sufficient amount of aerosol is generated. By raising the temperature to 295°C at a stroke immediately after the start of heating, it is possible to end the preheating early and start the puffable period early. Although Fig. 5 presents an example in which the initial temperature rise section and the preheating period coincide with each other, the initial temperature rise section and the preheating period may be different from each other.

[0077] As presented in Table 1, the heating profile then includes an intermediate temperature drop section. The intermediate temperature drop section is a time section after the initial temperature rise section and is a time section in which the target temperature set at the end is lower than the target temperature set at the end of the initial temperature rise section. As presented in Fig. 5, the actual temperature of the heater 121 drops from 295°C to 230°C from 35 seconds to 45 seconds after the start of heating in accordance with the target temperature set in the intermediate temperature drop section. In such a section, supply of electric power to the heater 121 may be stopped. Even in this case, a sufficient amount of aerosol is generated by the remaining heat of the heater 121 and the stick substrate 150. Here, when the heater 121 is maintained at a high temperature, the aerosol source contained in the stick substrate 150 is rapidly consumed, and there may be an inconvenience that the flavor that the user tastes is too strong. In this regard, it is possible to avoid such an inconvenience and improve the quality of a user's puff experience by providing the intermediate temperature drop section in the middle.

[0078] As presented in Table 1, the heating profile then includes a temperature re-rise section. The temperature re-rise section is a time section after the intermediate temperature drop section and is a time section in which the target temperature set at the end is higher than the target temperature set at the end of the intermediate temperature drop section. As presented in Fig. 5, the actual temperature of the heater 121 rises stepwise from 230°C to 260°C from 45 seconds to 355 seconds after the start of heating in accordance with the target temperature set in the temperature re-rise section. When the temperature of the heater 121 is continuously decreased, the temperature of the stick substrate 150 is also decreased. Thus, the generation amount of aerosol may be decreased, and the flavor that the user tastes may be deteriorated. In this regard, by raising the temperature again after decreasing the temperature, it is possible to prevent a deterioration of the flavor that the user tastes even in the latter half of the heating session.

[0079] As presented in Table 1, the heating profile includes a heating end section at the end. The heating end section is a time section after the temperature re-rise section and is a time section in which heating is not performed. The target temperature does not have to be set. As presented in Fig. 5, the actual temperature of the heater 121 drops 355 seconds after the start of heating. Supply of electric power to the heater 121 may be ended 355 seconds after the start of heating. Even in this case, a sufficient amount of aerosol is generated by the remaining heat of the heater 121 and the stick substrate 150 for a while. In the example presented in Fig. 5, the puffable period, that is, the heating session ends 365 seconds after the start of heating.

[0080] The user may be notified of a timing at which the puffable period starts and a timing at which the puffable period ends. Further, the user may be notified of a timing a predetermined time before the end of the puffable period (for example, a timing at which supply of electric power to the heater 121 ends). In this case, the user can puff in the puffable period with reference to the notification.

- Heating profile related to resistance value

[0081] The actual measurement value may be a resistance value of the heater 121. This point will be described below.

[0082] As described above, when the resistance value of the heater 121 changes with the temperature of the heater 121, it can be said that the temperature of the heater 121 is synonymous with the resistance value of the heater 121. Thus, the target temperature of the heater 121 can also be indicated by the resistance value of the heater 121. That is, a parameter in the heating profile may be the resistance value of the heater 121 corresponding to the target temperature. In this case, the heating profile is information that defines a time-series transition of a target resistance value that is a target value for the resistance value of the heater 121. The inhaler device 100 controls the resistance value of the heater 121 so that a time-series transition of an actual resistance value of the heater 121 becomes similar to the time-series transition of the target resistance value defined in the heating profile. The control on the resistance value of the heater 121 can be implemented by, for example, known feedback control. Specifically, the controller 116 causes the electric power from the power supply 111 to be supplied to the heater 121 in the form of a pulse by pulse width modulation (PWM) or pulse frequency modulation (PFM). In this case, the controller 116 can control the resistance value of the heater 121 by adjusting the duty ratio of the electric power pulse. With this configuration, it is possible to cause the actual temperature of the heater 121 to transition in a manner similar to the case where the heating profile defines the time-series transition of the target temperature.

[0083] Although the temperature of the heater 121 has a correspondence relation to the resistance value of the heater

121, the resistance value corresponding to the temperature of the heater 121 depends on the characteristics of the heater 121 and the environmental temperature. Thus, when the characteristics of the heater 121 or the environmental temperature is different, even though the target temperature is the same, the target resistance value having a correspondence relation to the target temperature becomes a different value.

5 **[0084]** Hereinafter, an example in which the actual measurement value is the resistance value of the heater 121 and the target value in the heating profile is the target resistance value will be mainly described.

(2.2) High-temperature protection threshold

10 **[0085]** The operation setting may include a high-temperature protection threshold. The high-temperature protection threshold is a threshold used for preventing an inconvenience caused by high temperature, which will be described later. Hereinafter, the high-temperature protection threshold will be described.

15 **[0086]** The inhaler device 100 includes, as the sensor 112, a first temperature detector that detects a temperature. An example of the first temperature detector is a thermistor. The thermistor is a resistor whose electrical resistance value changes with a change in temperature, and is capable of detecting a temperature based on the electrical resistance value. The first temperature detector detects the temperature of a portion of the inhaler device 100 expected to be in contact with the user at user's inhalation of the aerosol. As an example, the first temperature detector is provided near the outer housing 11 and detects the temperature of the outer housing 11. In this case, it is possible to detect the temperature felt by the user when the user holds the inhaler device 100 with his/her hand and uses the inhaler device 100.

20 **[0087]** Then, the controller 116 controls the operation of the heater 121 in accordance with whether the temperature detected by the first temperature detector exceeds the high-temperature protection threshold. With this configuration, it is possible to implement heating in accordance with the temperature sensed by the hand of the user.

25 **[0088]** Specifically, the controller 116 prohibits supply of electric power to the heater 121 when the temperature detected by the first temperature detector exceeds the high-temperature protection threshold. Thus, when heating by the heater 121 is being executed, heating is interrupted. Before heating by the heater 121 is executed, heating is not started. With this configuration, for example, it is possible to interrupt heating before the temperature of the outer housing 11 becomes excessively high, or not to start heating when it is expected that the temperature of the outer housing 11 becomes excessively high. Thus, it is possible to prevent an inconvenience caused by high temperature such as burn of the user.

30 **[0089]** In contrast, when the temperature detected by the first temperature detector is the high-temperature protection threshold or lower, the controller 116 permits supply of electric power to the heater 121. Thus, when heating by the heater 121 is being executed, heating is continued. Before heating by the heater 121 is executed, heating is started in response to pressing of the switch 13. With this configuration, it is possible to execute heating and deliver the aerosol to the user as long as the inconvenience caused by high temperature can be prevented.

35 **[0090]** The operation setting may include a plurality of high-temperature protection thresholds set for respective elapsed times since the start of heating. In this case, the controller 116 controls the operation of the heater 121 in accordance with whether the temperature detected by the first temperature detector exceeds the high-temperature protection threshold corresponding to the elapsed time since the start of heating among the plurality of high-temperature protection thresholds. As an example, the operation setting includes a high-temperature protection threshold TH_A to be used after T_A seconds have elapsed since the start of heating based on the heating profile, and a high-temperature protection threshold TH_B to be used after T_B seconds have elapsed since the start of heating based on the heating profile. In this case, the controller 116 controls the operation of the heater 121 based on the high-temperature protection threshold TH_A after T_A seconds have elapsed since the start of heating based on the heating profile, and based on the high-temperature protection threshold TH_B after T_B seconds have elapsed since the start of heating based on the heating profile. The temperature of the heater 121 changes with a lapse of time since the start of heating based on the heating profile, and the temperature expected to be detected by the first temperature detector may also change accordingly. In this regard, with this configuration, it is possible to more reliably prevent the inconvenience caused by high temperature.

45 **[0091]** The high-temperature protection threshold may be different on a heating profile basis. That is, the high-temperature protection threshold may be set on a heating profile basis. The temperature expected to be detected by the first temperature detector may be different on a heating profile basis. In this regard, with this configuration, it is possible to more reliably prevent the inconvenience caused by high temperature.

(2.3) Puff detection reference

55 **[0092]** The operation setting may include a puff detection reference. The puff detection reference is a detection reference used for detecting that an aerosol has been inhaled by the user. Hereinafter, the puff detection reference will be described.

[0093] The inhaler device 100 includes, as the sensor 112, a second temperature detector that detects a temperature that changes when the aerosol is inhaled by the user. An example of the second temperature detector is a thermistor.

The second temperature detector is disposed near a flow path of the aerosol, for example, near the holder 140. When the user puffs, in exchange for the fact that the aerosol is inhaled by the user, outside air that is not affected by heating by the heater 121 flows into the flow path of the aerosol, and the temperature detected by the second temperature detector decreases. The puff detection reference is a reference for detecting that the temperature detected by the second temperature detector has decreased with a puff.

[0094] The puff detection reference includes a puff detection threshold. The puff detection threshold is a threshold used for puff detection. The controller 116 detects that the aerosol has been inhaled by the user by comparing a value corresponding to the temperature detected by the second temperature detector, with the puff detection threshold. An example of the value corresponding to the temperature detected by the second temperature detector is an output value obtained by inputting the temperature detected by the second temperature detector to a filter. The output value corresponds to the amount of decrease in the temperature detected by the second temperature detector. An example of the filter is a digital filter, such as a finite impulse response (FIR) filter or an infinite impulse response (IIR) filter. For example, when the output value obtained by inputting the temperature detected by the second temperature detector to the filter exceeds the puff detection threshold, the controller 116 may detect that a puff has been performed. With this configuration, it is possible to detect a puff based on the fact that the temperature detected by the second temperature detector has decreased with the puff.

[0095] The puff detection reference may further include a puff detection filter coefficient in addition to the puff detection threshold. The puff detection filter coefficient is a coefficient of a filter used for puff detection. The controller 116 detects that the aerosol has been inhaled by the user by comparing an output value obtained by inputting the temperature detected by the second temperature detector to the filter having the puff detection filter coefficient applied, with the puff detection threshold. For example, when the output value obtained by inputting the temperature detected by the second temperature detector to the filter having the puff detection filter coefficient applied exceeds the puff detection threshold, the controller 116 detects that a puff has been performed. By using a filter having an appropriate puff detection filter coefficient applied, detection precision of a puff can be improved.

[0096] The puff detection reference may include a plurality of puff detection thresholds set for respective elapsed times since the start of heating. In this case, the controller 116 detects that the aerosol has been inhaled by the user based on the puff detection threshold corresponding to the elapsed time since the start of heating among the plurality of puff detection thresholds. As an example, the puff detection reference includes a puff detection threshold TH_A to be used after T_A seconds have elapsed since the start of heating based on the heating profile, and a puff detection threshold TH_B to be used after T_B seconds have elapsed since the start of heating based on the heating profile. In this case, the inhaler device 100 detects a puff based on the puff detection threshold TH_A after T_A seconds have elapsed since the start of heating based on the heating profile, and detects a puff based on the puff detection threshold TH_B after T_B seconds have elapsed since the start of heating based on the heating profile. The temperature of the heater 121 changes with a lapse of time since the start of heating based on the heating profile, and the temperature detected by the second temperature detector may also change accordingly. In this regard, with this configuration, it is possible to improve the detection precision of the puff.

[0097] The puff detection reference may be different on a heating profile basis. That is, the puff detection reference may be set on a heating profile basis. Considering that the temperature detected by the second temperature detector may be different on a heating profile basis, with this configuration, it is possible to improve the detection precision of the puff.

(2.4) Remaining battery decrease determination threshold

[0098] The operation setting may include a remaining battery decrease determination threshold. The remaining battery decrease determination threshold is a threshold used for detecting a decrease in the remaining electric power stored in the power supply 111. Hereinafter, the remaining battery decrease determination threshold will be described.

[0099] As an example, the remaining battery decrease determination threshold is set as a value more than or equal to the amount of electric power used for the heater 121 to execute the processing of heating the stick substrate 150 to generate an aerosol a prescribed number of times. The processing of heating the stick substrate 150 to generate an aerosol is executed once for one stick substrate 150, and the prescribed number of times corresponds to the number of stick substrates 150 to be consumed. Consumption here means that heating the stick substrate 150 based on the heating profile is executed from the beginning to the end without interruption. That is, the remaining battery decrease determination threshold is a value more than or equal to the amount of electric power used to consume the prescribed number of stick substrates 150. With this configuration, the inhaler device 100 can determine whether the power supply 111 has a sufficient remaining electric power for consuming the prescribed number of stick substrates 150.

[0100] The prescribed number of times may be one. In this case, it is possible to determine whether the inhaler device 100 has the remaining electric power used to consume one stick substrate 150.

[0101] The controller 116 compares the remaining electric power of the power supply 111 with the remaining battery

decrease determination threshold, and controls the operation of the inhaler device 100 based on the comparison result. As an example, the controller 116 may prohibit heating by the heater 121 when the remaining electric power of the power supply 111 falls below the remaining battery decrease determination threshold. With this configuration, it is possible to avoid a situation in which the stick substrate 150 is half-consumed due to an insufficient remaining electric power. As another example, the controller 116 may prohibit execution of a procedure for establishing connection between the inhaler device 100 and another device (for example, the terminal device 200) when the remaining electric power of the power supply 111 falls below the remaining battery decrease determination threshold. With this configuration, it is possible to avoid a situation in which the prescribed number of stick substrates 150 cannot be consumed due to an insufficient remaining electric power although the connection procedure has been executed.

[0102] The remaining electric power of the power supply 111 is measured by any method. As an example, the controller 116 may measure the remaining electric power of the power supply 111 based on the voltage of the power supply 111. As another example, the controller 116 may measure the remaining electric power of the power supply 111 based on a state of charge (SOC) or a residual charge (RC) of a battery gauge.

[0103] The remaining battery decrease determination threshold may be different on a heating profile basis. That is, the remaining battery decrease determination threshold may be set on a heating profile basis. The amount of electric power consumed to consume one stick substrate 150 may be different on a heating profile basis. Thus, with this configuration, it is possible to more precisely determine a decrease in the remaining electric power of the power supply 111.

(3) Switching of operation setting

[0104] The inhaler device 100 can switch the operation setting of the use subject.

[0105] A suitable operation setting may be different on a type of stick substrate 150 basis. For example, the suitable operation setting may be different in accordance with the types and formulations of the aerosol source and the flavor source contained in the stick substrate 150. In this regard, it is possible to improve the quality of a user's experience by switching the operation setting of the use subject in accordance with the type of stick substrate 150.

[0106] An operation setting according to a preference of the user may be used as the operation setting of the use subject. For example, which operation setting is preferred between an operation setting in which the amount of aerosol generated per unit time is large and an operation setting in which the amount of aerosol generated per unit time is small may be different on a user basis. In this regard, it is possible to improve the quality of the user's experience by switching the operation setting of the use subject in accordance with the preference of the user.

[0107] The switching method may be any method. As an example, the inhaler device 100 may switch the operation setting of the use subject based on a user's operation on the inhaler device 100. As another example, the inhaler device 100 may switch the operation setting of the use subject based on a signal received from the terminal device 200. As still another example, the inhaler device 100 may identify the inserted stick substrate 150 and switch the operation setting of the use subject based on the identification result. The stick substrate 150 is identified through, for example, image recognition of a two-dimensional code or the like given to the stick substrate 150.

[0108] Hereinafter, an example in which the inhaler device 100 switches the operation setting of the use subject based on the signal received from the terminal device 200 will be described in detail.

- Transmission of information indicating operation setting stored in inhaler device 100

[0109] The inhaler device 100 transmits information indicating an operation setting stored in the memory 114. The information is received by the terminal device 200. Accordingly, the terminal device 200 can recognize the operation setting stored in the inhaler device 100.

[0110] The terminal device 200 may transmit information for requesting transmission of the information indicating the operation setting. When receiving the information for requesting the transmission of the information indicating the operation setting, the inhaler device 100 transmits the information indicating the operation setting requested to be transmitted in the received information. With this configuration, the terminal device 200 can acquire the information indicating the operation setting from the inhaler device 100 as necessary.

[0111] The inhaler device 100 may transmit identification information corresponding to the operation setting as the information indicating the operation setting. An example of the identification information is a number corresponding to the operation setting. With this configuration, it is possible to reduce the amount of communication compared to a case where the operation setting itself is transmitted.

[0112] When receiving the information indicating the operation setting stored in the inhaler device 100, the terminal device 200 performs processing based on the received information. As an example, the terminal device 200 outputs the received information indicating the operation setting. With this configuration, the user can easily recognize the operation setting stored in the inhaler device 100.

- Display of operation setting that can be used

5 [0113] The terminal device 200 outputs information indicating one or more operation settings that the inhaler device 100 can use as an operation setting of a use subject. An example of the information indicating the one or more operation settings that the inhaler device 100 can use as the operation setting of the use subject is information indicating an operation setting that has already been stored in the inhaler device 100. Another example of the information indicating the one or more operation settings that the inhaler device 100 can use as the operation setting of the use subject is information indicating an operation setting that can be downloaded to the inhaler device 100 (for example, that can be transmitted from the terminal device 200 to the inhaler device 100). An example of a user interface (UI) will be described with reference to Fig. 6.

10 [0114] Fig. 6 is a diagram illustrating an example of a display screen displayed by the terminal device 200 according to the present embodiment. It is assumed that the inhaler device 100 can use an "operation setting 1", an "operation setting 2", and an "operation setting 3" as an operation setting of a use subject. Thus, as illustrated in Fig. 6, icons 31A to 31C indicating three operation settings are displayed on a display screen 30A, as the information indicating the one or more operation settings that the inhaler device 100 can use as the operation setting of the use subject. With this configuration, the user can easily recognize that the inhaler device 100 can use the "operation setting 1", the "operation setting 2", and the "operation setting 3".

15 [0115] The terminal device 200 may store, in the memory 240, the information indicating the one or more operation settings that the inhaler device 100 can use as the operation setting of the use subject. In this case, the terminal device 200 outputs the information indicating the one or more operation settings that are stored in the memory 240 and that the inhaler device 100 can use as the operation setting of the use subject. For example, every time an operation setting is downloaded to the inhaler device 100, the terminal device 200 stores which operation setting has been downloaded to the inhaler device 100 and outputs information indicating the downloaded operation setting. With this configuration, even when the terminal device 200 is not communicating with the inhaler device 100, the terminal device 200 can output the information indicating the one or more operation settings that the inhaler device 100 can use as the operation setting of the use subject.

20 [0116] In addition, the terminal device 200 may acquire information indicating all operation settings stored in the inhaler device 100 from the inhaler device 100 and output the information. In this case, the terminal device 200 transmits information for requesting transmission of the information indicating all the operation settings stored in the inhaler device. When receiving the information, the inhaler device 100 transmits the information indicating all the operation settings stored in the memory 114. Then, the terminal device 200 outputs the received information indicating all the operation settings stored in the inhaler device 100 as the information indicating the one or more operation settings that the inhaler device 100 can use as the operation setting of the use subject. Considering that the inhaler device 100 may download an operation setting from a device other than the terminal device 200, this configuration enables the terminal device 200 to output accurate information.

25 [0117] In addition, the terminal device 200 may acquire information indicating all operation settings stored in the inhaler device 100 from the inhaler device 100 and output the information. In this case, the terminal device 200 transmits information for requesting transmission of the information indicating all the operation settings stored in the inhaler device. When receiving the information, the inhaler device 100 transmits the information indicating all the operation settings stored in the memory 114. Then, the terminal device 200 outputs the received information indicating all the operation settings stored in the inhaler device 100 as the information indicating the one or more operation settings that the inhaler device 100 can use as the operation setting of the use subject. Considering that the inhaler device 100 may download an operation setting from a device other than the terminal device 200, this configuration enables the terminal device 200 to output accurate information.

30 [0117] The terminal device 200 outputs information indicating an operation setting that is being used by the inhaler device 100, that is, an operation setting of a use subject. An example of a UI will be described with reference to Fig. 7.

35 [0118] Fig. 7 is a diagram illustrating an example of a display screen displayed by the terminal device 200 according to the present embodiment. It is assumed that the inhaler device 100 can use an "operation setting 1", an "operation setting 2", or an "operation setting 3" as an operation setting of a use subject. Thus, as illustrated in Fig. 7, icons 31A to 31C indicating three operation settings are displayed on a display screen 30B, as the information indicating the one or more operation settings that the inhaler device 100 can use as the operation setting of the use subject. Further, when the operation setting of the use subject of the inhaler device 100 is the "operation setting 1", the terminal device 200 focuses on the icon 31A corresponding to the "operation setting 1" as illustrated in Fig. 7. With this configuration, the user can easily recognize that the inhaler device 100 operates based on the "operation setting 1".

40 [0119] The terminal device 200 may store information indicating the operation setting of the use subject in the inhaler device 100, in the memory 240. In this case, the terminal device 200 outputs the information indicating the operation setting of the use subject in the inhaler device 100, which is stored in the memory 240. For example, as will be described later, the terminal device 200 may transmit a switching request for the operation setting of the use subject to the inhaler device 100, and may output the information indicating the operation setting of the use subject in the inhaler device 100 based on the transmission history. With this configuration, even when the terminal device 200 is not communicating with the inhaler device 100, the terminal device 200 can output the information indicating the operation setting of the use subject in the inhaler device 100.

45 [0120] In addition, the terminal device 200 may acquire information indicating the operation setting of the use subject in the inhaler device 100 from the inhaler device 100 and output the information. In this case, the terminal device 200

transmits information for requesting transmission of the information indicating the operation setting of the use subject in the inhaler device 100. When receiving the information, the inhaler device 100 transmits the information indicating the operation setting of the use subject. Then, the terminal device 200 outputs the received information indicating the operation setting of the use subject in the inhaler device 100. Considering that the inhaler device 100 may switch the operation setting of the use subject due to a factor other than an instruction from the terminal device 200, this configuration enables the terminal device 200 to output accurate information.

- Switching of operation setting of use subject

[0121] The inhaler device 100 can switch the operation setting of the use subject from among the operation settings stored in the memory 114. For example, based on an instruction from the terminal device 200, the inhaler device 100 can switch the operation setting of the use subject to an operation setting suitable for the type of stick substrate 150, an operation setting according to the preference of the user, or the like. With this configuration, it is possible to improve the quality of the user's experience.

[0122] The terminal device 200 receives a user's operation of selecting an operation setting to be switched to. For example, the terminal device 200 receives a user's operation of selecting an operation setting other than the current operation setting of the use subject as an operation setting to be switched to on a display screen that displays information indicating one or more operation settings that can be used as the operation setting of the use subject. In the display screen 30B illustrated in Fig. 7, the terminal device 200 receives a user's operation of selecting the icon 31B or 31C. The display screen 30B may be displayed on a touch panel serving as both the inputter 210 and the outputter 220. In this case, the user can select the operation setting to be switched to by touching the icon 31B or 31C.

[0123] When receiving the user's operation of selecting the operation setting to be switched to, the terminal device 200 transmits information for instructing switching of the operation setting of the use subject to the selected operation setting to be switched to. For example, identification information indicating the operation setting to be switched to may be transmitted as the information indicating the operation setting to be switched to. When receiving the information, the inhaler device 100 switches the operation setting of the use subject to the operation setting to be switched to instructed in the received information. Thereafter, the inhaler device 100 operates based on the operation setting of the use subject after the switching. With this configuration, the user can switch to a desired operation setting via the terminal device 200.

[0124] When the switching of the operation setting of the use subject has been completed, the inhaler device 100 transmits information indicating that the switching of the operation setting of the use subject has been completed. When receiving the information, the terminal device 200 outputs information indicating the operation setting of the use subject after the switching. For example, the terminal device 200 displays information indicating the operation setting of the use subject after the switching on a display screen that displays information indicating one or more operation settings that can be used as the operation setting of the use subject. For example, an example of a UI when a user's operation of selecting the icon 31B corresponding to the "operation setting 2" has been performed on the display screen 30B illustrated in Fig. 7 will be described with reference to Fig. 8.

[0125] Fig. 8 is a diagram illustrating an example of a display screen displayed by the terminal device 200 according to the present embodiment. It is assumed that the inhaler device 100 can use an "operation setting 1", an "operation setting 2", and an "operation setting 3" as an operation setting of a use subject. Thus, as illustrated in Fig. 8, icons 31A to 31C indicating three operation settings are displayed on a display screen 30C, as the information indicating the one or more operation settings that the inhaler device 100 can use as the operation setting of the use subject. Further, since the operation setting of the use subject after the switching is the "operation setting 2", the terminal device 200 focuses on the icon 31B corresponding to the "operation setting 2" as illustrated in Fig. 8. With this configuration, the user can easily recognize that the operation setting of the use subject has been switched from the "operation setting 1" to the "operation setting 2".

- Flow of processing

[0126] Fig. 9 is a sequence diagram presenting an example of a flow of switching processing for an operation setting of the use subject executed in the system 1 according to the present embodiment. The inhaler device 100 and the terminal device 200 are involved in this sequence.

[0127] As illustrated in Fig. 9, first, the inhaler device 100 and the terminal device 200 establish connection (step S102).

[0128] Then, the terminal device 200 outputs information indicating one or more operation settings that the inhaler device 100 can use as an operation setting of the use subject (step S104). For example, the terminal device 200 outputs the display screen 30A illustrated in Fig. 6.

[0129] Then, the terminal device 200 transmits information for requesting transmission of information indicating an operation setting of the use subject in the inhaler device 100 (step S106). When receiving the information, the inhaler device 100 transmits the information indicating the operation setting of the use subject (S108). Then, when receiving

the information, the terminal device 200 outputs the received information indicating the operation setting of the use subject in the inhaler device 100 (step S110). For example, the terminal device 200 outputs the display screen 30B illustrated in Fig. 7.

5 [0130] Then, the terminal device 200 receives a user's operation of selecting an operation setting to be switched to (step S112). Then, the terminal device 200 transmits information for instructing switching of the operation setting of the use subject to the selected operation setting to be switched to (step S114). When receiving the information, the inhaler device 100 switches the operation setting of the use subject to the operation setting instructed in the received information (step S116).

10 [0131] Thereafter, the inhaler device 100 transmits information indicating that the switching of the operation setting of the use subject has been completed (step S118). When receiving the information, the terminal device 200 outputs information indicating the operation setting of the use subject after the switching (step S120). For example, the terminal device 200 outputs the display screen 30C illustrated in Fig. 8.

(4) Download of operation setting

15 [0132] The terminal device 200 may transmit information indicating an operation setting so that the inhaler device 100 downloads a new operation setting. For example, the terminal device 200 transmits information indicating an operation setting downloaded from a server to the inhaler device 100. Then, the inhaler device 100 stores the operation setting indicated in the received information, in the memory 114. Thereafter, when the newly stored operation setting is selected as the operation setting of the use subject, the inhaler device 100 operates based on the newly stored operation setting. With this configuration, the user can download a desirable operation setting to the inhaler device 100 via the terminal device 200.

(4.1) Content of information indicating operation setting

25 [0133] An example of information indicating an operation setting transmitted and received for download is presented in Table 2 below.

[Table 2]

30 [0134]

Table 2. Example of information indicating operation setting

Section	Content
Step 00	Target resistance value
	Time
	First correction information
	Puff detection threshold
:	:
Step 19	Target resistance value
	Time
	First correction information
	Puff detection threshold
Other	Second correction information
	High-temperature protection threshold
	Puff detection filter coefficient
	Remaining battery decrease determination threshold

55 [0135] As presented in Table 2, the information indicating the operation setting includes a target resistance value, a time, first correction information, and a puff detection threshold as information for each step. The step is a time section obtained by dividing the heating profile in the time direction. The information of a certain step is used when the elapsed

time since the start of heating based on the heating profile is included in the step. For example, a step is a time section having a predetermined time length such as 10 seconds. In this case, step 00 is a time section until a lapse of 10 seconds since the start of heating based on the heating profile. Thus, the information of step 00 is used until a lapse of 10 seconds since the start of heating based on the heating profile. Step 19 is a time section of 10 seconds immediately before the end of heating based on the heating profile. Thus, the information of step 19 is used for 10 seconds immediately before the end of heating based on the heating profile. Note that the time length of the step may be different on a step basis. Also, the number of steps is not limited to 20 from 00 to 19 presented in Table 2.

[0136] Also, as presented in Table 2, the information indicating the operation setting includes second correction information, a high-temperature protection threshold, a puff detection filter coefficient, and a remaining battery decrease determination threshold as other information. These items of information are used throughout the time sections during which the heating based on the heating profile is performed.

[0137] The information indicating the operation setting may be divided into a plurality of items of information and transmitted and received at respective different timings. As an example, information for each step consisting of a combination of the target resistance value, the time, the first correction information, and the puff detection threshold may be transmitted and received at respective different timings. As another example, the information for each step and the other information may be transmitted and received at respective different timings. With this configuration, it is possible to improve communication efficiency, for example, by facilitating retry when a transmission/reception error occurs.

- Default heating profile

[0138] As presented in Table 2, the information indicating the operation setting includes a target resistance value and a time for each step. Here, the time is an elapsed time since the start of heating, within which the target resistance value is to be reached. A combination of an elapsed time since the start of heating and a target resistance value set for the elapsed time in each of all the steps corresponds to the heating profile.

[0139] As described above, the information indicating the operation setting may be divided, and transmitted and received. In particular, the information indicating the heating profile may be divided in the time direction, for example, on a step basis, and transmitted and received. In this case, the information indicating the heating profile divided in the time direction includes at least one combination of an elapsed time since the start of heating and a target resistance value set for the elapsed time. With this configuration, it is possible to improve communication efficiency related to transmission and reception of the heating profile.

[0140] However, the heating profile consisting of the combination of the target resistance value and the time for each step presented in Table 2 is a heating profile before correction (hereinafter also referred to as a default heating profile). The default heating profile is corrected based on first correction information as will be described later. The default heating profile may be corrected based on second correction information as will be described later.

- First correction information

[0141] As presented in Table 2, the information indicating the operation setting includes first correction information. The first correction information is an example of correction information for correcting the operation setting in accordance with an individual difference of the heater 121. An example of the individual difference of the heater 121 is a correspondence relationship between the temperature and the resistance value. When receiving the first correction information, the controller 116 may correct the operation setting based on the received first correction information. In this case, the controller 116 controls the operation of the inhaler device 100 based on the corrected operation setting. With this configuration, the inhaler device 100 can perform the operation in accordance with the individual difference of the heater 121. Thus, the quality of the user's puff experience can be improved.

[0142] Specifically, the controller 116 corrects the heating profile based on the first correction information. More specifically, the controller 116 corrects the default heating profile based on the first correction information. Then, the controller 116 controls the operation of the heater 121 based on the corrected heating profile. With this configuration, it is possible to perform heating based on the heating profile corrected so as to match the individual difference of the heater 121, and thus it is possible to prevent an inconvenience caused by the individual difference of the heater 121. An example of the inconvenience caused by the individual difference of the heater 121 is that the actual temperature of the heater 121 deviates from the target temperature.

[0143] As presented in Table 2, the information indicating the operation setting includes a plurality of items of first correction information associated with a plurality of respective target resistance values included in the heating profile. Then, the controller 116 corrects each of the plurality of target value resistance values defined in the heating profile based on the associated first correction information. For example, the controller 116 corrects the target resistance value included in the information of step 00 based on the first correction information included in the information of step 00. As an example, the first correction information may include an offset correction value that is a value used for offset correction.

In this case, the controller 116 adds the offset correction value to the target resistance value. As another example, the first correction information may include a gain correction value that is a value used for gain correction. In this case, the controller 116 multiplies the target resistance value by the gain correction value. The first correction information may include both the offset correction value and the gain correction value. With this configuration, it is possible to appropriately correct the target resistance value on a step basis.

[0144] The first correction information may be different on a heating profile basis. The degree of occurrence of the inconvenience caused by the individual difference of the heater 121 may be different on a heating profile basis. In this regard, with this configuration, it is possible to more reliably prevent the inconvenience caused by the individual difference of the heater 121.

[0145] In order to enable the terminal device 200 to generate the first correction information, the inhaler device 100 transmits information indicating the individual difference of the heater 121 to the terminal device 200. For example, the inhaler device 100 stores information indicating the individual difference of the heater 121 at the time of manufacturing in a factory, and transmits the stored information to the terminal device 200. With this configuration, the terminal device 200 can recognize the individual difference of the heater 121.

[0146] The terminal device 200 may transmit information for requesting transmission of the information indicating the individual difference of the heater 121. When receiving the information for requesting the transmission of the information indicating the individual difference of the heater 121, the inhaler device 100 transmits the information indicating the individual difference of the heater 121. With this configuration, the terminal device 200 can inquire of the inhaler device 100 about the individual difference of the heater 121 as a preliminary stage of generating the first correction information. The terminal device 200 may store the information indicating the individual difference of the heater 121 received from the inhaler device 100, and thereafter use the stored information.

[0147] When receiving the information indicating the individual difference of the heater 121, the terminal device 200 generates the first correction information based on the received information indicating the individual difference of the heater 121. Then, the terminal device 200 transmits the generated first correction information. The inhaler device 100 receives the first correction information transmitted from the terminal device 200 in this way, and corrects the heating profile based on the received first correction information. With this configuration, it is possible to correct the heating profile based on the first correction information matching the individual difference of the heater 121.

- Second correction information

[0148] As presented in Table 2, the information indicating the operation setting includes second correction information. The second correction information is an example of correction information for correcting the operation setting in accordance with a deterioration of the heater 121. The deterioration of the heater 121 is oxidation of the heater 121 that progresses every time heating by the heater 121 is repeated. When receiving the second correction information, the controller 116 may correct the operation setting based on the received second correction information. In this case, the controller 116 controls the operation of the inhaler device 100 based on the corrected operation setting. With this configuration, the inhaler device 100 can perform an operation in accordance with the deterioration of the heater 121. Thus, the quality of the user's puff experience can be improved.

[0149] Specifically, the controller 116 may correct the heating profile based on the second correction information. More specifically, the controller 116 may further correct the heating profile, which has been corrected based on the first correction information, based on the second correction information. In this case, the controller 116 controls the operation of the heater 121 based on the corrected heating profile. With this configuration, it is possible to perform heating based on the heating profile matching the degree of deterioration of the heater 121. Accordingly, it is possible to prevent an inconvenience caused by the deterioration of the heater 121.

[0150] Hereinafter, correction of the heating profile based on the second correction information will be described in detail.

[0151] The controller 116 integrates a history value indicating a history of heating executed by the heater 121 based on execution of heating by the heater 121. As an example, the controller 116 integrates a history value indicating a history of heating executed by the heater 121 every time heating is performed by the heater 121. As another example, the controller 116 integrates a history value indicating a history of heating executed by the heater 121 every time heating by the heater 121 is performed a plurality of times (for example, twice). As the number of times of heating increases, the heater 121 is oxidized and the resistance value of the heater 121 increases. Then, even though the resistance value of the heater 121 reaches the target resistance value, the actual temperature of the heater 121 does not reach the target temperature by an amount corresponding to the increase in the resistance value of the heater 121 due to oxidation. Thus, even though the operation of the heater 121 is controlled in accordance with the heating profile, it may be difficult to deliver an appropriate flavor to the user. In this regard, with this configuration, it is possible to recognize the degree of oxidation of the heater 121 using the history value.

[0152] As an example, the history value may be an integrated value of the number of times of heating by the heater

121 (hereinafter also referred to as the number of times of heating). Every time heating based on the heating profile is performed once, 1 may be integrated into the history value. That is, the history value may be an integrated value of the number of times of heating by the heater 121 based on the heating profile. While heating based on the heating profile is performed once, execution and stop of short-time heating may be performed a plurality of times, and 1 may be integrated into the history value every time the short-time heating is performed once. In any case, the degree of oxidation of the heater 121 can be recognized using the number of times of heating.

[0153] As another example, the history value may be an integrated value of the time of heating by the heater 121 (hereinafter also referred to as a heating time). Every time heating based on the heating profile is performed once, the time for one heating based on the heating profile may be integrated into the history value. While heating based on the heating profile is performed once, execution and stop of short-time heating may be performed a plurality of times, and a value corresponding to an amount of time taken for the short-time heating may be integrated into the history value. In any case, the degree of oxidation of the heater 121 can be recognized using the heating time.

[0154] The controller 116 corrects the heating profile based on the integrated history value and the second correction information. With this configuration, the heating profile is corrected in accordance with the degree of oxidation of the heater 121 indicated by the history value. Thus, it is possible to prevent the occurrence of an inconvenience caused by the oxidation of the heater 121.

[0155] Specifically, the controller 116 corrects a target resistance value of a correction subject, which is at least a part of the plurality of target resistance values defined in the heating profile, to a value corresponding to a higher temperature. When the resistance value of the heater 121 increases as the temperature of the heater 121 increases, the controller 116 corrects the target resistance value of the correction subject to a higher value. As described above, when the heater 121 is oxidized and the resistance of the heater 121 increases, even though the resistance value of the heater 121 reaches the target resistance value, the actual temperature of the heater 121 becomes lower than the target temperature. In this regard, by correcting the target resistance value to a value corresponding to a higher temperature, it is possible to cancel a decrease in temperature caused by the oxidation of the heater 121 and to implement temperature control that does not change before and after the oxidation. Thus, it is possible to prevent the occurrence of the inconvenience caused by the oxidation of the heater 121.

[0156] The second correction information may include information indicating the target resistance value of the correction subject. In this case, the controller 116 corrects the target resistance value of the correction subject indicated in the second correction information. With this configuration, it is possible to prevent an inconvenience described below for the target resistance value of the correction subject.

[0157] The target resistance value of the correction subject preferably includes a target resistance value corresponding to the lowest target temperature among the plurality of target resistance values defined in the heating profile. One of inconveniences caused by the oxidation of the heater 121 is that the temperature of the stick substrate 150 drops too much even during heating, and the aerosol is no longer generated. The stage at which such an inconvenience is most likely to occur is a stage at which the target temperature corresponding to the target resistance value in the heating profile is the lowest. In this regard, with this configuration, it is possible to prevent the occurrence of such an inconvenience.

[0158] The target resistance value of the correction subject preferably does not include a target resistance value corresponding to the highest target temperature among the plurality of target resistance values defined in the heating profile. When the heating profile is corrected in a state in which the oxidation of the heater 121 has not progressed more than expected, the actual temperature may become excessively higher than the target temperature before correction, and the function of the inhaler device 100 may be damaged. The stage at which such an inconvenience is most likely to occur is a stage at which the target temperature corresponding to the target resistance value in the heating profile is the highest. In this regard, with this configuration, it is possible to prevent such an inconvenience.

[0159] The second correction information may include information indicating a threshold. In this case, the controller 116 corrects the heating profile when the history value exceeds the threshold indicated in the second correction information. As an example, the controller 116 may correct the heating profile when the number of times of heating exceeds 1000 times. As another example, the controller 116 may correct the heating profile every time the heating time exceeds 100,000 seconds. With this configuration, since the correction frequency of the heating profile is suppressed, it is possible to reduce the processing load of the controller 116.

[0160] The second correction information may include information indicating a correction method of the heating profile. In this case, the controller 116 corrects the heating profile based on the correction method indicated in the second correction information. As an example, the second correction information may include a value to be added to the target resistance value. In this case, the controller 116 adds the value to be added to the target resistance value included in the second correction information to the target resistance value before correction. With this configuration, it is possible to appropriately correct the target resistance value.

[0161] The second correction information may be different on a heating profile basis. The change in temperature of the heater 121 may be different on a heating profile basis, and the progress degree of the oxidation of the heater 121 may be different. In this regard, with this configuration, it is possible to more reliably prevent the inconvenience caused

by the oxidation of the heater 121.

[0162] Here, the history value may be integrated on a heating profile basis. Then, the inhaler device 100 may store the history value and the second correction information for each heating profile and use the history value and the second correction information for correction of the heating profile. Specifically, the inhaler device 100 may integrate the correction based on the history value and the second correction information for all the heating profiles used so far, and apply the integrated correction to the heating profile. It is considered that the oxidation of the heater 121 begins at the time of manufacture and proceeds in accordance with the heating profile used. In this regard, with this configuration, it is possible to perform correction in accordance with the past use history of the inhaler device 100.

- High-temperature protection threshold

[0163] As presented in Table 2, the information indicating the operation setting includes information indicating a high-temperature protection threshold. When receiving the information indicating the operation setting including the high-temperature protection threshold, the controller 116 may control the operation of the heater 121 in accordance with whether the temperature detected by the first temperature detector exceeds the received high-temperature protection threshold. With this configuration, it is possible to prevent the inconvenience caused by high temperature in accordance with the newly downloaded operation setting.

[0164] In Table 2, the information indicating the operation setting includes one high-temperature protection threshold; however, the present invention is not limited to this example. The information indicating the operation setting may include information indicating a plurality of high-temperature protection thresholds set for respective elapsed times since the start of heating. Referring to Table 2, the information indicating the operation setting may include a high-temperature protection threshold on a step basis. In this case, the inhaler device 100 controls the operation of the heater 121 in accordance with whether the temperature detected by the first temperature detector exceeds the high-temperature protection threshold of the step corresponding to the elapsed time since the start of heating based on the heating profile. With this configuration, it is possible to more reliably prevent the inconvenience caused by high temperature.

- Puff detection reference

[0165] As presented in Table 2, the information indicating the operation setting includes information indicating a puff detection reference. That is, the information indicating the operation setting includes a puff detection threshold. In particular, the information indicating the operation setting includes the puff detection threshold for each step as information indicating a plurality of puff detection thresholds set for respective elapsed times since the start of heating. Further, the information indicating the operation setting includes a puff detection filter coefficient. When receiving the information indicating the operation setting including the information indicating the puff detection reference, the controller 116 may detect that the aerosol has been inhaled by the user based on the received detection reference. With this configuration, it is possible to detect a puff in accordance with the newly downloaded operation setting.

- Remaining battery decrease determination threshold

[0166] As presented in Table 2, the information indicating the operation setting includes information indicating a remaining battery decrease determination threshold. When receiving the information indicating the operation setting including the remaining battery decrease determination threshold, the controller 116 may control the operation of the inhaler device 100 based on the received remaining battery decrease determination threshold. With this configuration, it is possible to perform control when the remaining electric power of the power supply 111 decreases in accordance with the newly downloaded operation setting.

(4.2) UI related to download of operation setting

[0167] The terminal device 200 may output a UI related to download of the operation setting. Then, the terminal device 200 may download the operation setting to the inhaler device 100 in response to a user's operation on the UI. An example of the UI will be described with reference to Fig. 10.

[0168] Fig. 10 is a diagram illustrating an example of a display screen displayed by the terminal device 200 according to the present embodiment. It is assumed that the inhaler device 100 can use an "operation setting 1", an "operation setting 2", and an "operation setting 3" as an operation setting of a use subject. Thus, as illustrated in Fig. 10, icons 31A to 31C indicating three operation settings are displayed on a display screen 30D, as the information indicating the one or more operation settings that the inhaler device 100 can use as the operation setting of the use subject.

[0169] However, it is assumed that the "operation setting 1" and the "operation setting 2" have already been downloaded to the inhaler device 100, whereas the "operation setting 3" has not yet been downloaded to the inhaler device 100.

Thus, as illustrated in Fig. 10, the icons 31A and 31B are framed with solid lines to indicate that the icons 31A and 31B have been downloaded. In contrast, the icon 31C is framed with a broken line indicating that the icon 31C has not been downloaded. As in this example, it is desirable that information indicating the operation setting that has been downloaded and information indicating the operation setting that has not been downloaded be displayed in different modes.

5 **[0170]** Also, it is assumed that the operation setting of the use subject of the inhaler device 100 is the "operation setting 1". Thus, as illustrated in Fig. 10, the icon 31A corresponding to the "operation setting 1" is in focus.

[0171] The terminal device 200 receives an operation of selecting an operation setting to be transmitted to the inhaler device 100. Then, the terminal device 200 transmits information indicating the selected operation setting. For example, when the icon 31C is touched by the user, the terminal device 200 transmits the information presented in Table 2 and related to the "operation setting 3". With this configuration, the user can download a desirable operation setting to the inhaler device 100 via the terminal device 200.

10 **[0172]** When the download of the operation setting has been completed, the inhaler device 100 transmits information indicating that the download of the operation setting has been completed. As an example, when the inhaler device 100 has successfully received the information presented in Table 2 and related to the "operation setting 3", the inhaler device 100 transmits the information indicating that the download of the operation setting has been completed. The terminal device 200 may control retransmission of the information indicating the operation setting in accordance with whether the information has been received. With this configuration, it is possible to reliably succeed in downloading the operation setting.

15 **[0173]** In particular, when the correction of the heating profile based on the first correction information has been completed, the inhaler device 100 transmits the information indicating that the download of the operation setting has been completed. That is, the information indicating that the download of the operation setting has been completed may also serve as information indicating that the correction of the heating profile based on the first correction information has been completed. With this configuration, it is possible to notify the user via the terminal device 200 of that the inhaler device 100 can use the corrected heating profile.

20 **[0174]** The terminal device 200 receives the information indicating that the download of the operation setting to the inhaler device 100 has been completed. Accordingly, the terminal device 200 can recognize that the newly downloaded operation setting can be used as the operation setting of the use subject.

25 **[0175]** When receiving the information indicating that the download of the operation setting to the inhaler device 100 has been completed, the terminal device 200 outputs information indicating the information indicating that the download of the operation setting to the inhaler device 100 has been completed. Accordingly, the user can recognize that the newly downloaded operation setting can be used as the operation setting of the use subject. For example, an example of a UI displayed when a user's operation of selecting the icon 31C corresponding to the "operation setting 3" has been performed on the display screen 30D illustrated in Fig. 10 and the download of the "operation setting 3" has been completed will be described with reference to Fig. 11.

30 **[0176]** Fig. 11 is a diagram illustrating an example of a display screen displayed by the terminal device 200 according to the present embodiment. As illustrated in Fig. 11, icons 31A to 31C indicating three operation settings are displayed on a display screen 30E, as the information indicating the one or more operation settings that the inhaler device 100 can use as the operation setting of the use subject. In particular, since the download of the "operation setting 3" has been completed, the icon 31C indicating the "operation setting 3" is framed with a solid line indicating that the download has been completed. In the display screen 30D illustrated in Fig. 10, the user's operation of selecting the icon 31C corresponding to the "operation setting 3" may also serve as an operation of instructing switching of the "operation setting 3" to the operation setting of the use subject. In this case, the inhaler device 100 switches the operation setting of the use subject to the "operation setting 3" after the download has been completed. Then, as illustrated in Fig. 11, the terminal device 200 focuses on the icon 31C corresponding to the "operation setting 3". With this configuration, the user can easily recognize that the download of the "operation setting 3" has been completed and that the operation setting of the use subject has been switched from the "operation setting 1" to the "operation setting 3".

(4.3) Flow of processing

50 **[0177]** Fig. 12 is a sequence diagram presenting an example of a flow of download processing for an operation setting executed in the system 1 according to the present embodiment. The inhaler device 100 and the terminal device 200 are involved in this sequence.

[0178] As illustrated in Fig. 12, first, the inhaler device 100 and the terminal device 200 establish connection (step S202).

55 **[0179]** Then, the terminal device 200 outputs information indicating an operation setting that can be downloaded to the inhaler device 100 (step S204). For example, the terminal device 200 outputs the display screen 30D illustrated in Fig. 10.

[0180] Then, the terminal device 200 receives a user's operation of selecting an operation setting to be downloaded (step S206). For example, the terminal device 200 receives a user's operation of touching the icon 31C corresponding

to the "operation setting 3" on the display screen 30D illustrated in Fig. 10.

[0181] Then, the terminal device 200 transmits information for requesting transmission of information indicating the individual difference of the heater 121 (step S208). When receiving the information, the inhaler device 100 transmits the information indicating the individual difference of the heater 121 (step S210). When the information indicating the individual difference of the heater 121 has already been stored in the terminal device 200, the processing related to step S208 and step S210 may be omitted.

[0182] Then, the terminal device 200 generates information indicating the operation setting (step S212). For example, the terminal device 200 generates the information presented in Table 2. Specifically, the terminal device 200 generates first correction information based on a default heating profile in the selected "operation setting 3" and the information indicating the individual difference of the heater 121. Also, the terminal device 200 generates second correction information, a high-temperature protection threshold, a puff detection threshold, a puff detection filter coefficient, and a remaining battery decrease determination threshold based on the default heating profile in the selected "operation setting 3".

[0183] Then, the terminal device 200 transmits items of information indicating divided operation settings at respective different timings (step S214). For example, the terminal device 200 transmits items of information for respective steps presented in Table 2 at respective different timings, and then transmits the other information.

[0184] Then, the inhaler device 100 transmits information indicating that the download of the operation setting has been completed (step S216). For example, when the inhaler device 100 has successfully received all the items of information indicating the divided operation settings and completed the correction of the default heating profile based on the first correction information, the inhaler device 100 transmits the information indicating that the download of the operation setting has been completed.

[0185] When receiving the information indicating that the download of the operation setting has been completed, the terminal device 200 outputs the information indicating that the download of the operation setting has been completed (step S218). For example, the terminal device 200 outputs the display screen 30E illustrated in Fig. 11.

3. Supplement

[0186] Although the preferred embodiments of the present invention have been described in detail with reference to the accompanying drawings, the present invention is not limited to these examples. It will be apparent to those who have ordinary knowledge in the technical field to which the present invention pertains that various changes and modifications can be made within the scope of the technical idea as defined in the appended claims. It is to be understood that the changes and modifications also obviously pertain to the technical scope of the present invention.

[0187] Although the example in which the information presented in Table 2 is transmitted and received in order to download the operation setting to the inhaler device 100 has been described in the above embodiment, the present invention is not limited to this example. The terminal device 200 may transmit information including at least one of the target resistance value, the time, the first correction information, the second correction information, the puff detection threshold, the puff detection filter coefficient, the high-temperature protection threshold, and the remaining battery decrease determination threshold as the information indicating the operation setting. That is, the information presented in Table 2 may be partially omitted. The inhaler device 100 uses a default setting for the omitted information. For example, when the puff detection filter coefficient is not included in the received information, the inhaler device 100 detects a puff using a default puff detection filter coefficient.

[0188] Although the example in which the first temperature detector detects the temperature of the outer housing 11 has been described in the above embodiment, the present invention is not limited to this example. As an example, the first temperature detector may be provided near a processor such as the controller 116 to detect the temperature of the processor. In this case, the inhaler device 100 prohibits supply of electric power to the heater 121 when the temperature of the processor exceeds a high-temperature protection threshold. With this configuration, it is possible to prevent an inconvenience caused by high temperature such as thermal runaway of the processor. As another example, the first temperature detector may be provided near the power supply 111 to detect the temperature of the power supply 111. In this case, the inhaler device 100 prohibits supply of electric power to the heater 121 when the temperature of the power supply 111 exceeds a high-temperature protection threshold. With this configuration, it is possible to prevent an inconvenience caused by high temperature such as a deterioration of the battery.

[0189] Although the example in which the output value obtained by inputting the temperature detected by the second temperature detector to the filter is compared with the puff detection threshold to detect that a puff has been performed has been described in the above embodiment, the present invention is not limited to this example. As an example, the inhaler device 100 may detect that a puff has been performed when the temperature detected by the second temperature detector falls below a puff detection threshold. As another example, the inhaler device 100 may detect that a puff has been performed when the difference between a reference temperature and the temperature detected by the second temperature detector exceeds a puff detection threshold. An example of the reference temperature is a temperature of

the second temperature detector a predetermined time before (for example, immediately before). In this case, the difference corresponds to a decrease in the temperature detected by the second temperature detector.

[0190] Although the example in which the second temperature detector is a thermistor has been described in the above embodiment, the present invention is not limited to this example. The second temperature detector may be the heater 121. In this case, the inhaler device 100 detects a puff based on a change in the temperature indicated by the resistance value of the heater 121 or a change in the resistance value of the heater 121.

[0191] Although the example in which the information indicating the heating profile is divided in the time direction, and transmitted and received has been described in the above embodiment, the present invention is not limited to this example. For example, the information indicating the heating profile may be divided in a direction of the target resistance value, and transmitted and received. Specifically, information related to a relatively high target resistance value and information related to a relatively low target resistance value may be transmitted and received in a divided manner. Even in this case, the information indicating the divided heating profile includes at least one combination of an elapsed time since the start of heating and a target resistance value set for the elapsed time. With this configuration, it is possible to restore the heating profile on the reception side no matter how it is divided.

[0192] The timing of correcting the heating profile described in the above embodiment is merely an example, and the heating profile may be corrected at any other timing. As an example, the inhaler device 100 may execute the correction of the heating profile based on the first correction information when the controller 116 is activated. As another example, the inhaler device 100 may execute the correction of the heating profile based on the second correction information when the controller 116 is activated.

[0193] Although the example in which the inhaler device 100 heats the stick substrate 150 as the substrate containing the aerosol source to generate the aerosol has been described in the above embodiment, the shape of the substrate is not limited to a stick shape. Another example of the shape of the substrate is a card shape. Still another example of the shape of the substrate is a cube shape. Also, the inhaler device 100 may use a capsule-shaped substrate which does not contain an aerosol source and contains, for example, only a flavor source to generate an aerosol to be inhaled by the user. As an example, a capsule-shaped second substrate containing a flavor source is disposed on the downstream side of a first substrate containing an aerosol source. When an aerosol generated by heating the first substrate passes through the second substrate, a flavor is imparted to the aerosol from the flavor source contained in the second substrate, and the aerosol is delivered to the user.

[0194] Note that the series of processing performed by each device described in the present description may be implemented using any of software, hardware, and a combination of software and hardware. A program constituting the software is stored in advance in, for example, a recording medium (non-transitory media) provided inside or outside each device. For example, each program is read into a RAM and executed by a processor such as a CPU at the time of execution by a computer that controls each device described in the present description. The recording medium is, for example, a magnetic disk, an optical disk, a magneto-optical disk, a flash memory, or the like. The computer program may be distributed via a network, for example, without using a recording medium.

[0195] Also, the processing described using the flowcharts and the sequence diagrams in the present description do not have to be executed in the illustrated order. Some of the processing steps may be performed in parallel. Also, an additional processing step may be employed, or the processing steps may be partially omitted.

[0196] The following configurations also pertain to the technical scope of the present invention.

(1) An inhaler device comprising:

a communicator that communicates with another device;
a heater that heats a substrate containing an aerosol source to generate an aerosol; and
a controller that controls an operation of the inhaler device based on an operation setting that is information for setting the operation of the inhaler device,
wherein the communicator receives correction information for correcting the operation setting in accordance with an individual difference of the heater.

(2) The inhaler device according to said (1),

wherein the controller corrects the operation setting based on the correction information and controls an operation of the heater based on the corrected operation setting.

(3) The inhaler device according to said (2),

wherein the operation setting includes a heating profile that defines a time-series transition of a target value for an actual measurement value measured for the heater, and
wherein the controller corrects the heating profile based on the correction information and controls the operation of the heater based on the corrected heating profile.

(4) The inhaler device according to said (3),
wherein the heating profile is divided into a plurality of heating profiles, and the communicator receives items of information indicating the divided heating profiles at different timings.

(5) The inhaler device according to said (4),
wherein the heating profile is divided into the plurality of heating profiles in a time direction, and the communicator receives the items of information indicating the divided heating profiles at the different timings.

(6) The inhaler device according to said (5),

wherein the target value includes a plurality of target values included in the heating profiles, the correction information includes a plurality of items of correction information, and the communicator receives the plurality of items of correction information associated with the plurality of respective target values, and
wherein the controller corrects each of the plurality of target values defined in the heating profiles based on the associated correction information.

(7) The inhaler device according to any one of said (3) to (6),
wherein the communicator transmits information indicating that the correction of the heating profile based on the correction information has been completed.

(8) The inhaler device according to any one of said (1) to (7),
wherein the communicator transmits information indicating the individual difference of the heater.

(9) The inhaler device according to said (8),
wherein, when receiving information for requesting transmission of the information indicating the individual difference of the heater, the communicator transmits the information indicating the individual difference of the heater.

(10) A terminal device comprising:

a communicator that transmits correction information for correcting an operation setting in accordance with an individual difference of a heater, the operation setting being information for setting an operation of an inhaler device, the inhaler device including the heater that heats a substrate containing an aerosol source to generate an aerosol.

(11) The terminal device according to said (10),
wherein the communicator receives information indicating the individual difference of the heater and transmits the correction information generated based on the received information indicating the individual difference of the heater.

(12) The terminal device according to said (11),
wherein the communicator transmits information for requesting transmission of the information indicating the individual difference of the heater.

(13) The terminal device according to any one of said (10) to (12),

wherein the operation setting includes a heating profile that defines a time-series transition of a target value for an actual measurement value measured for the heater, and
wherein the correction information is used for correcting the heating profile.

(14) The terminal device according to said (13), further comprising:

an inputter that receives an operation of selecting the operation setting to be transmitted to the inhaler device, wherein the communicator transmits information indicating the heating profile and the correction information, as information indicating the selected operation setting.

(15) The terminal device according to said (14),
wherein the heating profile is divided into a plurality of heating profiles, and the communicator transmits items of information indicating the divided heating profiles at different timings.

(16) The terminal device according to said (15),
wherein the heating profile is divided into the plurality of heating profiles in a time direction, and the communicator transmits the items of information indicating the divided heating profiles at the different timings.

(17) The terminal device according to said (16),
wherein the target value includes a plurality of target values included in the heating profiles, the correction information includes a plurality of items of correction information, and the communicator transmits the plurality of items of correction information associated with the plurality of respective target values.

(18) The terminal device according to any one of said (14) to (17),
wherein the communicator receives information indicating that the correction of the heating profile based on the correction information in the inhaler device has been completed.

(19) The terminal device according to said (18), further comprising:

an outputter that outputs information,
 wherein the outputter outputs, when the communicator has received the information indicating that the correction
 of the heating profile based on the correction information in the inhaler device has been completed, the infor-
 mation indicating that the correction of the heating profile based on the correction information in the inhaler
 device has been completed.

(20) A program that causes a computer to execute:
 controlling a terminal device to transmit correction information for correcting an operation setting in accordance with
 an individual difference of a heater, the operation setting being information for setting an operation of an inhaler
 device, the inhaler device including the heater that heats a substrate containing an aerosol source to generate an
 aerosol.

Reference Signs List

[0197]

- 1 system
- 100 inhaler device
- 111 power supply
- 112 sensor
- 113 notifier
- 114 memory
- 115 communicator
- 116 controller
- 140 holder
- 141 internal space
- 142 opening
- 143 bottom
- 144 heat insulator
- 150 stick substrate
- 151 substrate
- 152 inhalation port
- 11 outer housing
- 11A top housing
- 11B bottom housing
- 12 cover
- 13 switch
- 14 lid
- 15 vent
- 16 cap
- 200 terminal device
- 210 inputter
- 220 outputter
- 230 communicator
- 240 memory
- 250 controller

Claims

1. An inhaler device comprising:

a communicator that communicates with another device;
 a heater that heats a substrate containing an aerosol source to generate an aerosol; and
 a controller that controls an operation of the inhaler device based on an operation setting that is information for
 setting the operation of the inhaler device,
 wherein the communicator receives correction information for correcting the operation setting in accordance
 with an individual difference of the heater.

2. The inhaler device according to claim 1,
wherein the controller corrects the operation setting based on the correction information and controls an operation of the heater based on the corrected operation setting.
- 5 3. The inhaler device according to claim 2,

wherein the operation setting includes a heating profile that defines a time-series transition of a target value for an actual measurement value measured for the heater, and
10 wherein the controller corrects the heating profile based on the correction information and controls the operation of the heater based on the corrected heating profile.
4. The inhaler device according to claim 3,
wherein the heating profile is divided into a plurality of heating profiles, and the communicator receives items of information indicating the divided heating profiles at different timings.
- 15 5. The inhaler device according to claim 4,
wherein the heating profile is divided into the plurality of heating profiles in a time direction, and the communicator receives the items of information indicating the divided heating profiles at the different timings.
- 20 6. The inhaler device according to claim 5,

wherein the target value includes a plurality of target values included in the heating profiles, the correction information includes a plurality of items of correction information, and the communicator receives the plurality of items of correction information associated with the plurality of respective target values, and
25 wherein the controller corrects each of the plurality of target values defined in the heating profiles based on the associated correction information.
7. The inhaler device according to any one of claims 3 to 6,
wherein the communicator transmits information indicating that the correction of the heating profile based on the correction information has been completed.
- 30 8. The inhaler device according to any one of claims 1 to 7,
wherein the communicator transmits information indicating the individual difference of the heater.
- 35 9. The inhaler device according to claim 8,
wherein, when receiving information for requesting transmission of the information indicating the individual difference of the heater, the communicator transmits the information indicating the individual difference of the heater.
- 40 10. A terminal device comprising:
a communicator that transmits correction information for correcting an operation setting in accordance with an individual difference of a heater, the operation setting being information for setting an operation of an inhaler device, the inhaler device including the heater that heats a substrate containing an aerosol source to generate an aerosol.
- 45 11. The terminal device according to claim 10,
wherein the communicator receives information indicating the individual difference of the heater and transmits the correction information generated based on the received information indicating the individual difference of the heater.
12. The terminal device according to claim 11,
wherein the communicator transmits information for requesting transmission of the information indicating the individual difference of the heater.
- 50 13. The terminal device according to any one of claims 10 to 12,

wherein the operation setting includes a heating profile that defines a time-series transition of a target value for an actual measurement value measured for the heater, and
55 wherein the correction information is used for correcting the heating profile.
14. The terminal device according to claim 13, further comprising:

an inputter that receives an operation of selecting the operation setting to be transmitted to the inhaler device, wherein the communicator transmits information indicating the heating profile and the correction information, as information indicating the selected operation setting.

5 **15.** The terminal device according to claim 14,
 wherein the heating profile is divided into a plurality of heating profiles, and the communicator transmits items of
 information indicating the divided heating profiles at different timings.

10 **16.** The terminal device according to claim 15,
 wherein the heating profile is divided into the plurality of heating profiles in a time direction, and the communicator
 transmits the items of information indicating the divided heating profiles at the different timings.

15 **17.** The terminal device according to claim 16,
 wherein the target value includes a plurality of target values included in the heating profiles, the correction information
 includes a plurality of items of correction information, and the communicator transmits the plurality of items of
 correction information associated with the plurality of respective target values.

20 **18.** The terminal device according to any one of claims 14 to 17,
 wherein the communicator receives information indicating that the correction of the heating profile based on the
 correction information in the inhaler device has been completed.

19. The terminal device according to claim 18, further comprising:

25 an outputter that outputs information,
 wherein the outputter outputs, when the communicator has received the information indicating that the correction
 of the heating profile based on the correction information in the inhaler device has been completed, the infor-
 mation indicating that the correction of the heating profile based on the correction information in the inhaler
 device has been completed.

30 **20.** A program that causes a computer to execute:
 controlling a terminal device to transmit correction information for correcting an operation setting in accordance with
 an individual difference of a heater, the operation setting being information for setting an operation of an inhaler
 device, the inhaler device including the heater that heats a substrate containing an aerosol source to generate an
 aerosol.
35

40

45

50

55

FIG. 1

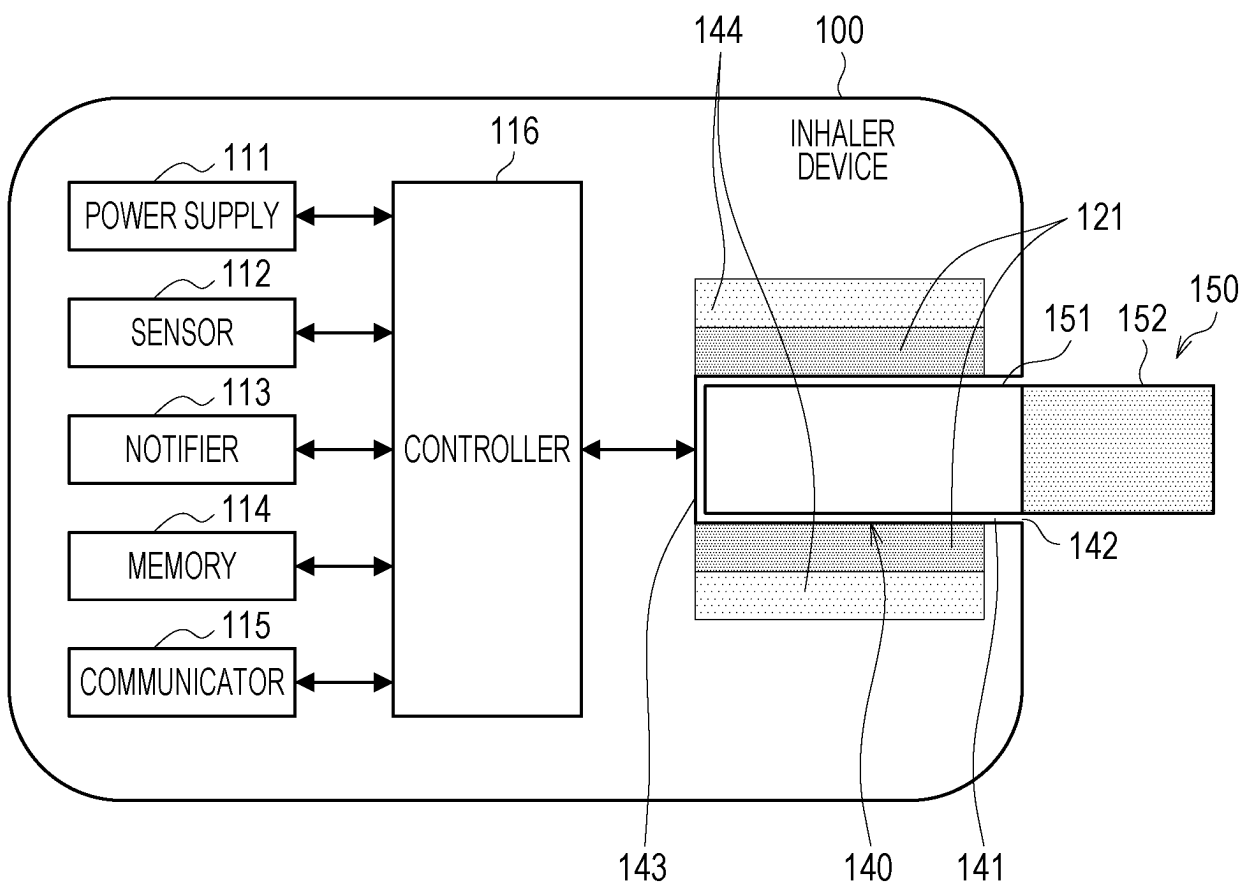

FIG. 2

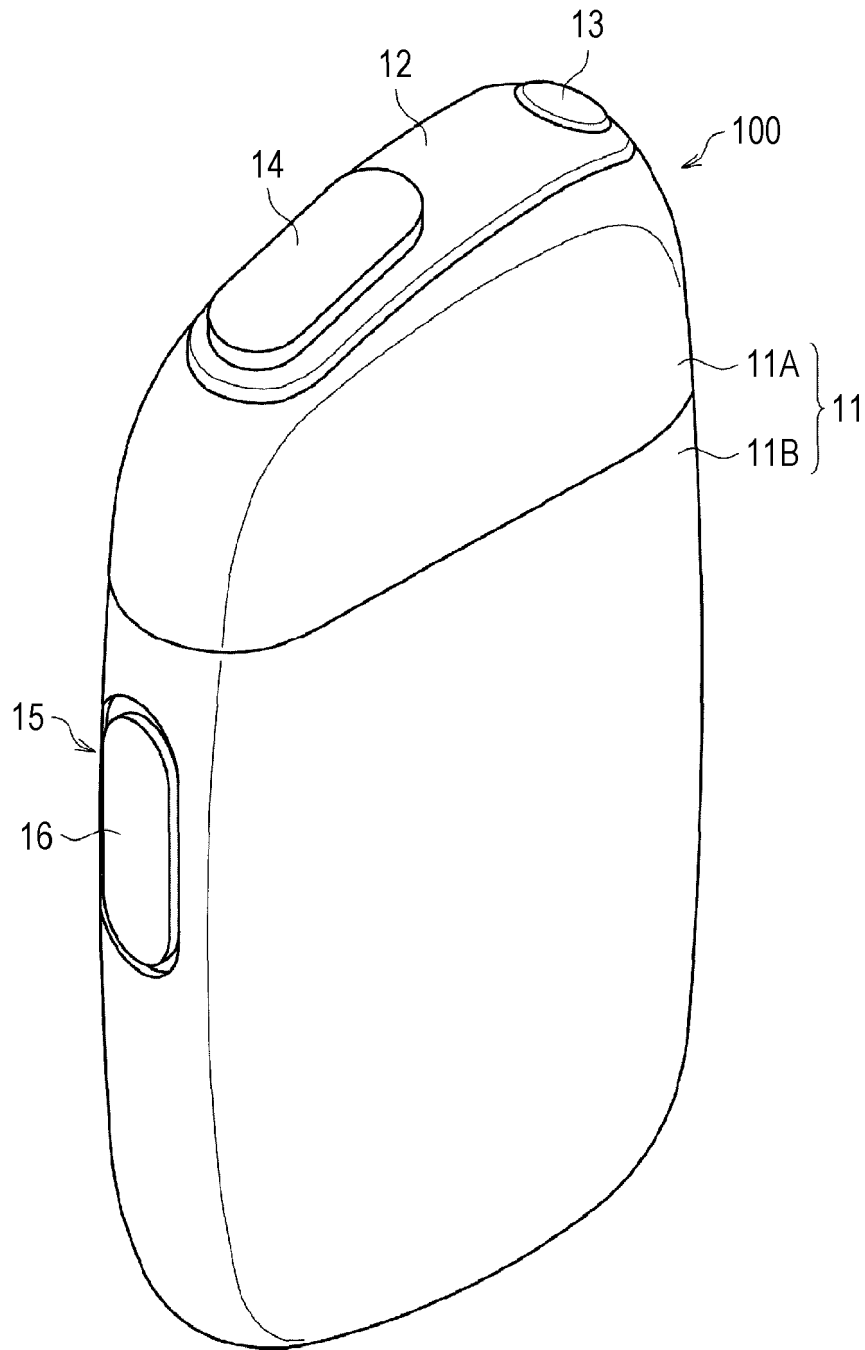

FIG. 3

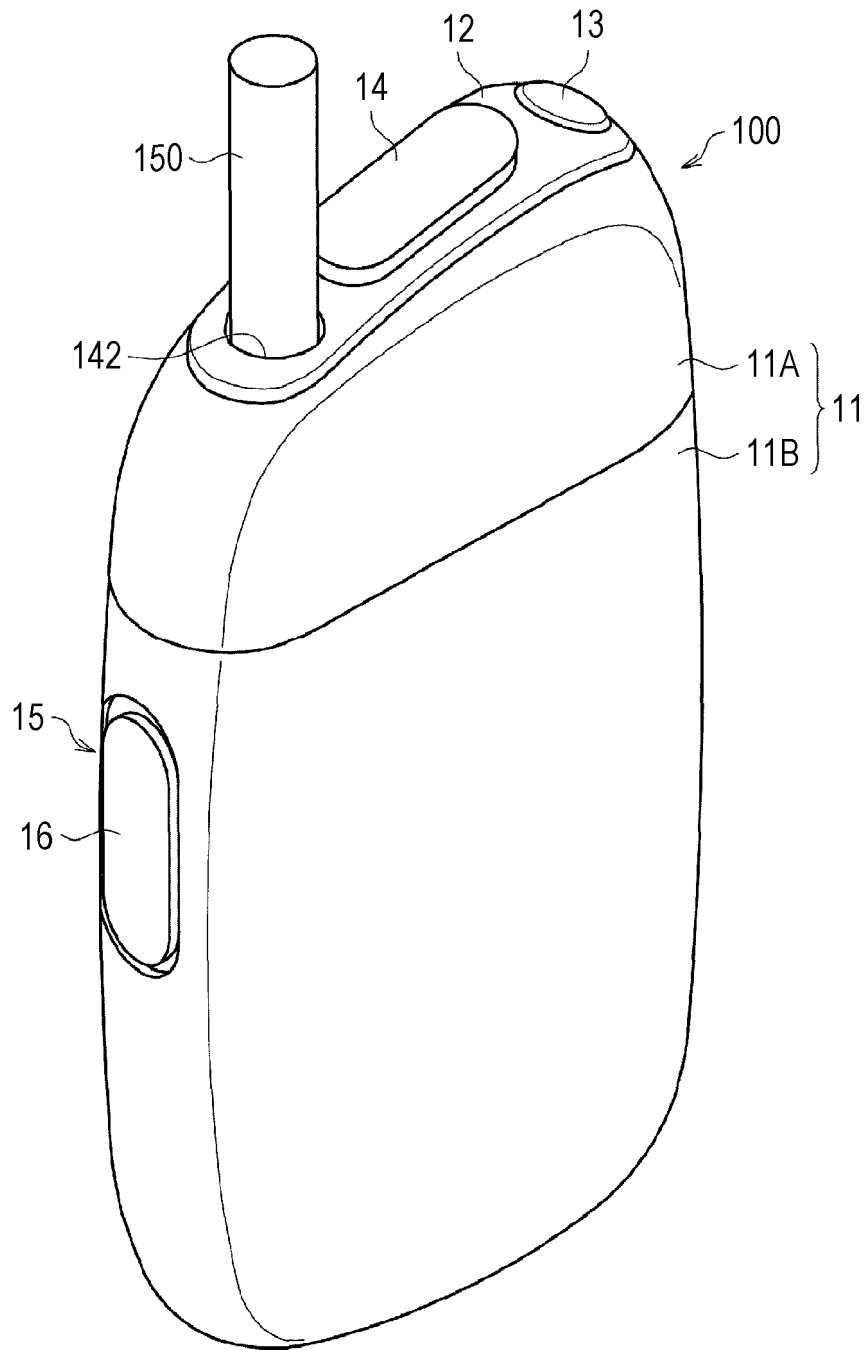

FIG. 4

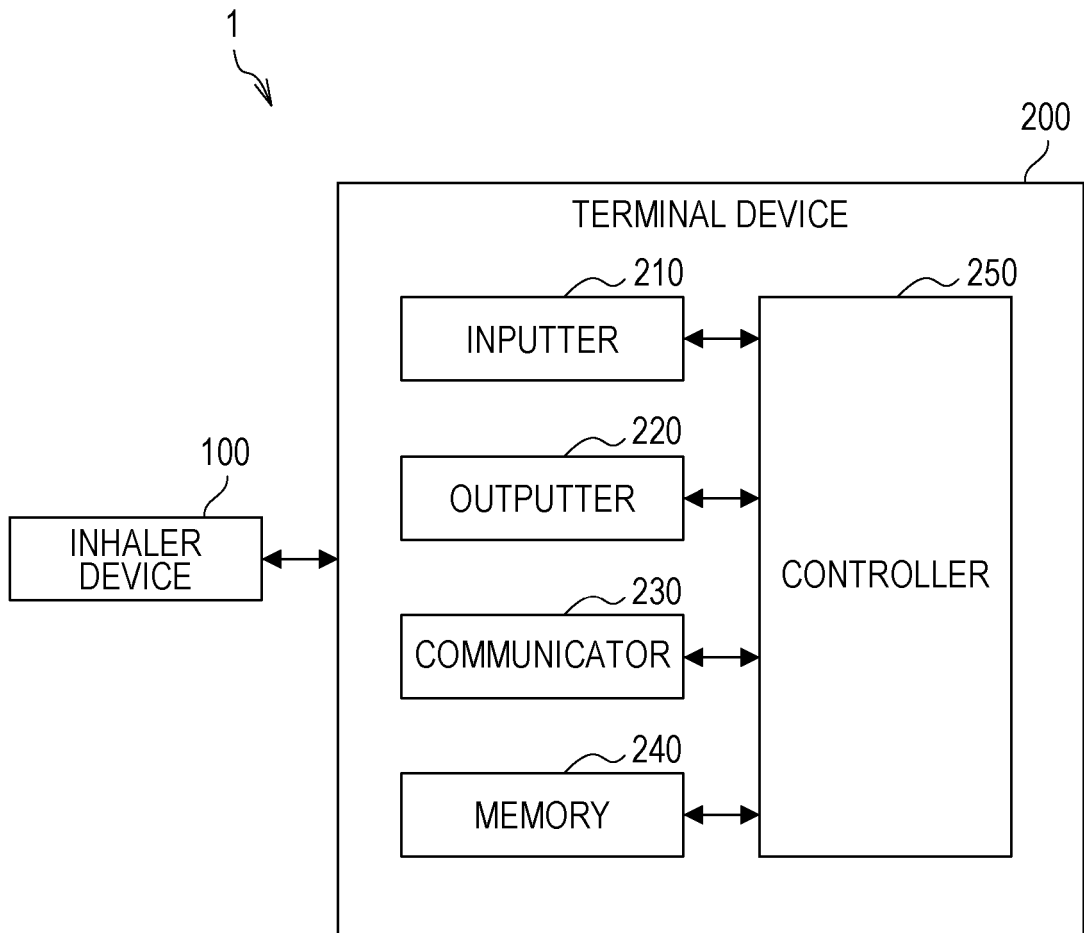

FIG. 5

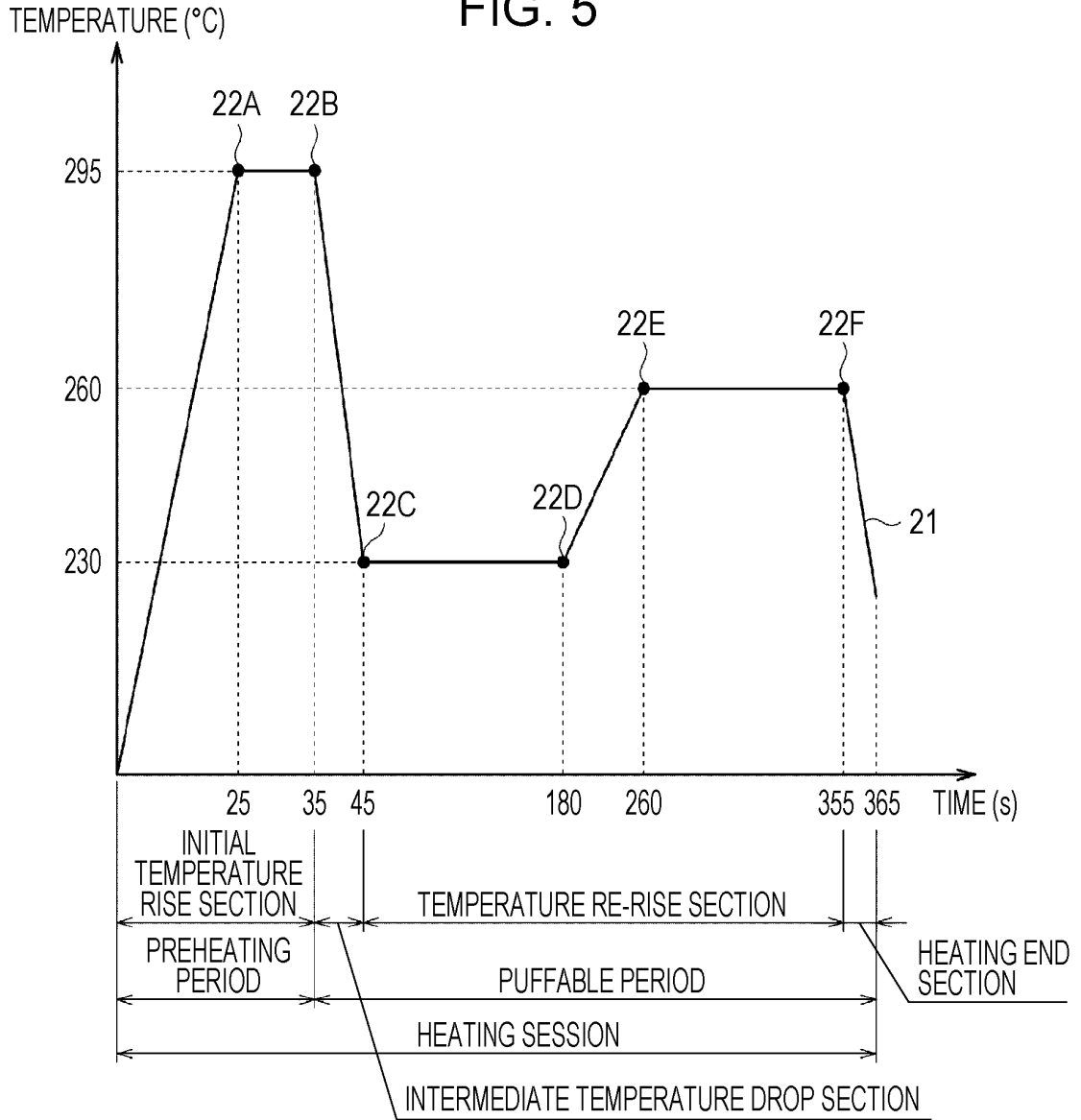

FIG. 6

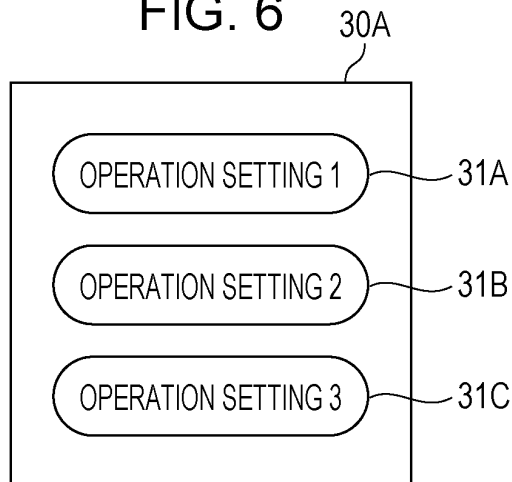

FIG. 7

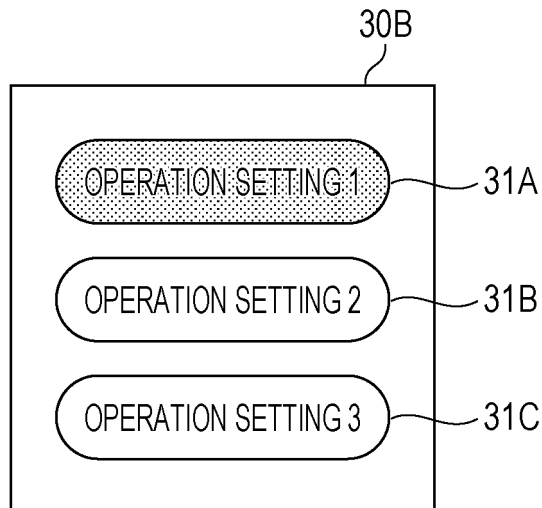

FIG. 8

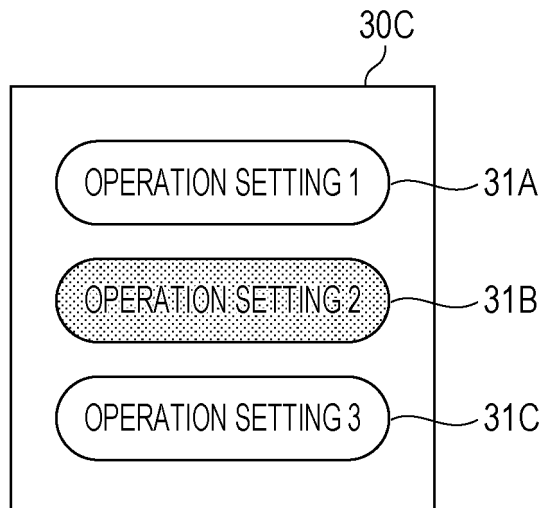

FIG. 9

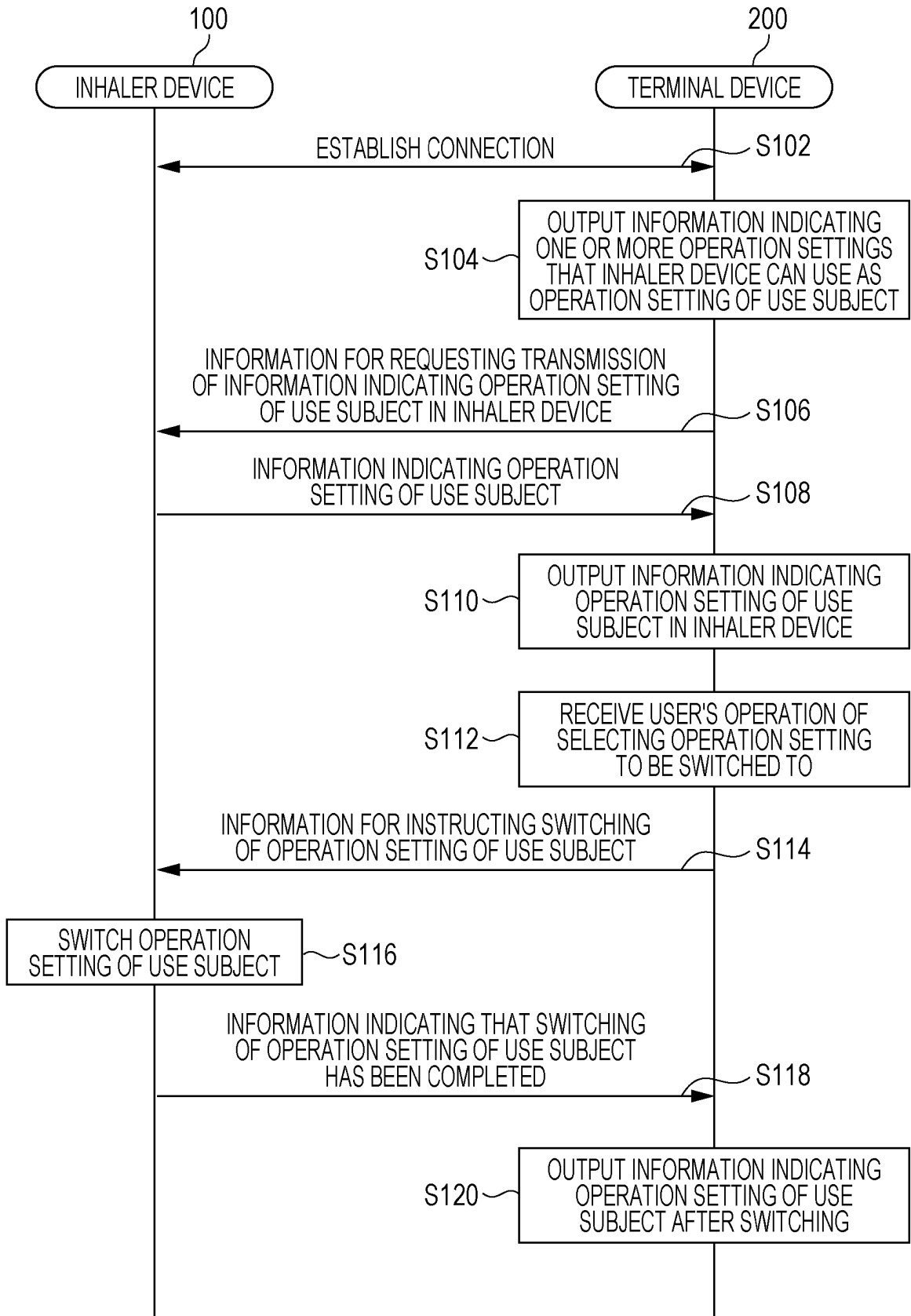

FIG. 10

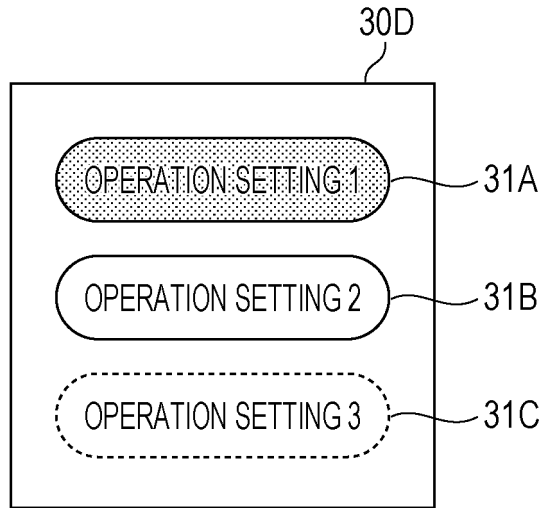

FIG. 11

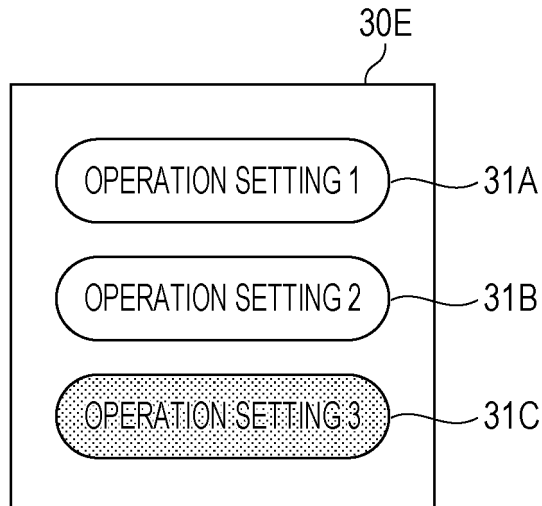
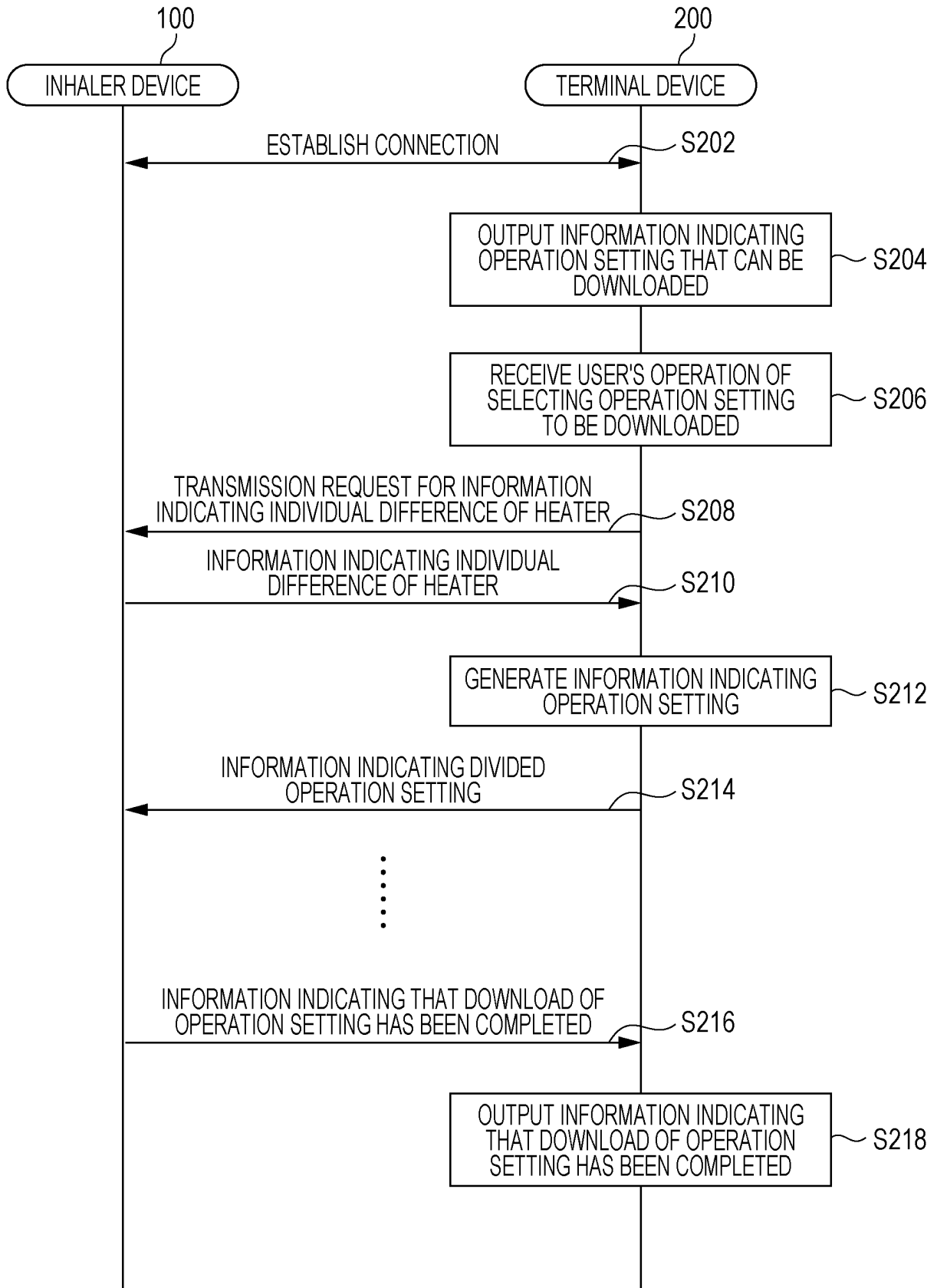

FIG. 12



INTERNATIONAL SEARCH REPORT

International application No.

PCT/JP2020/047335

A. CLASSIFICATION OF SUBJECT MATTER

A24F 40/57 (2020.01) i; A24F 40/65 (2020.01) i
 FI: A24F40/65; A24F40/57

According to International Patent Classification (IPC) or to both national classification and IPC

B. FIELDS SEARCHED

Minimum documentation searched (classification system followed by classification symbols)
 A24F40/57; A24F40/65

Documentation searched other than minimum documentation to the extent that such documents are included in the fields searched

Published examined utility model applications of Japan	1922-1996
Published unexamined utility model applications of Japan	1971-2021
Registered utility model specifications of Japan	1996-2021
Published registered utility model applications of Japan	1994-2021

Electronic data base consulted during the international search (name of data base and, where practicable, search terms used)

C. DOCUMENTS CONSIDERED TO BE RELEVANT

Category*	Citation of document, with indication, where appropriate, of the relevant passages	Relevant to claim No.
Y A	US 2020/0046033 A1 (PHILIP MORRIS PRODUCTS S. A.) 13 February 2020 (2020-02-13) fig. 1-3, paragraph [0074]	1-5, 7-13, 20 6, 14-19
X Y A	US 2019/0289915 A1 (NATIONAL CONCESSIONS GROUP INC.) 26 September 2019 (2019-09-26) fig. 1-3, 11- 15, paragraphs [0039], [0043]-[0050], [0097]- [0103]	10, 13, 20 1-5, 7-13, 20 6, 14-19
Y	WO 2019/186148 A1 (NICOVENTURES TRADING LIMITED) 03 October 2019 (2019-10-03) fig. 3-4	8-9, 11-13
A	JP 2020-99345 A (RAI STRATEGIC HOLDINGS, INC.) 02 July 2020 (2020-07-02) paragraph [0114]	1-20



Further documents are listed in the continuation of Box C.



See patent family annex.

* Special categories of cited documents:

"A" document defining the general state of the art which is not considered to be of particular relevance

"E" earlier application or patent but published on or after the international filing date

"L" document which may throw doubts on priority claim(s) or which is cited to establish the publication date of another citation or other special reason (as specified)

"O" document referring to an oral disclosure, use, exhibition or other means

"P" document published prior to the international filing date but later than the priority date claimed

"T" later document published after the international filing date or priority date and not in conflict with the application but cited to understand the principle or theory underlying the invention

"X" document of particular relevance; the claimed invention cannot be considered novel or cannot be considered to involve an inventive step when the document is taken alone

"Y" document of particular relevance; the claimed invention cannot be considered to involve an inventive step when the document is combined with one or more other such documents, such combination being obvious to a person skilled in the art

"&" document member of the same patent family

Date of the actual completion of the international search
08 January 2021 (08.01.2021)

Date of mailing of the international search report
26 January 2021 (26.01.2021)

Name and mailing address of the ISA/
Japan Patent Office
3-4-3, Kasumigaseki, Chiyoda-ku,
Tokyo 100-8915, Japan

Authorized officer

Telephone No.

Form PCT/ISA/210 (second sheet) (January 2015)

INTERNATIONAL SEARCH REPORT
Information on patent family members

International application No. PCT/JP2020/047335
--

5	Patent Documents referred in the Report	Publication Date	Patent Family	Publication Date
	US 2020/0046033 A1	13 Feb. 2020	WO 2018/202403 A1 CN 110536617 A KR 10-2019-0140455 A	
10	US 2019/0289915 A1 WO 2019/186148 A1 JP 2020-99345 A	26 Sep. 2019 03 Oct. 2019 02 Jul. 2020	WO 2019/183537 A1 (Family: none) (Family: none)	
15				
20				
25				
30				
35				
40				
45				
50				
55				

Form PCT/ISA/210 (patent family annex) (January 2015)

REFERENCES CITED IN THE DESCRIPTION

This list of references cited by the applicant is for the reader's convenience only. It does not form part of the European patent document. Even though great care has been taken in compiling the references, errors or omissions cannot be excluded and the EPO disclaims all liability in this regard.

Patent documents cited in the description

- WO 2020019122 A1 [0004]