

(19)



(11)

EP 4 256 152 B1

(12)

EUROPEAN PATENT SPECIFICATION

(45) Date of publication and mention of the grant of the patent:
08.01.2025 Bulletin 2025/02

(51) International Patent Classification (IPC):
E04G 5/14 (2006.01) E04G 7/34 (2006.01)

(21) Application number: **21823386.4**

(52) Cooperative Patent Classification (CPC):
E04G 5/142; E04G 5/147; E04G 7/34

(22) Date of filing: **07.12.2021**

(86) International application number:
PCT/NL2021/050742

(87) International publication number:
WO 2022/124890 (16.06.2022 Gazette 2022/24)

(54) **RAIL ASSEMBLY FOR A SCAFFOLD, SCAFFOLD, SET OF SCAFFOLD PARTS, AND METHODS**

SCHIENENANORDNUNG FÜR EIN GERÜST, GERÜST, SATZ AUS GERÜSTTEILEN UND VERFAHREN

ENSEMBLE RAIL POUR UN ÉCHAFAUDAGE, ÉCHAFAUDAGE, ENSEMBLE DE PARTIES D'ÉCHAFAUDAGE, ET PROCÉDÉS

(84) Designated Contracting States:
AL AT BE BG CH CY CZ DE DK EE ES FI FR GB GR HR HU IE IS IT LI LT LU LV MC MK MT NL NO PL PT RO RS SE SI SK SM TR

(72) Inventor: **BUSSCHERS, Robert Christiaan**
6021 PZ Budel (NL)

(30) Priority: **07.12.2020 NL 2027056**

(74) Representative: **V.O.**
P.O. Box 87930
2508 DH Den Haag (NL)

(43) Date of publication of application:
11.10.2023 Bulletin 2023/41

(56) References cited:
WO-A1-02/077392 WO-A1-2020/192811
JP-A- 2005 188 275 JP-A- 2007 100 495
JP-A- 2010 242 419 US-A1- 2005 150 612

(73) Proprietor: **Scafom Holding B.V.**
6021 PZ Budel (NL)

EP 4 256 152 B1

Note: Within nine months of the publication of the mention of the grant of the European patent in the European Patent Bulletin, any person may give notice to the European Patent Office of opposition to that patent, in accordance with the Implementing Regulations. Notice of opposition shall not be deemed to have been filed until the opposition fee has been paid. (Art. 99(1) European Patent Convention).

Description

FIELD

[0001] The invention relates to a rail assembly for a scaffold as well as to a scaffold provided with the rail assembly. The invention further relates to a set of scaffold parts, a method for providing a rail on a scaffold, and a method for augmenting passability of a scaffold.

BACKGROUND

[0002] A rail assembly for a scaffold is known as such in diverse variants. A known rail assembly can be coupled from a first scaffold level to the scaffold to furnish a rail for a second scaffold level, which is for instance still under construction. A rail thus coupled to the scaffold can reduce a risk of falling for staff present on the second level.

[0003] Safety and efficiency of coupling known rail assemblies to the scaffold is rendered more difficult in that the assemblies are relatively large. Staff that has to bring the assembly to the place of coupling needs to guide the assembly safely along other scaffold parts such as standards. Moreover, upon arrival at the place of coupling, the available work space often proves limited due to the scaffold construction present and any further obstacles such as a building. The large size of the known rail assemblies further has as a disadvantage that storage and transport thereof is relatively costly.

[0004] WO 02/077392 A1, JP 2005 188275 A and WO 2020/192811 A1 each disclose a rail assembly for a scaffold, the assembly comprising an upper rail unit and a middle rail unit which are both hingedly connected with two standard parts and which are both telescopic to be able to move the standard parts relative to each other. JP 2007 100495 A and JP 2010 242419 A each disclose a rail assembly comprising a non-telescopic upper rail unit and a telescopic middle rail unit.

SUMMARY

[0005] An object of the invention is to provide a rail assembly that is easier to place. Further objects are to improve fall protection at scaffolds and to make scaffold erection more efficient.

[0006] To this end, the invention provides a rail assembly according to claim 1. The rail assembly comprises a first standard part and a second standard part.

[0007] The rail assembly comprises an upper rail unit which at a first hinge position is hingedly connected with the first standard part and at a second hinge position is hingedly connected with the second standard part.

[0008] The rail assembly comprises a middle rail unit which at a third hinge position is hingedly connected with the first standard part and at a fourth hinge position is hingedly connected with the second standard part.

[0009] The rail assembly is provided with coupling means which are configured to couple the rail assembly

fixingly to the scaffold.

[0010] Fixingly coupling to the scaffold is understood to mean that the coupling substantially counteracts the assembly, in particular the rail units thereof, being able to move relative to the scaffold. In other words, the coupling to the scaffold is preferably a non-rotation and non-translation coupling by which the rail assembly in its rail forming configuration is retained on the scaffold. For that matter, the coupling means, at least a part thereof, are preferably also configured to couple the rail assembly, if so desired, non-fixingly to the scaffold, as is further explained elsewhere in this description.

[0011] The coupling means, at least a part thereof, are preferably provided on the standard parts at a distance from the rail units. Alternatively or additionally, the coupling means or parts thereof may be provided near the rail units.

[0012] The rail assembly is configured to be adjusted by hinging at the hinge positions mentioned between on the one hand a rail forming configuration, in which the upper rail unit and the middle rail unit can respectively form an upper rail and a middle rail for the scaffold, at least when the rail assembly is fixingly coupled to the scaffold, and on the other hand a transport configuration which is more compact compared with the rail forming configuration.

[0013] Due to the hinging, the rail assembly in the transport configuration can in particular be relatively narrow vis-à-vis the rail forming configuration, while the rail assembly in the transport configuration can be more elongate vis-à-vis the rail forming configuration.

[0014] One of the upper rail unit and the middle rail unit is telescopic to enable varying a distance between the respective hinge positions of the one rail unit, at least when at most one of the first standard part and the second standard part is coupled to the scaffold.

[0015] The one telescopic rail unit makes it possible that the rail assembly in the transport configuration has relatively particularly small dimensions, while the narrowing because of the hinging can entail only little or no lengthening (i.e., in the length direction of the then relatively elongate assembly).

[0016] In particular, it is thus made possible that both standard parts in the transport configuration extend substantially along, for instance substantially parallel to, the rail units, as a consequence of which the assembly in that configuration can have a length that substantially corresponds to a length of a rail unit, at least a length that is appreciably less than a sum of the length of a rail unit and a length of a standard part.

[0017] When the rail assembly in the rail forming configuration is coupled to the scaffold, telescoping of the telescopic rail unit may be directly or indirectly blocked, so that a relatively strong rail construction is formed which provides a proper fall protection.

[0018] The rail assembly according to the invention is thus easy to place. It is thereby made possible to provide proper fall protection to a scaffold in a more efficient man-

ner.

[0019] The other of the upper rail unit and the middle rail unit is non-telescopable. Thus, the rail assembly can be particularly strong and stable in its rail forming configuration. Moreover, the rail assembly can thus be particularly light-weight.

[0020] A further aspect of the invention provides a scaffold comprising at least one rail assembly as herein described.

[0021] Preferably, the rail assembly is coupled to the scaffold by means of the coupling means.

[0022] Such a scaffold provides the above-mentioned advantages.

[0023] A further aspect provides a set of scaffold parts for forming a scaffold, comprising a plurality of scaffold parts and at least one rail assembly as herein described.

[0024] Preferably, at least one of the scaffold parts is suitable for coupling the rail assembly thereto by means of the coupling means. The at least one scaffold part concerns for instance a standard, such as a substantially tube-shaped standard, or for instance a frame which comprises or can form such a standard.

[0025] Such a set provides the above-mentioned advantages.

[0026] A further aspect provides a method for providing a rail on a scaffold according to claim 14.

[0027] The method comprises: providing a rail assembly herein described; and coupling the rail assembly to the scaffold at one of the first standard part and the second standard part. The method comprises further: moving the other standard part away from the one standard part, as a result of which one of the upper rail unit and the middle rail unit is telescoped, and the rail units are hinged relative to the standard parts; and coupling the rail assembly to the scaffold at the other standard part, resulting in the rail assembly in its rail forming configuration being fixingly coupled to the scaffold.

[0028] Such a method provides the above-mentioned advantages.

[0029] A further aspect provides a method for augmenting the passability of a scaffold according to claim 15, which includes a rail assembly as herein described. This method comprises: during use of the scaffold, detaching the rail assembly from the scaffold at one of the first standard part and the second standard part while the rail assembly at the other standard part remains coupled to the scaffold; and moving the one standard part towards the other standard part, as a result of which one of the upper rail unit and the middle rail unit is telescoped, and the rail units are hinged relative to the standard parts.

[0030] With such a method, the passability of the scaffold during use can be easily and efficiently adjusted to the activities to be carried out at the scaffold. In particular, the passability in the rail forming configuration of the rail assembly can be kept relatively small to provide fall security. When desired, the passability can be easily augmented by bringing the rail assembly out of its rail forming configuration, to be able then to displace a relatively large

object through the scaffold. When the greater passability is not desired anymore, the earlier fall security can be easily restored by moving one standard part away from the other standard part again and then to couple the rail assembly completely to the scaffold again.

DETAILED DESCRIPTION

[0031] In the following, the invention will be further explained on the basis of examples of embodiments and drawings. The drawings are schematic and merely show examples. In the drawings, like or corresponding elements are provided with like or corresponding reference signs.

[0032] In the drawings:

Fig. 1 shows a schematic isometric front view of an example of a scaffold with a rail assembly coupled thereto according to a first embodiment, wherein the rail assembly is in the rail forming configuration;

Fig. 2 shows a schematic front view of an example of a rail assembly according to a second embodiment, wherein the rail assembly is in the rail forming configuration;

Fig. 3 shows a schematic isometric front view of the scaffold with rail assembly of Fig. 1, wherein the rail assembly is in the transport configuration;

Fig. 4 shows a schematic front view of the rail assembly of Fig. 2, wherein the rail assembly is in the transport configuration;

Fig. 5A shows an isometric view of an example of a rail assembly according to the first embodiment, wherein the rail assembly is in the transport configuration;

Fig. 5B shows an isometric view of the rail assembly of Fig. 5A, wherein the rail assembly is in an intermediate configuration;

Fig. 5C shows an isometric view of the rail assembly of Figs. 5A-B, wherein the rail assembly is in the rail forming configuration;

Fig. 6A shows an isometric view of an example of a rail assembly according to the second embodiment, wherein the rail assembly is in the transport configuration;

Fig. 6B shows an isometric view of the rail assembly of Fig. 6A, wherein the rail assembly is in an intermediate configuration; and

Fig. 6C shows an isometric view of the rail assembly of Figs. 6A-B, wherein the rail assembly is in the rail forming configuration.

[0033] The drawings show examples of a rail assembly 2, 102 for a scaffold 4. The rail assembly 2, 102 comprises a first standard part 6 and a second standard part 8. The assembly 2, 102 comprises an upper rail unit 14 which at a first hinge position S1 is hingedly connected with the first standard part 6 and at a second hinge position S2 is hingedly connected with the second standard part 8.

The assembly 2, 102 comprises a middle rail unit 16 which in a third hinge position S3 is hingedly connected with the first standard part 6 and at a fourth hinge position S4 is hingedly connected with the second standard part 8.

[0034] The rail assembly 2, 102 comprises coupling means 10, 12 which are configured to couple the rail assembly 2, 102 fixingly to the scaffold 4.

[0035] The rail assembly 2, 102 is configured to be adjusted by hinging at the hinge positions S1, S2, S3, S4 between on the one hand a rail forming configuration CL (see Figs. 1, 2, 5C, 6C), in which the upper rail unit 14 and the middle rail unit 16 respectively can form an upper rail unit and a middle rail unit for the scaffold 4, at least when the rail assembly 2, 102 is fixingly coupled to the scaffold 4, and on the other hand a transport configuration CT, which is more compact compared with the rail forming configuration CL (see Figs. 3, 4, 5A, 6A).

[0036] One of the upper rail unit 14 and the middle rail unit 16 is telescopic to enable varying of a distance D1 or D2 between the respective hinge positions S1, S2 or S3, S4 of the rail unit 14 or 16, at least when at most one of the first standard part 6 and the second standard part 8 is coupled to the scaffold 4. The other one of the upper rail unit 14 and the middle rail unit 16 is non-telescopic, as is further explained elsewhere in this description.

[0037] In the examples shown, the scaffold 4 comprises different scaffold parts, including standards 4a1, 4a2, ledgers 4b and working platforms 4c which are mutually coupled by coupling means suitable therefor, such as XYZ couplings. Such scaffold parts and coupling means are known per se for forming a scaffold 4. The scaffold 4 preferably provides several work levels N1, N2 above one another. The rail assembly 2, 102 is preferably configured such, and/or is preferably used in a manner such, that from a first work level N1 by coupling of the assembly 2, 102 to the scaffold 4, a scaffold rail for a second work level N2 located above is formed. Thus, for the second work level N2 fall protection can already be provided before the work level N2 is in actual fact entered. It will be clear that such a method can be repeated for further work levels of the scaffold 4. Moreover, depending on a width of the scaffold 4 with respect to the rail assembly 2, 102, for a same work level several rail assemblies 2, 102 can be arranged next to each other. Solely for the purpose of not making the drawings unnecessarily complex, only one rail assembly 2, 102 per scaffold 4 is shown in them.

[0038] In an embodiment, the first standard part 6 and the second standard part 8 in the rail forming configuration CL extend each substantially at an angle with respect to at least one of the upper rail unit 14 and the middle rail unit 16, wherein the first standard part 6, the second standard part 8, the upper rail unit 14 and the middle rail unit 16 in the transport configuration CT extend substantially parallel to each other.

[0039] In Fig. 5A, it can be seen, as an example, that in the transport configuration CT nonetheless a small angle (of for instance at most 20, 15 or 10 degrees) may

be included between main directions of two or more of the parts mentioned, in this case for instance between a standard part 6 on the one hand and the rail units 14, 16 on the other hand. Such an angle between another standard part 8 and the rail units 14, 16 can for instance be the same or smaller or be absent. Thus, if desired, in the transport configuration CT a partly or wholly butterfly-shaped configuration can be obtained, which can for instance facilitate the attachment of the assembly 2 to the scaffold 4 as well as the compact stacking of a plurality of such assemblies 2. Moreover, in this way, as far as necessary, depending on ratios of dimensions of the assembly 2, the standard parts 6, 8 touching and/or blocking each other in the transport configuration CT can be counteracted.

[0040] In the examples shown, the rail units 14, 16 extend in the rail forming configuration CL substantially at right angles relative to the standard parts 6, 8, so that a substantially rectangular rail frame is formed, while a substantially rectangular intermediate space is enclosed between the rail units 14, 16 and the standard parts 6, 8. It will be clear that alternatively or additionally, other shapes than rectangular ones are possible.

[0041] Thus, the rail assembly 2, 102 in the rail forming configuration CL can provide fall protection over a relatively large surface, while the assembly 2, 102 in the transport configuration CT is relatively compact and thereby more easily transportable. This concerns both transport from and to the scaffold location and transport at and through the scaffold 4 itself. This last can for instance be relatively easily carried out by a single person.

[0042] During use of the rail assembly 2, 102, preferably, additionally fall protection is provided by a toe board, not shown, which can for instance be of a type known per se. Such a toe board extends preferably parallel to a work floor 4c of the scaffold 4 and in mounted position has a defined height, for instance at least 150 mm. For a particularly good fall protection, the rail assembly 2, 102 is preferably placed such that a distance between the middle rail unit 16 and an upper edge of the toe board is 470 mm at a maximum. At the same time, it may be desirable for achieving a compact transport configuration CT to let a distance between the middle rail unit 16 and the upper rail unit 14 in the rail forming configuration CL be relatively small. To this end, a permitted distance between toe board and middle rail unit 16 is preferably utilized to a large extent. This is to say, for instance, that the rail assembly 2, 102 is configured such that during use the distance between the toe board and the middle rail unit 16 is not greater but neither much smaller than a permitted maximum distance of for instance 470 mm.

[0043] In an embodiment, in the transport configuration CT, compared with the rail forming configuration CL, the first standard part 6 and the second standard part 8 are mutually rotated through more than 90 degrees about an imaginary axis X which extends perpendicular to a plane in which the rail assembly 2, 102 substantially extends, preferably rotated more than 120 degrees, more prefer-

ably rotated more than 150 degrees, for instance rotated circa 180 degrees.

[0044] In Figs. 1, 3, 5C and 6C the imaginary axis X is roughly indicated. In the examples shown, the standard parts 6, 8 in the different configurations CT, CL have been rotated relative to each other about the axis X about 180 degrees.

[0045] Thus, it is made possible for both standard parts 6, 8 in the transport configuration CT to extend along the rail units 14, 16, so that the assembly 2, 102 in that configuration CT can have a length that substantially corresponds to a length of a rail unit 14 or 16, at least, a length that is appreciably smaller than a sum of the length of a rail unit 14 or 16 and a length of a standard part 6 or 8.

[0046] In an embodiment, a portion of the middle rail unit 16 extends in the transport configuration CT between the upper rail unit 14 and the first standard part 6, and a further portion of the middle rail unit 16 extends in the transport configuration CT between the upper rail unit 14 and the second standard part 8.

[0047] Thus, the transport configuration can be particularly compact, while the standard parts 6, 8 in the transport configuration CT can for instance be substantially in line with each other along the middle rail unit 16.

[0048] In an embodiment, for instance the first embodiment (see Figs. 1, 3, 5A-C), the first and second hinge positions S1, S2 are positioned offset with respect to a line L1 along which the upper rail unit 14 substantially extends or with respect to a line L2, L3 in which the respective standard part 6, 8 substantially extends, so that in the transport configuration CT between the upper rail unit 14 and the standard parts 6, 8 an intermediate space 18 is formed in which the middle rail unit 16 extends.

[0049] Thus, a compact transport configuration CT is achieved while for the parts of the assembly 2, 102 yet sufficient space is available to have them extend substantially parallel to each other along each other.

[0050] In an embodiment, the rail assembly 2, 102 is provided at at least one of the hinge positions S1, S2, S3, S4 with a hinge stop to limit a mutual hinging of mutually hingeable parts 6, 8, 14, 16 of the assembly 2, 102 to counteract that hingeable parts 6, 8, 14, 16 of the assembly 2, 102 can be hinged at the respective hinge positions S1, S2, S3, S4 from the transport configuration CT to beyond the rail forming configuration CL.

[0051] Preferably, such a hinge stop is provided at each of the hinge positions S1, S2, S3, S4. Such a hinge stop can for instance be formed by respective stop parts of the respective hingeable parts 6, 8, 14, 16.

[0052] With such a hinge stop a particularly strong rail forming configuration CL can be achieved, which is of benefit to the fall protection function of the assembly 2, 102. In particular, it can thereby be effected that in the rail forming configuration CL any play in the hinge positions S1, S2, S3, S4 is eliminated in that the hinge positions S1, S2, S3, S4 have run against their hinge stops. Moreover, in this manner, coupling the assembly 2, 102 to the scaffold 4 is further facilitated, because the hinge

stop automatically prevents the assembly 2, 102 being folded out too far.

[0053] In an embodiment, mutually telescopic parts 14a, 14b or 16a, 16b are provided with one or more telescoping stops to counteract that the parts can be telescoped in one or more directions too far, for instance beyond the rail forming configuration CL and/or beyond the transport configuration CT.

[0054] In an embodiment, the rail assembly 2, 102 is dimensioned so as in the rail forming configuration CL, by coupling of the assembly 2, 102 to the scaffold 4, to provide to at least one of the hinging parts 6, 8, 14, 16 a bias in the direction of the hinge stop, so that a substantially play-free configuration is created.

[0055] When the respective hinging part has some (bending) elasticity, as with an elongate steel part, the bias may for instance be furnished by that elasticity. The assembly 2, 102 may for instance be so dimensioned that complete coupling of the assembly 2, 102 to the scaffold 4 is only possible when an elastic part concerned is brought slightly to a (bending) tension, for instance by a manual slightly forceful pulling of the hinging assembly 2, 102. To that end, for instance, one or more of the rail units 14, 16 may, relative to a no-tension configuration, be somewhat shortened or lengthened in dimensioning.

[0056] In an embodiment, to this end, a non-telescopic rail unit (for instance the upper rail unit 14 of assembly 2 or the middle rail unit 16 of assembly 102) is slightly shortened in dimensioning relative to a tensionless configuration, so that at the hinge positions S1, S2, S3, S4 a bias in the direction of the respective stop arises when the assembly 2, 102 is completely coupled to the scaffold 4.

[0057] In an embodiment, the rail assembly 2, 102 is configured to selectively counteract the assembly 2, 102 being brought out of its transport configuration CT.

[0058] Thus, the assembly 2, 102 can particularly easily and safely be transported with relatively little risk of the parts of the assembly 2, 102 moving unintendedly out of the transport configuration CT.

[0059] Such selective counteracting can, during use, preferably be cancelled by a person who couples the rail assembly 2, 102 to the scaffold 4, for instance when or after the assembly 2, 102 is partly coupled to the scaffold 4.

[0060] In an embodiment, the arrangement of the rail assembly 2, 102 to selectively counteract the assembly 2, 102 being brought out of its transport configuration CT is realized by the coupling means 10, 12.

[0061] Thus, placement of the rail assembly 2, 102 on a scaffold 4 is further facilitated.

[0062] In the examples of Figs. 5A-C and 6A-C it is shown that the coupling means 10, 12 to that end comprise, on a side located with respect to the standard part 6, 8 opposite a scaffold coupling side, a respective clamping means 10c, 12c which in the transport configuration CT can clampingly engage the middle rail unit 16. The clamping engagement can, if desired, be cancelled, for

instance by a slightly forceful manually pulling apart of two or more parts of the assembly and/or by a manual operation of the coupling means 10, 12.

[0063] In an embodiment, the coupling means 10, 12 are configured to couple at least one of the standard parts 8 to the scaffold 4 such that the at least one standard part 8 is detachable from the scaffold 4 without detaching parts of the scaffold 4 itself from each other.

[0064] Advantageously, the rail forming configuration CL of the assembly 2, 102 can thus, if desired, be easily and rapidly cancelled, for instance temporarily, while the scaffold 4 itself can remain functional and intact. This may for instance be desired when a relatively large object is to be passed through the scaffold 4, for instance into or out of an adjacent building. When this is desired, the rail forming configuration CL can subsequently be easily and rapidly restored by coupling the detached standard part 8 to the scaffold 4 anew, so that again a good fall protection is provided.

[0065] In the examples shown, the detachability mentioned is achieved in that the coupling means 12 of one 8 of the standard parts are substantially formed by forks, for instance in contrast to the eye 20 which is provided in the coupling means 10 of the other standard part 6 and which is further explained elsewhere in this description.

[0066] In an embodiment, the coupling means 10, 12 are configured to engage, at each of the standard parts 6, 8, the scaffold 4 at at least two mutually different positions 10a, 10b, 12a, 12b.

[0067] The at least two mutually different positions 10a, 10b, 12a, 12b are preferably provided in a length direction of the standard parts 6, 8 at a distance from each other. Thus, rotation of the standard parts 6, 8 relative to the scaffold 4 can at least partly be counteracted, in particular rotation about an axis which extends at an angle to the standard part 6, 8. It will be clear that the rail assembly 2, 102 can be configured to engage, at one or each of the standard parts 6, 8, the scaffold 4 at more than two mutually different positions, for instance when the scaffold 4 has been built up further after the rail assembly 2, 102 was coupled to the scaffold 4.

[0068] In an embodiment, the coupling means 10 comprise at least one eye 20 to secure the assembly 2, 102 to the scaffold 4.

[0069] Because such an eye 20 is generally detachable from the scaffold 4 only during assembly and disassembly of the scaffold, thus a proper protection is provided against the assembly 2 unintentionally coming completely loose from the scaffold 4. When coupling means 12 of the other standard part 8 are configured to be detachable from the scaffold 4 when the scaffold has been erected and is in use, nonetheless the passability of the scaffold 4 can be adjusted as desired, as explained elsewhere in this description.

[0070] The coupling means 10, 12 are preferably configured to clampingly engage a standard 4a1, 4a2 of the scaffold 4. Thus, mutual movement between the rail assembly 2, 102 and the standard 4a1, 4a2, in particular

along the standard 4a1, 4a2 and/or radially relative to the standard 4a1, 4a2, can be counteracted.

[0071] A further degree of freedom of mutual movement, viz. rotation about the centerline of the standard 4a1, 4a2, is counteracted in the examples shown when the assembly 2, 102 is coupled to a respective standard 4a1, 4a2 at both standard parts 6, 8. When the assembly 2, 102 is only coupled at one of the standard parts 6 to a standard 4a1, then, as regards the above-mentioned further degree of freedom, advantageously some play can be provided, as is further explained elsewhere in this description. Such play can make it possible to move parts of the rail assembly 2, 102 along scaffold parts such as ledgers 4b when the assembly 2, 102 is partly coupled to the scaffold 4. Thus, the rail assembly 2, 102, at least when not completely coupled to the scaffold 4, can extend partly within the plane of the respective standards and ledgers 4a1, 4a2, 4b of the scaffold 4 and partly outside that plane, as schematically shown in Fig. 3.

[0072] The coupling means 10, 20, for instance an eye 20 and/or one or more forks thereof, are preferably configured, for instance dimensioned, to rest on a support structure such as a circumferential widening of a standard 4a1, 4a2 of the scaffold 4. Thus, the rail assembly 2, 102 is effectively supported during use and it is (further) counteracted that the assembly might come down along the scaffold 4, unexpectedly, for instance when the assembly 2, 102 is loaded as a rail.

[0073] In an embodiment, (see Figs. 1-4, 5A-C, 6-C) the coupling means 10, 12 are provided at a distance from the rail units 14, 16. Alternatively or additionally, coupling means or parts thereof can be provided near the rail units, for instance on a rail unit itself or near a rail unit on a standard part.

[0074] Such a rail assembly 2, 102 can advantageously be stably coupled to the scaffold 4 even before a standard 4a1, 4a2 of the scaffold has been built up at the desired height of the rail units 14, 16.

[0075] In an embodiment, at least a part of the coupling means 10, 12 is provided on at least one of the standard parts 6, 8, to hinge along with the standard part 6, 8 relative to at least one of the rail units 16, 18.

[0076] In the examples of Figs. 1-6C the coupling means 10, 12 are provided on the standard parts 6, 8 at a distance from the rail units 14, 16.

[0077] In an embodiment (see Figs. 1, 3, 5A-C), the middle rail unit 16 is telescopic to be able to vary a distance D2 (see Figs. 1 and 3) between the third hinge position S3 and the fourth hinge position S4.

[0078] In an embodiment (see Figs. 1, 3, 5A-C), the upper rail unit 14 defines a fixed distance D1 between the first hinge position S1 and the second hinge position S2. To this end, the upper rail unit 14 in this embodiment is preferably non-telescopic.

[0079] In an embodiment (see Figs. 1, 3, 5A-C), the middle rail unit 16 comprises a first middle rail part 16a and a second middle rail part 16b, the middle rail parts 16a, 16b being connected with each other in a mutually

telescopic manner, wherein the first middle rail part 16a comprises the third hinge position S3, and the second middle rail part 16b comprises the fourth hinge position S4.

[0080] In an embodiment (see Figs. 1, 3, 5A-C), the distance D2 between the third hinge position S3 and the fourth hinge position S4, by telescoping of the middle rail unit 16, is smaller in the transport configuration CT than in the rail forming configuration CL.

[0081] Thus, a particularly light-weight and compactly transportable assembly 2 can be obtained, wherein in particular the upper rail unit 14 can be formed from relatively little material and wherein the assembly 2 in the transport configuration CT has substantially the length of the upper rail unit 14.

[0082] In an embodiment (see Figs. 1, 3, 5A-C), the first and second hinge positions S1, S2 in the rail forming configuration CL are located between a line L1 in which the upper rail unit 14 substantially extends, and a line L4 in which the middle rail unit 16 substantially extends.

[0083] Thus, the rail assembly 2 in the transport configuration CT can advantageously have substantially the length of the upper rail unit 14, while in that configuration CT parts of the rail assembly 2, 102 can extend substantially parallel to each other. The rail assembly 2, 102 is thus in the transport configuration CT both relatively short and relatively narrow.

[0084] In an embodiment (see Figs. 1, 3, 5A-C), the upper rail unit 14 comprises connecting parts 22, 24 which extend from a main part of the upper rail unit 14 radially outwards relative to a line L1 in which the upper rail unit 14 substantially extends, wherein the first and second hinge positions S1, S2 are provided on a respective one of the connecting parts 22, 24 at a distance from said line L1.

[0085] In the examples shown (see Figs. 1, 3, 5A-C), the connecting parts 22, 24 are formed by a respective tube part extending substantially perpendicularly radially outwards relative to the line L1 in which the upper rail unit substantially extends. The connecting parts 22, 24 thus extend in the rail forming configuration CL substantially in line with the respective standard part 6, 8.

[0086] In an embodiment, the middle rail unit 16 is telescopic over a telescoping distance that is at least as great as a sum $d(S1, S3) + d(S2, S4)$ of a distance $d(S1, S3)$ between the first and third hinge positions and a distance $d(S2, S4)$ between the second and fourth hinge positions. The mentioned distances between hinge positions are preferably measured parallel to the respective standard parts 6, 8.

[0087] In an embodiment (see Figs. 2, 4, 6A-C) the upper rail unit 14 is telescopic to be able to vary a distance D1 between the first hinge position S1 and the second hinge position S2.

[0088] In an embodiment (see Figs. 2, 4, 6A-C), the middle rail unit 16 defines a fixed distance D2 between the third hinge position S3 and the fourth hinge position S4. To this end, the middle rail unit 16 in this embodiment

is preferably non-telescopic.

[0089] In an embodiment (see Figs. 2, 4, 6A-C), the upper rail unit 14 comprises a first upper rail part 14a and a second upper rail part 14b, the upper rail parts 14a, 14b being connected with each other in a mutually telescopic manner, wherein the first upper rail part 14a comprises the first hinge position S1, and the second upper rail part 14b comprises the second hinge position S2.

[0090] In an embodiment (see Figs. 2, 4, 6A-C), the distance D1 between the first hinge position S1 and the second hinge position S2, by telescoping of the upper rail unit 14, is greater in the transport configuration CT than in the rail forming configuration CL.

[0091] Thus, a particularly strong rail assembly 102 can be obtained, wherein mutually telescoping upper rail parts 14a, 14b of the upper rail unit 14 reinforce each other (and thereby the assembly 102) in the rail forming configuration CL.

[0092] In an embodiment (see Figs. 2, 4, 6A-C), the first and second hinge positions S1, S2 are located on a line L1 in which the upper rail unit 14 substantially extends.

[0093] In an embodiment (see Figs. 2, 4, 6A-C), the first and second standard parts 6, 8 each comprise a connecting part 26, 28 which extends from a main part of the standard part 6, 8 radially outwards relative to a line L2, L3 in which the respective standard part 6, 8 substantially extends, wherein the first and second hinge positions S1, S2 are provided on the respective connecting part 26, 28 at a distance from said line L2, L3.

[0094] In the examples shown (see Figs. 2, 4, 6A-C), the connecting parts 26, 28 are formed by a respective tube part extending substantially perpendicularly radially outwards relative to the line L2 and L3, respectively, in which the standard part 6, 8 substantially extends. The connecting parts 26, 28 thus extend in the rail forming configuration CL substantially in line with the upper rail unit 14.

[0095] In an embodiment, the upper rail unit 14 is telescopic over a telescoping distance which is at least as great as a sum $d(S1, S3) + d(S2, S4)$ of a distance $d(S1, S3)$ between the first and third hinge positions and a distance $d(S2, S4)$ between the second and fourth hinge positions. The above distances between hinge positions are preferably measured parallel to the respective standard parts 6, 8.

[0096] In an embodiment, between the mutually telescopic parts 14a, 14b and/or 16a, 16b a guide means (not shown) is provided, such as a bush which is manufactured from a plastic, for example nylon.

[0097] With such a guide means, wear of the parts concerned is counteracted, and smooth telescoping is promoted.

[0098] In an embodiment, the rail assembly 2, 102 is, for instance at the coupling means 10 and/or 12, configured, after coupling of one of the standard parts 6 or 8 to the scaffold 4, to allow rotation of the other of the stand-

ard parts 8 or 6 about an imaginary rotation axis which extends near the one standard part 6 or 8 substantially parallel to that standard part 6 or 8.

[0099] Thus, a moving of parts of the rail assembly 2, 102 along parts such as ledgers 4b of the scaffold 4 is made easier, as explained elsewhere in this description.

[0100] The thus allowed rotation is preferably limited to an angular range of -30° through $+30^\circ$, more preferably a range of -15° through $+15^\circ$ relative to a coupling position of the standard part 8 or 6 on the scaffold 4. With such a limitation, the rail assembly 2, 102 rotating away dangerously and/or awkwardly far can be counteracted.

[0101] Figures 1 and 3 show an example of a scaffold 4 provided with at least one rail assembly 2, with the rail assembly 2 coupled to the scaffold 4 by means of the coupling means 10 and/or 12. It will be clear that a scaffold 4 may correspondingly be provided with a rail assembly 102 according to another embodiment. Moreover, in Figs. 5B-C and 6B-C one or more standards 4a1, 4a2 and a ledger 4b of such a scaffold 4 are schematically represented.

[0102] The scaffold 4 can for instance be wholly or partly built up from a set of scaffold parts 4a1, 4a2, 4b, 4c for forming a scaffold 4, the set comprising a plurality of scaffold parts and at least one rail assembly 2, 102, while at least one 4a1, 4a2 of the scaffold parts 4a1, 4a2, 4b, 4c is suitable to couple thereto the rail assembly 2, 102 by means of the coupling means 10, 12.

[0103] Alternatively or additionally, scaffold parts may be substantially fixedly connected, for instance welded, to each other. Standards 4a1, 4a2 may thus be provided as fixed part of a frame.

[0104] The scaffold 4 can for instance be a frame scaffold or a rolling scaffold.

[0105] With reference to the figures as illustration, a method for providing a rail on a scaffold 4 comprises: providing a rail assembly 2, 102; coupling the rail assembly 2, 102 to the scaffold 4 at one 6 of the first standard part 6 and the second standard part 8; moving away from the one standard part 6 the other standard part 8, resulting in one of the upper rail unit 14 and the middle rail unit 16 being telescoped, and the rail units 14, 16 being hinged relative to the standard parts 6, 8; and coupling the rail assembly 2, 102 to the scaffold 4 at the other standard part 8, resulting in the rail assembly 2, 102 in its rail forming configuration CL being fixingly coupled to the scaffold 4.

[0106] With reference to the figures as illustration, a method for augmenting passability of a scaffold 4 which is provided with a rail assembly 2, 102 comprises: during use of the scaffold 4, detaching the rail assembly 2, 102 from the scaffold 4 at one 8 of the first standard part 6 and the second standard part 8 while the rail assembly at the other standard part 6 remains coupled to the scaffold 4; and moving the one standard part 8 towards the other standard part 6, resulting in one of the upper rail unit 14 and the middle rail unit 16 being telescoped, and the rail units 14, 16 being hinged relative to the standard

parts 6, 8.

[0107] While the invention has been explained on the basis of examples of embodiments and drawings, these do not form any limitation of the invention, which is defined in the claims. It will be clear to the skilled person that many variations are possible. For instance, parts of a rail assembly may be tubular or non-tubular; a rail assembly may in addition to an upper rail unit and a middle rail unit have one or more further rail units which may or may not be telescopable; during use, a rail unit can extend differently than horizontally, for instance when a rail is provided for a work floor other than a horizontal one, as with a flight of stairs or a slope; a rail assembly may be couplable or be coupled to other scaffold parts than standards; a scaffold may be additionally provided with other rail assemblies or rails than a rail assembly according to the invention; a rail assembly according to the invention may be used as a so-called preceding rail and/or as a more permanent rail.

Claims

1. Rail assembly (2, 102) for a scaffold (4), comprising:

- a first standard part (6) and a second standard part (8);
- an upper rail unit (14) which at a first hinge position (S1) is hingedly connected with the first standard part (6) and at a second hinge position (S2) is hingedly connected with the second standard part (8); and
- a middle rail unit (16) which at a third hinge position (S3) is hingedly connected with the first standard part (6) and at a fourth hinge position (S4) is hingedly connected with the second standard part (8),

wherein the rail assembly (2, 102) is provided with coupling means (10, 12) which are configured to couple the rail assembly (2, 102) fixingly to the scaffold (4),

wherein the rail assembly (2, 102) is configured to be adjusted by hinging at said hinge positions (S1, S2, S3, S4) between on the one hand a rail forming configuration (CL), in which the upper rail unit (14) and the middle rail unit (16) respectively can form an upper rail and a middle rail for the scaffold (4), at least when the rail assembly (2, 102) is fixingly coupled to the scaffold (4), and on the other hand a transport configuration (CT), which is more compact compared with the rail forming configuration (CL),

wherein one of the upper rail unit (14) and the middle rail unit (16) is telescopable to enable varying of a distance (D1 or D2) between the respective hinge positions (S1,

- S2; or S3, S4) of the one rail assembly (14 or 16), at least when at most one of the first standard part (6) and the second standard part (8) is coupled to the scaffold (4), where-
 5 in the other of the upper rail unit (14) and the middle rail unit (16) is non-telescopable, **characterized in that**
 in the transport configuration (CT), compared with the rail forming configuration (CL), the first standard part (6) and the second standard part (8) are mutually rotated
 10 towards each other through more than 120 degrees, preferably more than 150 degrees, for example about 180 degrees, about an imaginary axis (X) which extends perpendicularly with respect to a plane in which the rail assembly (2, 102) substantially extends,
 15 and/or **in that**
 in the transport configuration (CT) both standard parts (6, 8) extend substantially along the rail units (14, 16), a portion of the middle rail unit (16) extends between the upper rail unit (14) and the first standard part (6), and a further portion of the middle rail unit (16) extends between the upper rail unit (14) and the second standard part (8).
 20
2. Rail assembly according to claim 1, wherein in the rail forming configuration (CL) the first standard part (6) and the second standard part (8) extend each substantially at an angle to at least one of the upper rail unit (14) and the middle rail unit (16),
 25 wherein in the transport configuration (CT) the first standard part (6), the second standard part (8), the upper rail unit (14) and the middle rail unit (16) extend substantially parallel to each other.
 30
3. Rail assembly according to any one of the preceding claims, wherein the first and second hinge positions (S1, S2) are positioned offset relative to a line (L1) in which the upper rail unit (14) substantially extends or relative to a line (L2, L3) in which the respective standard part (6, 8) substantially extends, so that in the transport configuration (CT) between the upper rail unit (14) and the standard parts (6, 8) an intermediate space (18) is formed in which the middle rail unit (16) extends.
 35
4. Rail assembly according to any one of the preceding claims, wherein the rail assembly (2, 102) at at least one of said hinge positions (S1, S2, S3, S4) is provided with a hinge stop to limit a mutual hinging of mutually hingeable parts (6, 8, 14, 16) of the assembly (2, 102), to counteract that hingeable parts (6, 8, 14, 16) of the assembly (2, 102) at the respective hinge position (S1, S2, S3, S4) can be hinged from the transport configuration (CT) to beyond the rail
 40 forming configuration (CL), preferably wherein the rail assembly (2, 102) is dimensioned so as, in the rail forming configuration (CL), by coupling of the assembly (2, 102) to the scaffold (4), to provide to at least one of the hingeable parts (6, 8, 14, 16) a bias in the direction of the hinge stop, so that a substantially play-free configuration is created.
 45
5. Rail assembly according to any one of the preceding claims, wherein the rail assembly (2, 102) is configured to selectively counteract the assembly (2, 102) being brought out of its transport configuration (CT), preferably wherein the arrangement of the rail assembly (2, 102) to selectively counteract the assembly (2, 102) being brought out of its transport configuration (CT) is realized by the coupling means (10, 12).
 50
6. Rail assembly according to any one of the preceding claims, wherein the coupling means (10, 12):
 55 - are configured to couple at least one (8) of the standard parts (6, 8) to the scaffold (4) such that the at least one standard part (8) is detachable from the scaffold (4) without detaching parts of the scaffold (4) itself from each other; and/or
 - are configured to engage, at each of the standard parts (6, 8), the scaffold (4) at at least two mutually different positions (10a, 10b, 12a, 12b); and/or
 - comprise at least one eye (20) to secure the assembly (2, 102) to the scaffold (4); and/or
 - are provided at a distance from the rail units (14, 16).
 60
7. Rail assembly according to any one of the preceding claims, wherein at least a part of the coupling means (10, 12) is provided on at least one of the standard parts (6, 8) to hinge along with the standard part (6, 8) relative to at least one of the rail units (14, 16).
 65
8. Rail assembly (2) according to any one of the preceding claims, wherein the middle rail unit (16) is telescopable to enable varying of a distance (D2) between the third hinge position (S3) and the fourth hinge position (S4).
 70
9. Rail assembly according to claim 8, wherein:
 75 - the upper rail unit (14) defines a fixed distance (D 1) between the first hinge position (S1) and the second hinge position (S2); and/or
 - the middle rail unit (16) comprises a first middle rail part (16a) and a second middle rail part (16b), the middle rail parts (16a, 16b) being connected with each other in a mutually telescopable manner, wherein the first middle rail part

- (16a) comprises the third hinge position (S3) and the second middle rail part (16b) comprises the fourth hinge position (S4); and/or
- the distance (D2) between the third hinge position (S3) and the fourth hinge position (S4) by telescoping of the middle rail unit (16) is smaller in the transport configuration (CT) than in the rail forming configuration (CL); and/or
 - in the rail forming configuration (CL) the first and second hinge positions (S1, S2) are located between a line (L1) in which the upper rail unit (14) substantially extends and a line (L4) in which the middle rail unit (16) substantially extends, preferably wherein the upper rail unit (14) comprises connecting parts (22, 24) which extend from a main part of the upper rail unit (14) radially outwards relative to a line (L1) in which the upper rail unit (14) substantially extends, wherein the first and second hinge positions (S1, S2) are provided on a respective one of said connecting parts (22, 24) at a distance from said line (L1); and/or
 - the middle rail unit (16) is telescopable over a telescoping distance which is at least as great as a sum $d(S1, S3) + d(S2, S4)$ of a distance $d(S1, S3)$ between the first and third hinge positions and a distance $d(S2, S4)$ between the second and fourth hinge positions.
- 10.** Rail assembly (102) according to any one of the preceding claims, wherein the upper rail unit (14) is telescopable to enable varying of a distance (D 1) between the first hinge position (S1) and the second hinge position (S2).
- 11.** Rail assembly according to claim 10, wherein:
- the middle rail unit (16) defines a fixed distance (D2) between the third hinge position (S3) and the fourth hinge position (S4); and/or
 - the upper rail unit (14) comprises a first upper rail part (14a) and a second upper rail part (14b), the upper rail parts (14a, 14b) being connected with each other in a mutually telescopable manner, wherein the first upper rail part (14a) comprises the first hinge position (S1) and the second upper rail part (14b) comprises the second hinge position (S2); and/or
 - the distance (D 1) between the first hinge position (S1) and the second hinge position (S2) by telescoping of the upper rail unit (14) is greater in the transport configuration (CT) than in the rail forming configuration (CL); and/or
 - the first and second hinge positions (S1, S2) are located on a line (L1) in which the upper rail unit (14) substantially extends, preferably wherein the first and second standard parts (6, 8) each comprise a connecting part (26, 28) which extends from a main part of the standard part (6, 8) radially outwards relative to a line (L2, L3) in which the respective standard part (6, 8) substantially extends, wherein the first and second hinge positions (S1, S2) are provided on the respective connecting part (26, 28) at a distance from said line (L2, L3); and/or
 - the upper rail unit (14) is telescopable over a telescoping distance which is at least as great as a sum $d(S1, S3) + d(S2, S4)$ of a distance $d(S1, S3)$ between the first and third hinge positions and a distance $d(S2, S4)$ between the second and fourth hinge positions.
- 12.** Scaffold (4) comprising at least one rail assembly (2, 102) according to any one of the preceding claims, wherein the rail assembly (2, 102) is coupled to the scaffold (4) by means of the coupling means (10, 12).
- 13.** Set of scaffold parts for forming a scaffold (4), comprising a plurality of scaffold parts (4a1, 4a2, 4b, 4c) and at least one rail assembly (2, 102) according to any one of claims 1 - 11, wherein at least one (4a1, 4a2) of the scaffold parts (4a1, 4a2, 4b, 4c) is suitable to couple thereto the rail assembly (2, 102) by means of the coupling means (10, 12).
- 14.** Method for providing a rail on a scaffold (4), comprising:
- providing a rail assembly (2, 102) according to any one of claims 1 - 11;
 - coupling the rail assembly (2, 102) to the scaffold (4) at one (6) of the first standard part (6) and the second standard part (8);
 - moving the other standard part (8) away from the one standard part (6), resulting in one of the upper rail unit (14) and the middle rail unit (16) being telescoped, and the rail units (14, 16) being hinged relative to the standard parts (6, 8); and
 - coupling the rail assembly (2, 102) to the scaffold (4) at the other standard part (8), resulting in the rail assembly (2, 102) in its rail forming configuration (CL) being fixingly coupled to the scaffold (4).
- 15.** Method for augmenting passability of a scaffold (4) which includes a rail assembly (2, 102) according to any one of claims 1 - 11, comprising:
- during use of the scaffold (4), detaching the rail assembly (2, 102) from the scaffold (4) at one (8) of the first standard part (6) and the second standard part (8) while the rail assembly (2, 102) at the other standard part (6) remains coupled to the scaffold (4); and
 - moving the one standard part (8) towards the

other standard part (6), resulting in one of the upper rail unit (14) and the middle rail unit (16) being telescoped, and the rail units (14, 16) being hinged relative to the standard parts (6, 8).

5

Patentansprüche

1. Schienenanordnung (2, 102) für ein Gerüst (4), umfassend:

10

- ein erstes Standardteil (6) und ein zweites Standardteil (8);
- eine obere Schieneneinheit (14), die in einer ersten Gelenkposition (S1) gelenkig mit dem ersten Standardteil (6) und in einer zweiten Gelenkposition (S2) gelenkig mit dem zweiten Standardteil (8) verbunden ist; und
- eine mittlere Schieneneinheit (16), die in einer dritten Gelenkposition (S3) gelenkig mit dem ersten Standardteil (6) und in einer vierten Gelenkposition (S4) gelenkig mit dem zweiten Standardteil (8) verbunden ist,

15

20

wobei die Schienenanordnung (2, 102) mit Kopplungsmitteln (10, 12) versehen ist, die so konfiguriert sind, dass sie die Schienenanordnung (2, 102) fest mit dem Gerüst (4) verbinden,

25

wobei die Schienenanordnung (2, 102) so konfiguriert ist, dass sie durch Anlenkung an den Gelenkpositionen (S1, S2, S3, S4) zwischen einerseits einer Schienenbildungskonfiguration (CL), in der die obere Schieneneinheit (14) und die mittlere Schieneneinheit (16) jeweils eine obere Schiene und eine mittlere Schiene für das Gerüst (4) bilden können, zumindest wenn die Schienenanordnung (2, 102) fest mit dem Gerüst (4) gekoppelt ist, und andererseits einer Transportkonfiguration (CT), die im Vergleich zur Schienenbildungskonfiguration (CL) kompakter ist, eingestellt wird,

30

35

wobei eine von der oberen Schieneneinheit (14) und der mittleren Schieneneinheit (16) teleskopierbar ist, um eine Veränderung eines Abstands (D1 oder D2) zwischen den jeweiligen Gelenkpositionen (S1, S2; oder S3, S4) der einen Schienenanordnung (14 oder 16) zu ermöglichen, zumindest wenn höchstens eines von dem ersten Standardteil (6) und dem zweiten Standardteil (8) mit dem Gerüst (4) gekoppelt ist, wobei die andere von der oberen Schieneneinheit (14) und der mittleren Schieneneinheit (16) nicht teleskopierbar ist,

40

45

dadurch gekennzeichnet, dass in der Transportkonfiguration (CT) das erste

50

55

Standardteil (6) und das zweite Standardteil (8) im Vergleich zur Schienenbildungskonfiguration (CL) um mehr als 120 Grad, vorzugsweise um mehr als 150 Grad, beispielsweise um etwa 180 Grad, um eine imaginäre Achse (X), die sich senkrecht in Bezug auf eine Ebene erstreckt, in der sich die Schienenanordnung (2, 102) im Wesentlichen erstreckt, zueinander gedreht sind,

und/oder dass

sich in der Transportkonfiguration (CT) beide Standardteile (6, 8) im Wesentlichen entlang der Schieneneinheiten (14, 16) erstrecken, ein Abschnitt der mittleren Schieneneinheit (16) sich zwischen der oberen Schieneneinheit (14) und dem ersten Standardteil (6) und ein weiterer Abschnitt der mittleren Schieneneinheit (16) sich zwischen der oberen Schieneneinheit (14) und dem zweiten Standardteil (8) erstreckt.

- ### 2. Schienenanordnung nach Anspruch 1, wobei in der Schienenbildungskonfiguration (CL) das erste Standardteil (6) und das zweite Standardteil (8) jeweils im Wesentlichen in einem Winkel zu mindestens einer der oberen Schieneneinheit (14) und der mittleren Schieneneinheit (16) verlaufen, wobei in der Transportkonfiguration (CT) das erste Standardteil (6), das zweite Standardteil (8), die obere Schieneneinheit (14) und die mittlere Schieneneinheit (16) im Wesentlichen parallel zueinander verlaufen.

- ### 3. Schienenanordnung nach einem der vorstehenden Ansprüche, wobei die erste und zweite Gelenkposition (S1, S2) relativ zu einer Linie (L1), in der sich die obere Schieneneinheit (14) im Wesentlichen erstreckt, oder relativ zu einer Linie (L2, L3), in der sich das jeweilige Standardteil (6, 8) im Wesentlichen erstreckt, versetzt positioniert sind, sodass in der Transportkonfiguration (CT) zwischen der oberen Schieneneinheit (14) und den Standardteilen (6, 8) ein Zwischenraum (18) gebildet ist, in dem sich die mittlere Schieneneinheit (16) erstreckt.

- ### 4. Schienenanordnung nach einem der vorstehenden Ansprüche, wobei die Schienenanordnung (2, 102) an mindestens einer der Gelenkpositionen (S1, S2, S3, S4) mit einem Gelenkansschlag versehen ist, um eine gelenkige Bewegung von gegenseitig gelenkig verbundenen Teilen (6, 8, 14, 16) der Anordnung (2, 102) zu begrenzen, um entgegenzuwirken, dass gelenkig verbundene Teile (6, 8, 14, 16) der Anordnung (2, 102) an der jeweiligen Gelenkposition (S1, S2, S3, S4) von der Transportkonfiguration (CT) über die Schienenbildungskonfiguration (CL) hinaus gelenkt werden können,

- wobei die Schienenanordnung (2, 102) vorzugsweise so dimensioniert ist, dass sie in der Schienenbildungskonfiguration (CL) durch Kopplung der Anordnung (2, 102) mit dem Gerüst (4) für mindestens eines der gelenkigen Teile (6, 8, 14, 16) eine Vorspannung in Richtung des Gelenkanschlags bereitstellt, sodass sich eine im Wesentlichen spielfreie Konfiguration ergibt.
- 5
5. Schienenanordnung nach einem der vorstehenden Ansprüche, wobei die Schienenanordnung (2, 102) so konfiguriert ist, dass sie selektiv dem Herausbringen der Anordnung (2, 102) aus ihrer Transportkonfiguration (CT) entgegenwirkt, wobei die Anordnung der Schienenanordnung (2, 102) zum selektiven Entgegenwirken des Herausbringens der Anordnung (2, 102) aus ihrer Transportkonfiguration (CT) vorzugsweise durch die Kopplungsmittel (10, 12) realisiert wird.
- 10
- 15
- 20
6. Schienenanordnung nach einem der vorstehenden Ansprüche, wobei die Kopplungsmittel (10, 12):
- 25
- so konfiguriert sind, dass sie mindestens eines (8) der Standardteile (6, 8) mit dem Gerüst (4) koppeln, sodass das mindestens eine Standardteil (8) von dem Gerüst (4) lösbar ist, ohne Teile des Gerüsts (4) selbst voneinander zu lösen; und/oder
 - so konfiguriert sind, dass sie an jedem der Standardteile (6, 8) das Gerüst (4) an mindestens zwei voneinander verschiedenen Positionen (10a, 10b, 12a, 12b) in Eingriff nehmen; und/oder
 - mindestens eine Öse (20) zur Befestigung der Anordnung (2, 102) an dem Gerüst (4) umfassen; und/oder
 - in einem Abstand zu den Schieneneinheiten (14, 16) vorgesehen sind.
- 30
- 35
- 40
7. Schienenanordnung nach einem der vorstehenden Ansprüche, wobei mindestens ein Teil der Kopplungsmittel (10, 12) an mindestens einem der Standardteile (6, 8) vorgesehen ist, um zusammen mit dem Standardteil (6, 8) relativ zu mindestens einer der Schieneneinheiten (14, 16) schwenkbar zu sein.
- 45
8. Schienenanordnung (2) nach einem der vorstehenden Ansprüche, wobei die mittlere Schieneneinheit (16) teleskopierbar ist, um einen Abstand (D2) zwischen der dritten Gelenkposition (S3) und der vierten Gelenkposition (S4) zu verändern.
- 50
9. Schienenanordnung nach Anspruch 8, wobei:
- 55
- die obere Schieneneinheit (14) einen festen Abstand (D 1) zwischen der ersten Gelenkposition (S1) und der zweiten Gelenkposition (S2) definiert; und/oder
 - die mittlere Schieneneinheit (16) einen ersten mittleren Schienenteil (16a) und einen zweiten mittleren Schienenteil (16b) umfasst, wobei die mittleren Schienenteile (16a, 16b) in einer gegenseitig teleskopierbaren Weise miteinander verbunden sind, wobei der erste mittlere Schienenteil (16a) die dritte Gelenkposition (S3) umfasst und der zweite mittlere Schienenteil (16b) die vierte Gelenkposition (S4) umfasst; und/oder
 - der Abstand (D2) zwischen der dritten Gelenkposition (S3) und der vierten Gelenkposition (S4) durch Teleskopieren der mittleren Schieneneinheit (16) in der Transportkonfiguration (CT) kleiner ist als in der Schienenbildungskonfiguration (CL); und/oder
 - in der Schienenbildungskonfiguration (CL) die ersten und zweiten Gelenkpositionen (S1, S2) sich zwischen einer Linie (L1), in der sich die obere Schieneneinheit (14) im Wesentlichen erstreckt, und einer Linie (L4), in der sich die mittlere Schieneneinheit (16) im Wesentlichen erstreckt, befinden, wobei vorzugsweise die obere Schieneneinheit (14) Verbindungsteile (22, 24) umfasst, die sich von einem Hauptteil der oberen Schieneneinheit (14) radial nach außen relativ zu einer Linie (L1) erstrecken, in der sich die obere Schieneneinheit (14) im Wesentlichen erstreckt, wobei die erste und die zweite Gelenkposition (S1, S2) an einem jeweiligen der Verbindungsteile (22, 24) in einem Abstand von der Linie (L1) vorgesehen sind; und/oder
 - die mittlere Schieneneinheit (16) über eine Teleskopstrecke teleskopierbar ist, die mindestens so groß ist wie die Summe $d(S1, S3) + d(S2, S4)$ eines Abstands $d(S1, S3)$ zwischen der ersten und dritten Gelenkposition und eines Abstands $d(S2, S4)$ zwischen der zweiten und vierten Gelenkposition.
10. Schienenanordnung (102) nach einem der vorstehenden Ansprüche, wobei die obere Schieneneinheit (14) teleskopierbar ist, um einen Abstand (D 1) zwischen der ersten Gelenkposition (S1) und der zweiten Gelenkposition (S2) zu verändern.
11. Schienenanordnung nach Anspruch 10, wobei:
- die mittlere Schieneneinheit (16) einen festen Abstand (D2) zwischen der dritten Gelenkposition (S3) und der vierten Gelenkposition (S4) definiert; und/oder
 - die obere Schieneneinheit (14) einen ersten oberen Schienenteil (14a) und einen zweiten oberen Schienenteil (14b) umfasst, wobei die oberen Schienenteile (14a, 14b) in einer gegenseitig teleskopierbaren Weise miteinander ver-

- bunden sind, wobei der erste obere Schienenteil (14a) die erste Gelenkposition (S1) umfasst und der zweite obere Schienenteil (14b) die zweite Gelenkposition (S2) umfasst; und/oder
- der Abstand (D 1) zwischen der ersten Gelenkposition (S1) und der zweiten Gelenkposition (S2) durch Teleskopieren der oberen Schieneneinheit (14) in der Transportkonfiguration (CT) größer ist als in der Schienenbildungskonfiguration (CL); und/oder
 - sich die erste und die zweite Gelenkposition (S1, S2) auf einer Linie (L1) befinden, in der sich die obere Schieneneinheit (14) im Wesentlichen erstreckt, wobei vorzugsweise das erste und das zweite Standardteil (6, 8) jeweils ein Verbindungsteil (26, 28) umfassen, das sich von einem Hauptteil des Standardteils (6, 8) radial nach außen relativ zu einer Linie (L2, L3) erstreckt, in der sich das jeweilige Standardteil (6, 8) im Wesentlichen erstreckt, wobei die erste und die zweite Gelenkposition (S1, S2) an dem jeweiligen Verbindungsteil (26, 28) in einem Abstand von der Linie (L2, L3) vorgesehen sind; und/oder
 - die obere Schieneneinheit (14) über eine Teleskopstrecke teleskopierbar ist, die mindestens so groß ist wie die Summe $d(S1, S3) + d(S2, S4)$ eines Abstands $d(S1, S3)$ zwischen der ersten und dritten Gelenkposition und eines Abstands $d(S2, S4)$ zwischen der zweiten und vierten Gelenkposition.
- 12.** Gerüst (4), das mindestens eine Schienenanordnung (2, 102) nach einem der vorstehenden Ansprüche umfasst, wobei die Schienenanordnung (2, 102) mittels der Kopplungsmittel (10, 12) mit dem Gerüst (4) gekoppelt ist.
- 13.** Gerüstteilensatz zur Bildung eines Gerüsts (4), der eine Vielzahl von Gerüstteilen (4a1, 4a2, 4b, 4c) und mindestens eine Schienenanordnung (2, 102) nach einem der Ansprüche 1 bis 11 umfasst, wobei mindestens eines (4a1, 4a2) der Gerüstteile (4a1, 4a2, 4b, 4c) geeignet ist, mit der Schienenanordnung (2, 102) mittels der Kopplungsmittel (10, 12) gekoppelt zu werden.
- 14.** Verfahren zum Vorsehen einer Schiene an einem Gerüst (4), umfassend:
- Vorsehen einer Schienenanordnung (2, 102) nach einem der Ansprüche 1 bis 11;
 - Verbinden der Schienenanordnung (2, 102) mit dem Gerüst (4) an einem (6) des ersten Standardteils (6) und des zweiten Standardteils (8);
 - Bewegen des anderen Standardteils (8) weg von dem einen Standardteil (6), was dazu führt, dass entweder die obere Schieneneinheit (14)

oder die mittlere Schieneneinheit (16) teleskopiert wird und die Schieneneinheiten (14, 16) relativ zu den Standardteilen (6, 8) angelenkt werden; und

- Koppeln der Schienenanordnung (2, 102) mit dem Gerüst (4) an dem anderen Standardteil (8), was dazu führt, dass die Schienenanordnung (2, 102) in ihrer Schienenbildungskonfiguration (CL) fest mit dem Gerüst (4) gekoppelt ist.

- 15.** Verfahren zur Erweiterung der Möglichkeiten eines Gerüsts (4), das eine Schienenanordnung (2, 102) nach einem der Ansprüche 1 bis 11 beinhaltet, umfassend:

- während der Verwendung des Gerüsts (4), Lösen der Schienenanordnung (2, 102) von dem Gerüst (4) an einem (8) des ersten Standardteils (6) und des zweiten Standardteils (8), während die Schienenanordnung (2, 102) an dem anderen Standardteil (6) mit dem Gerüst (4) gekoppelt bleibt; und
- Bewegen des einen Standardteils (8) in Richtung des anderen Standardteils (6), was dazu führt, dass entweder die obere Schieneneinheit (14) oder die mittlere Schieneneinheit (16) teleskopiert wird und die Schieneneinheiten (14, 16) relativ zu den Standardteilen (6, 8) angelenkt werden.

Revendications

- 1.** Ensemble de rail (2, 102) pour un échafaudage (4), comprenant :
- (8) ; une première partie standard (6) et une seconde partie standard
 - une unité de rail supérieure (14) qui en une première position d'articulation (S1) est reliée de manière articulée à la première partie standard (6) et au niveau d'une seconde position d'articulation (S2) est reliée de manière articulée à la seconde partie standard (8) ; et
 - une unité de rail intermédiaire (16) qui au niveau d'une troisième position d'articulation (S3) est reliée de manière articulée à la première partie standard (6) et au niveau d'une quatrième position d'articulation (S4) est reliée de manière articulée à la seconde partie standard (8),
 - dans lequel l'ensemble de rail (2, 102) est pourvu de moyens d'accouplement (10, 12) qui sont configurés pour coupler l'ensemble de rail (2, 102) de manière fixe à l'échafaudage (4),
 - dans lequel l'ensemble de rail (2, 102) est configuré pour être ajusté par articulation au niveau desdites positions d'articulation (S1, S2, S3, S4) entre d'une part une configuration de formation

de rail (CL), dans laquelle l'unité de rail supérieure (14) et l'unité de rail intermédiaire (16) peuvent former respectivement un rail supérieur et un rail intermédiaire pour l'échafaudage (4), au moins quand l'ensemble de rail (2, 102) est couplé de manière fixe à l'échafaudage (4), et d'autre part une configuration de transport (CT), qui est plus compacte en comparaison de la configuration de formation de rail (CL),

dans lequel une de l'unité de rail supérieure (14) et de l'unité de rail intermédiaire (16) est télescopique pour permettre de faire varier une distance (D1 ou D2) entre les positions d'articulation (S1, S2; ou S3, S4) respectives de l'un ensemble de rail (14 ou 16), au moins quand au plus une de la première partie standard (6) et la seconde partie standard (8) est couplée à l'échafaudage (4), dans lequel l'autre de l'unité de rail supérieure (14) et l'unité de rail intermédiaire (16) n'est pas télescopique,

caractérisé en ce que

dans la configuration de transport (CT), en comparaison de la configuration de formation de rail (CL), la première partie standard (6) et la seconde partie standard (8) sont mutuellement tournées l'une vers l'autre sur plus de 120 degrés, de préférence plus de 150 degrés, par exemple environ 180 degrés, autour d'un axe imaginaire (X) qui s'étend perpendiculairement par rapport à un plan dans lequel l'ensemble de rail (2, 102) s'étend sensiblement,

et/ou en ce que

dans la configuration de transport (CT) les deux parties standard (6, 8) s'étendent sensiblement le long des unités de rail (14, 16), une partie de l'unité de rail intermédiaire (16) s'étend entre l'unité de rail supérieure (14) et la première partie standard (6), et une autre partie de l'unité de rail intermédiaire (16) s'étend entre l'unité de rail supérieure (14) et la seconde partie standard (8).

2. Ensemble de rail selon la revendication 1, dans lequel dans la configuration de formation de rail (CL) la première partie standard (6) et la seconde partie standard (8) s'étendent chacune sensiblement à un angle vers moins une de l'unité de rail supérieure (14) et de l'unité de rail intermédiaire (16), dans lequel dans la configuration de transport (CT) la première partie standard (6), la seconde partie standard (8), l'unité de rail supérieure (14) et l'unité de rail intermédiaire (16) s'étendent sensiblement parallèles les unes aux autres.
3. Ensemble de rail selon l'une quelconque des revendications précédentes, dans lequel les première et seconde positions d'articulation (S1, S2) sont positionnées décalées relativement à une ligne (L1) dans

laquelle l'unité de rail supérieure (14) s'étend sensiblement ou relativement à une ligne (L2, L3) dans laquelle la partie standard (6, 8) respective s'étend sensiblement, de telle manière que dans la configuration de transport (CT) entre l'unité de rail supérieure (14) et les parties standard (6, 8) un espace intermédiaire (18) est formé dans lequel l'unité de rail intermédiaire (16) s'étend.

4. Ensemble de rail selon l'une quelconque des revendications précédentes, dans lequel l'ensemble de rail (2, 102) dans au moins une desdites positions d'articulation (S1, S2, S3, S4) est pourvu d'un arrêt d'articulation pour limiter une articulation mutuelle de parties mutuellement articulables (6, 8, 14, 16) de l'ensemble (2, 102), pour empêcher que des parties articulables (6, 8, 14, 16) de l'ensemble (2, 102) en des positions d'articulation (S1, S2, S3, S4) respectives puissent être articulées de la configuration de transport (CT) vers au-delà de la configuration de formation de rail (CL), de préférence dans lequel l'ensemble de rail (2, 102) est dimensionné de façon à, dans la configuration de formation de rail (CL), en couplant l'ensemble de rail (2, 102) à l'échafaudage (4), fournir à au moins une des parties articulables (6, 8, 14, 16) une sollicitation dans la direction de l'arrêt d'articulation, de telle manière qu'une configuration sensiblement sans jeu est créée.
5. Ensemble de rail selon l'une quelconque des revendications précédentes, dans lequel l'ensemble de rail (2, 102) est configuré pour empêcher sélectivement l'ensemble de rail (2, 102) d'être amené hors de sa configuration de transport (CT), de préférence dans lequel l'agencement de l'ensemble de rail (2, 102) pour empêcher sélectivement l'ensemble de rail (2, 102) d'être amené hors de sa configuration de transport (CT) est réalisé par les moyens d'accouplement (10, 12).
6. Ensemble de rail selon l'une quelconque des revendications précédentes, dans lequel les moyens d'accouplement (10, 12) ;

sont configurés pour coupler au moins une (8) des parties standard (6, 8) à l'échafaudage (4) de telle manière que l'au moins une partie standard (8) peut être détachée de l'échafaudage (4) sans détacher des parties de l'échafaudage (4) lui-même les unes des autres ; et/ou sont configurés pour venir en prise, au niveau de chacune des parties standard (6, 8), avec l'échafaudage (4) en au moins deux positions mutuellement différentes (10a, 10b, 12a, 12b) ; et/ou comprennent au moins un oeil (20) pour fixer l'ensemble (2, 102) sur l'échafaudage (4) ; et/ou

sont placés à distance des unités de rail (14, 16).

7. Ensemble de rail selon l'une quelconque des revendications précédentes, dans lequel au moins une partie des moyens d'accouplement (10, 12) est placée sur au moins une des parties standard (6, 8) pour articulation conjointement avec la partie standard (6, 8) relativement à au moins une des unités de rail (14, 16).

8. Ensemble de rail (2) selon l'une quelconque des revendications précédentes, dans lequel l'unité de rail intermédiaire (16) est télescopique pour permettre de faire varier une distance (D2) entre la troisième position d'articulation (S3) et la quatrième position d'articulation (S4).

9. Ensemble de rail selon la revendication 8, dans lequel :

l'unité de rail supérieure (14) définit une distance fixe (D1) entre la première position d'articulation (S1) et la seconde position d'articulation (S2) ; et/ou

l'unité de rail intermédiaire (16) comprend une première partie de rail intermédiaire (16a) et une seconde partie de rail intermédiaire (16b), les parties de rail intermédiaire (16a, 16b) étant reliées ensemble d'une manière mutuellement télescopique, dans lequel la première partie de rail intermédiaire (16a) comprend la troisième position d'articulation (S3) et la seconde partie de rail intermédiaire (16b) comprend la quatrième position d'articulation (S4) ; et/ou

la distance (D2) entre la troisième position d'articulation (S3) et la quatrième position d'articulation (S4) par télescopie de l'unité de rail intermédiaire (16) est plus petite dans la configuration de transport (CT) que dans la configuration de formation de rail (CL) ; et/ou

dans la configuration de formation de rail (CL) les première et seconde positions d'articulation (S1, S2) sont situées entre une ligne (L1) dans laquelle l'unité de rail supérieure (14) s'étend sensiblement et une ligne (L4) dans laquelle l'unité de rail intermédiaire (16) s'étend sensiblement, de préférence dans lequel l'unité de rail supérieure (14) comprend des parties de liaison (22, 24) qui s'étendent depuis une partie principale de l'unité de rail supérieure (14) radialement vers l'extérieur relativement à une ligne (L1) dans laquelle l'unité de rail supérieure (14) s'étend sensiblement, dans lequel les première et seconde positions d'articulation (S1, S2) sont placées sur l'une respective desdites parties de liaison (22, 24) à distance de ladite ligne (L1) ; et/ou

l'unité de rail intermédiaire (16) est télescopique

sur une distance qui est au moins aussi grande qu'une somme $d(S1, S3) + d(S2, S4)$ d'une distance $d(S1, S3)$ entre les première et troisième positions d'articulation et une distance $d(S2, S4)$ entre les seconde et quatrième positions d'articulation.

10. Ensemble de rail (102) selon l'une quelconque des revendications précédentes, dans lequel l'unité de rail supérieure (14) est télescopique pour permettre de faire varier une distance (D1) entre la première position d'articulation (S1) et la seconde position d'articulation (S2).

11. Ensemble de rail selon la revendication 10, dans lequel :

l'unité de rail intermédiaire (16) définit une distance fixe (D2) entre la troisième position d'articulation (S3) et la quatrième position d'articulation (S4) ; et/ou

l'unité de rail supérieure (14) comprend une première partie de rail supérieure (14a) et une seconde partie de rail supérieure (14b), les parties de rail supérieures (14a, 14b) étant reliées ensemble d'une manière mutuellement télescopique, dans lequel la première partie de rail supérieure (14a) comprend la première position d'articulation (S1) et la seconde partie de rail supérieure (14b) comprend la seconde position d'articulation (S2) ; et/ou

la distance (D1) entre la première position d'articulation (S1) et la seconde position d'articulation (S2) par télescopie de l'unité de rail supérieure (14) est plus grande dans la configuration de transport (CT) que dans la configuration de formation de rail (CL) ; et/ou

les première et seconde positions d'articulation (S1, S2) sont situées sur une ligne (L1) dans laquelle l'unité de rail supérieure (14) s'étend sensiblement, de préférence dans lequel les première et seconde parties standard (6, 8) comprennent chacune une partie de liaison (26, 28) qui s'étend depuis une partie principale de la partie standard (6, 8) radialement vers l'extérieur relativement à une ligne (L2, L3) dans laquelle la partie standard (6, 8) respective s'étend sensiblement, dans lequel les première et seconde positions d'articulation (S1, S2) sont placées sur la partie de liaison (26, 28) respective à distance de ladite ligne (L2, L3) ; et/ou

l'unité de rail supérieure (14) est télescopique sur une distance qui est au moins aussi grande qu'une somme $d(S1, S3) + d(S2, S4)$ d'une distance $d(S1, S3)$ entre les première et troisième positions d'articulation et une distance $d(S2, S4)$ entre les seconde et quatrième positions d'articulation.

12. Echafaudage (4) comprenant au moins un ensemble de rail (2, 102) selon l'une quelconque des revendications précédentes, dans lequel l'ensemble de rail (2, 102) est couplé à l'échafaudage (4) au moyen des moyens d'accouplement (10, 12). 5
13. Ensemble de parties d'échafaudage pour former un échafaudage (4), comprenant une pluralité de parties d'échafaudage (4a1, 4a2, 4b, 4c) et au moins un ensemble de rail (2, 102) selon l'une quelconque des revendications 1-11, dans lequel au moins une (4a1, 4a2) des parties d'échafaudage (4a1, 4a2, 4b, 4c) convient pour coupler à celle-ci l'ensemble de rail (2, 102) au moyen des moyens d'accouplement (10, 12). 10
15
14. Procédé pour fournir un rail sur un échafaudage (4), comprenant :
- de fournir un ensemble de rail (2, 102) selon l'une quelconque des revendications 1-11 ; 20
de coupler l'ensemble de rail (2, 102) à l'échafaudage (4) au niveau d'une de la première partie standard (6) et la seconde partie standard (8) ; 25
d'éloigner l'autre partie standard (8) de la première partie standard (6), provoquant la télescopie de l'une de l'unité de rail supérieure (14) et l'unité de rail intermédiaire (16), et les unités de rail (14, 16) étant articulées relativement aux parties standard (6, 8) ; et 30
de coupler l'ensemble de rail (2, 102) à l'échafaudage (4) au niveau de l'autre partie standard (8), faisant que l'ensemble de rail (2, 102) dans sa configuration de formation de rail (CL) est couplé fixement à l'échafaudage (4). 35
15. Procédé pour augmenter la praticabilité d'un échafaudage (4) qui inclut un ensemble de rail (2, 102) selon l'une quelconque des revendications 1-11, comprenant : 40
- pendant l'utilisation de l'échafaudage (4), de détacher l'ensemble de rail (2, 102) de l'échafaudage (4) au niveau d'une (8) de la première partie standard (6) et la seconde partie standard (8) alors que l'ensemble de rail (2, 102) au niveau de l'autre partie standard (6) demeure couplé à l'échafaudage (4) ; et 45
de déplacer l'une partie standard (8) vers l'autre partie standard (6), provoquant la télescopie de l'unité de rail supérieure (14) et l'unité de rail intermédiaire (16), et les unités de rail (14, 16) étant articulées relativement aux parties standard (6, 8). 50
55

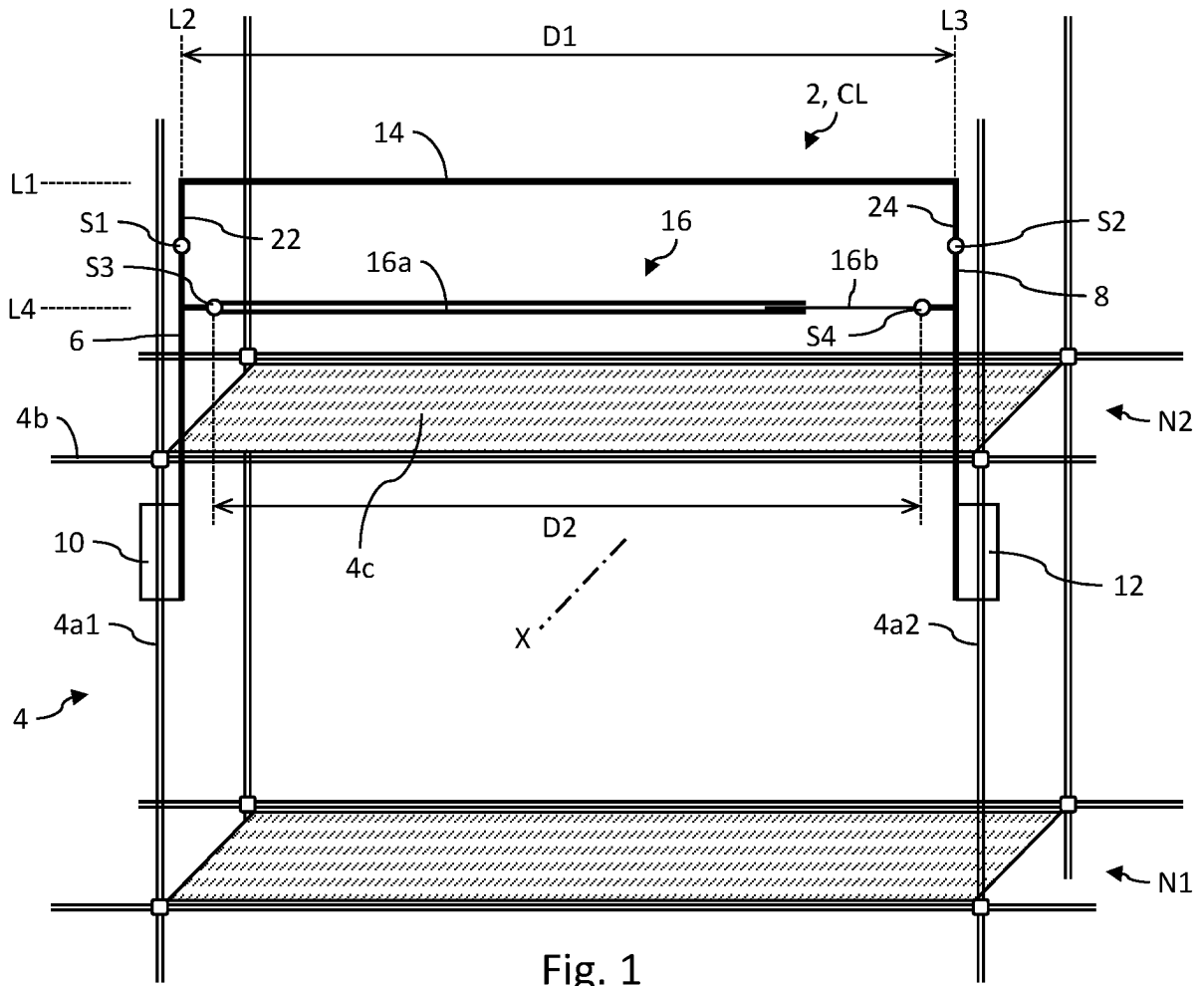

Fig. 1

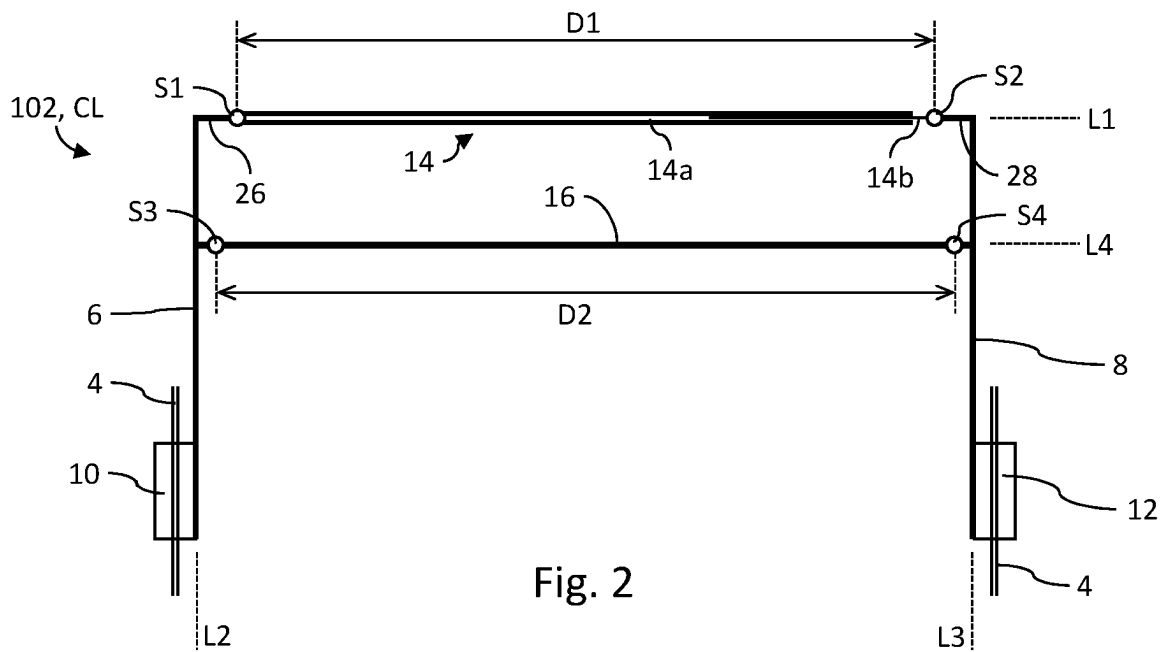

Fig. 2

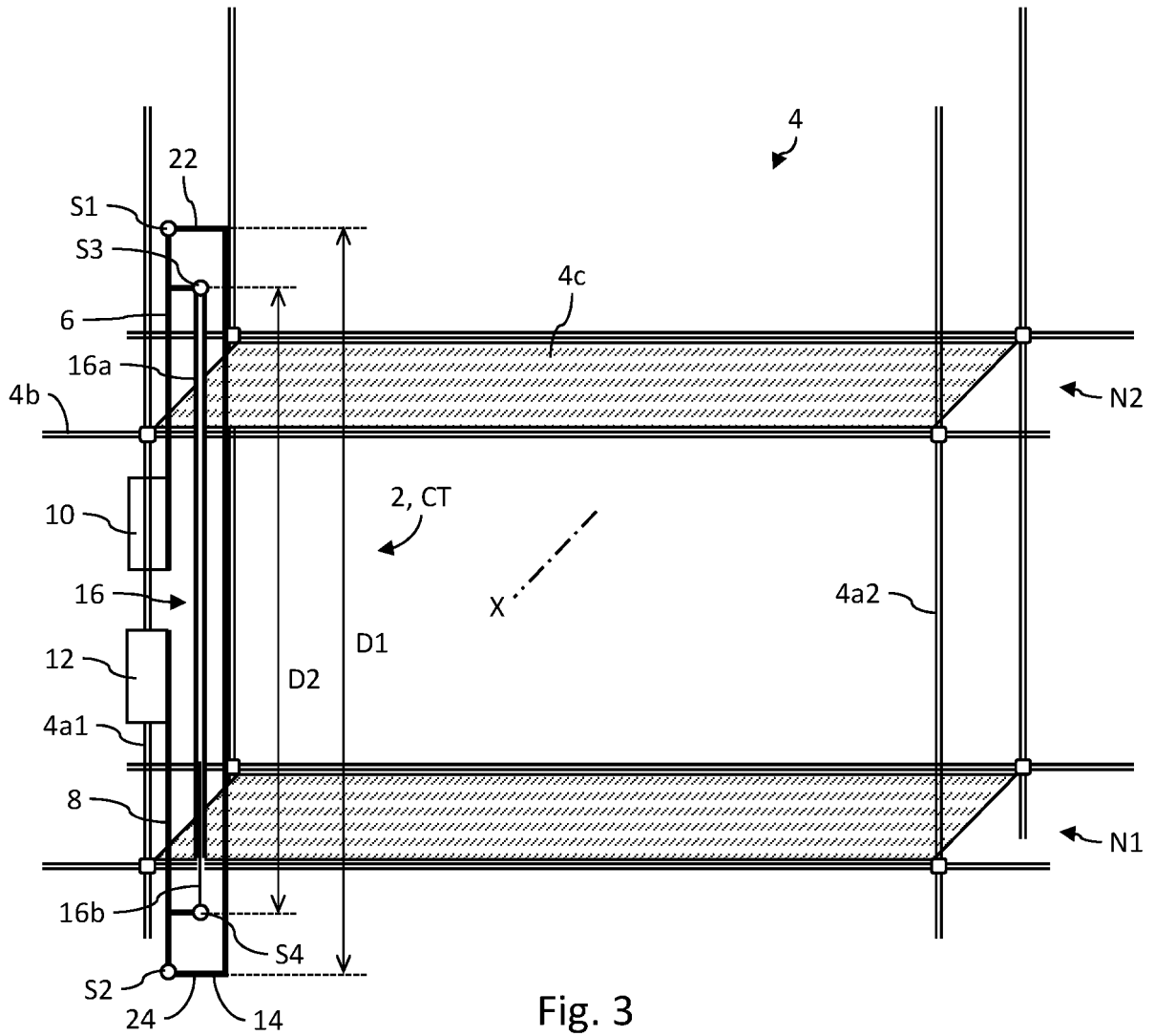

Fig. 3

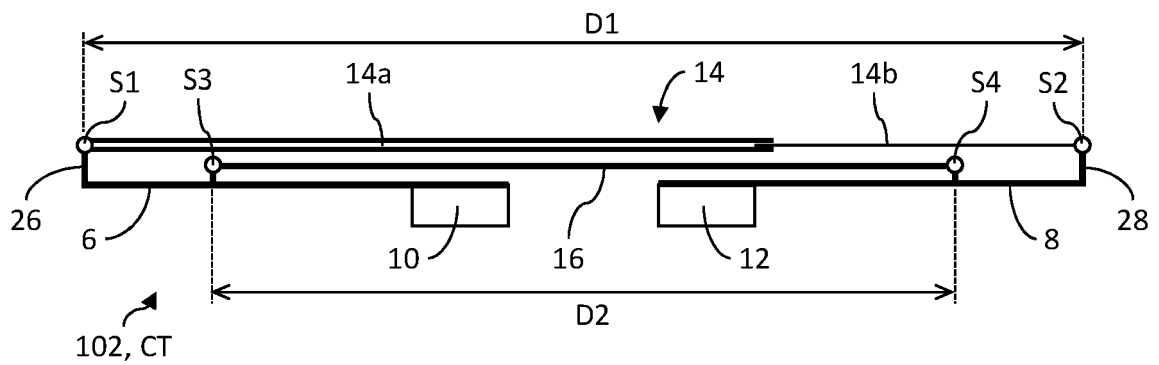

Fig. 4

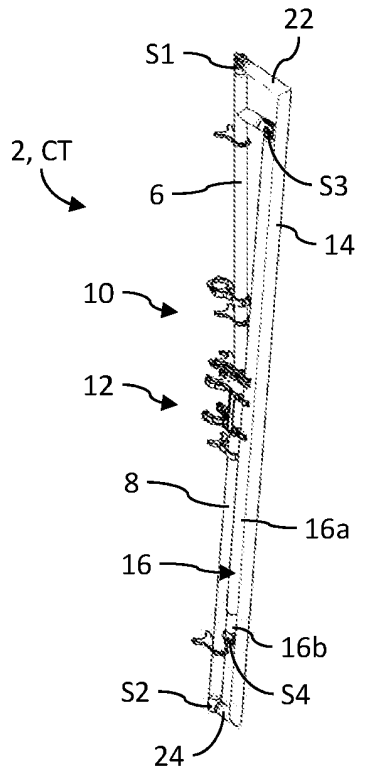

Fig. 5A

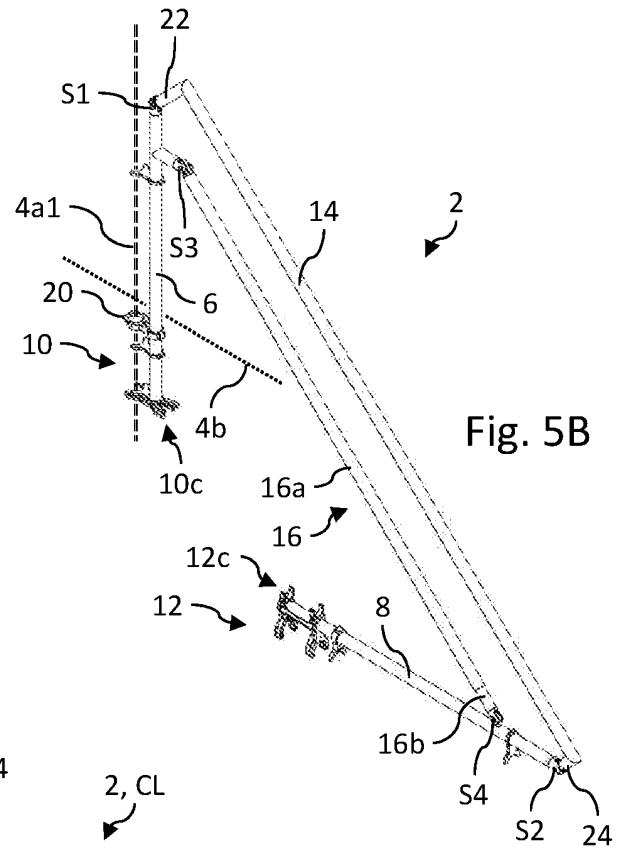

Fig. 5B

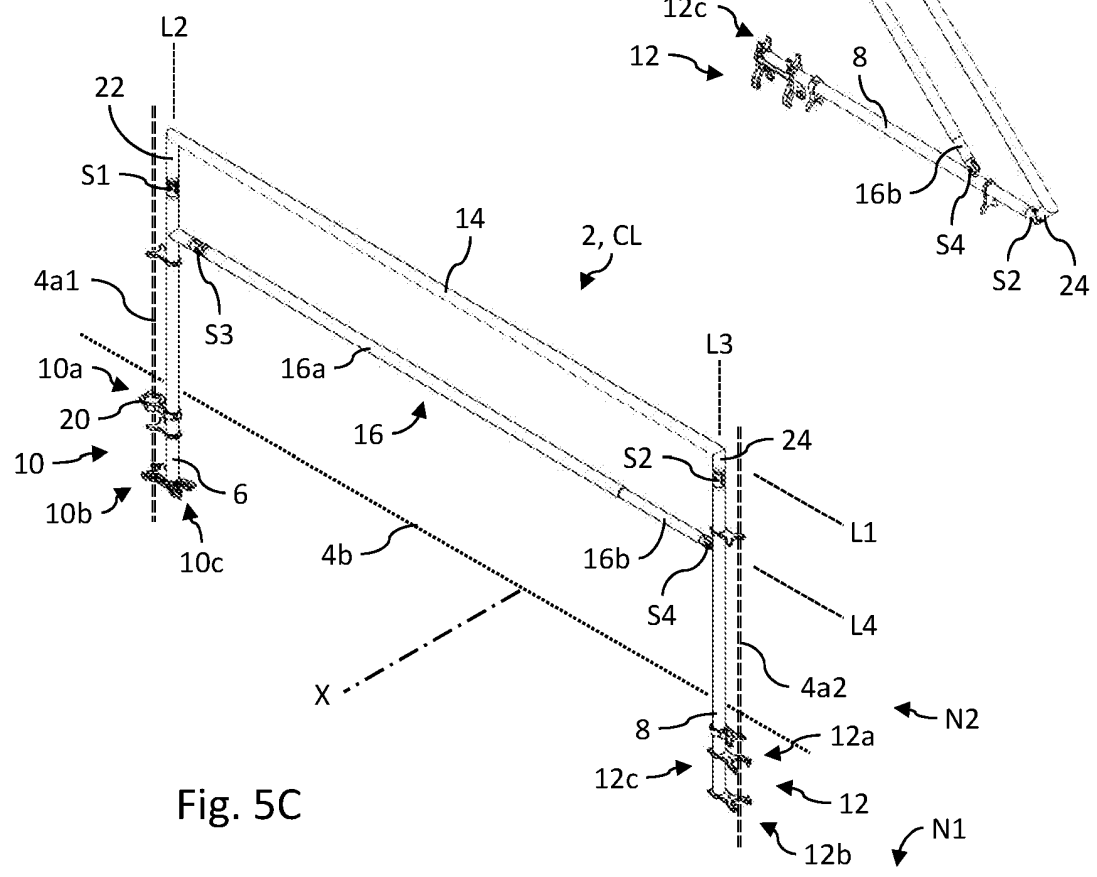
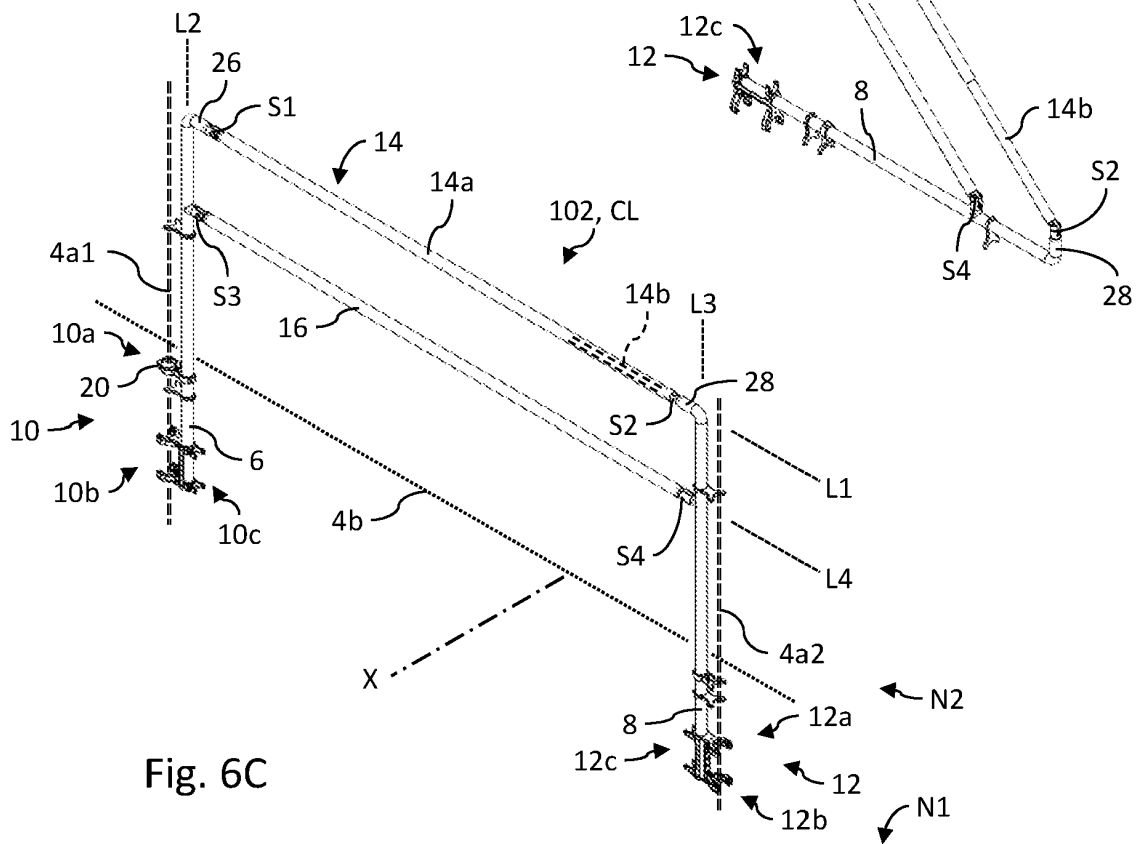
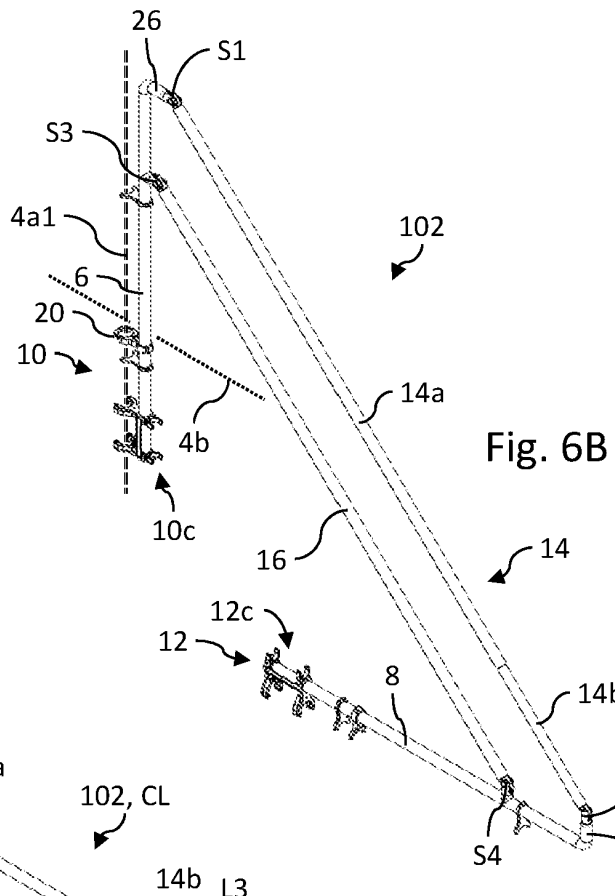
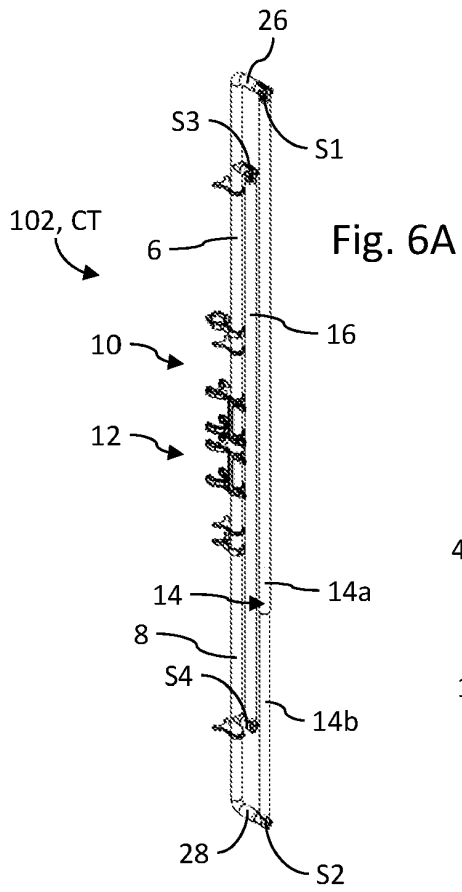

Fig. 5C



REFERENCES CITED IN THE DESCRIPTION

This list of references cited by the applicant is for the reader's convenience only. It does not form part of the European patent document. Even though great care has been taken in compiling the references, errors or omissions cannot be excluded and the EPO disclaims all liability in this regard.

Patent documents cited in the description

- WO 02077392 A1 [0004]
- JP 2005188275 A [0004]
- WO 2020192811 A1 [0004]
- JP 2007100495 A [0004]
- JP 2010242419 A [0004]