

(19)



(11)

EP 4 256 204 B1

(12)

EUROPEAN PATENT SPECIFICATION

(45) Date of publication and mention of the grant of the patent:
25.12.2024 Bulletin 2024/52

(51) International Patent Classification (IPC):
F04B 43/08^(2006.01) F04B 43/12^(2006.01)

(21) Application number: **21834839.9**

(52) Cooperative Patent Classification (CPC):
F04B 43/1246; F04B 43/082; F04B 43/1238

(22) Date of filing: **30.11.2021**

(86) International application number:
PCT/GB2021/053111

(87) International publication number:
WO 2022/118003 (09.06.2022 Gazette 2022/23)

(54) **PUMP**

PUMPE

POMPE

(84) Designated Contracting States:
AL AT BE BG CH CY CZ DE DK EE ES FI FR GB GR HR HU IE IS IT LI LT LU LV MC MK MT NL NO PL PT RO RS SE SI SK SM TR

(72) Inventors:
• **MORSE, Simon**
Hemel Hempstead Hertfordshire HP2 4TZ (GB)
• **BAILE, Darron**
Hemel Hempstead Hertfordshire HP2 4TZ (GB)

(30) Priority: **01.12.2020 GB 202018960**

(74) Representative: **Lewis Silkin LLP**
Arbor
255 Blackfriars Road
London SE1 9AX (GB)

(43) Date of publication of application:
11.10.2023 Bulletin 2023/41

(73) Proprietor: **Britvic Soft Drinks Limited**
Hemel Hempstead, Hampshire HP2 4TZ (GB)

(56) References cited:
DE-C- 146 483 GB-A- 2 128 262
US-A- 2 015 574 US-A- 3 899 010

EP 4 256 204 B1

Note: Within nine months of the publication of the mention of the grant of the European patent in the European Patent Bulletin, any person may give notice to the European Patent Office of opposition to that patent, in accordance with the Implementing Regulations. Notice of opposition shall not be deemed to have been filed until the opposition fee has been paid. (Art. 99(1) European Patent Convention).

Description

[0001] The present invention relates to a pump, and in particular to a peristaltic pump, and a fluid delivery system comprising the pump.

[0002] Peristaltic pumps are a type of positive displacement pump used for pumping a variety of fluids. A typical peristaltic pump comprises a flexible tube for conveying the fluid through compression of the tube in a peristaltic manner. Fluid is pushed or pulled through the tube by moving the region of compression along the length of the tube. Compression of the tube is typically achieved by mechanically driven rollers which pinch off a section of the tube. A typical peristaltic pump thus comprises a plurality of rollers between which fluid is trapped: as the rollers rotate, the trapped fluid is transported through the tube towards the pump outlet. Peristaltic pumps are often used where the flow of fluid needs to be carefully metered, i.e. where small amounts of fluid need to be accurately delivered. Peristaltic pumps are thus widely used in medical applications, for example for delivering IV fluids to patients, and food and beverage applications.

[0003] However, typical peristaltic pumps can suffer from problems with the accuracy of fluid dosing. For example, some peristaltic pumps can suffer from flat spots in fluid delivery, and pulsating fluid delivery.

[0004] The present invention seeks to provide a peristaltic pump with improved accuracy of fluid delivery compared to prior art pumps.

GB 2128262 discloses a peristaltic pump comprising a fluid inlet and outlet; a carrier member having an outer surface; flexible tubing for conveying a fluid which extends at least partially around the outer surface of the carrier member; and a drivable compression roller; wherein the carrier member and compression roller can be positioned adjacent one another to compress the flexible tubing there between.

[0005] Thus, according to the present invention there is provided a peristaltic pump comprising:

- a fluid inlet and outlet;
- a carrier member having an outer surface;
- flexible tubing for conveying a fluid which extends at least partially around the outer surface of the carrier member; and
- a drivable compression roller;

wherein the carrier member and compression roller are positioned adjacent one another to compress the flexible tubing therebetween, and the compression roller rotated about an axis of rotation to thereby cause the carrier member and flexible tubing to rotate about an axis of rotation, by which fluid within the flexible tubing can be conveyed along the flexible tubing between the inlet and outlet.

[0006] The peristaltic pump of the present invention thus conveys fluid using the same principles as a conventional peristaltic pump, i.e. fluid is conveyed along

flexible tubing by compressing the flexible tubing and moving the point of compression along the flexible tubing. However, in the peristaltic pump of the present invention, unlike a conventional peristaltic pump, rollers do not rotate about an internal central axis relative to flexible tubing which is fixed in position, for example within and relative to a housing or manifold. Instead, in the pump of the present invention the flexible tubing moves relative to the compression roller, through rotation of the carrier member about its rotational axis, on which the flexible tubing is positioned, driven by rotation of the compression roller. Thus, in use when the compression roller and carrier member are positioned to convey fluid through the flexible tubing, with the flexible tubing compressed therebetween, the axis of rotation of the carrier member and the axis of rotation of the compression roller/flexible tubing are in fixed positions relative to each other. In this way, greater accuracy of fluid delivery can be achieved compared to conventional peristaltic pumps. For example, the compression roller may have a circumference substantially smaller than that of the carrier member, meaning that rotation of the compression roller through a full 360° rotation corresponds to rotation of the carrier member, and hence the flexible tubing, through only a fraction (arc) of the circumference of the carrier member. For example, the ratio of the circumference of the compression roller to the carrier member may be from 1:10 to 1:15 or 1:20, meaning that, for these ratios, a full 360° rotation of the compression roller would rotate the carrier member through 36°, 27° and 18° respectively. This arrangement allows for very accurate control of the amount of fluid being conveyed through the flexible tubing. However, the relative sizes of the compression roller and carrier member are not limited, and may be selected as desired according to the requirements of the pump.

[0007] The peristaltic pump of the present invention thus comprises a carrier member having an outer surface on which the flexible tubing is positioned and extends at least partially around. The carrier member preferably takes the form of a rotatable wheel with the flexible tubing positioned around its outer circumference. For example, the carrier member may comprise circumferential flanges between which the flexible tubing may be positioned. The flanges may have a depth which is equal to or less than the thickness of the flexible tubing material. The flexible tubing preferably extends around the carrier member as a single turn coil.

[0008] The flexible tubing used in the peristaltic pump of the present invention may be formed of any material which is suitable for the intended purpose of the pump, and in particular the fluid to be conveyed. For example, suitable materials may include polyvinyl chloride, silicone, polyurethane and natural rubber. For example, for delivery of a beverage or a beverage ingredient, a preferred material is silicone. The thickness of the tubing material may also be selected according to requirements, for example to be equal to or greater than the depth of circumferential flanges of the carrier member.

[0009] In use, fluid enters the pump through the inlet from a fluid source, such as a fluid reservoir or container. Thus, the pump may comprise an inlet pipe or tube for insertion into a fluid reservoir through which fluid may be drawn into the pump through the flexible tubing.

[0010] As described herein, in use the flexible tubing moves relative to the rotational axis of the compression roller as the carrier member rotates, driven by the compression roller. Thus, in use the flexible tubing rotates with the carrier member about its rotational axis. To allow the flexible tubing to rotate in this way without twisting, the flexible tubing may be connected to the pump outlet via a fluid-tight movable joint, such as a rotary joint, to allow relative movement between the flexible tubing and the pump outlet. Thus, in an embodiment of the pump of the present invention, the fluid flow path may comprise an inlet comprising a pipe or tube which in use is in fluid communication with a fluid source and also with the flexible tubing, and the flexible tubing extends from the inlet around the circumference of the carrier member to the pump outlet via a fluid-tight movable joint, such as a rotary joint. The flexible tubing may be connected to the pump inlet by a movable joint, such as a rotary joint.

[0011] The pump of the present invention further comprises a drivable compression roller positionable relative to the carrier member so as to compress the flexible tubing between the compression roller and carrier member. The compression roller is rotatable about an axis of rotation, and is preferably driven by a rotary drive, such as an electric motor. The compression roller is preferably rotatable in opposite directions, i.e. both forwards and backwards. In this way, the compression roller can be driven in a first direction to dispense fluid from the reservoir to a desired location through the flexible tubing, and can be driven in a second, opposite direction to allow fluid in the flexible tubing to be returned to the fluid reservoir. Driving the compression roller in the second direction also allows a cleaning fluid, such as water, to be drawn into the flexible tubing to clean the flexible tubing and thus help to prevent cross-contamination if the pump is being used to deliver a plurality of different fluids.

[0012] The compression roller preferably takes the form of a wheel or cylinder, and may have a circumference which is substantially smaller than the circumference of the carrier member. In this way, a full 360° rotation of the compression roller corresponds to rotation of the carrier member, and hence the flexible tubing, through only a small fraction (arc) of the circumference of the carrier member. The specific gearing, i.e. relative sizes of the compression roller and carrier member, to be used in a particular pump will depend upon the intended use of the pump. Thus, a smaller diameter compression roller relative to the carrier member will provide greater accuracy in fluid delivery, but will require a greater degree of or number of rotations to deliver the same amount of fluid as a compression roller having a greater diameter relative to the carrier member. The thickness/depth of the compression roller may be selected according to the corre-

sponding dimensions and configuration of the carrier member and flexible tubing. For example, if the carrier member comprises circumferential flanges to retain the flexible tubing in position then the compression roller may have a thickness/depth selected so the compression roller sits between the flanges to compress the flexible tubing. Alternatively, the compression roller may take the form of an elongate cylinder which can press against the flanges to compress the flexible tubing within the flanges, for example where the flexible tubing is formed from a material which has a thickness equal to or greater than the depth of the flanges. The pump of the present invention may comprise more than one compression roller, radially circumferentially spaced around the carrier member, according to the requirements of the pump. All, some, or only one of the compression rollers may be drivable, for example by an electric motor.

[0013] During operation of the pump it is possible that continuous flow of fluid through the flexible tubing may be interrupted due to gaps or "dead spots" in which fluid is absent from the flexible tubing. These dead spots may be more prevalent at points of greater curvature of the flexible tubing, for example where the flexible tubing first comes into contact with the carrier member downstream of the inlet, and where the flexible tubing leaves the carrier member going towards the outlet. To help ensure that the desired amount of fluid is delivered by the pump, the pump may be configured to recognize any dead spots, for example using a microswitch, and adjust the run of the motor accordingly to take the dead spot(s) into account.

[0014] The pump of the present invention may be used to accurately deliver small amounts of fluid in different applications, such as medical applications, or food and drink applications. For example, the pump may be used to dispense a beverage or beverage ingredient, such as a flavouring, vitamin, fibre, or caffeine. The pump may be configured to dispense the fluid, for example beverage or beverage additive, in a predetermined amount, for example by driving the compression roller for a predetermined length of time, preferably adjusted to take into account any interruptions in fluid flow due to dead spots, as discussed above.

[0015] The pump of the present invention may form part of a fluid delivery system for delivery of a fluid from a fluid reservoir to a desired location. For example, the pump may be located in a housing with a fitting for attachment to a fluid reservoir. Thus, a fluid delivery system may comprise a housing having a fitting to which a fluid reservoir may be attached, such as by a screw- or push-fit. The housing may be openable and closable to allow for removal and replacement of a fluid reservoir. In embodiments, the carrier member of the pump may be formed integrally with a fitting for attachment to a fluid reservoir, which is removable from the fluid delivery system for replacement of the fluid reservoir. In these embodiments, the carrier member, fitting and/or fluid reservoir may all rotate together as a unit when the carrier member is ro-

tated by the compression roller. The fluid delivery system preferably comprises a motor for driving the pump. The fluid delivery system preferably comprises a fluid inlet, such as a tube or pipe, attached to the flexible tubing inlet, which in use is inserted into the fluid in the fluid reservoir when the fluid reservoir is attached to the housing. The fluid delivery system preferably further comprises a fluid outlet, such as a nozzle, tap, dropper or mixer, attached to the flexible tubing outlet, for delivery of the fluid to the desired location. In embodiments, the fluid delivery system outlet may comprise mixing means by which different fluids from different fluid reservoirs may be mixed on delivery to a desired location. For delivery of a beverage or beverage ingredient, the fluid delivery system may comprise a platform on which a beverage receptacle, such as a glass or bottle, may be placed so as to be positioned directly below the fluid outlet for delivery of the fluid into the receptacle.

[0016] The fluid delivery system may comprise flow prevention means, for preventing flow of fluid from the system, for example when a fluid reservoir is being replaced. Unwanted flow of fluid may be messy and present hygiene issues. The flow prevention means may comprise a clamp for clamping or pinching the flexible tubing to prevent fluid from exiting. The flow prevention means may comprise a clamp for clamping or pinching the flexible tubing to prevent fluid from exiting. In embodiments where the fluid reservoir is replaced by opening the housing of the fluid delivery system, the flow prevention means may be activated whenever the housing is opened, thereby clamping or pinching the flexible tubing to prevent fluid flow whilst the housing is open, releasing the flexible tubing when the housing is closed.

[0017] The fluid delivery system may comprise a controller, such as a programmable computer, for controlling fluid delivery. For example, the controller may be pre-programmed to deliver a predetermined amount of fluid or may deliver fluid in an amount determined by a user input, for example via user input means such as a touchscreen. The controller may control fluid delivery based upon other inputs from the system, for example in response to sensor inputs recognizing dead spots in fluid flow, e.g. from a microswitch, and adjust the run of the motor accordingly to take the dead spot(s) into account. The controller may comprise a computer memory for storing different user profiles each having particular fluid delivery preferences for that user. The controller may comprise wireless technology, e.g. smart technology, so as to be controllable by a user remotely (e.g. a smartphone app). The computer memory may be configured to store other information, such as the use history of the fluid delivery system, service history, and so forth.

[0018] The fluid delivery system may be useable with a plurality of fluid reservoirs simultaneously. Thus, for delivery of a beverage or beverage ingredient, the fluid delivery system may be able to deliver a plurality of different beverages or beverage ingredients, for example different flavourings, without a user needing to replace

the fluid reservoir. The fluid delivery system may comprise a single pump according to the present invention which is in fluid communication with each of a plurality of fluid reservoirs, or may comprise a plurality of pumps. For example, the fluid delivery system may comprise a plurality of pumps each of which is for use with a separate fluid reservoir. The fluid delivery system outlet may comprise, for example, mixing means for allowing a plurality of different fluids from different fluid reservoirs to be delivered mixed together.

[0019] Embodiments of the present invention will now be described in detail with reference to the accompanying drawings in which:

Figure 1 shows an embodiment of a pump, housing and fluid reservoir for use in a fluid delivery system according to the present invention;

Figure 2 shows the embodiment shown in Figure 1 with the housing removed;

Figure 3 shows the carrier member, flexible tubing and fluid reservoir of the embodiment shown in Figures 1 and 2;

Figure 4 shows an enlarged view of the carrier member and fitting of the embodiment shown in Figures 1 to 3;

Figure 5 shows the flexible tubing of the embodiment shown in Figures 1 to 4;

Figure 6 shows a cross-sectional view of Figure 4;

Figure 7 shows an enlarged view of the flexible tubing of the embodiment shown in Figures 1 to 6;

Figure 8 shows an enlarged view of the pump and housing shown in Figure 1 with the housing closed;

Figure 9 shows an enlarged view of the pump and housing shown in Figure 8 with the housing opened;

Figure 10 shows an enlarged view of the pump and housing shown in Figures 8 and 9 with the fluid reservoir, carrier member and flexible tubing detached from the housing;

Figure 11 shows an embodiment of a fluid delivery system array incorporating a plurality of embodiments of a fluid delivery system according to the present invention features of which are shown in Figures 1 to 10;

Figure 12 shows an exploded view of the fluid delivery system array as shown in Figure 11; and

Figure 13 shows an embodiment of a mixer nozzle

for use with the present invention.

[0020] Common reference numbers are used for the same features in each of the Figures. Not all features of the illustrated embodiments of the invention are shown in each of the Figures.

[0021] Referring to Figures 1 to 3, a pump (generally indicated by reference 1) according to the present invention is shown comprising a fluid inlet (not shown) and outlet 10. A further section of flexible tubing (not shown) will typically be attached to the outlet 10 to convey fluid from the pump 1 to the desired location. The pump 1 comprises a carrier member 12 and flexible tubing 14 extending around the outer surface of the carrier member 12 in a single turn. The pump 1 also comprises a drivable compression roller 16 which is shown in Figures 1 and 2 positioned against the carrier member 12 to compress the flexible tubing 14 therebetween. The compression roller 16 comprises an elongate cylinder and is rotated by a motor 18 to thereby cause the carrier member 12 and flexible tubing 14 to rotate, by which fluid within the flexible tubing 14 can be conveyed along the flexible tubing 14 through peristaltic action. Also shown are a fluid reservoir 20 which attaches to the carrier member 12 through a fitting 22, and a pump housing (generally indicated by reference 24 without a cover). The carrier member 12 engages with the housing 24 through engagement member 13, which projects from the upper surface of the carrier member 12. The engagement member 13 engages with a slot 50 (see Figures 9 and 10) in the underside of the housing 24 and is free to rotate within the slot 50 when the pump 1 is in use. In the embodiment shown in Figures 1 to 3, the carrier member 12, flexible tubing 14, fitting 22 and fluid reservoir 20 form a single unit, as shown in Figure 3, which is detachable from the pump housing 26, as is more fully described below with reference to Figures 8 to 10. Figure 1 also shows flow prevention means 26, for clamping a section of flexible tubing downstream of the pump outlet 10 for preventing fluid flow from the pump 1, for example when a fluid reservoir 20 is being replaced. The flow prevention means 26 is described further in more detail below with reference to Figures 8 to 10.

[0022] The motor 18 is able to drive the compression roller 12 both forwards and backwards, to dispense fluid to a desired location in a first direction, and in the second, opposite direction to allow fluid in the flexible tubing 14 to be returned to the fluid reservoir 20. Driving the compression roller 12 in the second direction also allows a cleaning fluid, such as water, to be drawn into the flexible tubing 14 to clean the flexible tubing 14 and thus help to prevent cross-contamination if the pump 1 is being used to deliver a plurality of different fluids.

[0023] Figure 4 shows an enlarged view of the carrier member 12 and fitting 22. Thus, the carrier member 12 is shown to have circumferential flanges 28 defining a circumferential channel 30 in which the flexible tubing 14 (not shown in Figure 4) is carried by the carrier member

12. Figure 4 also shows an inlet tube 32 which extends within the fluid reservoir 20 (not shown in Figure 4) through which fluid enters the fluid delivery device.

[0024] Figures 5 to 7 show the connections between the inlet tube 32, flexible tubing 14, carrier member 12 and outlet 10 in more detail. Thus, the elongate inlet tube 32 has an inlet end 34 which extends within the fluid reservoir 20 (not shown) and an outlet end 36 which connects to the inlet of the flexible tubing 14 at inlet junction 38. The flexible tubing 14 extends in a single coil around the circumference of the carrier member 12 within channel 30 defined by flanges 28. The flexible tubing outlet 40 connects to a movable rotary joint 44 at outlet junction 42. The movable rotary joint 44 is positioned within the engagement member 13 and is in fluid-tight communication with the pump outlet 10 through O-ring 46. The movable rotary joint 44 allows for relative rotation between the flexible tubing 14 about the rotational axis of the carrier member 12 and the outlet 10, to allow the outlet 10 to remain in a fixed position as the carrier member 12 rotates. Figure 6 also shows screw threads 48 by which the fitting 22 attaches to the fluid reservoir 20 (not shown in Figure 6).

[0025] Figures 8 to 10 show how a fluid reservoir 20 may be detached from the housing 24, for example to replace an empty reservoir 20. Thus, Figure 8 shows the fluid reservoir 20 attached to the housing 24, with the housing 24 in a closed position. Figure 9 shows the housing 24 in an open position, in which the outlet 10 is detached from the movable rotary joint 44 within the carrier member 12. Figure 9 shows the engagement member 13 held within the slot 50 on the underside of the housing 24. When the housing 24 is in the open position, the engagement member 13 may be removed from the slot 50 and the unit comprising the carrier member 12 and fluid reservoir 20 may be removed as shown in Figure 10.

[0026] Figures 8 to 10 also illustrate operation of the flow prevention means 26. As shown, the flow prevention means comprises a clamp through which a further section of flexible tubing (not shown) for conveying fluid from the outlet 10 to the desired location would be held. When the housing 24 is in the closed position, as shown in Figure 8, the flow prevention means is not activated and the flexible tubing is unconstricted within the flow prevention means 26 so that fluid can be conveyed therethrough. However, when the housing 24 is in the open position, as shown in Figures 9 and 10, the flow prevention means moves upwards relative to the flexible tubing, which causes a constriction within the flexible tubing and thereby prevents fluid from flowing within the flexible tubing whilst the housing 24 is in the open position. When the housing 24 is returned to the closed position, as shown in Figure 8, the flow prevention means 26 returns to the non-activated position, and fluid can once again flow through the flexible tubing.

[0027] Figures 11 and 12 show an array 100 of seven individual fluid delivery systems 102 according to the present invention, features of which are described with

reference to Figures 1 to 10. In this embodiment, each of the individual fluid delivery systems 102 is identical, and thus for ease of reference, reference numerals are provided in each Figure for one individual fluid delivery system 102 of the array 100 only. However, it will be understood that each of the individual fluid delivery systems 102 has the same features.

[0028] Thus, the illustrated embodiment of a fluid delivery system array 100 comprises seven individual fluid delivery systems 102, each of which comprises a fluid reservoir 22, a housing 24 and housing cover 52, and pump 1. However, it is to be understood that the fluid delivery systems 102 may be used individually, or in an array containing any desired number of fluid delivery systems 102. The housings 24 are shown having covers 52. The array 100 is held within a casing 56 which comprises a backplate 58 and a front plate 60. The casing 56 also comprises platforms 54 upon which the fluid reservoirs 20 rest when the units comprising the carrier member 12 and fluid reservoirs 20 are attached to the housings 24.

[0029] A fluid delivery system array 100 allows for a plurality of different fluids to be delivered to a desired location. For example, in the case of beverages, each of the fluid reservoirs 20 may contain a different beverage or beverage additive, such as a flavouring. Each fluid delivery system 102 is in fluid communication with an outlet for delivering fluid to a desired location, for example by flexible tubing. Each fluid delivery system 102 may be individually and separately in fluid communication with the outlet, or a plurality of fluid delivery systems may be commonly in fluid communication with the outlet, for example through a shared flexible tubing. As discussed herein, in the illustrated embodiment, each of the individual fluid delivery systems 102 of the array 100 has its own pump 1, but a plurality of fluid delivery systems 102 may share a common pump 1.

[0030] Figure 13 shows an embodiment of a mixer nozzle 200 for use with the present invention. The mixer nozzle 200 comprises a mixing chamber 204 having a plurality of chamber inlets 202. The inlets 202 will typically be connected to one or more fluid delivery systems 102, for example an array 100, as described herein, for mixing different fluids. The mixer nozzle 200 further comprises an elongate outlet pipe 206, which may be positioned at a desired location for delivery of the fluid, for example within a receptacle or bottle in the case of a beverage. The mixer nozzle 200 comprises an outlet 208 for delivery of the fluid.

Claims

1. A peristaltic pump (1) comprising:

a fluid inlet and outlet (10);
a carrier member (12) having an outer surface;
flexible tubing (14) for conveying a fluid which extends at least partially around the outer sur-

face of the carrier member; and
a drivable compression roller (16);
wherein the carrier member and compression roller are positioned adjacent one another to compress the flexible tubing therebetween;
characterized in that the compression roller is rotatable about an axis of rotation to thereby cause the carrier member and flexible tubing to rotate about an axis of rotation, by which fluid within the flexible tubing can be conveyed along the flexible tubing between the inlet and outlet.

2. A pump according to claim 1 wherein the circumference of the compression roller is less than the circumference of the carrier member.

3. A pump according to claim 2 wherein the ratio of the circumference of the compression roller to the carrier member is from 1:10 to 1:15 or 1:20.

4. A pump according to any preceding claim wherein the flexible tubing extends around the carrier member as a single turn coil.

5. A pump according to any preceding claim wherein the flexible tubing is connected to the pump outlet via a fluid-tight movable joint (44).

6. A pump according to any preceding claim wherein a fluid flow path comprises an inlet comprising a pipe or tube (32) which in use is in fluid communication with a fluid source and also with the flexible tubing, and the flexible tubing extends from the inlet around the circumference of the carrier member to the pump outlet via a fluid-tight movable joint.

7. A pump according to any preceding claim wherein the carrier member comprises circumferential flanges (28) to retain the flexible tubing in position and the compression roller has a thickness selected so the compression roller sits between the flanges to compress the flexible tubing, or the compression roller comprises an elongate cylinder which can press against the flanges to compress the flexible tubing within the flanges.

8. A pump according to any preceding claim wherein the pump is configured to recognize any interruptions to the continuous flow of fluid through the flexible tubing, and adjust the driving of the compression roller to take the interruption into account.

9. A fluid delivery system (102) comprising a pump according to any preceding claim.

10. A fluid delivery system according to claim 9 comprising a housing (24) which is openable and closable to allow for removal and replacement of a fluid res-

ervoir (20), and wherein the carrier member of the pump comprises a fitting (22) for attachment to a fluid reservoir, and wherein the carrier member, fitting and/or fluid reservoir all rotate together as a unit when the carrier member is rotated by the compression roller.

11. A fluid delivery system according to claim 9 or 10 comprising fluid outlet comprising a nozzle, tap, dropper or mixer.
12. A fluid delivery system according to claim 11 which comprises mixing means (200) by which different fluids from different fluid reservoirs may be mixed on delivery to a desired location.
13. A fluid delivery system according to any one of claims 9 to 12 comprising flow prevention means (26), for preventing flow of fluid from the system.
14. A fluid delivery system according to claim 13 wherein the flow prevention means comprises a clamp for clamping or pinching the flexible tubing to prevent fluid from exiting, and/or wherein the fluid delivery system comprises a housing wherein the flow prevention means is activated whenever the housing is opened, and deactivated when the housing is closed.
15. A fluid delivery system according to any one of claims 9 to 14 comprising a controller for controlling fluid delivery, wherein the controller is configured to be pre-programmed to deliver a predetermined amount of fluid and/or to deliver fluid in an amount determined by a user input, and/or wherein the controller comprises a computer memory for storing different user profiles each having particular fluid delivery preferences for that user.

Patentansprüche

1. Eine Schlauchpumpe (1) umfassend:

Einen Fluideinlass und -auslass (10);
 ein Trägererelement (12) mit einer Außenfläche;
 einen flexiblen Schlauch (14) für das Befördern eines Fluids, der sich mindestens teilweise um die Außenfläche des Trägererelements erstreckt;
 und
 eine antreibbare Kompressionsrolle (16);
 wobei das Trägererelement und die Kompressionsrolle nebeneinander positioniert sind, um den flexiblen Schlauch dazwischen zusammenzupressen;
gekennzeichnet dadurch, dass die Kompressionsrolle drehbar um eine Rotationsachse angebracht ist, um dadurch das Trägererelement und den flexiblen Schlauch zu veranlassen, sich

um eine Rotationsachse zu drehen, wodurch ein Fluid in dem flexiblen Schlauch entlang des flexiblen Schlauchs zwischen dem Einlass und Auslass befördert werden kann.

- 5
2. Pumpe nach Anspruch 1, wobei der Umfang der Kompressionsrolle geringer ist als der Umfang des Trägererelements.
- 10
3. Pumpe nach Anspruch 2, wobei das Verhältnis des Umfangs der Kompressionsrolle zu dem Trägererelement bei 1:10 bis 1:15 oder 1:20 liegt.
- 15
4. Pumpe nach einem der vorstehenden Ansprüche, wobei sich der flexible Schlauch als Einzelwindungsspule um das Trägererelement erstreckt.
- 20
5. Pumpe nach einem der vorstehenden Ansprüche, wobei der flexible Schlauch über eine fluiddichte, bewegliche Verbindung (44) mit dem Pumpenauslass verbunden ist.
- 25
6. Pumpe nach einem der vorstehenden Ansprüche, wobei ein Fluidfließweg einen Einlass mit einem Rohr oder einem Schlauch (32) umfasst, der im Betrieb in Fluidverbindung mit einer Fluidquelle und auch dem flexiblen Schlauch steht, und der flexible Schlauch sich von dem Einlass um den Umfang des Trägererelements zu dem Pumpenauslass über eine fluiddichte, bewegliche Verbindung erstreckt.
- 30
7. Pumpe nach einem der vorstehenden Ansprüche, wobei das Trägererelement Umfangsflansche (28) umfasst, um den flexiblen Schlauch in Position zu halten, und die Kompressionsrolle eine Dicke aufweist, die so ausgewählt ist, dass die Kompressionsrolle zwischen den Flanschen sitzt, um den flexiblen Schlauch zusammenzupressen, oder die Kompressionsrolle einen länglichen Zylinder umfasst, der gegen die Flansche drücken kann, um den flexiblen Schlauch innerhalb der Flansche zusammenzupressen.
- 35
8. Pumpe nach einem der vorstehenden Ansprüche, wobei die Pumpe konfiguriert ist, jede Unterbrechung des kontinuierlichen Fluidstroms durch den flexiblen Schlauch zu erkennen und den Antrieb der Kompressionsrolle einzustellen, um die Unterbrechung zu berücksichtigen.
- 40
9. Fluidzuführsystem (102) umfassend eine Pumpe nach einem der vorstehenden Ansprüche.
- 45
10. Fluidzuführsystem nach Anspruch 9, umfassend ein Gehäuse (24), das betriebsbereit und verschließbar ist, um das Entnehmen und Austauschen eines Fluidbehälters (20) zu erlauben und wobei das Trägererelement der Pumpe eine Fassung (22) für das Be-
- 50
- 55

festigen an einem Fluidbehälter umfasst, und wobei sich das Trägerelement, die Fassung und/oder der Fluidbehälter zusammen als eine Einheit drehen, wenn das Trägerelement durch die Kompressionsrolle gedreht wird.

11. Fluidzuführsystem nach Anspruch 9 oder 10, umfassend einen Fluidauslass mit einer Düse, einem Hahn, einer Pipette oder einer Mischbatterie.
12. Fluidzuführsystem nach Anspruch 11, das eine Mischeinrichtung (200) umfasst, durch die verschiedene Fluide aus verschiedenen Fluidbehältern gemischt und an einen gewünschten Ort geleitet werden können.
13. Fluidzuführsystem nach einem der Ansprüche 9 bis 12, das eine Durchfluss-Sperrvorrichtung (26) umfasst, um einen Fluidfluss aus dem System zu verhindern.
14. Fluidzuführsystem nach Anspruch 13, wobei die Durchfluss-Sperrvorrichtung eine Klemme umfasst, um den flexiblen Schlauch abzuklemmen oder zusammenzudrücken und zu verhindern, dass ein Fluid herausläuft und/oder wobei das Fluidzuführsystem ein Gehäuse umfasst, wobei die Durchfluss-Sperrvorrichtung immer dann aktiviert wird, wenn das Gehäuse geöffnet ist, und deaktiviert wird, wenn das Gehäuse geschlossen ist.
15. Fluidzuführsystem nach einem der Ansprüche 9 bis 14, umfassend eine Steuereinheit für das Steuern der Fluidzufuhr, wobei die Steuereinheit so konfiguriert ist, dass sie vorprogrammiert werden kann, um eine vorbestimmte Menge an Fluid zuzuführen und/oder Fluid in einer durch eine Benutzereingabe bestimmten Menge zuzuführen, und/oder wobei die Steuereinheit einen Computerspeicher umfasst, um verschiedene Nutzerprofile zu speichern, die jeweils bestimmte Fluidzuführpräferenzen für diesen Benutzer aufweisen.

Revendications

1. Pompe péristaltique (1) comprenant :

une entrée et une sortie de fluide (10) ;
 un élément porteur (12) présentant une surface extérieure ;
 un tube flexible (14) destiné à transporter un fluide qui s'étend au moins partiellement autour de la surface extérieure de l'élément porteur ; et
 un rouleau de compression (16) pouvant être entraîné ;
 dans lequel l'élément porteur et le rouleau de compression sont positionnés adjacents l'un à

l'autre pour comprimer le tube flexible entre eux ;

caractérisée en ce que le rouleau de compression peut tourner autour d'un axe de rotation pour amener ainsi la rotation de l'élément porteur et du tube flexible autour d'un axe de rotation, par lequel le fluide contenu dans le tube flexible peut être transporté le long du tube flexible entre l'entrée et la sortie.

5

10

15

20

25

30

35

40

45

50

55

2. Pompe selon la revendication 1, dans laquelle la circonférence du rouleau de compression est inférieure à la circonférence de l'élément porteur.

3. Pompe selon la revendication 2, dans laquelle le rapport de la circonférence du rouleau de compression à l'élément porteur est de 1:10 à 1:15 ou 1:20.

4. Pompe selon une quelconque revendication précédente, dans laquelle le tube flexible s'étend autour de l'élément porteur sous la forme d'une bobine à spire unique.

5. Pompe selon une quelconque revendication précédente, dans laquelle le tube flexible est raccordé à la sortie de la pompe par l'intermédiaire d'un joint mobile étanche (44).

6. Pompe selon une quelconque revendication précédente, dans laquelle un trajet d'écoulement de fluide comprend une entrée comprenant un tuyau ou un tube (32) qui, lors de l'utilisation, est en communication fluïdique avec une source de fluide et également avec le tube flexible et le tube flexible s'étend depuis l'entrée autour de la circonférence de l'élément porteur jusqu'à la sortie de la pompe par l'intermédiaire d'un joint mobile étanche.

7. Pompe selon une quelconque revendication précédente, dans laquelle l'élément porteur comprend des brides circonférentielles (28) pour retenir le tube flexible en position et le rouleau de compression présente une épaisseur choisie de sorte que le rouleau de compression se trouve entre les brides pour comprimer le tube flexible, ou le rouleau de compression comprend un cylindre allongé qui peut presser contre les brides pour comprimer le tube flexible à l'intérieur des brides.

8. Pompe selon une quelconque revendication précédente, dans laquelle la pompe est conçue pour reconnaître toute interruption de l'écoulement continu de fluide à travers le tube flexible, et pour ajuster l'entraînement du rouleau de compression pour prendre en compte l'interruption.

9. Système de distribution de fluide (102) comprenant une pompe selon une quelconque revendication pré-

cédente.

- 10.** Système de distribution de fluide selon la revendication 9, comprenant un logement (24) qui peut être ouvert et fermé pour permettre le retrait et le remplacement d'un réservoir de fluide (20) et dans lequel l'élément porteur de la pompe comprend un raccord (22) destiné à la fixation à un réservoir de fluide et dans lequel l'élément porteur, le raccord et/ou le réservoir de fluide tournent tous ensemble comme une unité lorsque l'élément porteur est mis en rotation par le rouleau de compression. 5 10
- 11.** Système de distribution de fluide selon la revendication 9 ou 10, comprenant une sortie de fluide comprenant une buse, un robinet, un compte-gouttes ou un mélangeur. 15
- 12.** Système de distribution de fluide selon la revendication 11, qui comprend un moyen de mélange (200) par lequel différents fluides provenant de différents réservoirs de fluide peuvent être mélangés lors de la livraison à l'emplacement souhaité. 20
- 13.** Système de distribution de fluide selon l'une quelconque des revendications 9 à 12, comprenant un moyen de prévention d'écoulement (26), destiné à empêcher l'écoulement de fluide à partir du système. 25
- 14.** Système de distribution de fluide selon la revendication 13, dans lequel le moyen de prévention d'écoulement comprend une bride servant à serrer ou à pincer le tube flexible pour empêcher le fluide de sortir, et/ou dans lequel le système de distribution de fluide comprend un logement dans lequel le moyen de prévention d'écoulement est activé chaque fois que le logement est ouvert et désactivé est activé chaque fois que le logement est fermé. 30 35
- 15.** Système de distribution de fluide selon l'une quelconque des revendications 9 à 14, comprenant un dispositif de commande destiné à commander la distribution de fluide, dans lequel le dispositif de commande est conçu pour être préprogrammé afin de délivrer une quantité prédéfinie de fluide et/ou pour délivrer un fluide suivant une quantité définie par une entrée d'utilisateur, et/ou dans lequel le dispositif de commande comprend une mémoire d'ordinateur destinée à mémoriser différents profils utilisateurs présentant chacun des préférences de distribution de fluide particulières pour cet utilisateur. 40 45 50

55

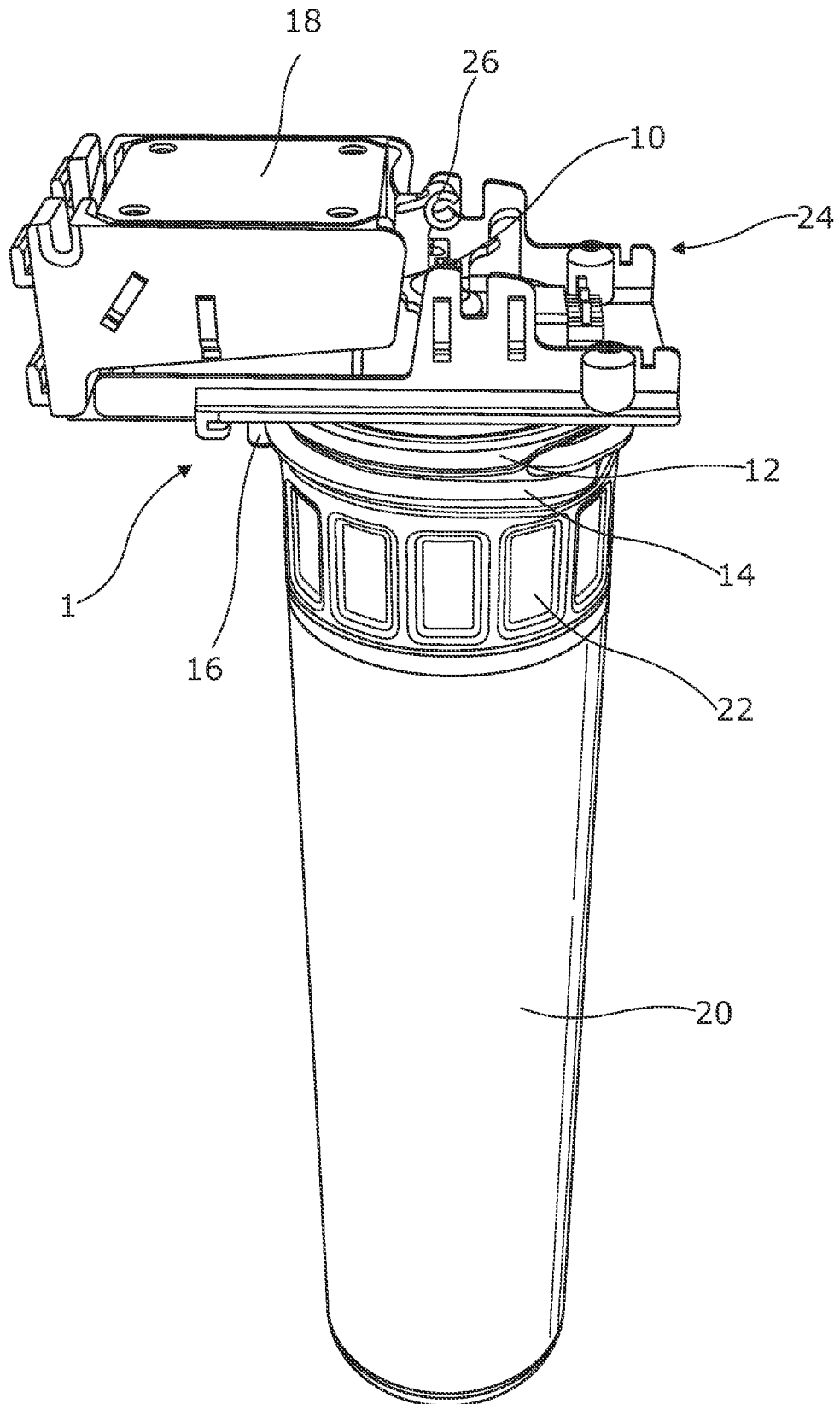

Figure 1

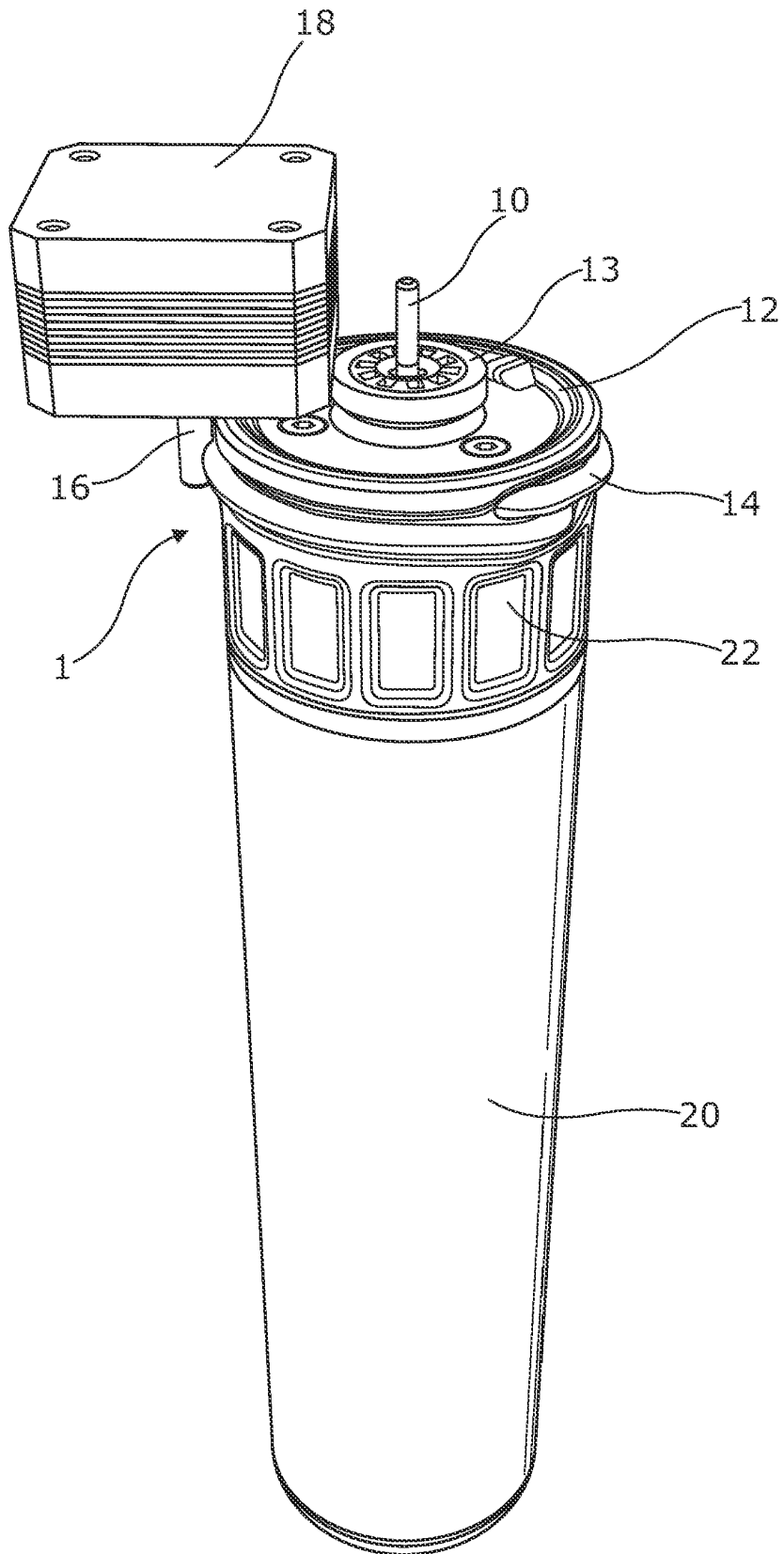

Figure 2

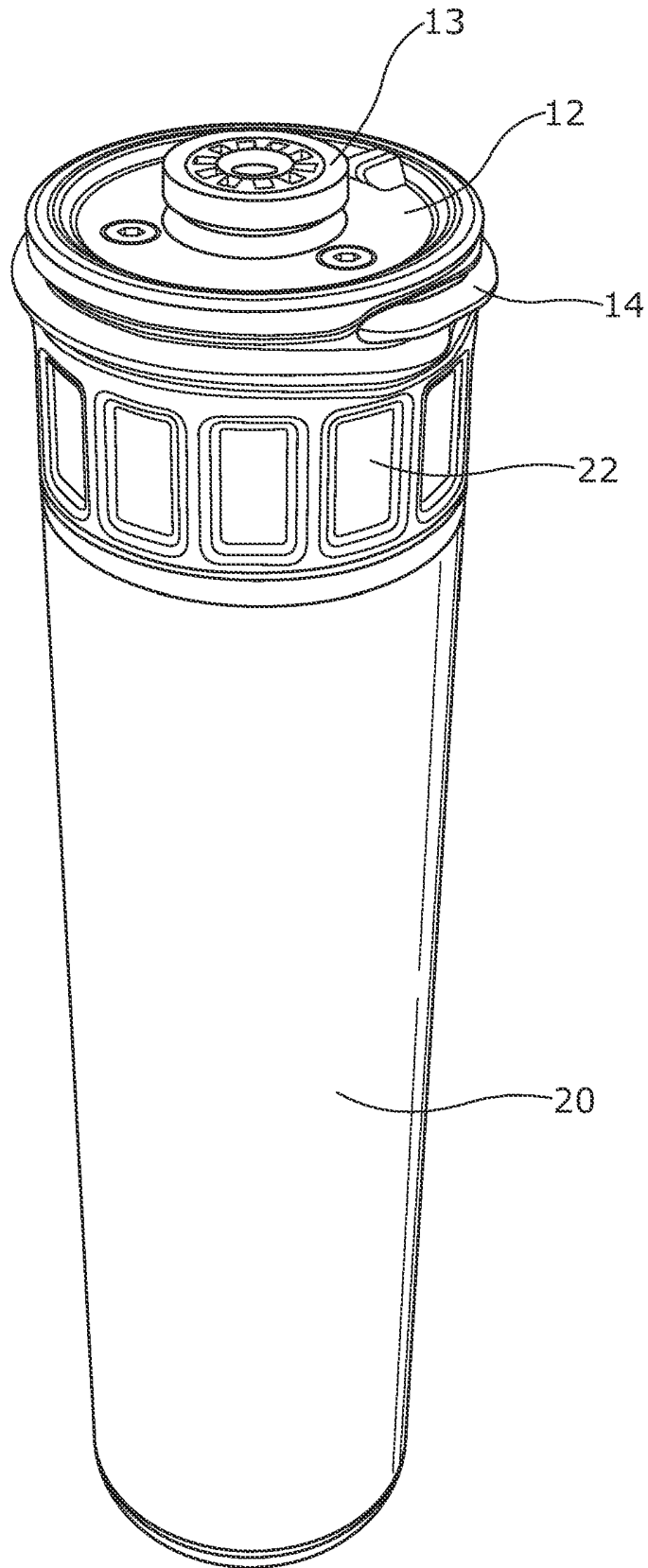

Figure 3

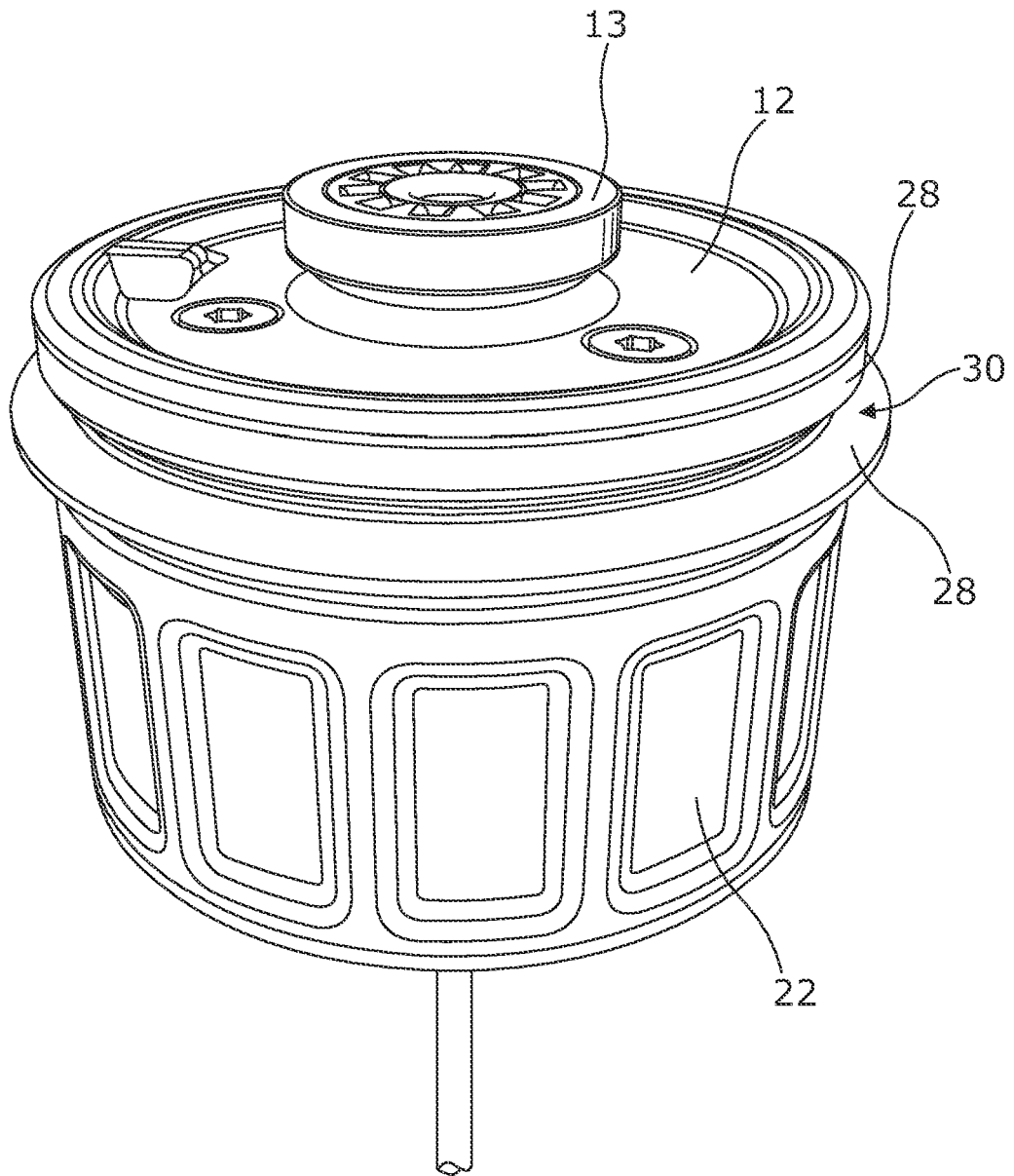

Figure 4

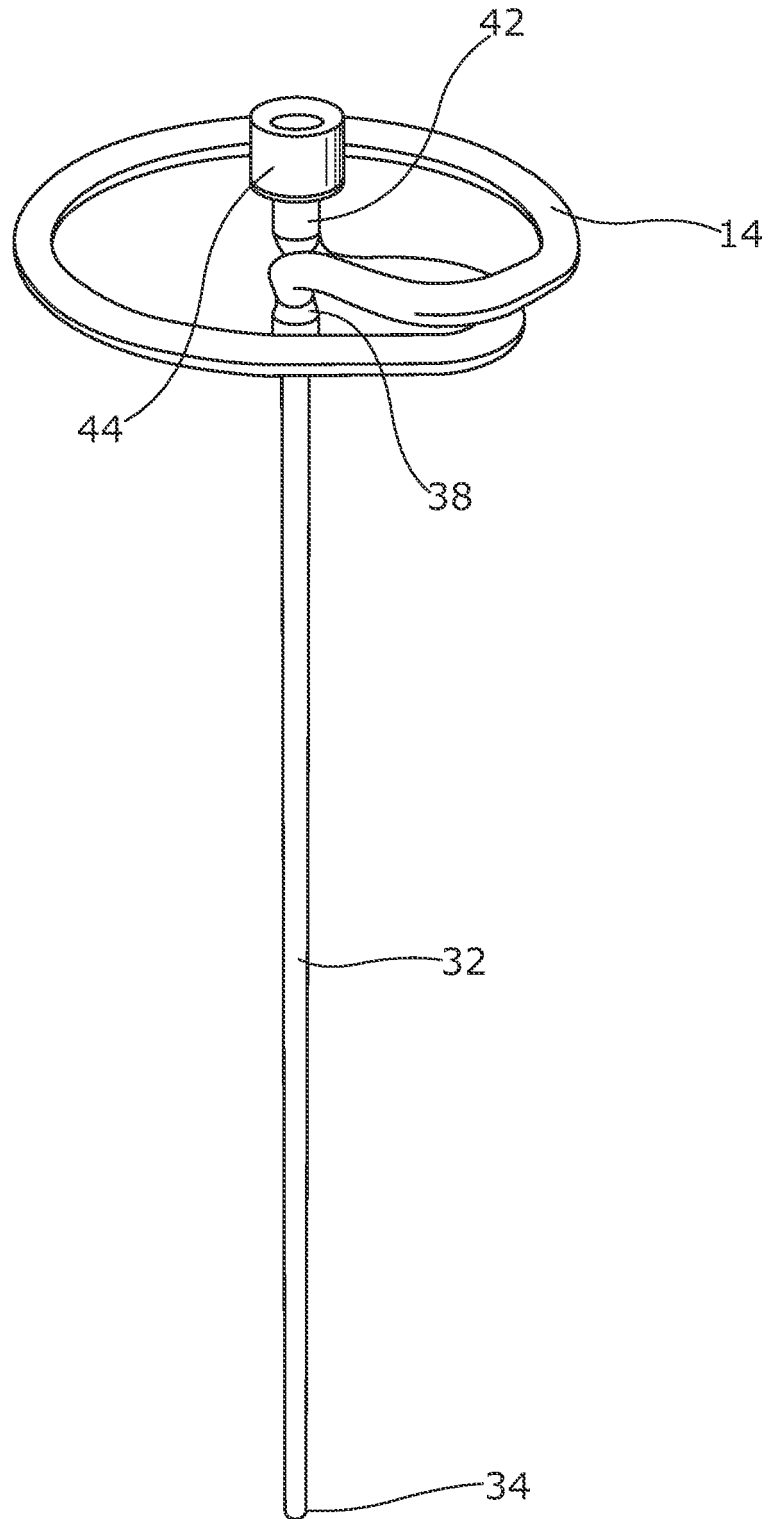

Figure 5

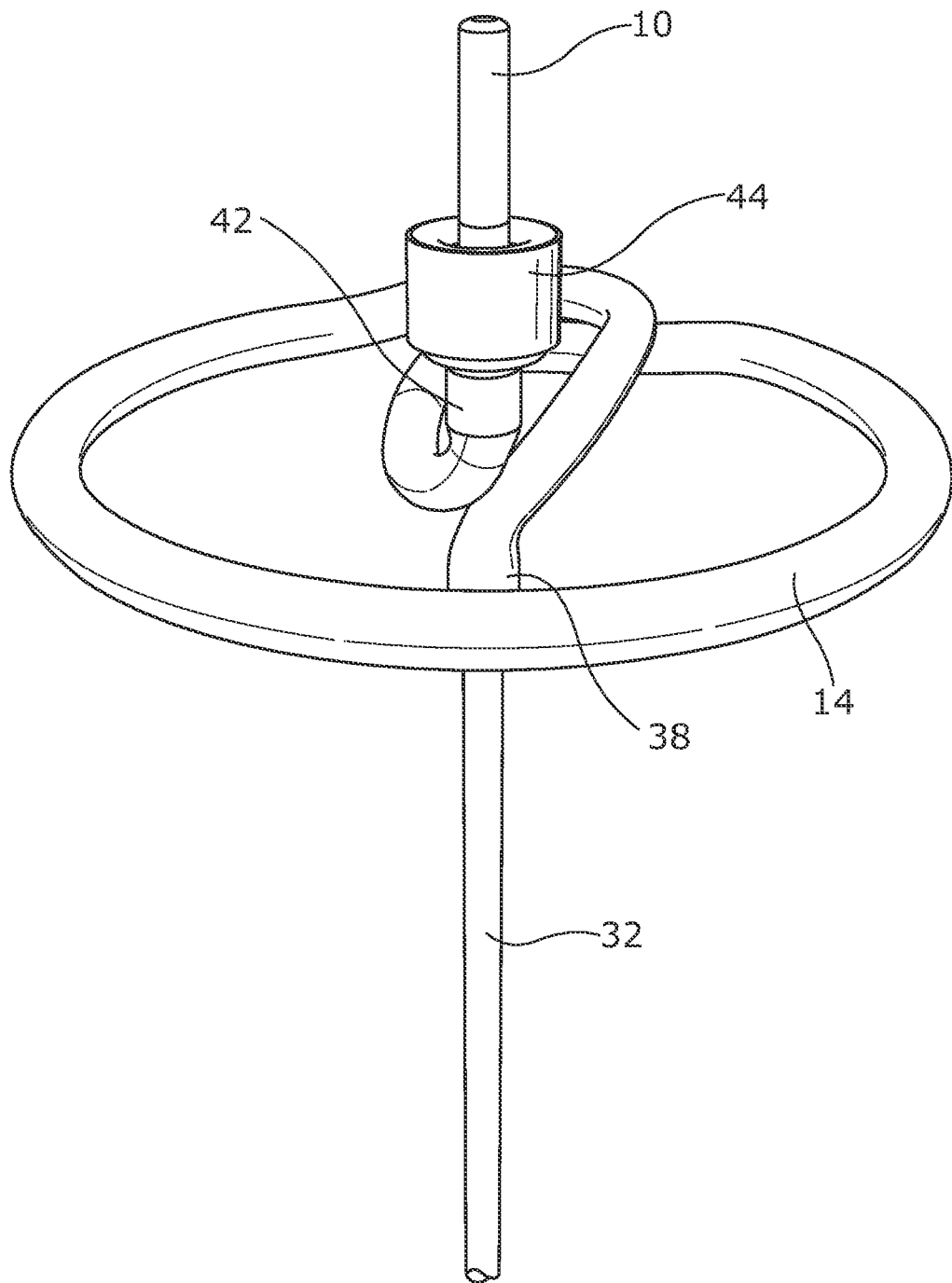

Figure 7

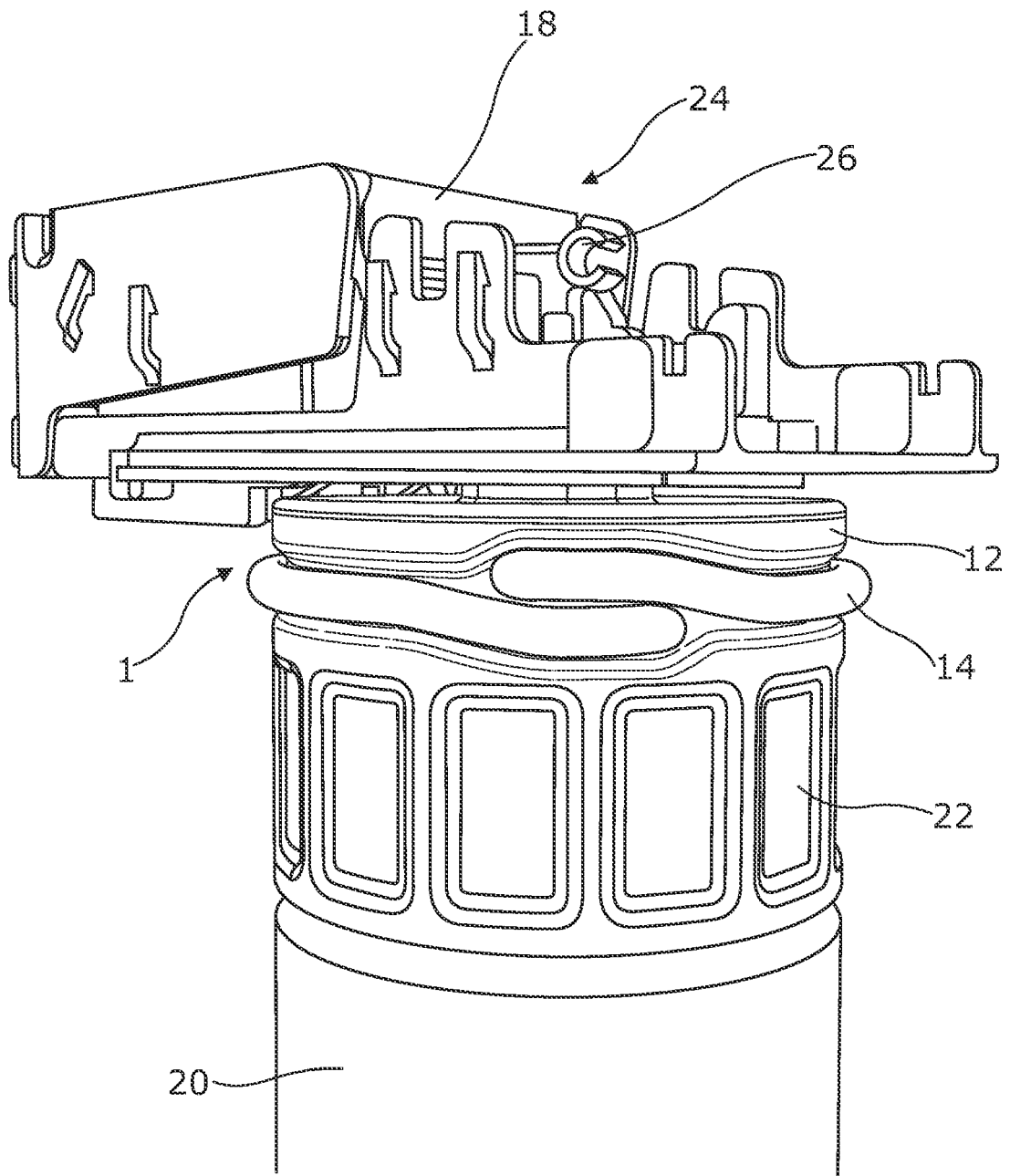

Figure 8

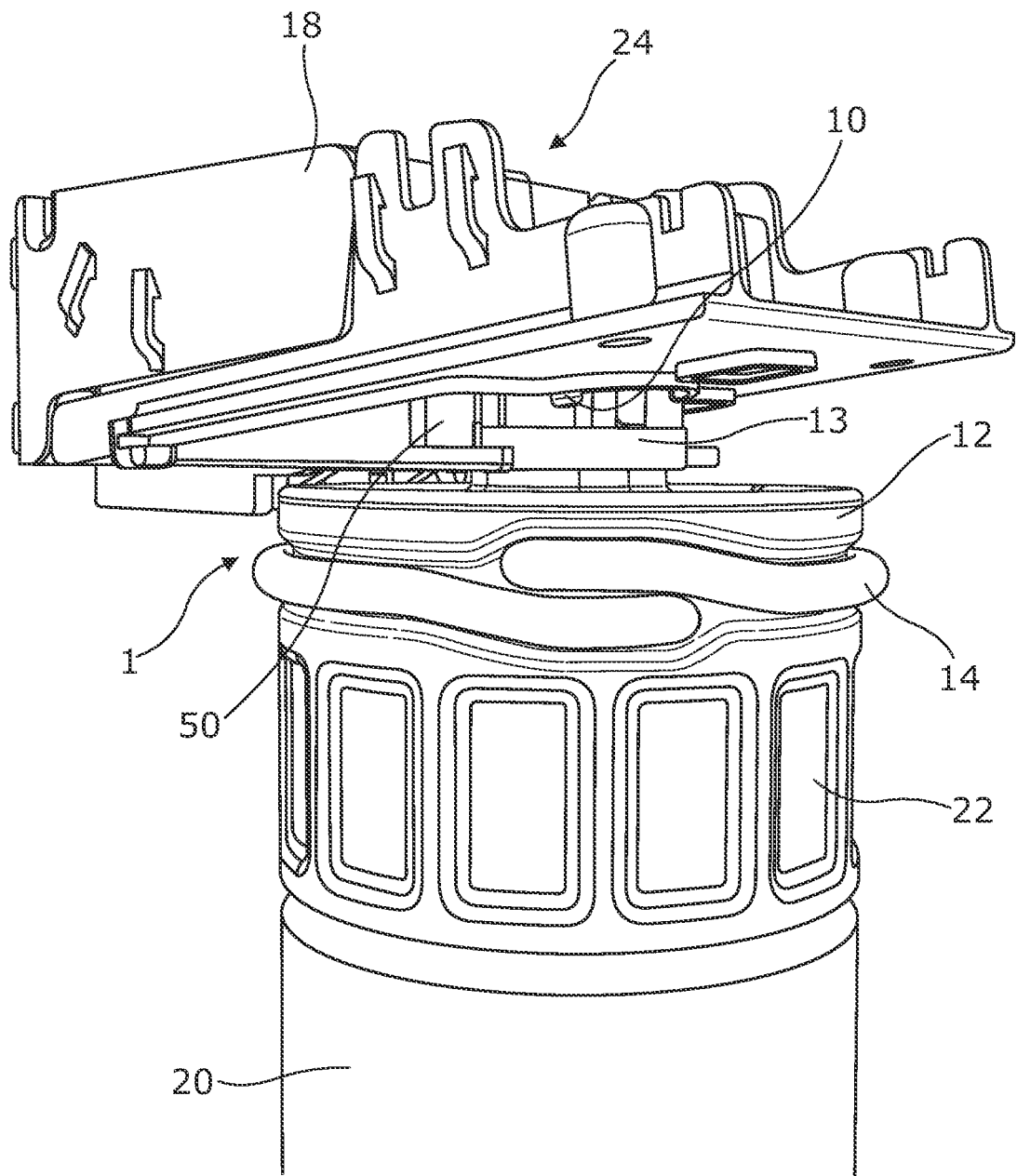

Figure 9

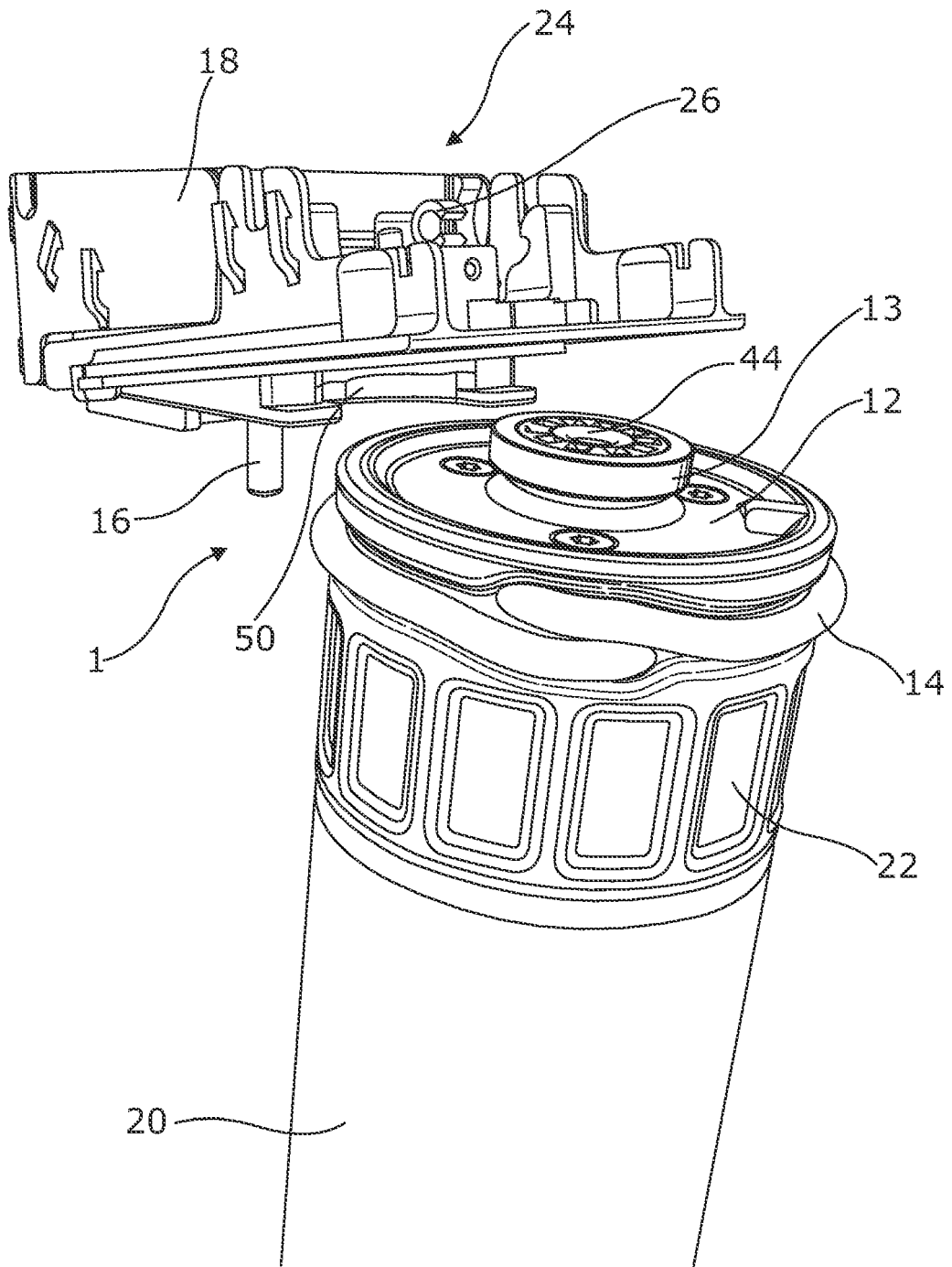

Figure 10

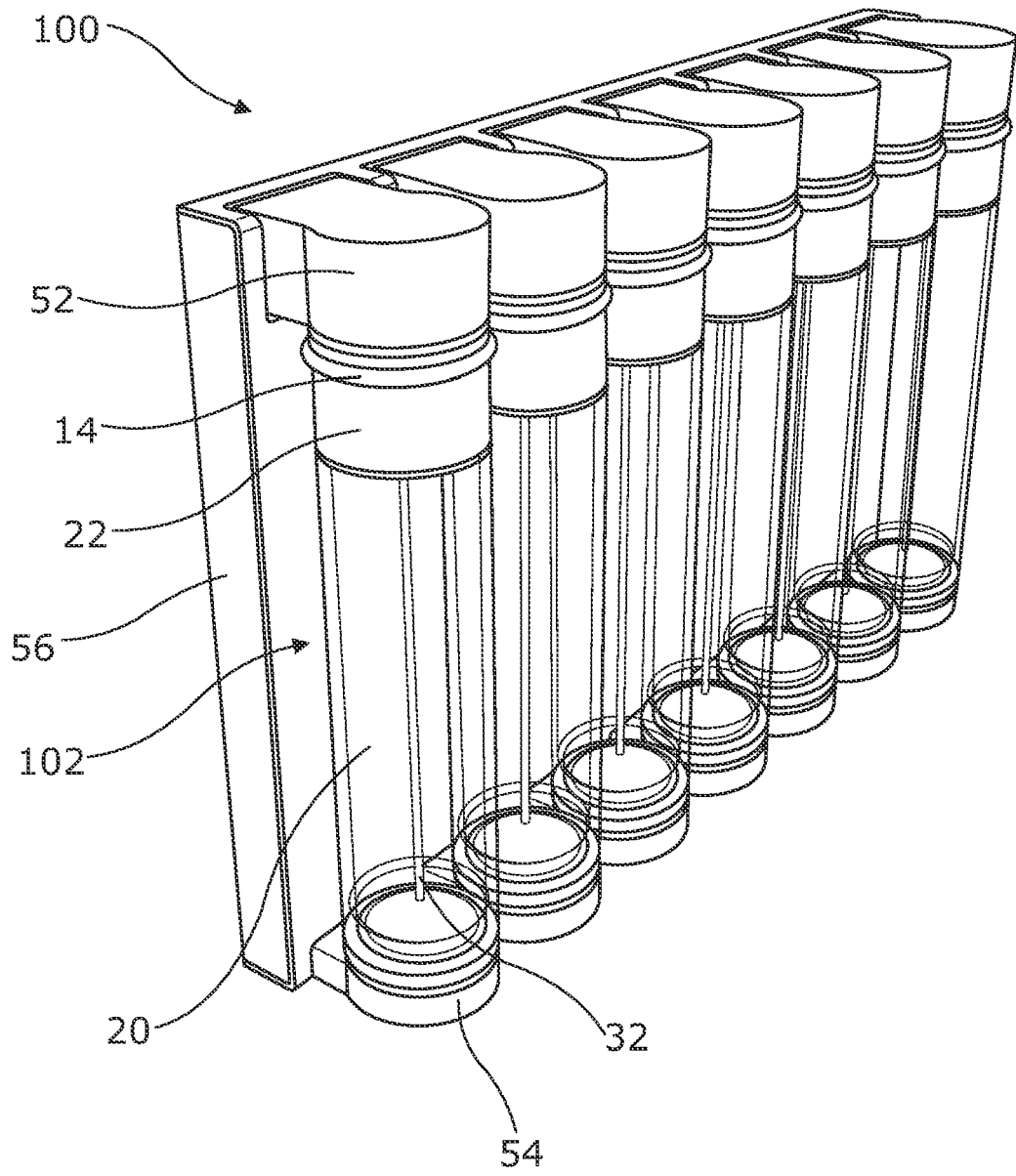

Figure 11

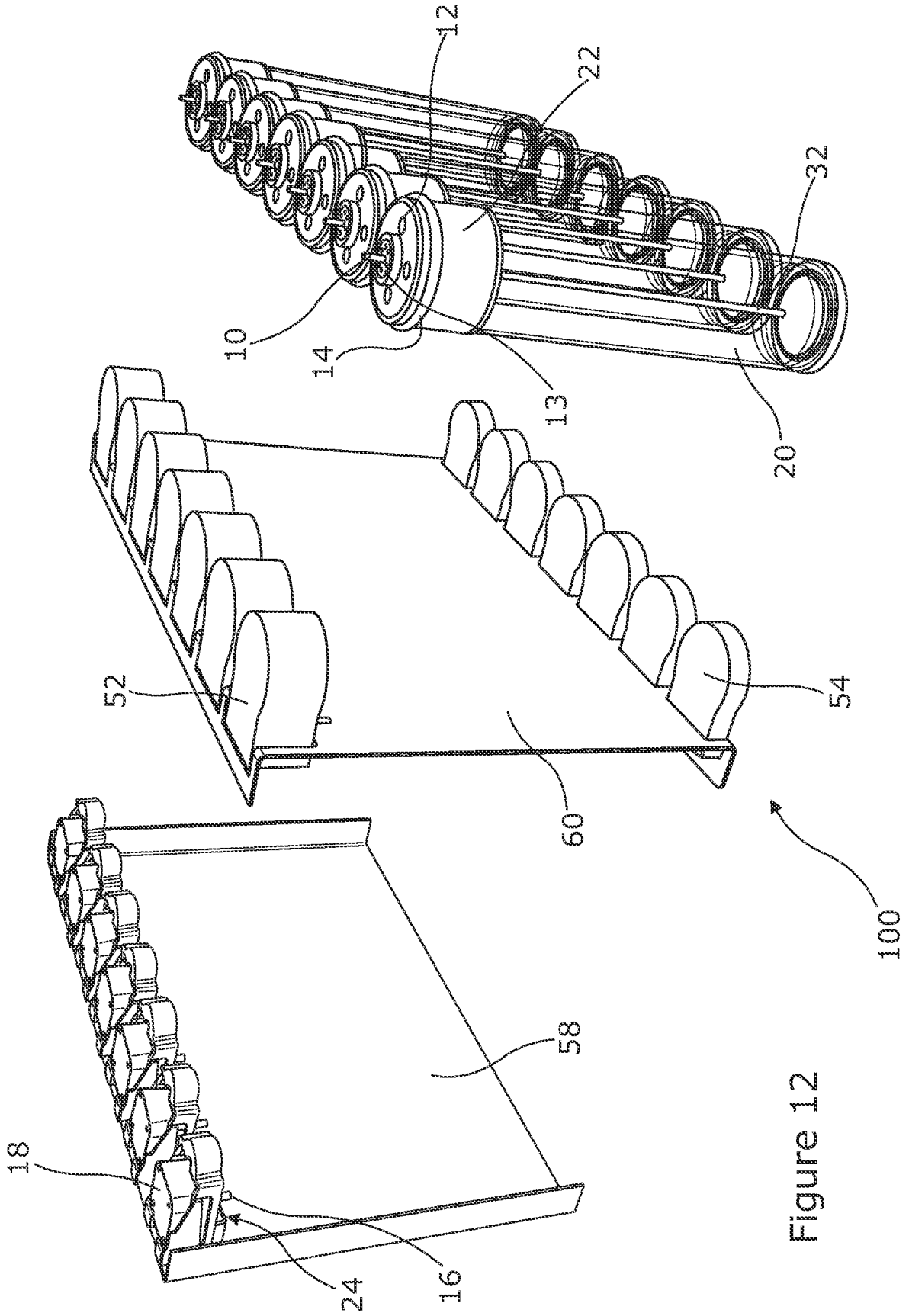

Figure 12

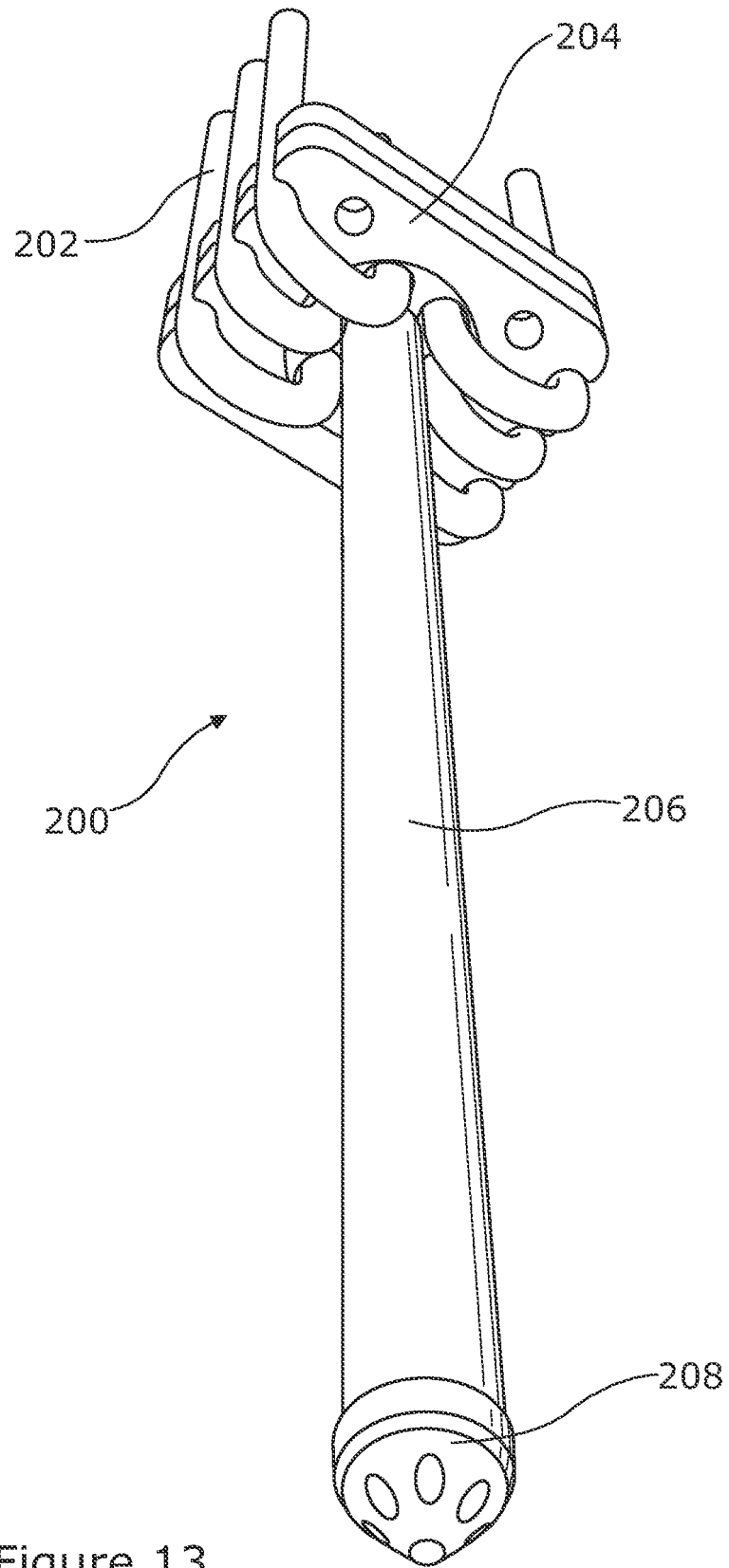

Figure 13

REFERENCES CITED IN THE DESCRIPTION

This list of references cited by the applicant is for the reader's convenience only. It does not form part of the European patent document. Even though great care has been taken in compiling the references, errors or omissions cannot be excluded and the EPO disclaims all liability in this regard.

Patent documents cited in the description

- GB 2128262 A [0004]