

(19)



(11)

EP 4 267 482 B1

(12)

EUROPEAN PATENT SPECIFICATION

(45) Date of publication and mention of the grant of the patent:

16.10.2024 Bulletin 2024/42

(21) Application number: **21830507.6**

(22) Date of filing: **03.12.2021**

(51) International Patent Classification (IPC):

B65D 41/32^(2006.01) B65D 41/34^(2006.01)

(52) Cooperative Patent Classification (CPC):

B65D 41/325; B65D 41/3428; B65D 2401/15; B65D 2401/35

(86) International application number:

PCT/IB2021/061281

(87) International publication number:

WO 2022/136985 (30.06.2022 Gazette 2022/26)

(54) **CLOSURE WITH TEAR-OFF SEAL**

VERSCHLUSS MIT ABREISSVERSCHLUSS

FERMETURE DOTÉE D'UNE CAPSULE DÉCHIRABLE

(84) Designated Contracting States:

AL AT BE BG CH CY CZ DE DK EE ES FI FR GB GR HR HU IE IS IT LI LT LU LV MC MK MT NL NO PL PT RO RS SE SI SK SM TR

(30) Priority: **22.12.2020 IT 202000031778**

(43) Date of publication of application:

01.11.2023 Bulletin 2023/44

(73) Proprietor: **Guala Closures S.p.A.**

15122 Alessandria (AL) (IT)

(72) Inventors:

- **GIOVANNINI, Marco**
2152 Luxembourg (LU)

• **VIALE, Luca**

15122 Alessandria AL (IT)

(74) Representative: **Perani & Partners S.p.A.**

Piazza Armando Diaz, 7
20123 Milano (IT)

(56) References cited:

EP-B1- 2 822 869	CN-Y- 201 176 292
DE-A1- 102014 011 539	US-A- 5 667 086
US-A1- 2005 092 751	US-A1- 2015 014 316
US-A1- 2016 167 840	

EP 4 267 482 B1

Note: Within nine months of the publication of the mention of the grant of the European patent in the European Patent Bulletin, any person may give notice to the European Patent Office of opposition to that patent, in accordance with the Implementing Regulations. Notice of opposition shall not be deemed to have been filed until the opposition fee has been paid. (Art. 99(1) European Patent Convention).

Description

Field of the invention

[0001] The present invention relates to a closure with a tear-off seal.

[0002] Closures with tear-off seals are known in the art. These closures generally include a cap proper, which is removably associated with the rest of the closure, and an element for providing first-opening evidence.

State of the art

[0003] GB 2 285 623 discloses a closure which comprises a pouring device 16 defining a pouring orifice, a skirt for fixing the pouring device to the neck of the container, a cap adapted to engage and disengage the pouring device to close the pouring orifice and a hood that permanently surrounds the skirt and the cap and has an annular portion permanently engaging a lower portion of the skirt. The hood comprises a tear strip which is configured to leave the annular portion engaged with the skirt when the tear strip is torn off, to provide evidence that the closure has been opened for the first time.

[0004] EP 1 818 272 describes a closure comprising a cap adapted to engage and disengage the pouring orifice of a pouring device fixed to the mouth of a container and a hood surrounding the cap and having an annular portion that stably engages the neck of the container. The hood comprises a tear-off tab which is configured to leave the annular portion engaged with the neck of the container when the tear-off tab is torn to provide evidence that the closure has been opened for the first time.

[0005] US 5,667,086 describes a tamper-evident closure which comprises a cap connected via a breakable portion to a skirt fixed to the neck of a container and a hood which surrounds the cap and, via the skirt of the cap, is fixed to the neck of the container. The hood comprises a lower portion and an upper portion. The upper portion is equipped with a tear-off tab which, when torn, allows removal of the upper portion, leaving the lower portion fixed to the skirt of the cap and, as a result, to the neck of the container.

[0006] The aforementioned closures have the drawback of not being immune to fraudulent acts committed by a counterfeiter who wants to restore the closures to the configuration prior to the first opening.

[0007] A counterfeiter can remove in a relatively easy manner not only the part that is rigidly joined to the tab but also the part remaining on the container. Then, the counterfeiter can open the cap, replace the contents of the container with other contents of poor quality, close the cap and apply a new hood with a tear-off seal, thereby restoring the closure and the container exactly in the configuration prior to the first opening.

[0008] Even the provision of the breakable portion in document US 5,667,086 does not obviate this drawback, since the cap can be screwed back to a position in which

the edges of the cap and of the skirt match, thereby hiding the rupture of the breakable portion.

[0009] A closure that obviates the above drawbacks is described in WO 2013132384, by the Applicant hereof.

This closure with a tear-off seal causes the action of restoring the closure to its configuration prior to first opening to be overly complex and expensive for a counterfeiter. In detail, the closure comprises a cap adapted to close the mouth of the container, a capsule associated with the exterior of the cap and having fixing means for fixing the capsule to the container and tamper-evident means for providing evidence of first opening of the closure. The tamper-evident means comprise a first tear-off seal configured, when torn, to remove at least one portion of the capsule and a second tear-off seal for attaching the cap to the container and, when torn, allowing removal of the cap from the mouth of the container.

[0010] Alternative closures with tear-off seals have also been provided in the art, which at least partially obviate the above discussed drawbacks. Examples of such closures are disclosed in EP 3031743, EP 2897876 and EP 3397567. US 2016/167840 discloses a closure according to the preamble of claim 1.

Problem of the prior art

[0011] Nevertheless, the production of such closures is expensive and their assembly is complex and cost-ineffective.

[0012] In view of the above discussed prior art, the object of the present invention is to fulfill the above requirements, while obviating the prior art drawbacks.

Summary of the invention

[0013] According to the present invention, this object is fulfilled by a closure as defined in claim 1.

[0014] The present invention provides a closure with a tear-off seal that can be manufactured in comparatively easy and inexpensive manner, while still affording the advantages of the closures with tear-off seals of the prior art.

Brief description of the drawings

[0015] The characteristics and advantages of the present invention will appear from the following detailed description of one practical embodiment, which is illustrated without limitation in the annexed drawings, in which:

- Figure 1 shows a side view of a closure of a first embodiment of the present invention, in a first configuration,
- Figure 2 shows a cross-sectional view of the closure of Figure 1,
- Figure 3 shows a cross-sectional view of the closure of Figure 1,

- Figure 4 shows a side view of the closure of Figure 1, in a second configuration,
- Figure 5 shows a side view of the closure of Figure 1, in a third configuration,
- Figure 6 shows a side view of a closure of a second embodiment of the present invention, in a first configuration,
- Figure 7 shows a cross-sectional view of the closure of Figure 6,
- Figure 8 shows a side view of the closure of Figure 6, in a second configuration,
- Figure 9 shows a side view of the closure of Figure 6, between the second configuration and a third configuration,
- Figure 10 shows a side view of the closure of Figure 6, in a third configuration,
- Figure 11 shows a side view of a closure of a third embodiment of the present invention, in a first configuration,
- Figure 12 shows a side view of the closure of Figure 11, in a second configuration,
- Figure 13 shows a side view of the closure of Figure 11, in a third configuration,
- Figure 14 shows a side view of a closure of a fourth embodiment of the present invention, in a first configuration,
- Figure 15 shows a cross-sectional view of the closure of Figure 14,
- Figure 16 shows a top view of the closure of Figure 14,
- Figure 17 shows a side view of the closure of Figure 14, in a second configuration,
- Figure 18 shows a side view of the closure of Figure 14, in a third configuration,
- Figure 19 shows a side view of the closure of Figure 14, in a fourth configuration.

Detailed description

[0016] Even when not expressly stated, the individual features as described with reference to the particular embodiments shall be intended as auxiliary to and/or interchangeable with other features described with reference to other exemplary embodiments.

[0017] Referring to the accompanying drawings, the present invention relates to a closure 1.

[0018] The closure 1 is intended to close the mouth of a container 2, e.g. a bottle, such as a glass bottle, e.g. for spirits.

[0019] In the example of the figures, the container 2 is a bottle and comprises a neck 4 that terminates in a mouth 3 defining a pouring orifice 3a.

[0020] While the closure 1 in itself may be oriented in any direction, for the purposes of the present direction the vertical axis will be defined as the longitudinal axis X-X of the closure 1 and conventionally the bottom side is the side of the closure 1 designed to face towards the container 2, and the top side is the one designed to face

towards the consumer; this is actually the normal orientation of the closure when fitted onto a normally oriented bottle (as shown in the figures).

[0021] According to one embodiment, not forming part of the invention, a pouring body (not shown) can be coupled to the closure 1 to form a closure assembly and can be applied to the neck 4 of the container 2 and fixed thereto by known fixing means adapted to prevent relative rotational and longitudinal movements of the pouring body with respect to the neck 4 of the container 2. The pouring body has a pouring orifice which defines the pouring orifice of the container 2.

[0022] Reference will be made below without limitation to a closure 1 for closing the mouth 3 of the container 2.

[0023] The closure 1 comprises a cap 10 for closing the mouth 3 of the container 2, namely for closing the pouring orifice 3a of the mouth 3.

[0024] According to an embodiment, the cap 10 comprises a sleeve 11 open at its bottom and closed at its top by a the top wall 12.

[0025] Namely, the sleeve 11 extends in a longitudinal direction X-X between a lower edge 13, at which the sleeve 11 is open, and an upper end 14, having the top wall 12 thereat.

[0026] The cap 10 has an outer surface 11a and an inner surface 11b, consisting of the outer and inner surfaces of the sleeve 11 respectively. The outer surface 11a is the part of the cap 10 that can be grasped by a user to open and close the mouth 3 of the container 2.

[0027] The cap 10 comprises attachment members 15 for reversibly attaching the cap 10 to the mouth 3 of the container 2. This affords normal opening and closing operations to be performed on the mouth 3 of the container 2.

[0028] Preferably, the attachment members 15 comprise a thread formed on the inner surface 11b of the cap 10 and designed to be engaged with a thread 4a associated with the container 2 and, for example, formed on the outer surface of the mouth 3 or on the outer surface of a pouring body.

[0029] Alternatively, the attachment members may comprise snap-on members for flip-top caps.

[0030] The closure 1 comprises a tubular element 20 configured to surround the neck 4 of the container 2.

[0031] The closure 1 is equipped with fixing members 21 for fixing the tubular element 20 to the neck 4 of the container 2.

[0032] According to one embodiment, the fixing members 21 comprise first fixing members 22 for preventing longitudinal displacements of the tubular element 20 relative to the container 2 and second fixing members 23 for preventing angular displacements of the tubular element 20 relative to the container 2.

[0033] In this example, the first fixing members 22 comprise an annular ridge 22a formed on the interior of the tubular element 20, and designed for snap engagement of a collar 6 formed on the neck 4 of the container 2 and the second fixing members 23 comprise axial ribs 23a

arranged on the interior of the tubular element 20 and designed to engage corresponding grooves 7 on the neck 4 of the container 2.

[0034] According to an alternative embodiment, the fixing members 21 act on elements fixed to the container 2 and arranged between the tubular element 20 and the container 2. For example, the fixing members 21 can fix the tubular element 20 to a pouring body which, in turn, is intended to be stably fixed to the neck 4 of the container 2.

[0035] The closure 1 further comprises tamper-evident members for providing evidence of first opening of the closure 1.

[0036] The tamper-evident members comprise a first tear-off seal 40 and a second tear-off seal 30.

[0037] The first tear-off seal 40 is attached to the second tear-off seal 30 and is configured, when torn, to allow the second tear-off seal 30 to be torn.

[0038] The second tear-off seal 30 is attached to the cap 10 and to the tubular element 20 and is configured, when torn, to allow the cap 10 to be removed from the container 2.

[0039] The cap 10, the tubular element 20, the first tear-off seal 40 and the second tear-off seal 30 define a unitary body, formed of one piece. This configuration allows the closure 1 to be manufactured in a cost-effective manner, by eliminating the assembly steps. Also, this configuration can provide a closure that can be entirely removed from the neck 4 of the container and is therefore separable from the container.

[0040] In one embodiment, the one-piece unitary body is made of a compostable biodegradable material. In this case, the closure 1 is both easily separable from the container, for example made of glass, and is disposable as normal organic waste.

[0041] The first tear-off seal 40 comprises a first tear-off tab 44 configured to be grasped to tear off the first tear-off seal 40.

[0042] The first tear-off tab 44 has a grip portion 44a which is adapted to be grasped to tear off the first tear-off tab 44.

[0043] The second tear-off seal 30 comprises a second tear-off tab 31 configured to be grasped to tear off the second tear-off seal 30.

[0044] The second tear-off tab 31 has a grip portion 31a adapted to be grasped to tear off the second pull-tab 31.

[0045] Preferably, the first tear-off seal 40 is arranged to prevent the second tear-off seal 30 from being grasped prior to removal of the first tear-off seal 40 and to allow the second tear-off seal 30 to be grasped upon removal of the first tear-off seal 40.

[0046] In the first, second and third embodiments of Figures 1 to 13, at least a part of the first tear-off seal 40 extends radially outwards beyond the radial extent of second tear-off tab 31.

[0047] In the fourth embodiment of Figures 14 to 19, at least a part of the first tear-off seal 40 surrounds the

cap 10 and at least partially the second tear-off seal 30, and namely surrounds at least the second tear-off tab 31.

[0048] Thus, in all the embodiments, the second tear-off seal 30 can only be torn after tearing and then removing the first tear-off seal 40. This is because the first seal 40 prevents access to the tab 31 of the second seal 30.

[0049] In the embodiments of Figures 1-13, the second tear-off tab 31 cannot be accessed by the user since it is arranged radially inside a part of the first tear-off seal 40 which prevents the grip portion 31a from being grasped.

[0050] In the fourth embodiment of Figures 14-19, possibly also in combination with the embodiments of Figures 1-13, the second tear-off tab 31 cannot be accessed by the user because it is covered by a part of the first tear-off seal 40.

[0051] In particular, the closure 1 is adapted to irreversibly move from a first configuration, before tearing of the first seal 40 to a second configuration, after tearing of the first seal 40.

[0052] Therefore, the first seal 40 is configured to prevent tearing of the second seal 30 when the closure 1 is in the first configuration and to only allow tearing of the second seal 30 when the closure 1 is in the second configuration.

[0053] When the closure 1 is in the second configuration, the second seal 30 may be torn to move the closure to a third configuration.

[0054] According to one embodiment, the second tear-off seal 30 comprises a circumferential band 32 joined to the second tab 31.

[0055] The circumferential band 32 of the second tear-off seal 32 is attached to the first tear-off seal 40 and to the tubular element 20 via respective breakable portions 33a, 33b. The breakable portions 33a that attach the circumferential band 32 to the first tear-off seal 40 are configured to break upon tearing of the first tear-off seal 40, whereas the breakable portions 33b that attach the circumferential band 32 to the tubular element 20 are configured to break upon tearing of the second tear-off seal 30. Alternatively, the circumferential band 32 is a peelable tear-off band, which is still connected to the first tear-off seal 40 and to the tubular element 20.

[0056] In the first embodiments of Figures 6 to 19, the tubular element 20 comprises a longitudinal tear-off band 24 which is configured, when torn, to allow removal of the tubular element 20. The longitudinal tear-off band 24 extends in the longitudinal direction X-X.

[0057] In the embodiment of Figures 6 to 10, the longitudinal tear-off band 24 is connected to the second tear-off seal 30. More preferably, the longitudinal tear-off band 24 is connected to the circumferential band 32 to define a single tear-off band of the second tear-off seal 30. In this embodiment, removal of the second tear-off seal 30 also causes removal of the tubular element 20. In this embodiment, tearing of the longitudinal band 24 can occur in two different modes. In a first mode, a lower portion of the longitudinal band 24 remains attached to a lower

end 27 of the tubular element 20 so that the user can also remove with a single tear the tubular element 20 of the neck 4. In a second mode, the longitudinal band 24 is removable and separable entirely from the tubular element 20 so that, once the longitudinal band 24 has been removed, the tubular element 20 will have a C shape with facing longitudinal edges and can be removed by the user when desired.

[0058] In the embodiments of Figures 11 to 19, the longitudinal tear-off band 24 is separated from the second tear-off seal 30. In these embodiments, when the closure 1 is in the third configuration, the longitudinal tear-off band 24 can be torn to also remove the tubular element 20 according to one of the two modes as described above.

[0059] In one embodiment, the longitudinal band 24 comprises two longitudinal weakness lines 25a, 25b which are adapted to break upon tearing of the longitudinal band 24.

[0060] The longitudinal weakness lines 25a, 25b extend in the longitudinally direction X-X- from an upper end 26 of the tubular element 20 along at least a section of the tubular element 20.

[0061] Preferably, the longitudinal weakness lines 25a, 25b extend in the longitudinal direction X-X from the upper end 26 of the tubular element 20 along the entire longitudinal extent of the tubular element 20 to its lower end 27.

[0062] The first tear-off seal 40 comprises an annular element 41 which surrounds the cap 10 and extends in the longitudinal direction X-X between a lower end portion 42 and an upper end portion 43.

[0063] The cap 10, in particular its lower edge 13, is attached to the circumferential band 32 of the second tear-off seal 30 by breakable portions 45. Therefore, as the second tear-off seal 30 is torn, it causes the breakable portions 45 to break, thereby releasing the attachment between the second tear-off seal 30 and the cap 10, which can be thus removed by the user.

[0064] Preferably, the attachment between the first tear-off seal 40 and the second tear-off seal 30, formed by the breakable portions 33a, is weaker than the attachment between the second tear-off seal 30 and the cap 10, formed by the breakable portions 45. This will prevent tearing of the first tear-off seal 40 from causing the release of the second tear-off seal 30 from the cap 10.

[0065] According to one embodiment, the first tear-off seal 40 is open at its top, level with the top wall 12 of the cap 10.

[0066] In particular, the upper end portion 43 defines the upper opening of the first tear-off seal 40 and delimits the top wall 12 of the cap 10.

[0067] Therefore, the closure 1 of the present invention fulfills the intended purposes.

[0068] Those skilled in the art will obviously appreciate that a number of changes and variants may be made to the arrangements as described hereinbefore to meet incidental and specific needs.

[0069] For example, unless otherwise imposed by evident technical limitations, any feature described in a preferred embodiment may be clearly used in another embodiment, with appropriate adaptations.

[0070] Likewise, the continuity of the closure components may be broken in any manner, provided that no functional alteration to the relevant component is caused thereby.

[0071] Also, slight tapers may be imparted to the portions described above as having an annular or tubular shape, in response to technological requirements.

[0072] All the changes will fall within the scope of the invention, as defined in the following claims.

Claims

1. A closure (1) for a container (2) having a neck (4) ending with a pouring orifice (3a), comprising:

- a cap (10) configured to close the pouring orifice, the cap (10) comprising a top wall (12) and a sleeve (11) extending from the top wall to a bottom edge (13),
- a tubular element (20) configured to surround at least a section of the neck (4) of the container,
- a first tear-off seal (40) and a second tear-off seal (30);

wherein:

- the first tear-off seal (40) is configured, when torn, to allow the second tear-off seal (30) to be torn,
- the second tear-off seal (30) is attached to the cap (10) and to the tubular element (20) and is configured, when torn, to allow the cap (10) to be removed from the container,

characterized in that:

- the first tear-off seal (40) is attached to the second tear-off seal (30), and
- the cap (10), the tubular element (20), the first tear-off seal (40) and the second tear-off seal (30) define a unitary body.

2. A closure (1) as claimed in claim 1, wherein:

- the first tear-off seal (40) comprises a first tear-off tab (44) configured to be grasped to tear off the first tear-off seal (40),
- the second tear-off seal (30) comprises a second tear-off tab (31) configured to be grasped to tear off the second tear-off seal (30),
- the first tear-off seal (40) is arranged to prevent the second tab (31) of the second tear-off seal (30) from being grasped prior to removal of the

- first tear-off seal (40) and to allow the second tab (31) of the second tear-off seal (30) to be grasped upon removal of the first tear-off seal (40).
- 3.** A closure (1) as claimed in claim 2, wherein
- the second tear-off seal (30) comprises a circumferential band (32) joined to the second tab (31),
 - the circumferential band (32) is attached to the first tear-off seal (40) and to the tubular element (20) via respective breakable portions (33a, 33b),
 - the breakable portions (33a) that attach the circumferential band (32) to the first tear-off seal (40) are configured to break upon tearing of the first tear-off seal (40),
 - the breakable portions (33b) that attach the circumferential band (32) to the tubular element (20) are configured to break upon tearing of the second tear-off seal (30).
- 4.** A closure (1) as claimed in claim 3, wherein:
- the cap (10) is attached to the circumferential band (32) by breakable portions (45) which are configured to break upon tearing of the second tear-off seal (30) to release the attachment between the second tear-off seal (30) and the cap (10) and to enable removal of the cap (10).
- 5.** A closure (1) as claimed in any of claims 1 to 4, wherein:
- the tubular element (20) comprises a longitudinal tear-off band (24) which is configured, when torn, to allow removal of the tubular element (20).
- 6.** A closure (1) as claimed in claim 5, wherein:
- the longitudinal tear-off band (24) is connected to second tear-off seal (30).
- 7.** A closure as claimed in claims 5 and 6, wherein the longitudinal tear-off band (24) is connected to the circumferential band (32) to define a single tear-off band.
- 8.** A closure (1) as claimed in any of claims 5 to 7, wherein:
- the longitudinal tear-off band (24) comprises two longitudinal weakness lines (25a, 25b) which are adapted to break upon tearing of the longitudinal tear-off band (24),
 - the longitudinal weakness lines (25a, 25b) longitudinally extending from an upper end (26) of the tubular element (20) along at least a section of the tubular element (20).
- 9.** A closure (1) as claimed in any of claims 1 to 8, wherein:
- the first tear-off seal (40) is open at its top, level with the top wall (12) of the cap (10).
- 10.** A closure (1) as claimed in claim 9, wherein:
- the first tear-off seal (40) comprises an annular element (41) extending between a lower end portion (42) and an upper end portion (43),
 - the upper end portion (43) of the annular element (41) of the first seal (40) defines the upper opening of the first tear-off seal (40) and delimits the top wall (12) of the cap (10).
- 11.** A closure (1) as claimed in any of claims 1 to 10, wherein:
- the closure (1) is adapted to irreversibly move from a first configuration, before tearing of the first seal (40) to a second configuration, after tearing of the first seal (40),
 - the first seal (40) is configured to prevent tearing of the second tear-off seal (30) when the closure is in the first configuration and to allow tearing of the first tear-off seal (30) only when the closure (1) is in the second configuration.
- 12.** A closure (1) as claimed in any of claims 2 to 11, wherein:
- at least a part of the first tear-off seal (40) surrounds at least the second tear-off tab (31).
- 13.** A closure (1) as claimed in any of claims 2 to 11, wherein:
- at least a part of the first tear-off seal (40) extends radially outwards beyond the radial extent of second tear-off tab (31).
- 14.** A closure (1) as claimed in any of claims 1 to 13, wherein the unitary body is formed of one piece.
- 15.** A closure (1) according to any of claims 1 to 14, wherein the unitary body is made of one piece composed of biodegradable compostable material.
- Patentansprüche**
- 1.** Verschluss (1) für einen Behälter (2) aufweisend einen Hals (4), der mit einer Eingießöffnung (3a) en-

det, umfassend:

- eine Kappe (10), die konfiguriert ist, die Eingießöffnung zu verschließen, wobei die Kappe (10) eine Oberwand (12) und eine Hülse (11) umfasst, die sich von der Oberwand zu einem unteren Rand (13) erstreckt,
- ein Rohrelement (20), das konfiguriert ist, mindestens einen Abschnitt des Halses (4) des Behälters umzugeben,
- eine erste Abreißversiegelung (40) und eine zweite Abreißversiegelung (30);

wobei:

- die erste Abreißversiegelung (40) konfiguriert ist, beim Abreißen, das Abreißen der zweiten Abreißversiegelung (30) zu ermöglichen,
- die zweite Abreißversiegelung (30) an der Kappe (10) und an dem Rohrelement (20) befestigt ist und konfiguriert ist, beim Abreißen, das Entfernen der Kappe (10) vom Behälter zu ermöglichen,

dadurch gekennzeichnet, dass:

- die erste Abreißversiegelung (40) an der zweiten Abreißversiegelung (30) befestigt ist, und
- die Kappe (10), das Rohrelement (20), die erste Abreißversiegelung (40) und die zweite Abreißversiegelung (30) einen einheitlichen Körper bilden.

2. Verschluss (1) nach Anspruch 1, wobei:

- die erste Abreißversiegelung (40) eine erste Abreißlasche (44) umfasst, die konfiguriert ist, zum Abreißen der ersten Abreißversiegelung (40) ergriffen zu werden,
- die zweite Abreißversiegelung (30) eine zweite Abreißlasche (31) umfasst, die konfiguriert ist, zum Abreißen der zweiten Abreißversiegelung (30) ergriffen zu werden,
- die erste Abreißversiegelung (40) eingerichtet ist, zu verhindern, dass die zweite Lasche (31) der zweiten Abreißversiegelung (30) vor dem Entfernen der ersten Abreißversiegelung (40) ergriffen wird, und zu ermöglichen, dass die zweite Lasche (31) der zweiten Abreißversiegelung (30) nach dem Entfernen der ersten Abreißversiegelung (40) ergriffen wird.

3. Verschluss (1) nach Anspruch 2, wobei

- die zweite Abreißversiegelung (30) ein Umfangsband (32) umfasst, das mit der zweiten Lasche (31) verbunden ist,
- das Umfangsband (32) an der ersten

Abreißversiegelung (40) und an dem Rohrelement (20) über entsprechende abbrechbare Abschnitte (33a, 33b) befestigt ist,

- die abbrechbaren Abschnitte (33a), die das Umfangsband (32) an der ersten Abreißversiegelung (40) befestigen, konfiguriert sind, sich beim Abreißen der ersten Abreißversiegelung (40) zu brechen,

- die abbrechbaren Abschnitte (33b), die das Umfangsband (32) an dem Rohrelement (20) befestigen, konfiguriert sind, sich beim Abreißen der zweiten Abreißversiegelung (30) zu brechen.

4. Verschluss (1) nach Anspruch 3, wobei:

- die Kappe (10) an dem Umfangsband (32) mittels abbrechbarer Abschnitte (45) befestigt ist, die konfiguriert sind, sich beim Abreißen der zweiten Abreißversiegelung (30) zu brechen, um die Befestigung zwischen der zweiten Abreißversiegelung (30) und der Kappe (10) zu lösen und das Entfernen der Kappe (10) zu ermöglichen.

5. Verschluss (1) nach einem der Ansprüche 1 bis 4, wobei:

- das Rohrelement (20) ein Längsabreißband (24) umfasst, das konfiguriert ist, beim Abreißen das Entfernen des Rohrelements (20) zu ermöglichen.

6. Verschluss (1) nach Anspruch 5, wobei:

- das Längsabreißband (24) mit der zweiten Abreißversiegelung (30) verbunden ist.

7. Verschluss nach einem der Ansprüche 5 und 6, wobei das Längsabreißband (24) mit dem Umfangsband (32) verbunden ist, um ein einziges Abreißband zu bilden.

8. Verschluss (1) nach einem der Ansprüche 5 bis 7, wobei:

- das Längsabreißband (24) zwei Längsschwächungslinien (25a, 25b) umfasst, die eingerichtet sind, sich beim Abreißen des Längsabreißbandes (24) zu brechen,

- die Längsschwächungslinien (25a, 25b) sich in Längsrichtung von einem oberen Ende (26) des Rohrelements (20) entlang mindestens eines Abschnitts des Rohrelements (20) erstrecken.

9. Verschluss (1) nach einem der Ansprüche 1 bis 8, wobei:

- die erste Abreißversiegelung (40) an ihrer Oberseite, in Höhe der Oberwand (12) der Kappe (10) offen ist.
- 10.** Verschluss (1) nach Anspruch 9, wobei:
- die erste Abreißversiegelung (40) ein ringförmiges Element (41) umfasst, das sich zwischen einem unteren Endabschnitt (42) und einem oberen Endabschnitt (43) erstreckt,
 - der obere Endabschnitt (43) des ringförmigen Elements (41) der ersten Versiegelung (40) die obere Öffnung der ersten Abreißversiegelung (40) definiert und die Oberwand (12) der Kappe (10) begrenzt.
- 11.** Verschluss (1) nach einem der Ansprüche 1 bis 10, wobei:
- der Verschluss (1) eingerichtet ist, sich irreversibel von einer ersten Konfiguration vor dem Abreißen der ersten Versiegelung (40) in eine zweite Konfiguration nach dem Abreißen der ersten Versiegelung (40) zu bewegen,
 - die erste Versiegelung (40) konfiguriert ist, das Abreißen der zweiten Abreißversiegelung (30) zu verhindern, wenn sich der Verschluss in der ersten Konfiguration befindet, und das Abreißen der ersten Abreißversiegelung (30) zu ermöglichen, nur wenn sich der Verschluss (1) in der zweiten Konfiguration befindet.
- 12.** Verschluss (1) nach einem der Ansprüche 2 bis 11, wobei:
- mindestens ein Teil der ersten Abreißversiegelung (40) mindestens die zweite Abreißlasche (31) umgibt.
- 13.** Verschluss (1) nach einem der Ansprüche 2 bis 11, wobei:
- mindestens ein Teil der ersten Abreißversiegelung (40) radial nach außen über die radiale Ausdehnung der zweiten Abreißlasche (31) vorsteht.
- 14.** Verschluss (1) nach einem der Ansprüche 1 bis 13, wobei der einheitliche Körper aus einem Stück besteht.
- 15.** Verschluss (1) nach einem der Ansprüche 1 bis 14, wobei der einheitliche Körper aus einem Stück besteht, das aus biologisch abbaubarem kompostierbarem Material besteht.

Revendications

- 1.** Fermeture (1) pour un récipient (2) ayant un col (4) se terminant par un orifice de versement (3a), comprenant :

- un bouchon (10) configuré pour fermer l'orifice de versement, le bouchon (10) comprenant une paroi de dessus (12) et un manchon (11) s'étendant de la paroi de dessus à un bord de dessous (13),
- un élément tubulaire (20) configuré pour entourer au moins une section du col (4) du récipient,
- un premier opercule à déchirer (40) et un second opercule à déchirer (30) ;

dans laquelle :

- le premier opercule à déchirer (40) est configuré, lorsqu'il est déchiré, pour permettre au second opercule à déchirer (30) d'être déchiré,
- le second opercule à déchirer (30) est fixé au bouchon (10) et à l'élément tubulaire (20) et est configuré, lorsqu'il est déchiré, pour permettre au bouchon (10) d'être retiré du récipient,

caractérisée en ce que :

- le premier opercule à déchirer (40) est fixé au second opercule à déchirer (30), et
- le bouchon (10), l'élément tubulaire (20), le premier opercule à déchirer (40) et le second opercule à déchirer (30) forment un corps unitaire.

- 2.** Fermeture (1) selon la revendication 1, dans laquelle :

- le premier opercule à déchirer (40) comprend une première languette à déchirer (44) configurée pour être saisie afin de déchirer le premier opercule à déchirer (40),
- le second opercule à déchirer (30) comprend une seconde languette à déchirer (31) configurée pour être saisie afin de déchirer le second opercule à déchirer (30),
- le premier opercule à déchirer (40) est agencé pour empêcher la deuxième languette (31) du deuxième opercule à déchirer (30) d'être saisie avant le retrait du premier opercule à déchirer (40) et pour permettre à la deuxième languette (31) du deuxième opercule à déchirer (30) d'être saisie après le retrait du premier opercule à déchirer (40).

- 3.** Fermeture (1) selon la revendication 2, dans laquelle

- le second opercule à déchirer (30) comprend

- une bande circonférentielle (32) jointe à la seconde languette (31),
 - la bande circonférentielle (32) est fixée au premier opercule à déchirer (40) et à l'élément tubulaire (20) par des portions cassables respectives (33a, 33b),
 - les portions cassables (33a) qui fixent la bande circonférentielle (32) au premier opercule à déchirer (40) sont configurées pour se casser après déchirure du premier opercule à déchirer (40),
 - les portions cassables (33b) qui fixent la bande circonférentielle (32) à l'élément tubulaire (20) sont configurées pour se casser après déchirure du second opercule à déchirer (30).
4. Fermeture (1) selon la revendication 3, dans laquelle :
- le bouchon (10) est fixé à la bande circonférentielle (32) par des portions cassables (45) qui sont configurées pour se casser lors de la déchirure du second opercule à déchirer (30) afin de libérer la fixation entre le second opercule à déchirer (30) et le bouchon (10) et d'autoriser le retrait du bouchon (10).
5. Fermeture (1) selon l'une quelconque des revendications 1 à 4, dans laquelle :
- l'élément tubulaire (20) comprend une bande à déchirer longitudinale (24) qui est configurée, lorsqu'elle est déchirée, pour permettre le retrait de l'élément tubulaire (20).
6. Fermeture (1) selon la revendication 5, dans laquelle :
- la bande à déchirer longitudinale (24) est reliée au deuxième opercule à déchirer (30).
7. Fermeture selon les revendications 5 et 6, dans laquelle la bande à déchirer longitudinale (24) est reliée à la bande circonférentielle (32) pour former une seule bande à déchirer.
8. Fermeture (1) selon l'une quelconque des revendications 5 à 7, dans laquelle :
- la bande à déchirer longitudinale (24) comprend deux lignes de faiblesse longitudinales (25a, 25b) qui sont destinées à se casser lors du déchirement de la bande à déchirer longitudinale (24),
 - les lignes de faiblesse longitudinales (25a, 25b) s'étendent longitudinalement à partir d'une extrémité supérieure (26) de l'élément tubulaire (20) le long d'au moins une section de l'élément tubulaire (20).
9. Fermeture (1) selon l'une quelconque des revendications 1 à 8, dans laquelle :
- le premier opercule à déchirer (40) est ouvert au niveau de son dessus, au niveau de la paroi de dessus (12) du bouchon (10).
10. Fermeture (1) selon la revendication 9, dans laquelle :
- le premier opercule à déchirer (40) comprend un élément annulaire (41) qui s'étend entre une portion d'extrémité inférieure (42) et une portion d'extrémité supérieure (43),
 - la portion d'extrémité supérieure (43) de l'élément annulaire (41) du premier opercule (40) définit l'ouverture supérieure du premier opercule à déchirer (40) et délimite la paroi de dessus (12) du bouchon (10).
11. Fermeture (1) selon l'une quelconque des revendications 1 à 10, dans laquelle :
- la fermeture (1) est conçue pour passer irréversiblement d'une première configuration, avant la déchirure du premier opercule (40) à une seconde configuration, après la déchirure du premier opercule (40),
 - le premier opercule (40) est configuré pour empêcher la déchirure du second opercule à déchirer (30) lorsque la fermeture est dans la première configuration et pour permettre la déchirure du premier opercule à déchirer (30) uniquement lorsque la fermeture (1) est dans la seconde configuration.
12. Fermeture (1) selon l'une quelconque des revendications 2 à 11, dans laquelle :
- au moins une partie du premier opercule à déchirer (40) entoure au moins la deuxième languette à déchirer (31).
13. Fermeture (1) selon l'une quelconque des revendications 2 à 11, dans laquelle :
- au moins une partie du premier opercule à déchirer (40) s'étend radialement vers l'extérieur au-delà de l'étendue radiale de la deuxième languette à déchirer (31).
14. Fermeture (1) selon l'une des revendications 1 à 13, dans laquelle le corps unitaire est formé d'une seule pièce.
15. Fermeture (1) selon l'une des revendications 1 à 14,

dans laquelle le corps unitaire est constitué d'une seule pièce composée d'un matériau biodégradable et compostable.

5

10

15

20

25

30

35

40

45

50

55

10

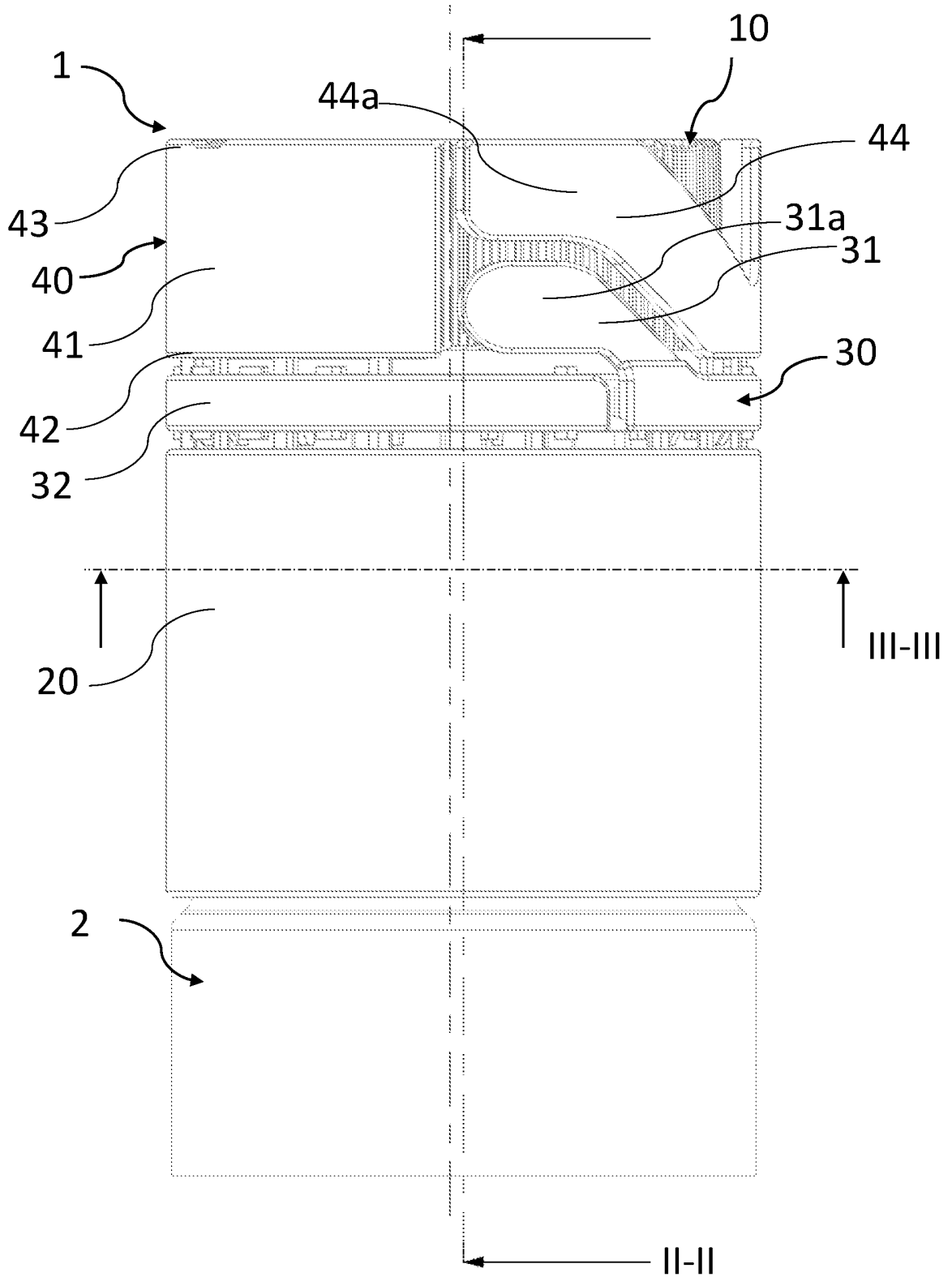

Fig. 1

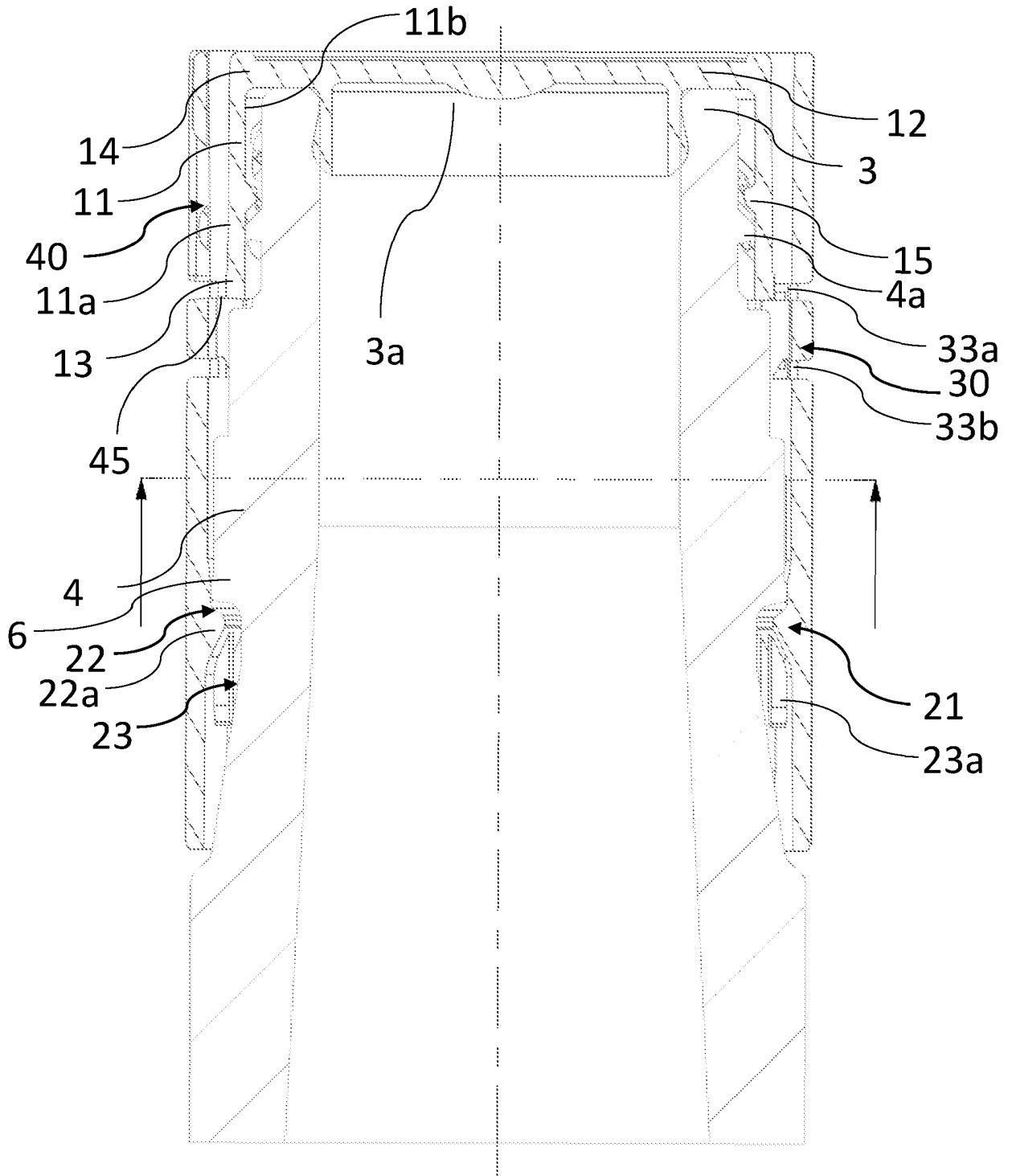

Fig. 2

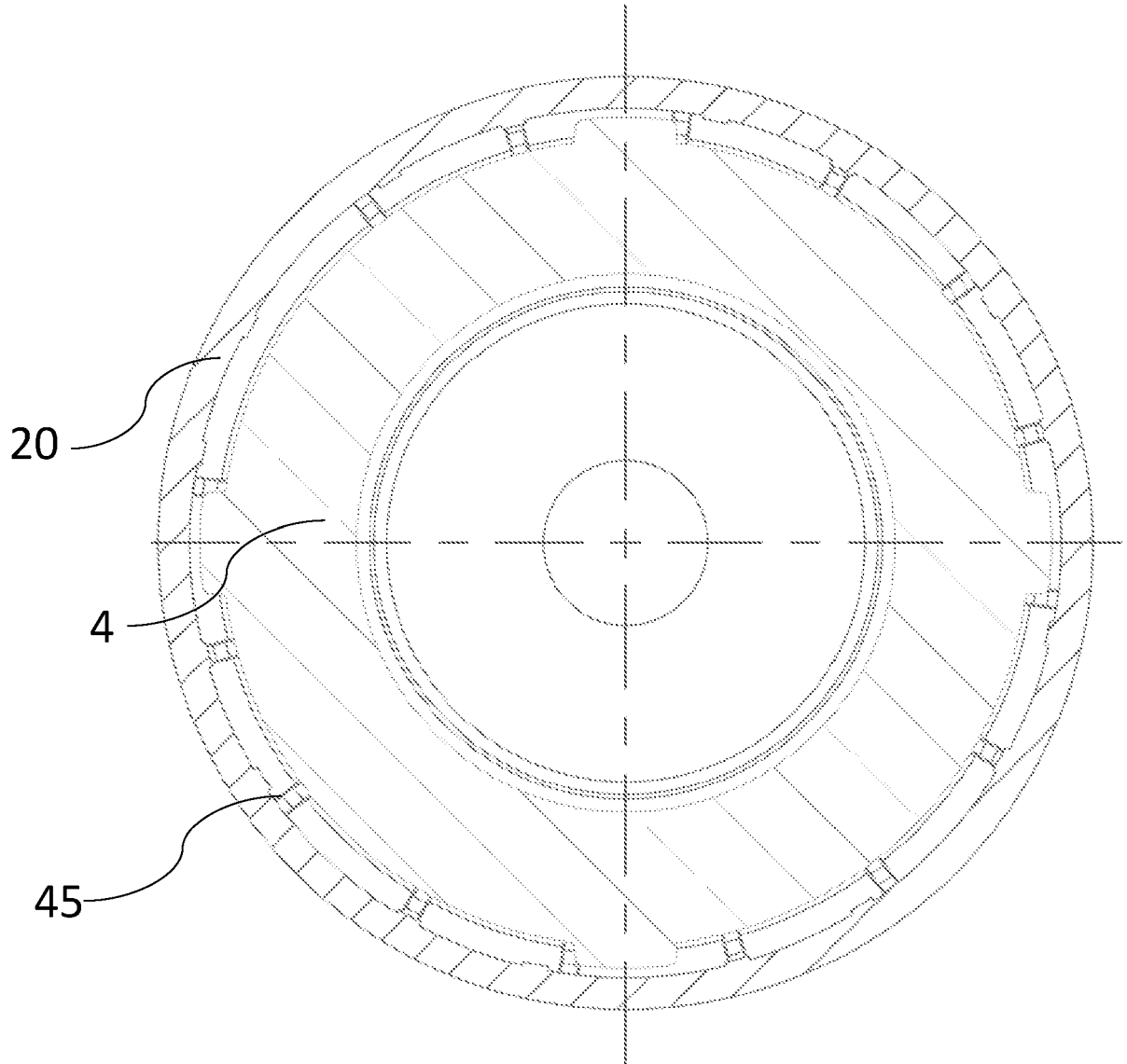

Fig. 3

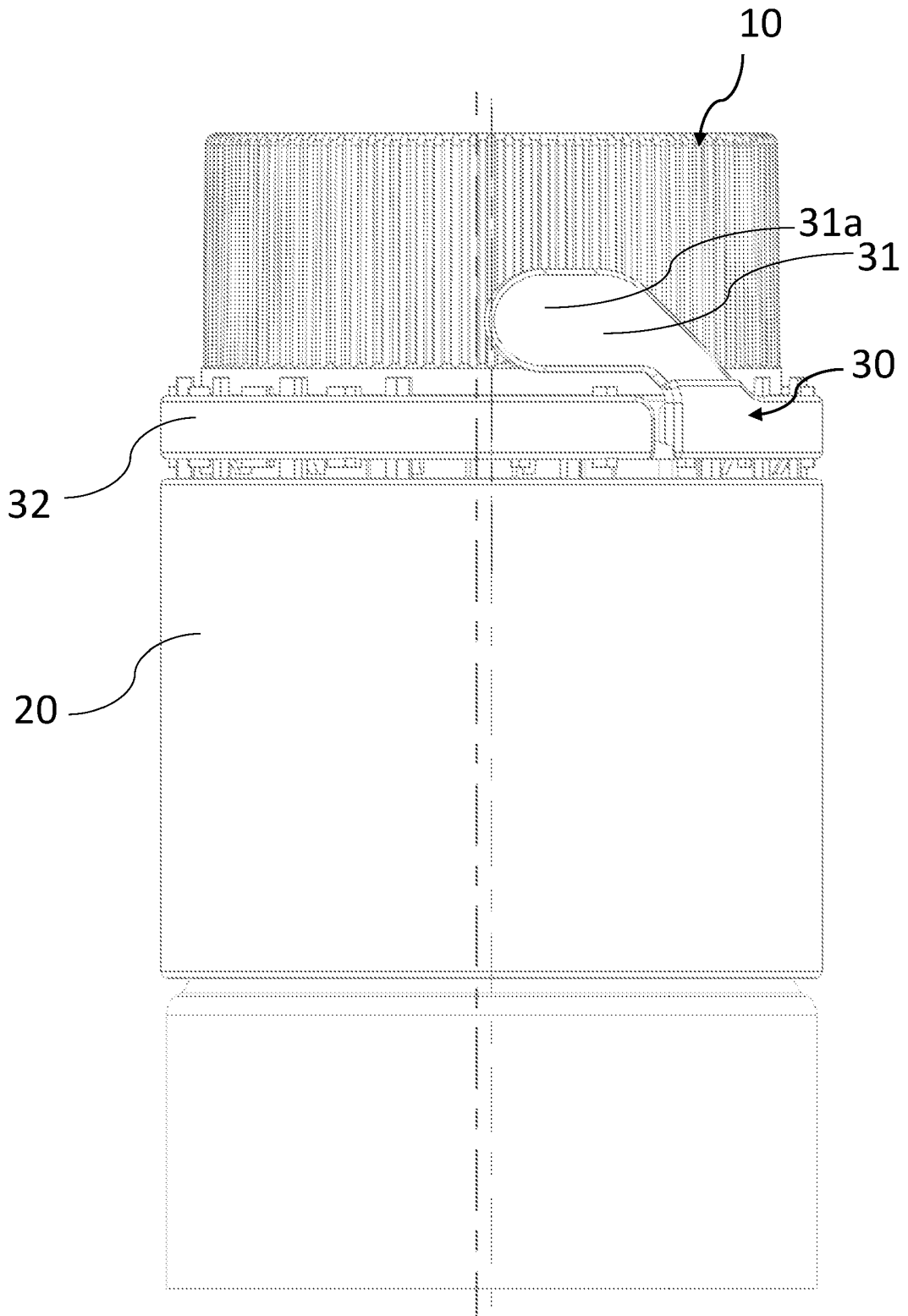

Fig. 4

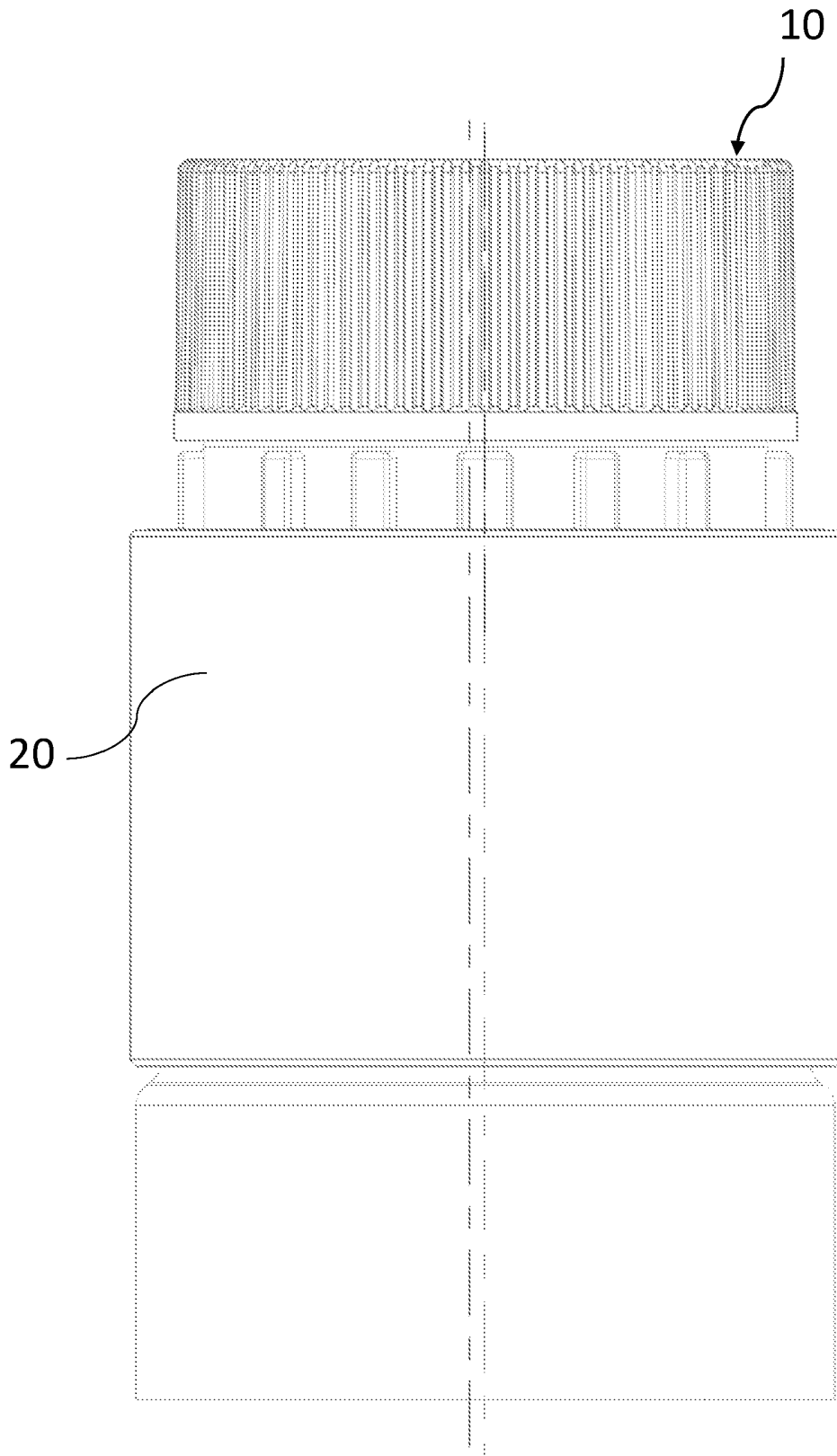

Fig. 5

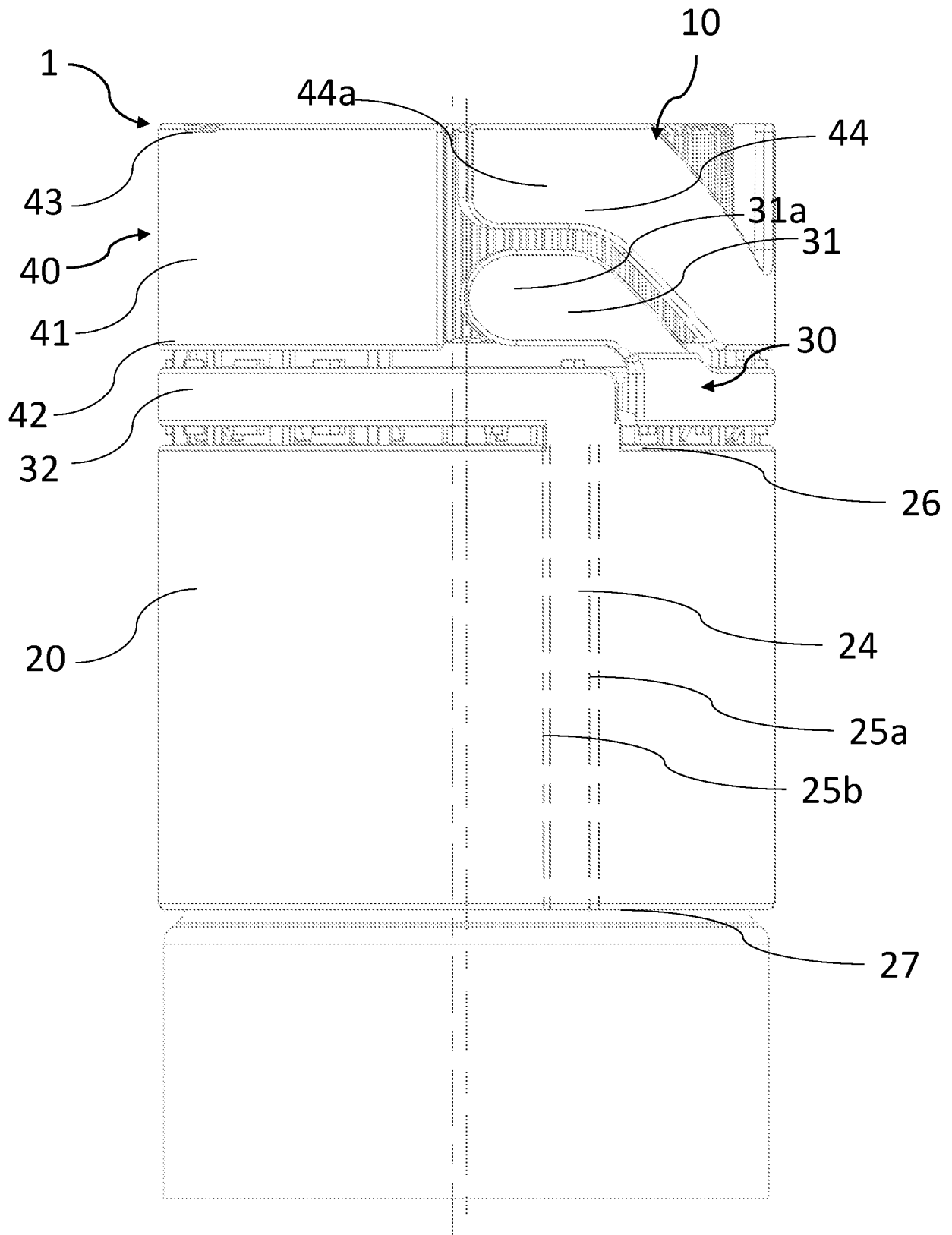

Fig. 6

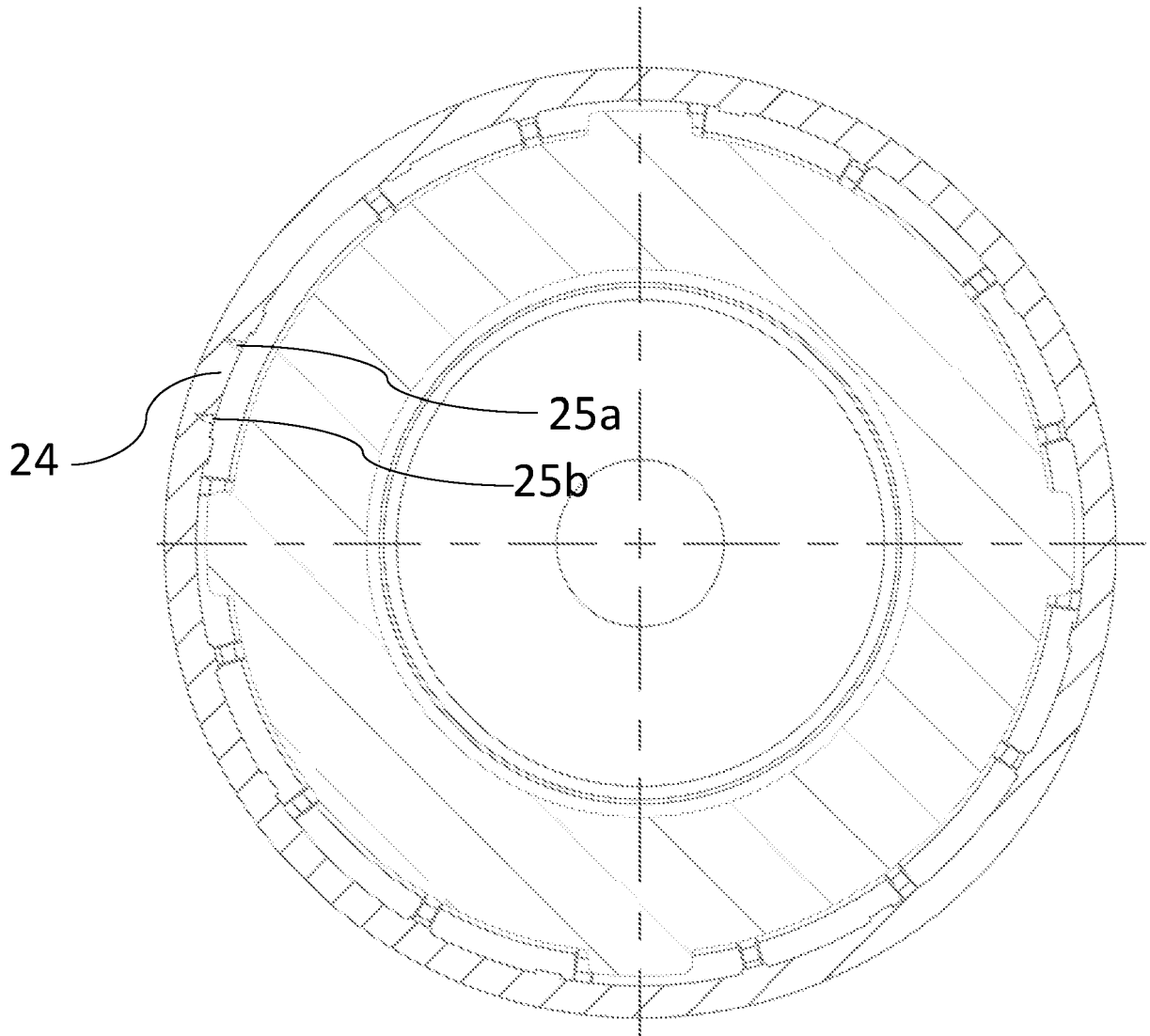

Fig. 7

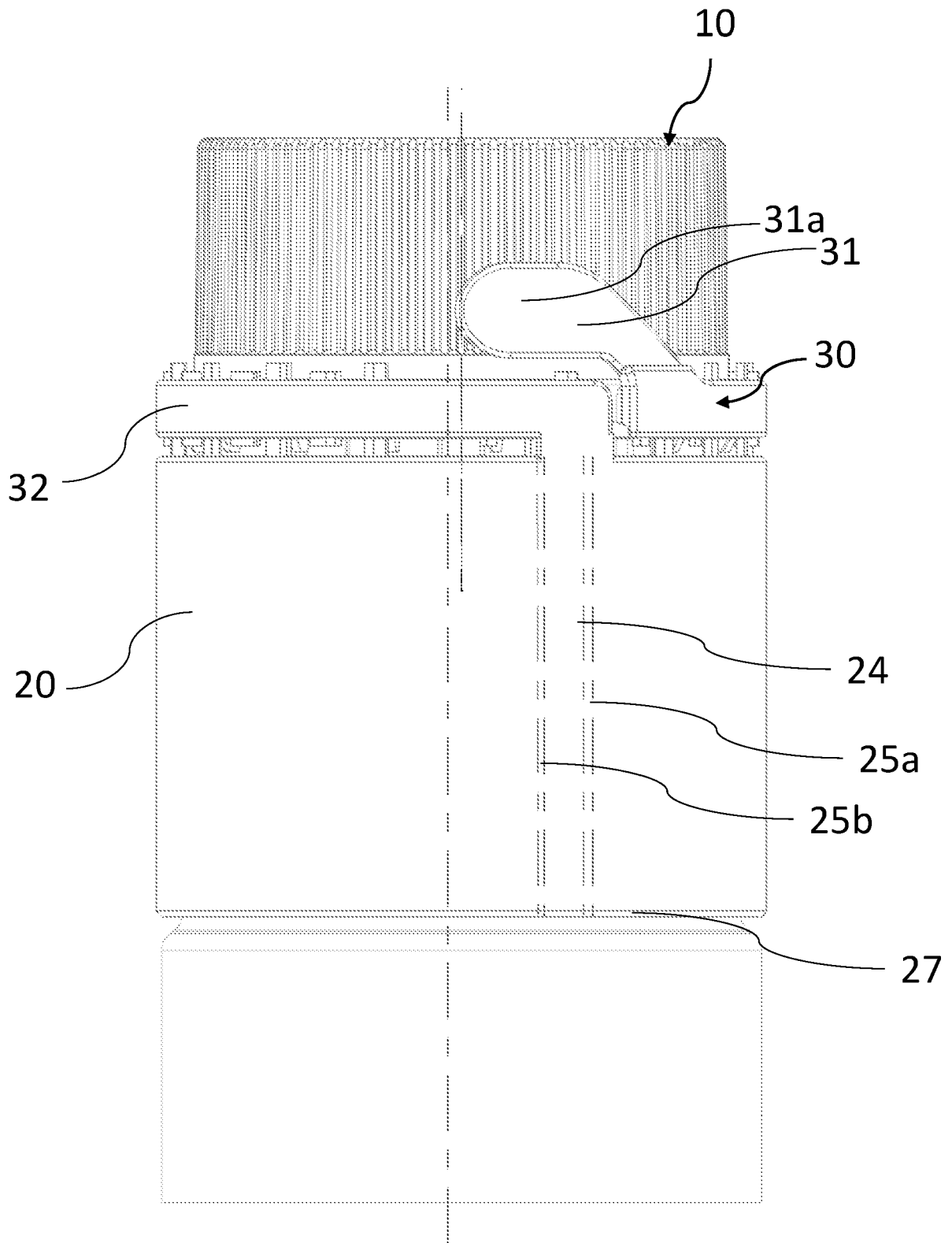

Fig. 8

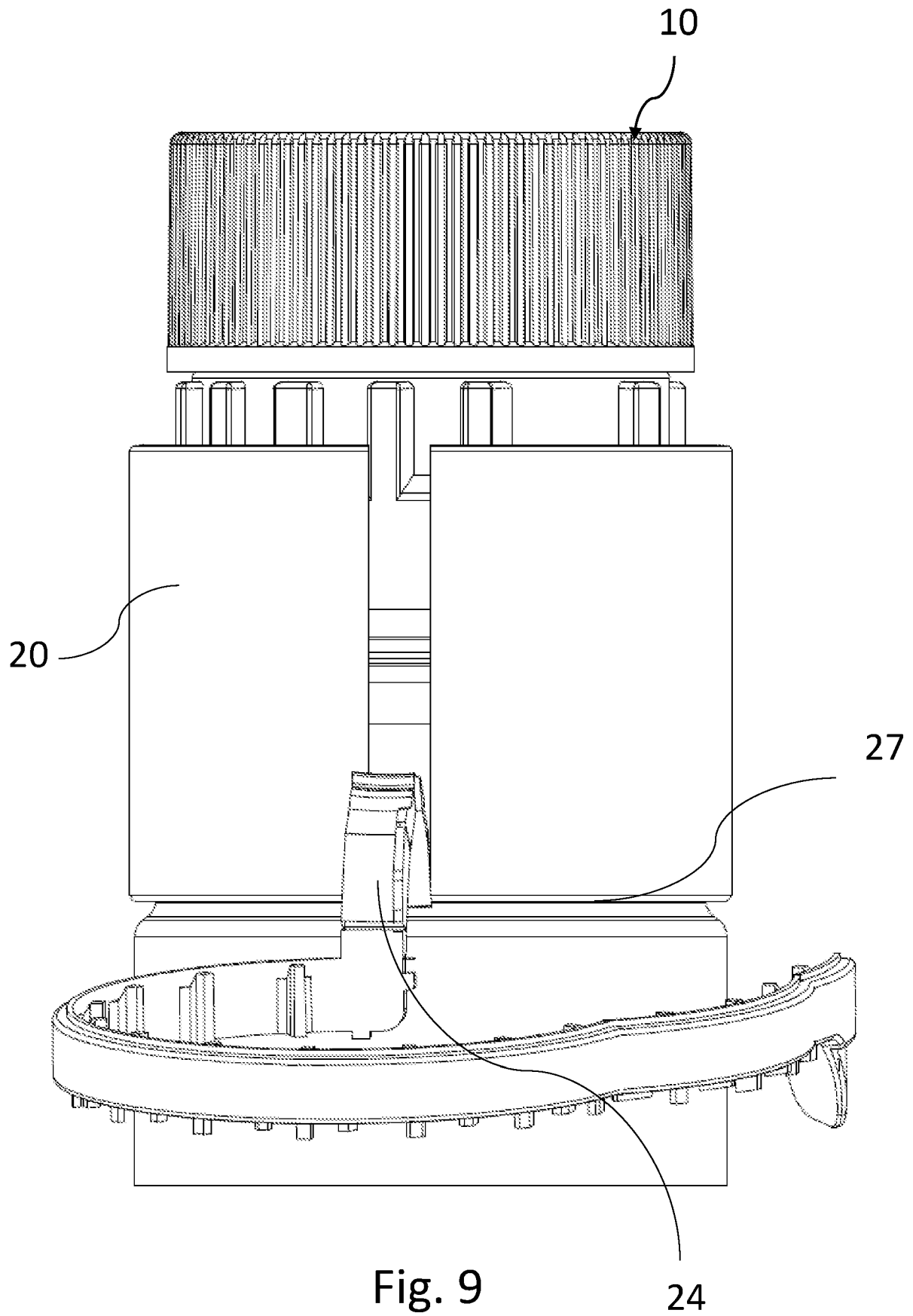

Fig. 9

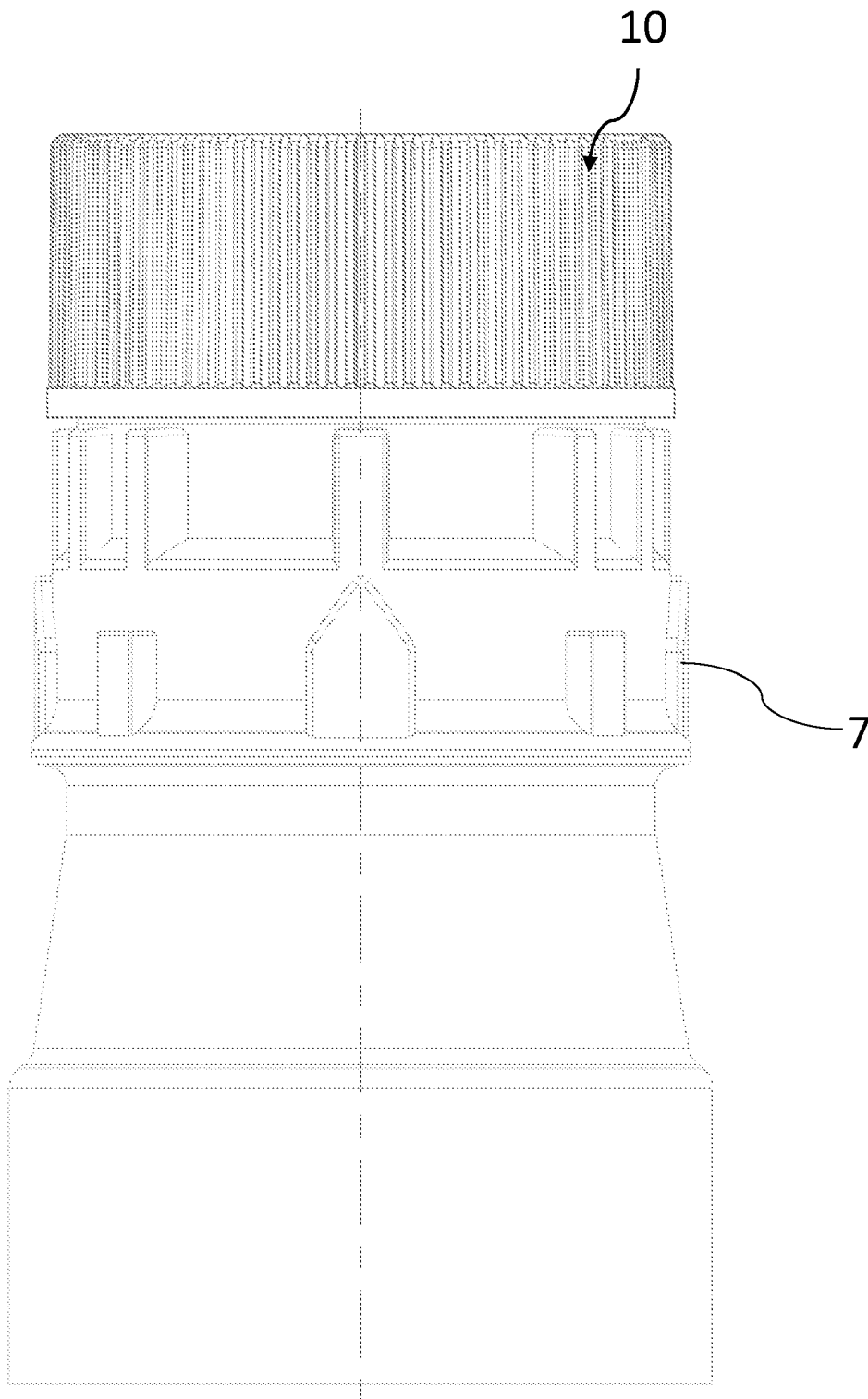

Fig. 10

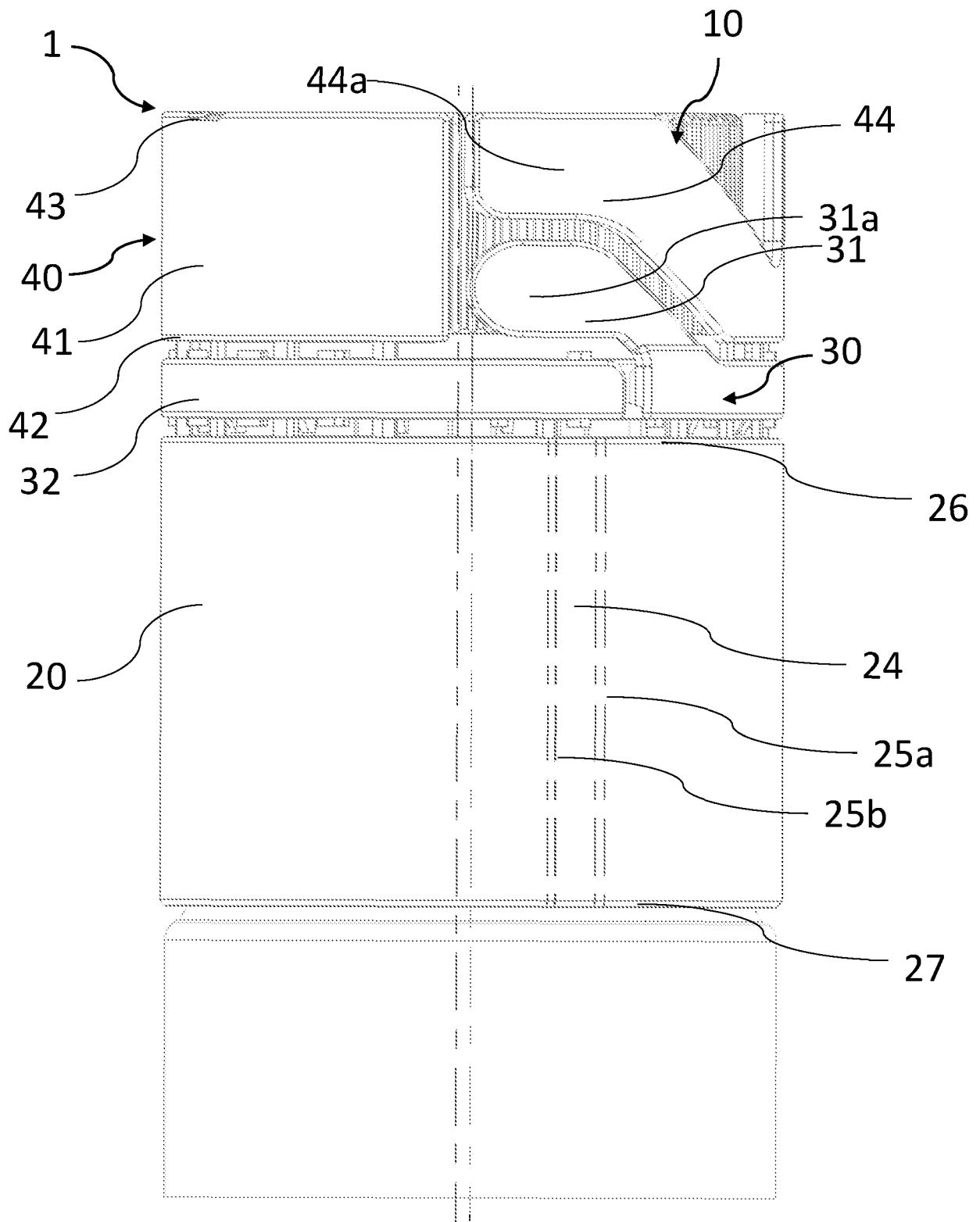

Fig. 11

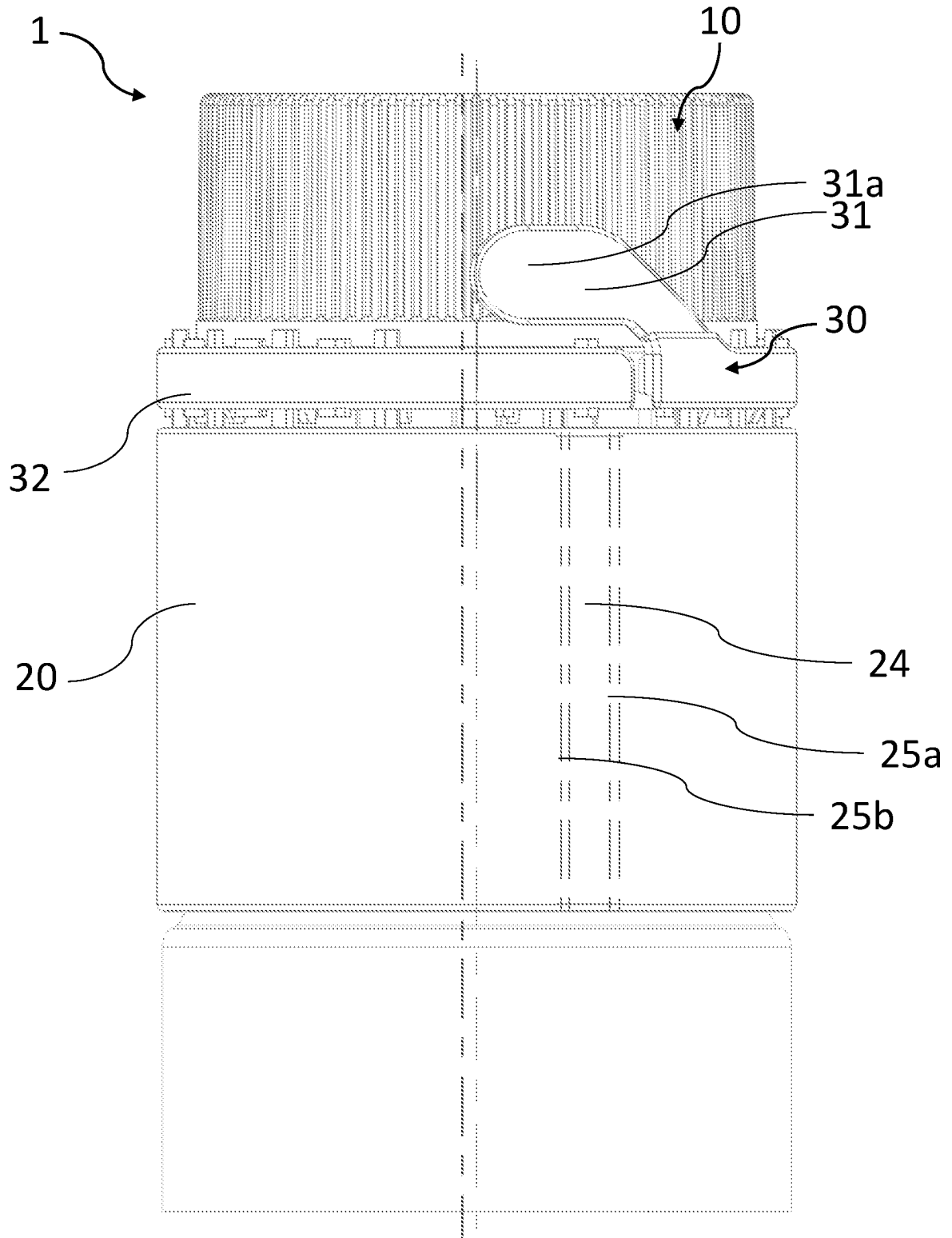

Fig. 12

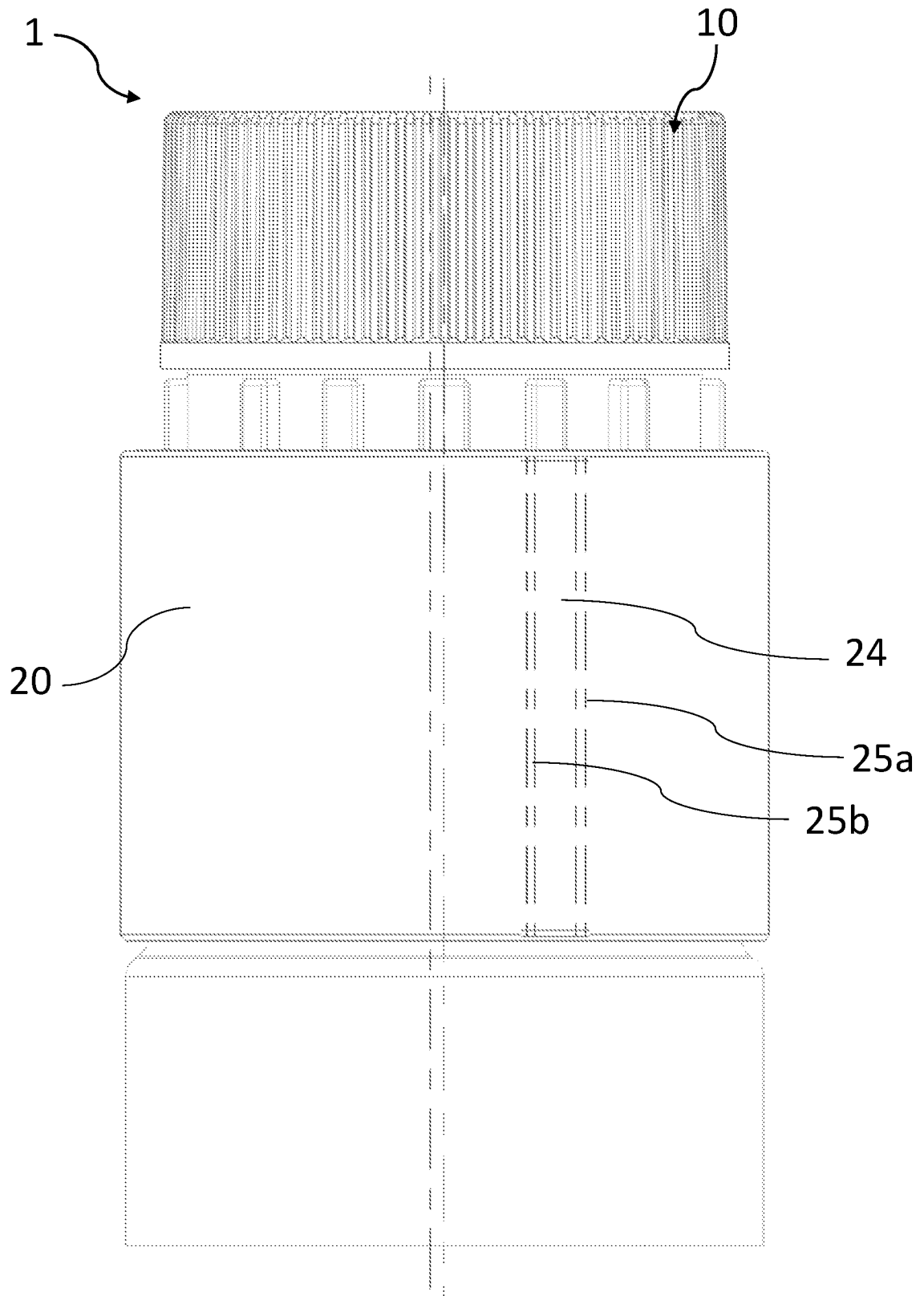

Fig. 13

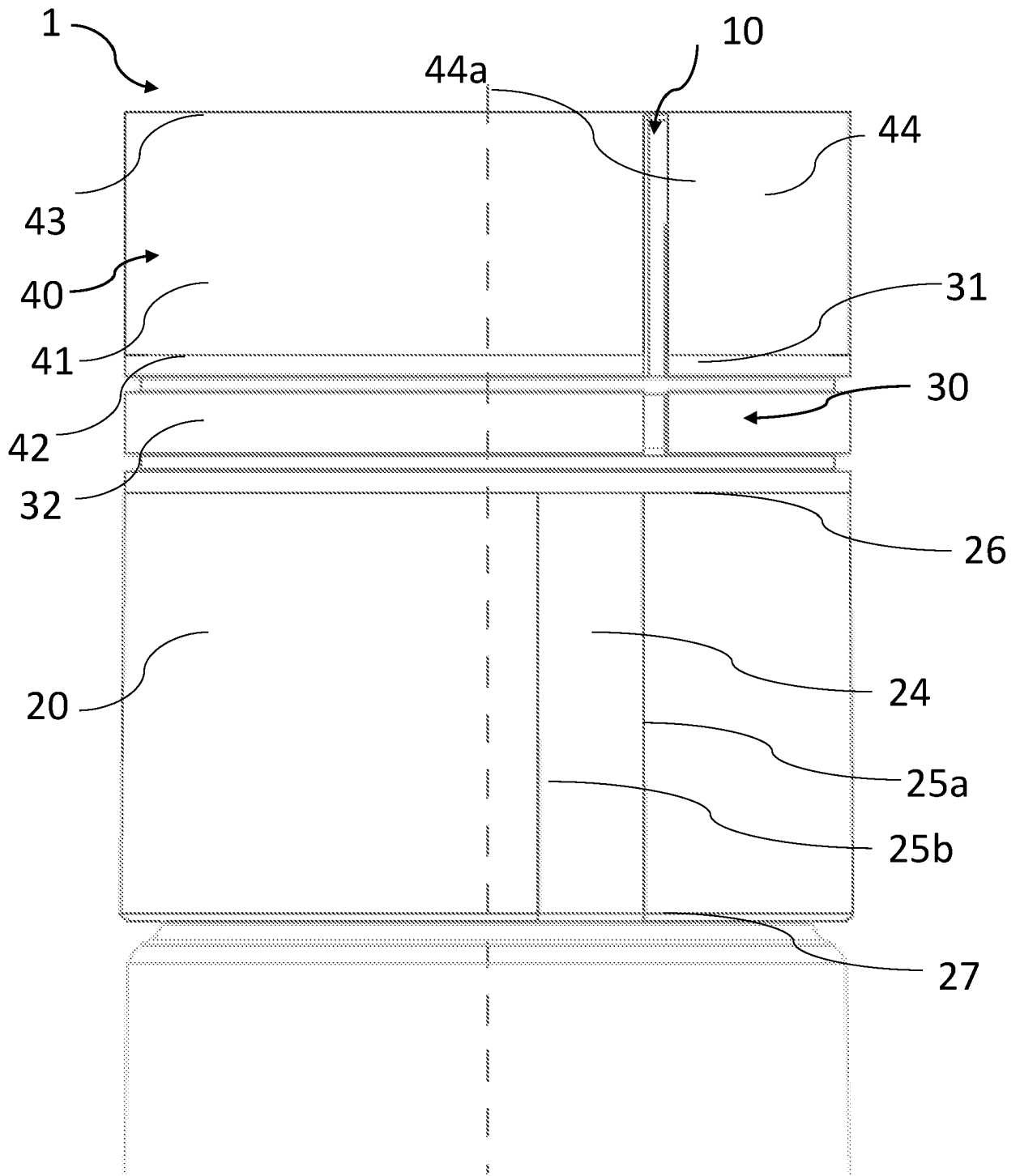

Fig. 14

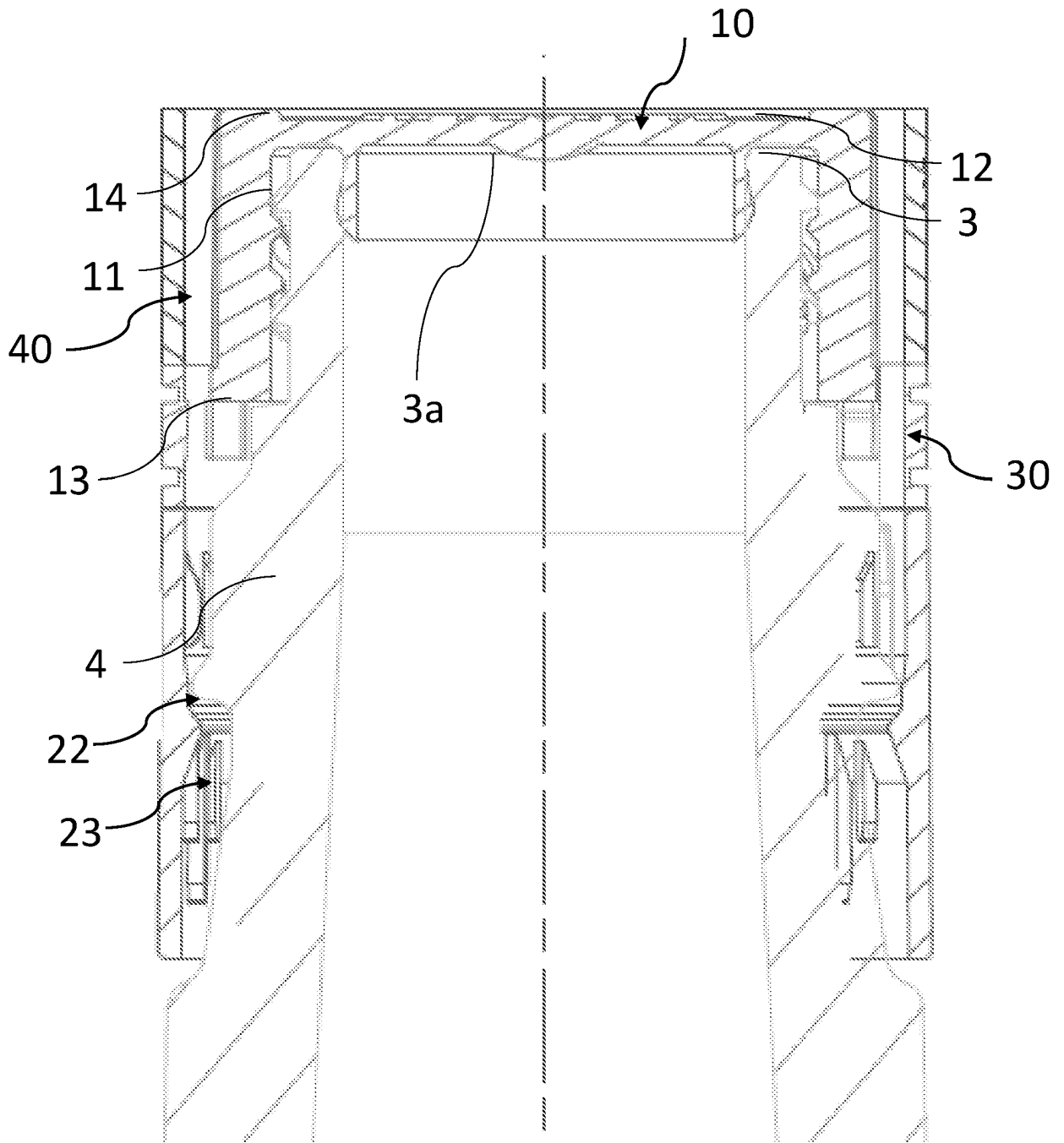

Fig. 15

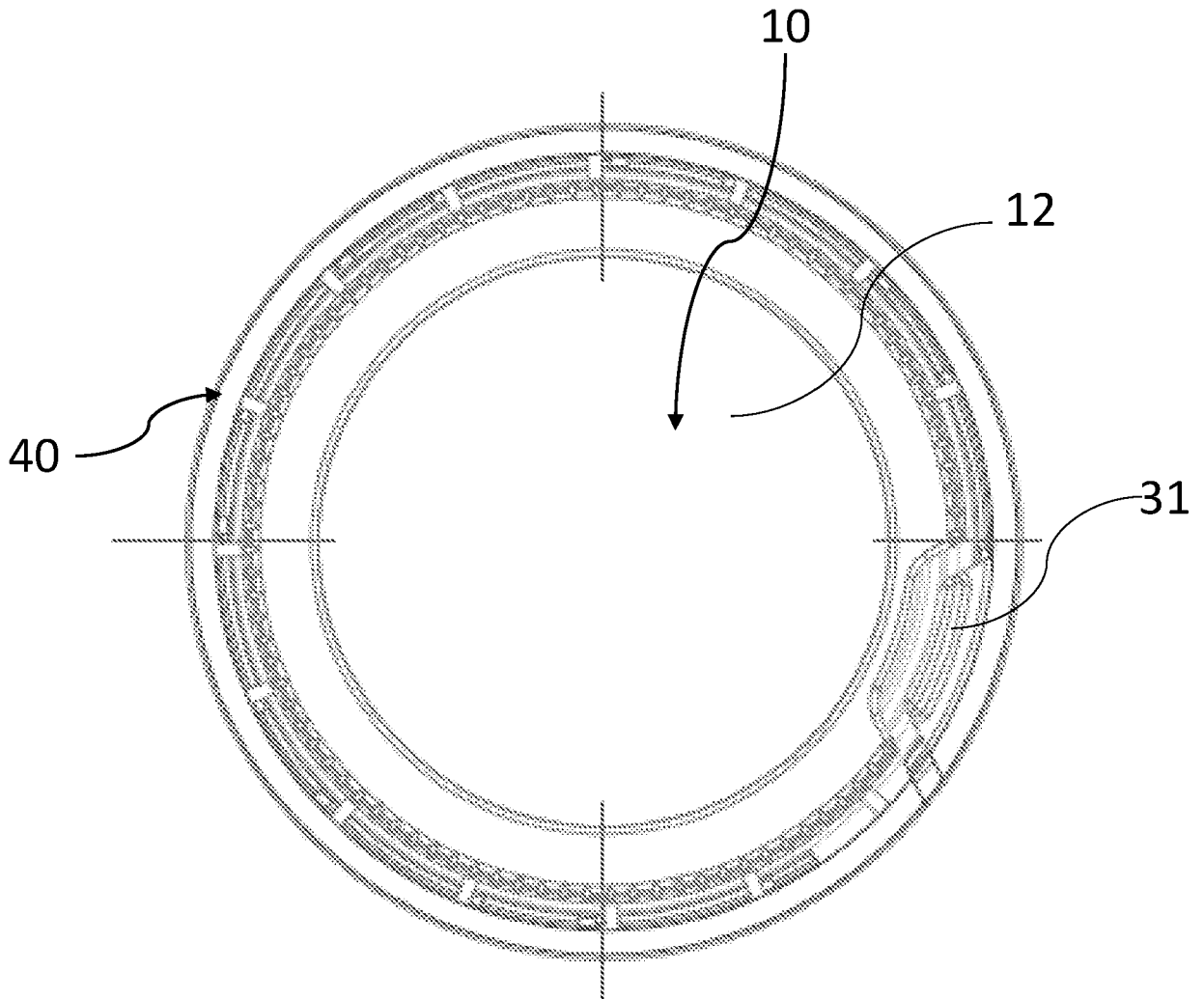

Fig. 16

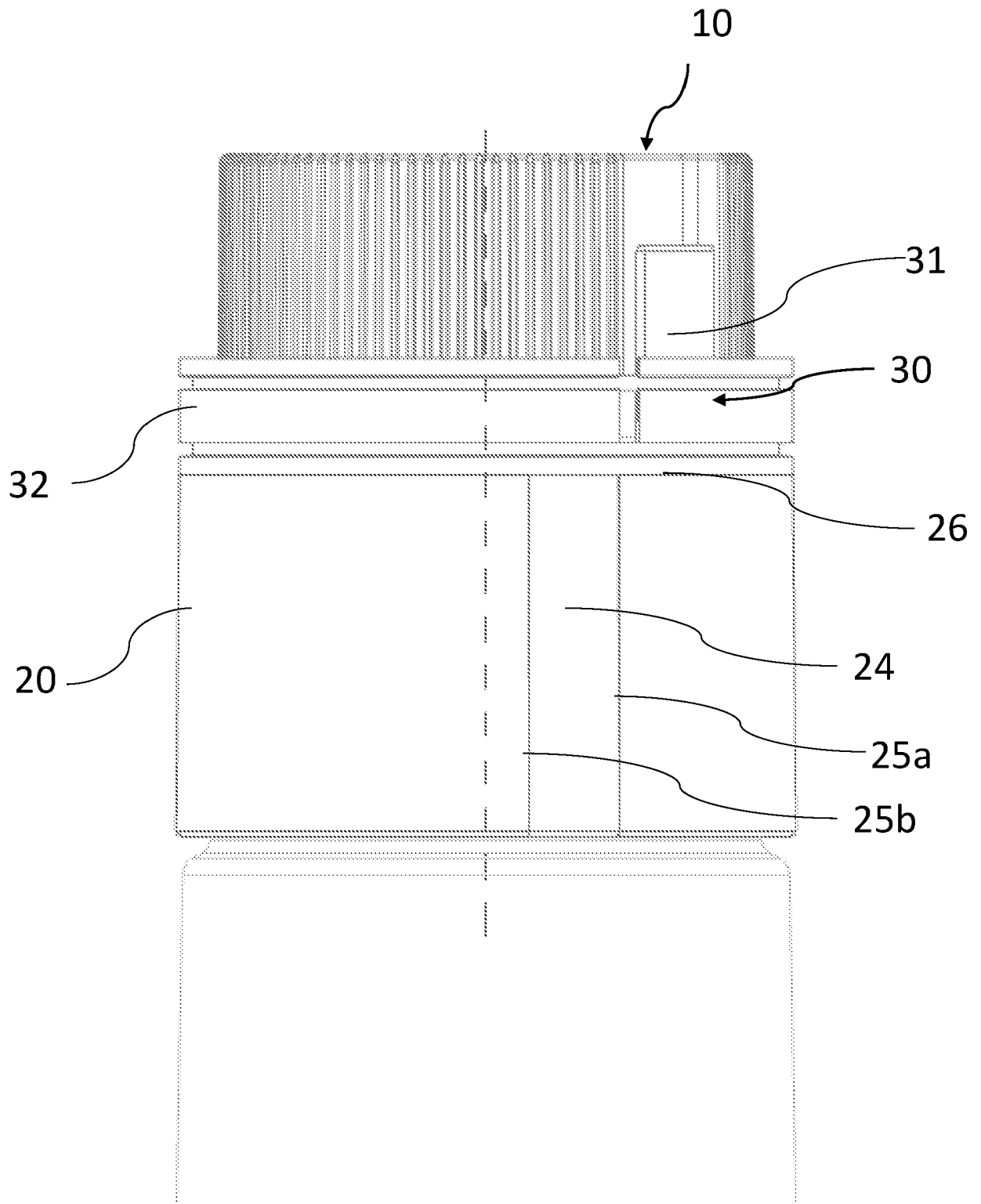

Fig. 17

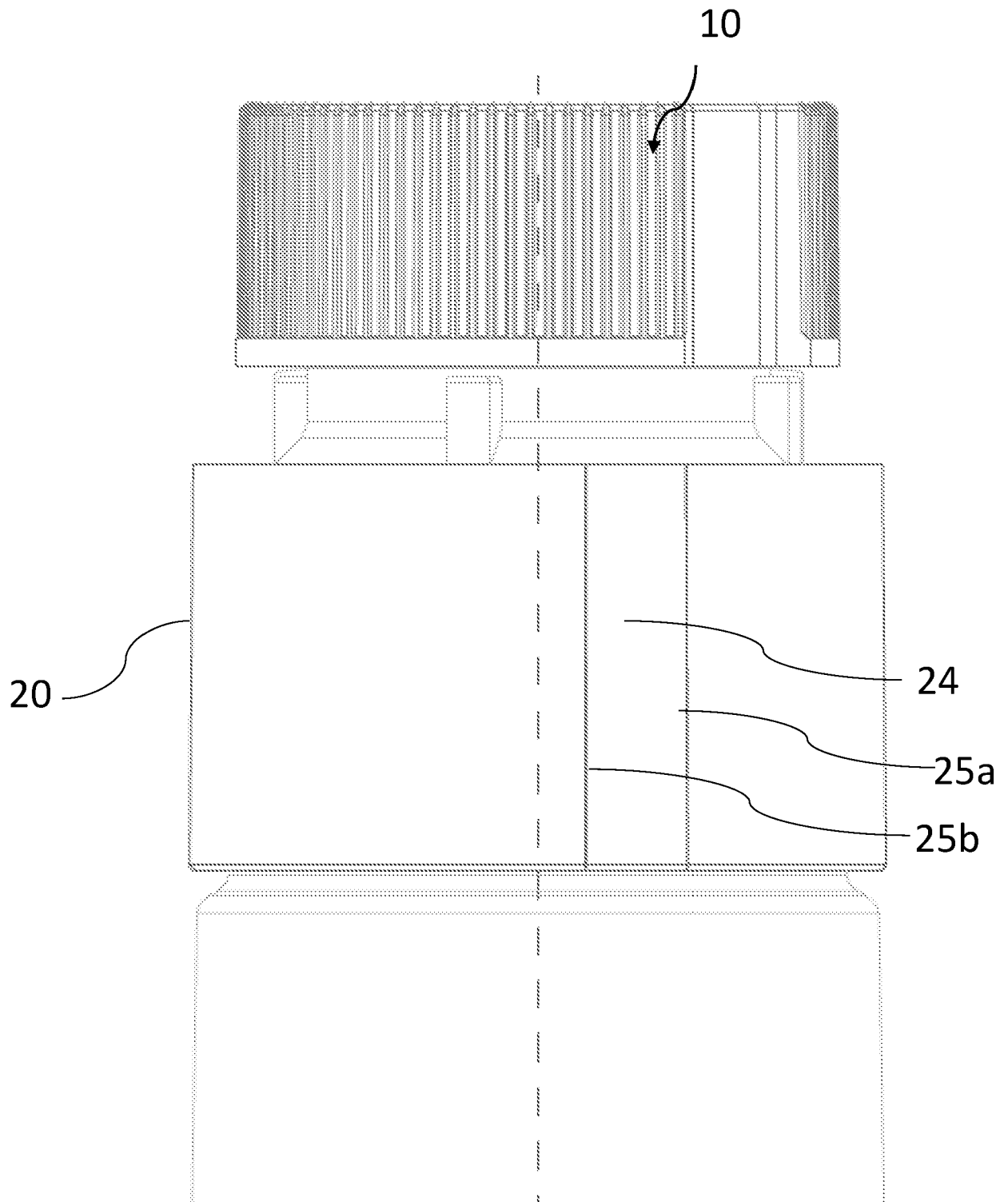

Fig. 18

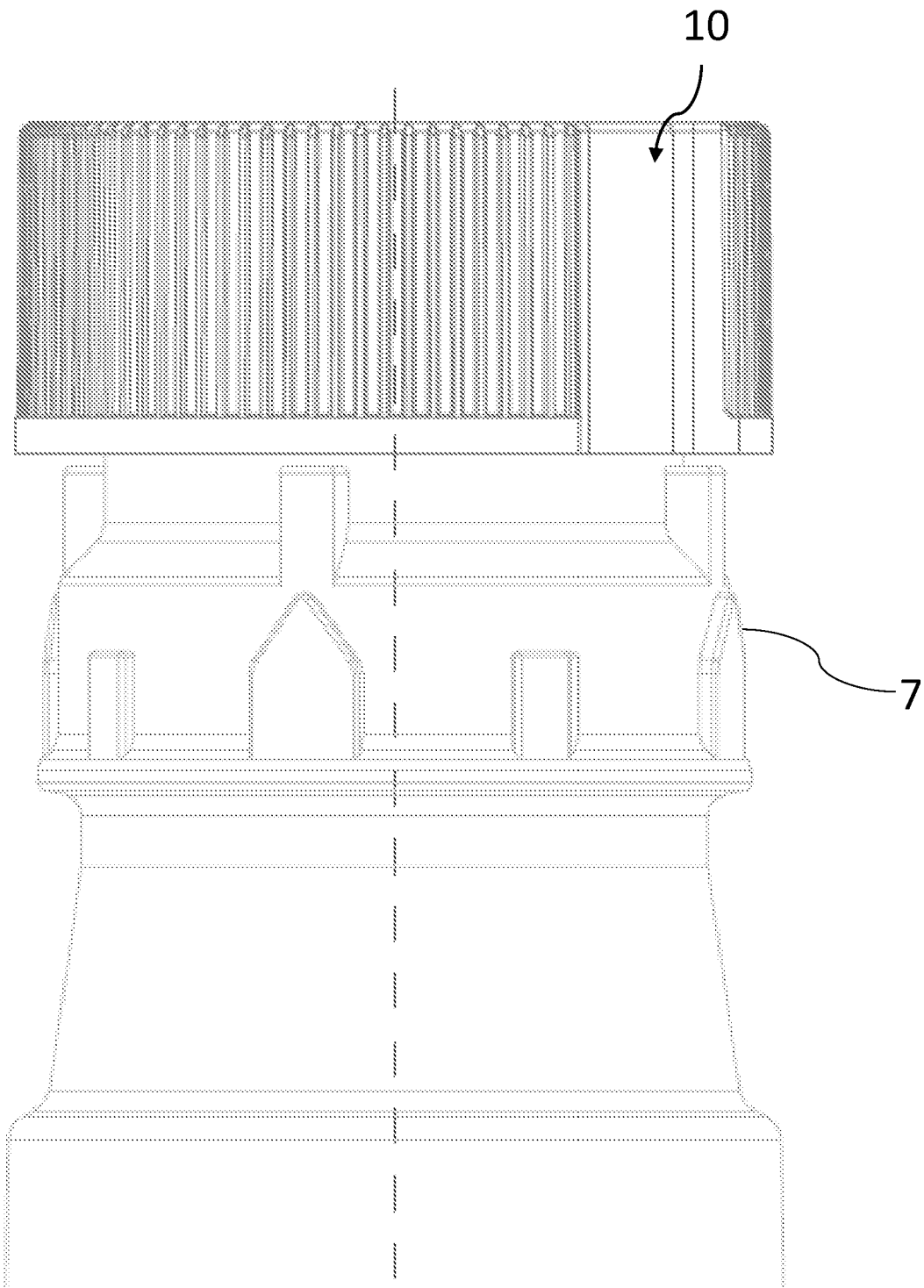

Fig. 19

REFERENCES CITED IN THE DESCRIPTION

This list of references cited by the applicant is for the reader's convenience only. It does not form part of the European patent document. Even though great care has been taken in compiling the references, errors or omissions cannot be excluded and the EPO disclaims all liability in this regard.

Patent documents cited in the description

- GB 2285623 A [0003]
- EP 1818272 A [0004]
- US 5667086 A [0005] [0008]
- WO 2013132384 A [0009]
- EP 3031743 A [0010]
- EP 2897876 A [0010]
- EP 3397567 A [0010]
- US 2016167840 A [0010]