



(12) **EUROPEAN PATENT APPLICATION**

- (43) Date of publication: **01.11.2023 Bulletin 2023/44**
- (51) International Patent Classification (IPC):
D03C 13/00 (2006.01)
- (21) Application number: **23196030.3**
- (52) Cooperative Patent Classification (CPC):
D03C 13/025
- (22) Date of filing: **03.12.2019**

- (84) Designated Contracting States:
AL AT BE BG CH CY CZ DE DK EE ES FI FR GB GR HR HU IE IS IT LI LT LU LV MC MK MT NL NO PL PT RO RS SE SI SK SM TR
- (62) Document number(s) of the earlier application(s) in accordance with Art. 76 EPC:
19213195.1 / 3 831 991
- (71) Applicant: **Picanol**
8900 Ieper (BE)
- (72) Inventors:
 - **Adriaen, Marc**
8902 Hollebeke (BE)

- **Strubbe, Patrick**
8470 Gistel (BE)
 - **Sampers, Dirk**
8640 Oostvleteren (BE)
 - **Delboo, Emmanuel**
8560 Wevelgem (BE)
- (74) Representative: **Patentanwälte**
Ruff, Wilhelm, Beier, Dauster & Partner mbB
Kronenstraße 30
70174 Stuttgart (DE)

Remarks:
This application was filed on 07-09-2023 as a divisional application to the application mentioned under INID code 62.

(54) **DRIVING DEVICE FOR A SHEDDING UNIT AND METHOD FOR ADJUSTING A SHED STROKE**

(57) The invention relates to a driving device for a shedding unit (1) and a method for adjusting a shed stroke of a driving device (5) for a shedding unit (1), the driving device (5) comprising a rotationally mounted drive element (16), a crank (6), and a locking unit (30), wherein for a rotation about the axis of rotation (17) of the drive element (16) together with the drive element (16), the crank (6) is releasably lockable to the drive element (16) in different angular positions with respect to the drive element (16) by the locking unit (30), and wherein when the crank (6) is unlocked from the drive element (16), for adjusting the angular position of the crank (6) with respect to the drive element (16), the driving device (5) is config-

ured to move the drive element (16) about an axis of rotation (17) of the drive element (16) for causing a relative movement between the drive element (16) and the crank (6) about a seat axis (22), a movement of a distal end (24) of the crank (6) is restricted to a movement along a defined path, when unlocking the crank (6) from the drive element (16) and moving the drive element (16) about the axis of rotation (17) of the drive element (16). The invention further relates to a computer program comprising instructions which, when the program is executed by a computer, cause the computer to carry out the method for adjusting a shed stroke of a driving device for a shedding unit.

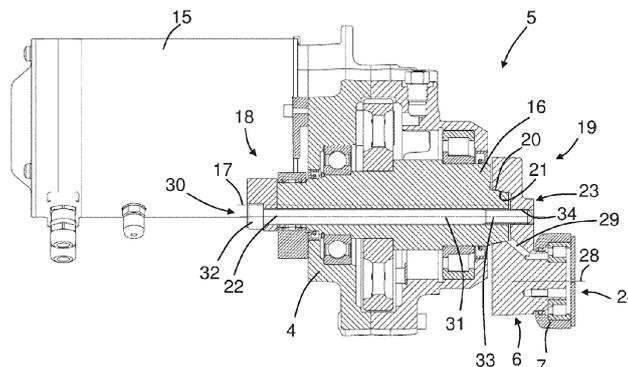

Fig. 5

Description

TECHNICAL FIELD AND PRIOR ART

[0001] The invention relates to a driving device for a shedding unit and a method for adjusting a shed stroke of a driving device for a shedding unit. The invention further relates to a computer program comprising instructions which, when the program is executed by a computer, cause the computer to carry out the method for adjusting a shed stroke of a driving device for a shedding unit.

[0002] In the context of the application, a shedding unit is defined as a unit comprising one or more driving devices, which can be drivingly coupled to heald frames of a weaving machine for moving the heald frames up and down. For a movement of the heald frames, driving devices having a swivel lever with two or three arms are well known, wherein a rotating crank is coupled via a coupling rod to a first arm of the lever and the heald frame is coupled to a second arm of the lever. The heald frames are moved up and down with a stroke, which depends among others on the length of the crank, the length of the coupling rod, and the coupling positions of the coupling rod and the heald frame on the first arm and the second arm, respectively. In the context of the application, a shed stroke of a driving device for a shedding unit is defined as the stroke imparted by the driving device on the swivel lever or any similar connection element.

[0003] WO 2017/032556 A1 shows a shedding unit, wherein the number of driving devices of the shedding unit is the same as the number of heald frames, and each driving device is configured for moving exactly one heald frame drivingly coupled to the driving device. The driving devices each comprise a rotating crank, a swivel lever, and a coupling rod connecting the swivel lever with the crank, wherein the coupling rod is mounted to a first arm of the swivel lever by means of a mounting element. The mounting element is slidably mounted to the first arm and fixable in an adjustable mounting position at the first arm for adjusting a shed stroke of the driving device.

[0004] JPH09-112534 A shows a driving device for a shedding unit, the driving device comprising a crank constituted by two crank elements, which are connected so that the connecting angle between the two crank elements can be changed, wherein the first crank element is concentrically mounted to a driving shaft and provided with a connecting shaft, which connecting shaft is eccentric to the driving shaft, i.e. is arranged parallel but offset to the axis of rotation of the driving shaft, wherein the second crank element is mounted to the connecting shaft, and wherein the second crank element is provided with a connecting pin for a coupling rod, which connecting pin is parallel but offset to the axis of rotation of the connecting shaft. For a connection with the driving shaft, the first crank element comprises a split clamping part for clamping the driving shaft and a screw bolt arranged tangentially to the driving shaft for tightening the split clamp-

ing part. Similar, for a connection with the connecting shaft, the second crank element comprises a split clamping part for clamping the connecting shaft and a screw bolt for tightening the split clamping part. In order to adjust the shed stroke, the connecting angle between the two crank elements is changed. For this purpose, the split clamping part of the second crank element is loosened, and the second crank element is moved relative to the first crank element.

SUMMARY OF THE INVENTION

[0005] It is the object of the invention to provide a driving device, wherein a shed stroke can be easily adjusted. It is further the object of the invention, to provide a method for adjusting a shed stroke as well as a computer program comprising instructions which, when the program is executed by a computer, cause the computer to carry out the method for adjusting a shed stroke of a driving device for a shedding unit.

[0006] According to a first aspect, a driving device for a shedding unit is provided, the driving device comprising a rotationally mounted drive element, a crank, and a locking unit, wherein the drive element has an axis of rotation, a first end, and a second end, wherein the first end and the second end are distanced from each other in the direction of the axis of rotation of the drive element, wherein the drive element is provided at the second end with a seat, wherein the crank is provided with a coupling element, which coupling element cooperates with the seat for mounting the crank to the drive element so as to be rotatable about a seat axis of the seat, which seat axis is parallel but offset to the axis of rotation of the drive element, wherein for a rotation about the axis of rotation of the drive element together with the drive element, the crank is releasably lockable to the drive element in different angular positions with respect to the drive element by the locking unit, and wherein when the crank is unlocked from the drive element, for adjusting the angular position of the crank with respect to the drive element, the driving device is configured to move the drive element about the axis of rotation of the drive element for causing a relative movement between the drive element and the crank about the seat axis.

[0007] In the context of the application, a rotary movement of an element about an axis is referred to as movement about an axis, wherein the movement may be less or more than a full rotation about the axis.

[0008] In one embodiment, the driving devices are used in a shedding unit, wherein the number of driving devices of the shedding unit is the same as the number of heald frames. In other words, each driving device is configured for moving exactly one heald frame drivingly coupled to the driving device. However, it is generally conceivable within the context of the application to couple more than one heald frame to a common driving device, wherein the driving device in one embodiment is configured to move two heald frames in opposite directions.

[0009] The driving device according to the application allows for an easy adjustment of the shed stroke. In prior art document JPH09-112534 A, the drive element and the crank are referred to as first crank element and second crank element, respectively. In contrast to JPH09-112534 A, for an adjustment of the angular position between the drive element and the crank, when the crank is unlocked from the drive element, according to the application the drive element and not the crank, to which a head frame can be coupled, is moved.

[0010] In one embodiment, a drive motor is provided, which drive motor is configured to drive the drive element so as to move about the axis of rotation of the drive element. The drive motor is driving the drive element to rotate about the axis of rotation together with the crank for an up and down movement of a head frame coupled to the driving device. In addition, when the crank is unlocked from the drive element, the drive motor can be used for displacing or moving the drive element by a certain angle about the axis of rotation for an adjustment of the angular position of the crank with respect to the drive element.

[0011] In one embodiment, the locking unit allows for an automated operation. For example, in one embodiment, the locking unit is in the form of a hydraulic expansion chuck, wherein a hydraulic pressure acting between the seat and the coupling element can be varied for locking the crank to the drive element or unlocking the crank from the drive element. In an alternative embodiment, the locking unit is in the form of a pneumatic and/or hydraulic actuable clutch. In still another embodiment, the locking unit comprises at least one pneumatic and/or hydraulic cylinder and a return spring, which cylinder is moveable for unlocking the locking unit by applying a pneumatic and/or hydraulic pressure.

[0012] In alternative or in addition, the locking unit is manually operable, wherein in one embodiment the locking unit is accessible for a manual operation from a first end of the drive element for locking the crank to the drive element or for unlocking the crank from the drive element. For example, the shedding unit comprises a plurality of driving devices, which are arranged in two opposing groups, wherein the second ends of the drive elements of the two groups are facing towards a center of the shedding unit. In this case, the first ends are arranged at an outer side of the shedding unit and more easily accessible for an operator, than the second ends. This first end allows for an easy access for an operator for an adjustment of the shed stroke.

[0013] In one embodiment, the coupling element and the seat are arranged for locking the crank to the drive element by forcing the crank and the drive element towards each other in the direction of the seat axis, wherein the locking unit is actuable for causing a movement of the crank towards or away from the drive element in the direction of the seat axis.

[0014] In one embodiment, one of the coupling element and the seat is a member in the form of a truncated cone and the other one is a complementary receiving bushing.

In other words, a conical seat connection is provided, which is backlash-free and self-centering. In addition, a locking and unlocking is possible by moving the coupling element a short distance with respect to the seat.

[0015] In one embodiment, the locking unit comprises a locking pin, which locking pin is moveably mounted to the drive element and is moveable in one direction for locking the crank to the drive element and in an opposite direction for unlocking the crank from the drive element. In one embodiment, the locking pin is slidably supported. In alternative or in addition, the locking pin is rotatably supported. In preferred embodiments, the locking pin has an actuating end configured to receive an actuating force for moving the locking pin with respect to the drive element, which actuating end is arranged at the first end of the drive element. The actuating end in one embodiment is provided with a screw head for the application of a rotational movement and/or a torque.

[0016] In one embodiment, the locking pin is mounted to the drive element so as to be longitudinally moveable along the seat axis, wherein the crank can be coupled to the locking pin for movement with the locking pin along the seat axis, for causing a movement of the crank towards or away from the drive element in the direction of the seat axis by axial movement of the locking pin. In one embodiment, the locking pin is forced in a locking position using a restoration element and is moveable against the force of a restoration element using for example a pneumatic and/or hydraulic cylinder.

[0017] In other embodiments, the locking unit comprises a locking pin that is mounted to or arranged in the drive element so as to be rotatable about the seat axis, wherein the locking pin is provided with an actuating end configured to receive an actuating force for moving the locking pin with respect to the drive element, and wherein the locking pin is provided with a threaded end opposite to the actuating end, which threaded end cooperates with a threaded hole of the crank for causing a movement of the crank towards or away from the drive element in the direction of the seat axis by rotating the locking pin. In other words, the locking pin and the crank act as a spindle drive causing a movement of the crank in the direction of the seat axis by rotating the locking pin about the seat axis.

[0018] The coupling element is provided at a proximal end of the crank, wherein a subsequent link such as a connecting rod is coupled to a distal end of the crank, for example using a hinged joint. In the context of the invention, a proximal end and a distal end of a crank are defined as the regions of the crank in which the crank can be coupled to a drive element and a subsequent link, such as a connecting rod, respectively. The length of the crank may be chosen such that a part of the crank extends beyond the proximal end and/or the distal end. In one embodiment, the distal end is not coupled to any element when adjusting a shed stroke, wherein the distal end is free to move. In preferred embodiments, a movement of a distal end of the crank is restricted to movement along

a defined path upon adjusting the shed stroke. When unlocking the crank from the drive element, and restricting a movement of the distal end of the crank to a defined path while moving the drive element about the axis of rotation of the drive element, a movement of the drive element about the axis of rotation of the drive element causes a defined adjustment of the angular position of the crank with respect to the drive element.

[0019] In embodiments, the driving device further comprising a link coupled with its first end to the distal end of the crank by a hinged joint, wherein when the crank is unlocked from the drive element, the drive element, the crank and the link together form a planar quadrilateral linkage. When adjusting the angular position of the crank with respect to the drive element, a second end of the link can be held fixed in position while moving the drive element about the axis of rotation of the drive element, and allowing the link to rotate about the second axis, thereby restricting the movement of the distal end of the crank about the seat axis.

[0020] In embodiments, the driving device further comprising a swivel lever having a first arm and a second arm, wherein the swivel lever is swivelable to-and-fro about a swivel axis between a first position associated with an upper position of a heald frame coupled to the swivel lever and a lower position associated with a lower position of the heald frame coupled to the swivel lever, a coupling rod, which is linked to the crank by a first hinged joint, wherein the coupling rod is linked to the first arm of the swivel lever by a second hinged joint, wherein for adjusting the angular position of the crank with respect to the drive element, the second hinged joint, the swivel lever and/or the heald frame coupled to the driving device is/are held in position while moving the drive element about the axis of rotation of the drive element, thereby restricting the movement of the distal end of the crank to a defined path.

[0021] According to a second aspect, a weaving machine with such a driving device is provided.

[0022] According to a third aspect, a method for adjusting a shed stroke of a driving device for a shedding unit is provided, the driving device comprising a rotationally mounted drive element, a crank, and a locking unit, wherein the drive element has an axis of rotation, a first end, and a second end, wherein the first end and the second end are distanced from each other in the direction of the axis of rotation of the drive element, wherein the drive element is provided at the second end with a seat, wherein the crank is provided with a coupling element, which coupling element cooperates with the seat for mounting the crank to the drive element so as to be rotatable about a seat axis of the seat, which seat axis extends parallel but offset to the axis of rotation of the drive element, wherein for a rotation about the axis of rotation of the drive element together with the drive element the crank is releasably lockable to the drive element in different angular positions with respect to the drive element by the locking unit, wherein when the crank is

unlocked from the drive element, for adjusting the angular position of the crank with respect to the drive element, the drive element is moved about the axis of rotation of the drive element for causing a relative movement between the drive element and the crank about the seat axis.

[0023] In one embodiment, the drive element is driven to move about the axis of rotation of the drive element by a drive motor when the crank is unlocked from the drive element for adjusting the angular position of the crank with respect to the drive element.

[0024] As mentioned above, in embodiments, a movement of the distal end of the crank is restricted while moving the drive element, for example due to a link coupled to the distal end of the crank, which together with the drive element and the crank forms a planar quadrilateral linkage when the crank is unlocked from the drive element.

[0025] In one embodiment, a heald frame coupled to the crank is held in position while driving the drive element so as to move, in particular so as to rotate, about the axis of rotation of the drive element when the crank is unlocked from the drive element for restricting a movement of the distal end of the crank.

[0026] In one embodiment, for adjusting the angular position of the crank with respect to the drive element, the drive element is moved about the axis of rotation of the drive element in a direction associated with an upward movement of the heald frame coupled to the crank. In this case, gravitational forces acting on the heald frame coupled to the driving device can be used for holding the heald frame in position while moving the drive element when the crank is unlocked from the drive element.

[0027] According to a fourth aspect, a computer program comprising instructions which, when the program is executed by a computer, cause the computer to carry out the method for adjusting a shed stroke of a driving device comprising a drive element and a crank by moving the drive element about its axis of rotation when the crank is unlocked from the drive element.

[0028] In one embodiment, the computer program further comprises instructions which, when the program is executed by the computer, cause the computer to determine a direction of rotation of the drive element associated with an upward movement of a heald frame coupled to the crank.

[0029] In one embodiment, the computer program further comprises instructions which, when the program is executed by the computer, cause the computer to determine a reference angular position of the crank with respect to the drive element for setting a desired stroke of the heald frame coupled to the crank. In case the movement of the distal end of the crank is restricted when moving the drive element along a known path, the computer program may further comprise instructions which, when the program is executed by the computer, cause the computer to determine a necessary movement of the drive element about the axis of rotation for achieving a

relative movement of the crank with respect to the drive element into said reference angular position.

BRIEF DESCRIPTION OF THE DRAWINGS

[0030] In the following, embodiments of the invention will be described in detail with reference to the drawings. Throughout the drawings, the same or similar elements will be denoted by the same reference numerals.

- Fig. 1 shows in a perspective view a driving device for a shedding unit and a heald frame coupled to the driving device;
- Fig. 2 shows in a front view the driving device and the heald frame of Fig. 1;
- Fig. 3 shows in a perspective view a shedding unit comprising several driving devices;
- Fig. 4 shows in a perspective view one driving device of the shedding unit of Fig. 3;
- Fig. 5 shows a cross-sectional view of the driving device of Fig. 4;
- Fig. 6 shows in a perspective view the driving device of Fig. 4 together with a tool for actuating the locking unit;
- Fig. 7 shows a schematic front view of a drive element and a crank of a driving device, wherein the crank is arranged in a first angular position with respect to the drive element; and
- Fig. 8 shows a schematic front view of a drive element and a crank of a driving device of Fig. 7, wherein the crank is arranged in a second angular position with respect to the drive element, which second angular position is different from the first angular position.

DETAILED DESCRIPTION OF THE DRAWINGS

[0031] Figs. 1 and 2 show a shedding unit 1 and a heald frame 2 of a weaving machine. Although only one heald frame 2 is visible, the weaving machine comprises a number of heald frames 2, which are guided in a frame guide (not shown) of the weaving machine and driven to move up and down.

[0032] As shown in the perspective view of Fig. 3, the shedding unit 1 comprises several driving devices 5, wherein the number of driving devices 5 in the embodiment shown is the same as the number of heald frames 2. In other words, one driving device 5 is assigned to one heald frame 2, which heald frame 2 is coupled to the associated one driving device 5. In the embodiment shown in Fig. 3, the shedding unit 1 comprises eight driv-

ing devices 5 according to the invention. In an alternative embodiment, a different number of driving devices may be provided, for example a number of sixteen driving devices as shown in WO 2017/032556 A1. In an embodiment, a shedding unit 1 having a number of driving devices 5 can also be used for driving a number of heald frames 2 which is less than the number of driving devices 5, wherein a number of driving devices 5 are not used during weaving.

[0033] The driving devices 5 each comprise a crank 6, which is driven to rotate about an axis of rotation 17 (see Fig. 4), a coupling rod 7, and a first swivel lever 8. The first swivel lever 8 is swivelable to-and-fro about a swivel axis 9 between an upper position and a lower position. The swivel axis 9 is arranged stationary in a support 26. The driving device 5 shown in Fig. 1 further comprises a second swivel lever 10, that is swivelable to-and-fro about a second swivel axis 12 between an upper position and a lower position. The second swivel lever 10 is linked to the first swivel lever 8 by means of a connecting rod 11 and driven by the first swivel lever 8 to conjointly move with the first swivel lever 8. In the embodiment of Fig. 1, for example, the heald frame 2 is linked to the first swivel lever 8 by means of a first lifting rod 13 and to the second swivel lever 10 by means of a second lifting rod 14. In an alternative embodiment, preferably in case of wide heald frames, more than two swivel levers, associated connecting rods and associated lifting rods can be provided.

[0034] As generally known, for moving the heald frames 2 up and down, the crank 6 is driven to rotate about an axis of rotation 17, thereby causing a to-and-fro movement of the first swivel lever 8 about the swivel axis 9. Each driving device 5 comprises a drive motor 15, wherein the driving devices 5 are arranged in the shedding unit 1 such that the drive motors 15 are arranged at an outer side of the shedding unit 1 and the coupling rods 7 are arranged close to one another. In a preferred embodiment, the coupling rod 7 and the connecting rod 11 extend almost in line with each other, so that forces on the swivel axis 9 applied by the swivel lever 8 are minimized. In alternative embodiments, other coupling rods and associated connecting rods can be used, for example coupling rods and connecting rods as shown in WO 2004/092465 A1.

[0035] Figs. 4 and 5 show a driving device 5 for a shedding unit 1 comprising a drive motor 15, a crank 6, a rotationally mounted drive element 16 (see Fig. 5), and a locking unit 30 (see Fig. 5). The drive element 16 is mounted via bearings in a support frame 4. The rotationally mounted drive element 16 has an axis of rotation 17, a first end 18, and a second end 19, wherein the first end 18 and the second end 19 are distanced from each other in the direction of the axis of rotation 17 of the drive element 16. The drive motor 15 is configured to drive the drive element 16 so as to move the drive element 16 about the axis of rotation 17 of the drive element 16. The drive motor 15 is arranged at the first end 18 of the drive element 16.

[0036] The crank 6 is coupled at its proximal end 23 to the drive element 16 and at its distal end 24 to the coupling rod 7. The coupling rod 7 can rotate about an axis of rotation 28 of the crank 6. At the second end 19 of the drive element 16, the drive element 16 is provided with a seat 20, which seat 20 in the embodiment shown is a member in the form of a truncated cone. The crank 6 is provided with a coupling element 21, which coupling element 21 in the embodiment shown is a receiving bushing, which is complementary in shape to the truncated cone of the seat 20. The coupling element 21 cooperates with the seat 20 for mounting or coupling the crank 6 to the drive element 16. The coupling element 21 and the seat 20 are arranged for locking the crank 6 to the drive element 16 by forcing the crank 6 and the drive element 16 towards each other in the direction of the seat axis 22, wherein the locking unit 30 is actuatable for causing a movement of the crank 6 towards or away from the drive element 16 in the direction of the seat axis 22. Thus, when the crank 6 is unlocked from the drive element 16, the crank 6 and the drive element 16 are rotatable relative to each other about a seat axis 22 of the seat 20, which seat axis 22 is parallel but offset to the axis of rotation 17 of the drive element 16. When the crank 6 is locked to the drive element 16, the drive element 16 can be driven by the drive motor 15 to rotate together with the crank 6 about the axis of rotation 17 of the drive element 16 for causing an up and down movement of a heald frame 2 (see Fig. 1) coupled to the crank 6.

[0037] In an alternative embodiment, one of the coupling element and the seat is a member in the form of a cylinder and the other one is a complementary receiving bushing, wherein for example the front end of the cylinder and the base of the receiving bushing can be forced towards each other for locking the drive element 16 to the crank 6.

[0038] The locking unit 30 is configured to releasably lock the crank 6 to the drive element 16 in different angular positions with respect to the drive element 16. The locking unit 30 can also be referred as a fastening unit for releasably fastening the drive element 16 to the crank 6. In the embodiment shown in Fig. 4 and 5, the locking unit 30 comprises a locking pin 31, which is arranged in the drive element 16 concentric to the seat axis 22 of the seat 20 so as to be rotatable about the seat axis 22. The locking pin 31 has an actuating end 32 arranged at the first end 18 of the drive element 16, so that the actuating end 32 of the locking unit 30 is accessible for a manual operation from the first end 18 of the drive element 16 for locking the crank 6 to the drive element 16 or for unlocking the crank 6 from the drive element 16. Opposite to the actuating end 32 of the locking pin 31, the locking pin 31 is provided with a threaded end 33. The threaded end 33 cooperates with a threaded hole 34 of the crank 6 for causing a movement of the crank 6 towards or away from the drive element 16 in the direction of the seat axis 22 by rotating the locking pin 31 about the seat axis 22, thereby locking the crank 6 to the drive element 16 or

unlocking the crank 6 from the drive element 16. Further, a grease duct 29 is provided allowing to grease the bearing at the distal end 24, which grease duct 29 allows to guide grease that is supplied along the locking pin 31.

[0039] Fig. 6 shows in a perspective view the driving device of Fig. 4 together with a tool 40 for actuating the actuating end 32 of the locking unit 30. As described above, the locking unit 30 comprises a locking pin 31 (see Fig. 5), which is moveably mounted to the drive element 16 and is moveable in one direction for locking the crank 6 to the drive element 16 and in an opposite direction for unlocking the crank 6 from the drive element 16. The locking pin 31 has an actuating end 32 configured to receive an actuating force by the tool 40 for moving the locking pin 31 with respect to the drive element 16, which actuating end 32 is arranged at the first end 18 of the drive element 16. As described above, the locking pin 31 is provided with the threaded end 33 (see Fig. 5) cooperating with the threaded hole 34 of the crank 6, thus allowing to apply a torque by the tool 40 on the actuating end 32 of the locking pin 31 to move or rotate the locking pin 31, and to thereby move the crank 6 towards or away from the drive element 16 in the direction of the seat axis 22.

[0040] The crank 6 is releasably lockable to the drive element 16, so that the crank 6 can be unlocked from the drive element 16 for a relative movement between the crank 6 and the drive element 16 in order to adjust the shed stroke, and so that the crank 6 can be locked to the drive element 16 in different angular positions with respect to the drive element 16 for a conjoint movement allowing an up and down movement of a heald frame 2 that is coupled to the driving device 5. By an adjustment of the angular position between the drive element 16 and the crank 6, the shed stroke of the driving device 5, i.e. a swivel movement of the first swivel lever 8 about the swivel axis 9 (see Fig. 1), and, thus, a stroke of the heald frame 2 can be set.

[0041] Figs. 7 and 8 show in a schematic front view the proximal end 23 of the crank 6 coupled to the drive element 16 and the distal end 24 of the crank 6 coupled to the coupling rod 7. The coupling rod 7 is attached to the first swivel lever 8 via a hinged joint 25 allowing the coupling rod 7 to swivel about an axis of the hinged joint 25. Further, preferably for adjusting the angular position of the crank 6 with respect to the drive element 16, in the embodiment shown in Fig. 7, a movement of the first swivel lever 8 about the swivel axis 9 is blocked by means of a blocking element 27 as schematically shown in Figs. 7 and 8. Hence, when the crank 6 is unlocked from the drive element 16 for a relative movement between the crank 6 and the drive element 16, the drive element 16, the crank 6 and the coupling rod 7 form a planar quadrilateral linkage. Therefore, when the drive element 16 is moved about the axis of rotation 17 of the drive element 16, a movement of the crank 6 with respect to the drive element 16 about the seat axis 22 of the seat 20 is constrained by the coupling rod 7, because the movement

of the coupling rod 7 is constrained by the first swivel lever 8. This allows to impart a defined relative movement between the drive element 16 and the crank 6 when the crank 6 is unlocked from the drive element 16. In an alternative embodiment, as shown in Figs. 1 and 2, the blocking element 27 can be provided near the second swivel lever 10, instead of near the first swivel lever 8 as shown in Figs. 7 and 8. In an alternative embodiment, the blocking element 27 can be formed as a blocking element known from WO 2018/007168 A1 of the applicant. In an alternative embodiment, a blocking element can act on another element of the shedding unit 1, for example on the connecting rod 11, on the heald frame 2, or on still another element of the shedding unit 1.

[0042] As will be explained more in detail with reference to Figs. 7 and 8, for adjusting the angular position of the crank 6 with respect to the drive element 16, the driving device 5 is configured to move the drive element 16 about the axis of rotation 17 of the drive element 16 for causing a relative movement between the drive element 16 and the crank 6 about the seat axis 22.

[0043] When the crank 6 is mounted to the drive element 16, the drive element 16 and the crank 6 rotate together about the axis of rotation 17. The coupling rod 7 is mounted to the crank 6 to rotate about an axis of rotation 28 of the crank 6. The distance between the axis of rotation 17 and the axis of rotation 28 is referred to as first eccentricity 35. The crank 6 is mounted to the drive element 16 so as to rotate about the seat axis 22 when the crank 6 is unlocked from the drive element 16. The distance between the axis of rotation 17 and the seat axis 22 is referred to as second eccentricity 36. The distance between the seat axis 22 and the axis of rotation 28 is referred to as the third eccentricity 37, also named the crank length of the crank 6. When the crank 6 is mounted to the drive element 16, the first eccentricity 35 defines a circular trajectory 38 along which the axis of rotation 28 moves, in other words the circular trajectory 38 along which the distal end 24 of the coupling rod 7 is moved by the crank 6. The seat axis 22 moves along a circular trajectory 39 by rotating the drive element 16.

[0044] The first eccentricity 35 depends on the second eccentricity 36, the third eccentricity 37, and the relative angular position between the drive element 16 and the crank 6. Fig. 7 shows in a schematic front view a first mutual positioning of the eccentricities 35, 36, 37, wherein the crank 6 or third eccentricity 37 is arranged in a first angular position with respect to the drive element 16 or the second eccentricity 36, while Fig. 8 shows the third eccentricity 37 arranged in a different second angular position with respect to the second eccentricity 36. As shown in Figs. 7 and 8, by adjusting the angular position of the third eccentricity 37 with respect to the second eccentricity 36, in other words by adjusting the angular position of the crank 6 with respect to the drive element 16 by rotating the crank 6 about the seat axis 22, the first eccentricity 35 of the driving device 5 is adjusted, and, thus, a shed stroke of the driving device 5 can be adjust-

ed.

[0045] For adjusting the angular position of the crank 6 with respect to the drive element 16, in particular for adjusting this angular position from a mutual positioning as shown in Fig. 7 to a mutual positioning as shown in Fig. 8, and, thus, in order to adjust the shed stroke, preferably the heald frame 2 (see Fig. 1) is moved to an upper position by the drive motor 15, a blocking element 27 is provided in the range of a first swivel lever 8, in particular under the first swivel lever 8, and the heald frame 2 is moved by the drive motor 15 until the first swivel lever 8 abuts against the blocking element 27.

[0046] Then, the locking pin 31 of the locking unit 30 (see Fig. 5) is rotated for unlocking the crank 6 from the drive element 16 by means of a tool 40 that cooperates with the actuating end 32 of the locking pin 31, so that the crank 6 is unlocked from the drive element 16, and so that the crank 6 is rotatable about the seat axis 22 of the seat 20 (see Fig. 5) of the drive element 16 by driving the drive element 16 by the drive motor 15. By driving the drive motor 15, the drive element 16 is moved about the axis of rotation 17 of the drive element 16, and when the crank 6 is unlocked from the drive element 16, the angular position of the crank 6 with respect to the drive element 16 can be adjusted, for example between the positions of Fig. 7 and Fig. 8. Due to the blocking element 27, the heald frame 2 coupled to the crank 6 is held in position while driving the drive element 16 by the drive motor 15, so as to move the drive element 16 about the axis of rotation 17. When the crank 6 is unlocked from the drive element 16, a movement of the distal end 24 of the crank 6 is restricted. Preferably, for adjusting the angular position of the crank 6 with respect to the drive element 16, the drive element 16 is moved by the drive motor 15 about the axis of rotation 17 of the drive element 16 in a direction associated with an upward movement of the heald frame 2 coupled to the crank 6.

[0047] After adjusting is completed, for example when the position of Fig. 8 is reached, the crank 6 is locked again to the drive element 16, for example by rotating the locking pin 31 of the locking unit 30 by means of the tool 40 (see Fig. 6). In the meanwhile, the blocking element 27 is moved away from the swivel lever 8, in other words the blocking element 27 is displaced so that the blocking element 27 cannot make any contact with the first swivel lever 8 and does not hinder the movement of the first swivel lever 8. Now, by means of the drive motor 15, the crank 6 can be rotated together with the drive element 16 and the crank 6 can move the first swivel lever 8 with a set shed stroke causing a movement of the heald frame 2 over a set stroke.

[0048] In order to drive the drive motor 15 for setting or adjusting the shed stroke, a computer program comprising instructions is used, which computer program, when the program is executed by a computer, causes the computer to carry out the adjustment method as explained above. The computer program comprising in one embodiment instructions which, when the program is ex-

ecuted by the computer, cause the computer to determine a direction of rotation of the drive element 16 associated with an upward movement of a heald frame 2 coupled to the crank 6, in other words a movement of the heald frame 2 for moving the first swivel lever 8 away from the blocking element 27. This prevents that the shedding unit 1 could be damaged by driving the drive motor 15, in case the locking unit 30 would be not unlocked well.

[0049] Further the computer program in one embodiment comprises instructions which, when the program is executed by the computer, cause the computer to determine a reference angular position of the crank 6 with respect to the drive element 16 for setting a desired stroke of the heald frame 2 coupled to the crank 6. For example, a mutual angular position for a shed stroke defined by the circular trajectory 38 as shown in Fig. 7 or another mutual angular position for a shed stroke defined by the circular trajectory 38 as shown in Fig. 8, which will cause a stroke of the heald frame 2, which further depends on a coupling position of the first lifting rod 13 (see Fig. 1) on the first swivel lever 8. For moving the crank 6 with respect to drive element 16 into the determined reference angular position, in one embodiment a state of the driving device 5 is chosen, in which the swivel lever 8 makes contact with the blocking element 27. In this way, the movement of the distal end 24 of the crank 6 is constrained by the coupling rod 7 to a circular path having its center at the hinged joint 25. Hence, the orientation or the direction of the drive element 16 and, thus, the second eccentricity 36 as shown in Fig. 7, defines the reference angular position of a starting shed stroke shown in Fig. 7, and the orientation or the direction of the second eccentricity 36 as shown in Fig. 8 defines the reference angular position of a desired starting shed stroke shown in Fig. 8. The person skilled in the art will understand that the reference angular positions and the shed strokes shown in Figs. 7 and 8 are given only as examples.

[0050] For the control of the drive motor 15, the reference angular position can be stored, in other words a reference angular position is determined, in which the heald frame 2 coupled to the driving device 5 is in a defined position, namely the position in which the first swivel lever 8 can make contact with the blocking element 27. Thus, if the drive element 16 of the driving device 5 is in this defined position, the first swivel lever 8 and the heald frame 2 coupled to the first swivel lever 8 are in a defined position determined by the blocking element 27. In an alternative embodiment, if the blocking element 27 can make contact with the second swivel lever 10, as shown in Figs. 1 and 2, the reference angular position will be determined by the position where the second swivel lever 10 can make contact with the blocking element 27.

FURTHER EMBDIMENTS

[0051]

1. A driving device for a shedding unit (1), the driving device (5) comprising a rotationally mounted drive element (16), a crank (6), and a locking unit (30), wherein the drive element (16) has an axis of rotation (17), a first end (18), and a second end (19), wherein the first end (18) and the second end (19) are distanced from each other in the direction of the axis of rotation (17) of the drive element (16), wherein the drive element (16) is provided at the second end (19) with a seat (20), wherein the crank (6) is provided with a coupling element (21), which coupling element (21) cooperates with the seat (20) for mounting the crank (6) to the drive element (16) so as to be rotatable about a seat axis (22) of the seat (20), which seat axis (22) is parallel but offset to the axis of rotation (17) of the drive element (16), wherein for a rotation about the axis of rotation (17) of the drive element (16) together with the drive element (16), the crank(6) is releasably lockable to the drive element (16) in different angular positions with respect to the drive element (16) by the locking unit (30), wherein when the crank (6) is unlocked from the drive element (16), for adjusting the angular position of the crank (6) with respect to the drive element (16), the driving device (5) is configured to move the drive element (16) about the axis of rotation (17) of the drive element (16) for causing a relative movement between the drive element (16) and the crank (6) about the seat axis (22).

2. The driving device according to embodiment 1, wherein a drive motor (15) is provided, which drive motor (15) is configured to drive the drive element (16) so as to move about the axis of rotation (17) of the drive element (16).

3. The driving device embodiment to embodiment 1 or 2, wherein the locking unit (30) is accessible for a manual operation from a first end (18) of the drive element (16) for locking the crank (6) to the drive element (16) or for unlocking the crank (6) from the drive element (16).

4. The driving device according to any one of embodiments 1, 2 or 3, wherein the coupling element (21) and the seat (20) are arranged for locking the crank (6) to the drive element (16) by forcing the crank (6) and the drive element (16) towards each other in the direction of the seat axis (22), wherein the locking unit (30) is actuable for causing a movement of the crank (6) towards or away from the drive element (16) in the direction of the seat axis (22).

5. The driving device according to any one of embodiment 1 to 4, wherein one of the coupling element (21) and the seat (20) is a member in the form of a truncated cone and the other one is a complementary receiving bushing.

6. The driving device according to any one of embodiment 1 to 5, wherein the locking unit (30) comprises a locking pin (31), which locking pin (31) is moveably mounted to the drive element (16) and is moveable in one direction for locking the crank (6) to the drive element (16) and in an opposite direction for unlocking the crank (6) from the drive element (16), wherein in particular the locking pin (31) has an actuating end (32) configured to receive an actuating force for moving the locking pin (31) with respect to the drive element (16), which actuating end (32) is arranged at the first end (18) of the drive element (16).

7. The driving device according to embodiment 6, characterized in that the locking pin (31) is arranged in the drive element (16) so as to be rotatable about the seat axis (22), wherein the locking pin (31) is provided with an actuating end (32) configured to receive an actuating force for moving the locking pin (31) with respect to the drive element (16), and wherein the locking pin (31) is provided with a threaded end (33) opposite to the actuating end (32), which threaded end (33) cooperates with a threaded hole (34) of the crank (6) for causing a movement of the crank (6) towards or away from the drive element (16) in the direction of the seat axis (22) by rotating the locking pin (31) about the seat axis (22).

8. A weaving machine with a driving device according to any one of embodiments 1 to 7.

9. A method for adjusting a shed stroke of a driving device (5) for a shedding unit (1), the driving device (5) comprising a rotationally mounted drive element (16), a crank (6), and a locking unit (30), wherein the drive element (16) has an axis of rotation (17), a first end (18), and a second end (19), wherein the first end (18) and the second end (19) are distanced from each other in the direction of the axis of rotation (17) of the drive element (16), wherein the drive element (16) is provided at the second end (19) with a seat (20), wherein the crank (6) is provided with a coupling element (21), which coupling element (21) cooperates with the seat (20) for mounting the crank (6) to the drive element (16) so as to be rotatable about a seat axis (22) of the seat (20), which seat axis (22) extends parallel but offset to the axis of rotation (17) of the drive element (16), and wherein for a rotation about the axis of rotation (17) of the drive element (16) together with the drive element (16), the crank (6) is releasably lockable to the drive element (16) in different angular positions with respect to the drive element (16) by the locking unit (30), wherein when the crank (6) is unlocked from the drive element (16), for adjusting the angular position of the crank (6) with respect to the drive element (16), the drive element (16) is moved about the axis of rotation (17) of the

drive element (16) for causing a relative movement between the drive element (16) and the crank (6) about the seat axis (22).

10. The method according to embodiment 9, characterized in that the drive element (16) is driven to move about the axis of rotation (17) of the drive element (16) by a drive motor (15) when the crank (6) is unlocked from the drive element (16) for adjusting the angular position of the crank (6) with respect to the drive element (16).

11. The method according to embodiment 9 or 10, wherein a heald frame (2) coupled to the crank (6) is held in position while driving the drive element (16) so as to move about the axis of rotation (17) of the drive element (16) when the crank (6) is unlocked from the drive element (16) for restricting a movement of the distal end (24) of the crank (6).

12. The method according to embodiment 11, wherein for adjusting the angular position of the crank (6) with respect to the drive element (16), the drive element (16) is moved about the axis of rotation (17) of the drive element (16) in a direction associated with an upward movement of the heald frame (2) coupled to the crank (6).

13. A computer program comprising instructions which, when the program is executed by a computer, cause the computer to carry out the method of any one of embodiments 9 to 12.

14. The computer program according to embodiment 13, further comprising instructions which, when the program is executed by the computer, cause the computer to determine a direction of rotation of the drive element (16) associated with an upward movement of a heald frame (2) coupled to the crank (6).

15. The computer program according to embodiment 13 or 14, further comprising instructions which, when the program is executed by the computer, cause the computer to determine a reference angular position of the crank (6) with respect to the drive element (16) for setting a desired stroke of the heald frame (2) coupled to the crank (6).

Claims

1. A driving device for a shedding unit (1), the driving device (5) comprising a rotationally mounted drive element (16), a crank (6), and a locking unit (30), wherein the drive element (16) has an axis of rotation (17), a first end (18), and a second end (19), wherein the first end (18) and the second end (19) are distanced from each other in the direction of the axis of

rotation (17) of the drive element (16), wherein the drive element (16) is provided at the second end (19) with a seat (20), wherein the crank (6) is provided with a coupling element (21), which coupling element (21) cooperates with the seat (20) for mounting the crank (6) to the drive element (16) so as to be rotatable about a seat axis (22) of the seat (20), which seat axis (22) is parallel but offset to the axis of rotation (17) of the drive element (16), wherein for a rotation about the axis of rotation (17) of the drive element (16) together with the drive element (16), the crank (6) is releasably lockable to the drive element (16) in different angular positions with respect to the drive element (16) by the locking unit (30), **characterized in that** when the crank (6) is unlocked from the drive element (16), for adjusting the angular position of the crank (6) with respect to the drive element (16), the driving device (5) is configured to move the drive element (16) about the axis of rotation (17) of the drive element (16) for causing a relative movement between the drive element (16) and the crank (6) about the seat axis (22), wherein means are provided for restricting a movement of a distal end (24) of the crank (6) to movement along a defined path, when unlocking the crank (6) from the drive element (16) and moving the drive element (16) about the axis of rotation (17) of the drive element (16).

2. The driving device according to claim 1, **characterized in that** the driving device (5) further comprising a first swivel lever (8) having a first arm and a second arm, wherein the first swivel lever (8) is swivelable to-and-fro about a swivel axis (9) between a first position associated with an upper position of a heald frame (2) coupled to the first swivel lever (8) and a lower position associated with a lower position of the heald frame (2) coupled to the first swivel lever (8), a coupling rod (7), which is linked to the crank (6) by a first hinged joint, wherein the coupling rod (7) is linked to the first arm of the first swivel lever (8) by a second hinged joint (25), and a blocking element (27), wherein for adjusting the angular position of the crank (6) with respect to the drive element (16), the second hinged joint (25), the first swivel lever (8) and/or the heald frame (2) coupled to the driving device (5) is/are held in position by means of the blocking element (27) while moving the drive element (16) about the axis of rotation (17) of the drive element, thereby restricting the movement of the distal end (24) of the crank (6) to the defined path.
3. The driving device according to claim 1, **characterized in that** the driving device (5) further comprising a coupling rod (7) coupled to the distal end (24) of the crank (6), a first swivel lever (8), which first swivel lever (8) is linked to the coupling rod (7) and swivelable to-and-fro about a swivel axis (9) between an

upper position and a lower position, a connecting rod (11), and a second swivel lever (10), which second swivel lever (10) is swivelable to-and-fro about a swivel axis (12) between an upper position and a lower position, and is linked to the first swivel lever (8) by means of a connecting rod (11), wherein the means for restricting the movement of the distal end (24) of the crank (6) when unlocking the crank (6) from the drive element (16) is a blocking element (27), which blocking element (27) can be arranged in the range of one of the first swivel lever (8), the connecting rod (11), the second swivel lever (10), and a heald frame (2) coupled to the driving device (5) to hinder a movement of the first swivel lever (8), the connecting rod (11), the second swivel lever (10), and the heald frame (2), and can be displaced so that it does not hinder the movement of the first swivel lever (8), the connecting rod (11), the second swivel lever (10), and the heald frame (2).

4. The driving device according to claim 2 or 3, **characterized in that** the blocking element (27) is configured to be placed under the first swivel lever (8), when the heald frame (2) coupled to the first swivel lever (8) is in an upper position, and the heald frame (2) is adapted to be moved downwards until the first swivel lever (8) abuts against the blocking element (27).
5. The driving device according to any one of claims 1 to 4, **characterized in that** a drive motor (15) is provided, which drive motor (15) is configured to drive the drive element (16) so as to move about the axis of rotation (17) of the drive element (16).
6. A weaving machine with a driving device according to any one of claims 1 to 5.
7. A method for adjusting a shed stroke of a driving device (5) for a shedding unit (1), the driving device (5) comprising a rotationally mounted drive element (16), a crank (6), and a locking unit (30), wherein the drive element (16) has an axis of rotation (17), a first end (18), and a second end (19), wherein the first end (18) and the second end (19) are distanced from each other in the direction of the axis of rotation (17) of the drive element (16), wherein the drive element (16) is provided at the second end (19) with a seat (20), wherein the crank (6) is provided with a coupling element (21), which coupling element (21) cooperates with the seat (20) for mounting the crank (6) to the drive element (16) so as to be rotatable about a seat axis (22) of the seat (20), which seat axis (22) extends parallel but offset to the axis of rotation (17) of the drive element (16), and wherein for a rotation about the axis of rotation (17) of the drive element (16) together with the drive element (16), the crank (6) is releasably lockable to the drive element (16)

in different angular positions with respect to the drive element (16) by the locking unit (30), **characterized in that** when the crank (6) is unlocked from the drive element (16), for adjusting the angular position of the crank (6) with respect to the drive element (16), the drive element (16) is moved about the axis of rotation (17) of the drive element (16) for causing a relative movement between the drive element (16) and the crank (6) about the seat axis (22), wherein a movement of a distal end (24) of the crank (6) is restricted to a movement along a defined path, when unlocking the crank (6) from the drive element (16) and moving the drive element (16) about the axis of rotation (17) of the drive element (16).

8. The method according to claim 7, **characterized in that** the driving device (5) further comprising a first swivel lever (8) having a first arm and a second arm, wherein the first swivel lever (8) is swivelable to-and-fro about a swivel axis (9) between a first position associated with an upper position of a heald frame (2) coupled to the first swivel lever (8) and a lower position associated with a lower position of the heald frame (2) coupled to the first swivel lever (8), a coupling rod (7), which is linked to the crank (6) by a first hinged joint, wherein the coupling rod (7) is linked to the first arm of the first swivel lever (8) by a second hinged joint (25), and a blocking element (27), wherein for adjusting the angular position of the crank (6) with respect to the drive element (16), the second hinged joint (25), the first swivel lever (8) and/or the heald frame (2) coupled to the driving device (5) is/are held in position by means of the blocking element (27) while moving the drive element (16) about the axis of rotation (17) of the drive element, thereby restricting the movement of the distal end (24) of the crank (6) to a defined path.
9. The method according to claim 7, **characterized in that** the driving device (5) further comprising a coupling rod (7) coupled to the distal end (24) of the crank (6), a first swivel lever (8), which first swivel lever (8) is linked to the coupling rod (7) and swivelable to-and-fro about a swivel axis (9) between an upper position and a lower position, a connecting rod (11), and a second swivel lever (10), which second swivel lever (10) is swivelable to-and-fro about a swivel axis (12) between an upper position and a lower position, and is linked to the first swivel lever (8) by means of a connecting rod (11), wherein the means for restricting the movement of the distal end (24) of the crank (6) when unlocking the crank (6) from the drive element (16) is a blocking element (27), which blocking element (27) can be arranged in the range of one of the first swivel lever (8), the connecting rod (11), the second swivel lever (10), and a heald frame (2) coupled to the driving device (5) to hinder a movement of the first swivel lever (8),

the connecting rod (11), the second swivel lever (10), and the heald frame (2), and can be displaced so that it does not hinder the movement of the first swivel lever (8), the connecting rod (11), the second swivel lever (10), and the heald frame (2).

10. The method according to claim 8 or 9, **characterized in that** the heald frame (2) coupled to the first swivel lever (8) is moved to an upper position, the blocking element (27) is placed under the first swivel lever (8), and the heald frame (2) is moved downwards until the first swivel lever (8) abuts against the blocking element (27).
11. The method according to any one of claims 7 to 10, **characterized in that** the drive element (16) is driven to move about the axis of rotation (17) of the drive element (16) by a drive motor (15) when the crank (6) is unlocked from the drive element (16) for adjusting the angular position of the crank (6) with respect to the drive element (16).
12. The method according to any one of claims 7 to 11, **characterized in that** for adjusting the angular position of the crank (6) with respect to the drive element (16), the drive element (16) is moved about the axis of rotation (17) of the drive element (16) in a direction associated with an upward movement of a heald frame (2) coupled to the crank (6).
13. A computer program for use with the driving device (5) according to claim 5, the computer program comprising instructions which, when the program is executed by a computer, cause the computer to drive the drive motor (15) for adjusting a shed stroke of the driving device (5) when the crank (6) is unlocked from the drive element (16), wherein the drive element (16) is driven to move about the axis of rotation (17) of the drive element (16) by the drive motor (15) for causing a relative movement between the drive element (16) and the crank (6) about the seat axis (22).
14. The computer program according to claim 13, further comprising instructions which, when the program is executed by the computer, cause the computer to determine a stored reference angular position of the crank (6) with respect to the drive element (16) for setting a desired stroke of the heald frame (2) coupled to the crank (6).
15. The computer program according to claim 14, further comprising instructions which, when the program is executed by the computer, cause the computer to determine a necessary movement of the drive element (16) about the axis of rotation (17) for achieving a relative movement of the crank (6) with respect to the drive element (16) into said stored reference an-

gular position, when the movement of the distal end (24) of the crank (6) is restricted to the movement along the defined path when moving the drive element (16).

5

10

15

20

25

30

35

40

45

50

55

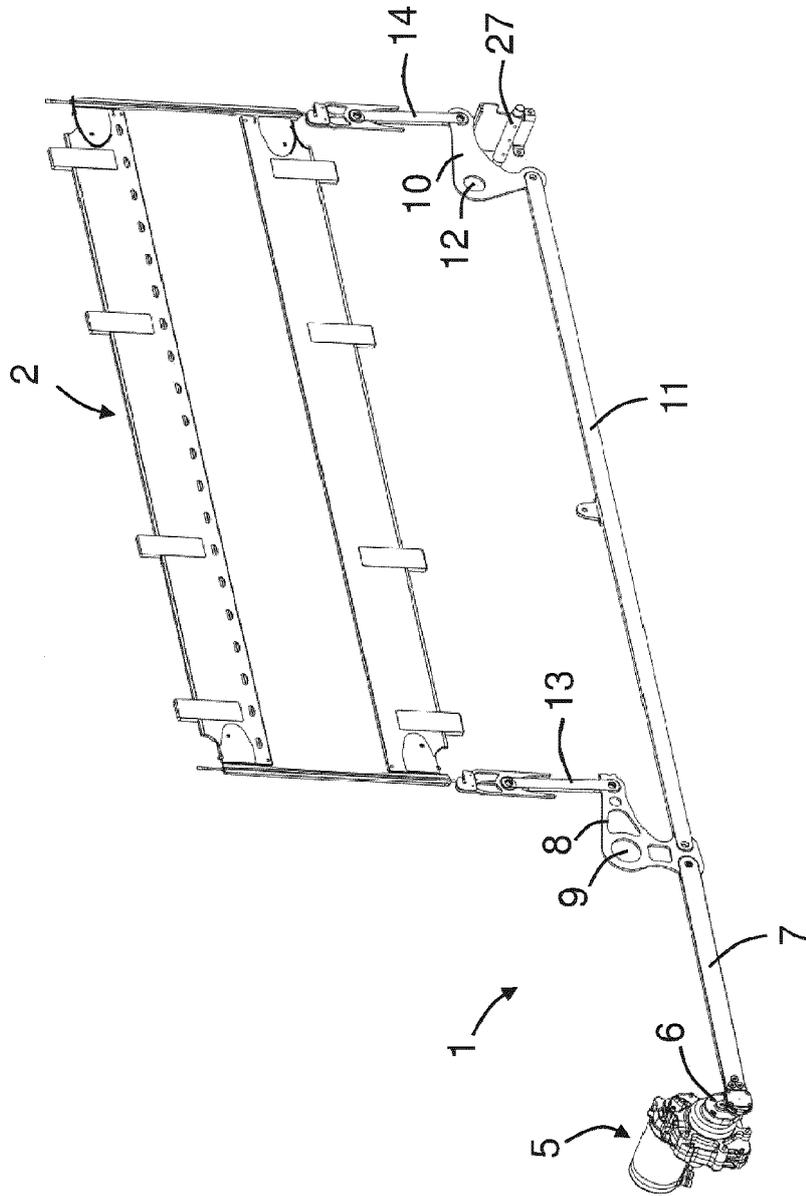

Fig. 1

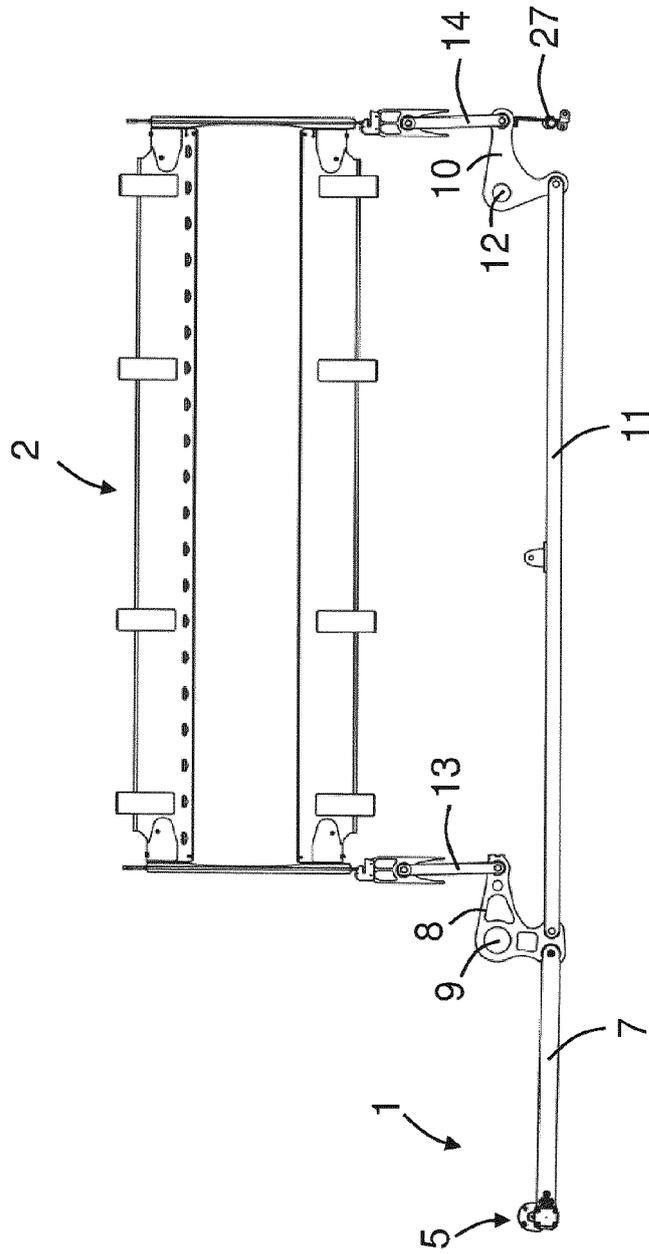

Fig. 2

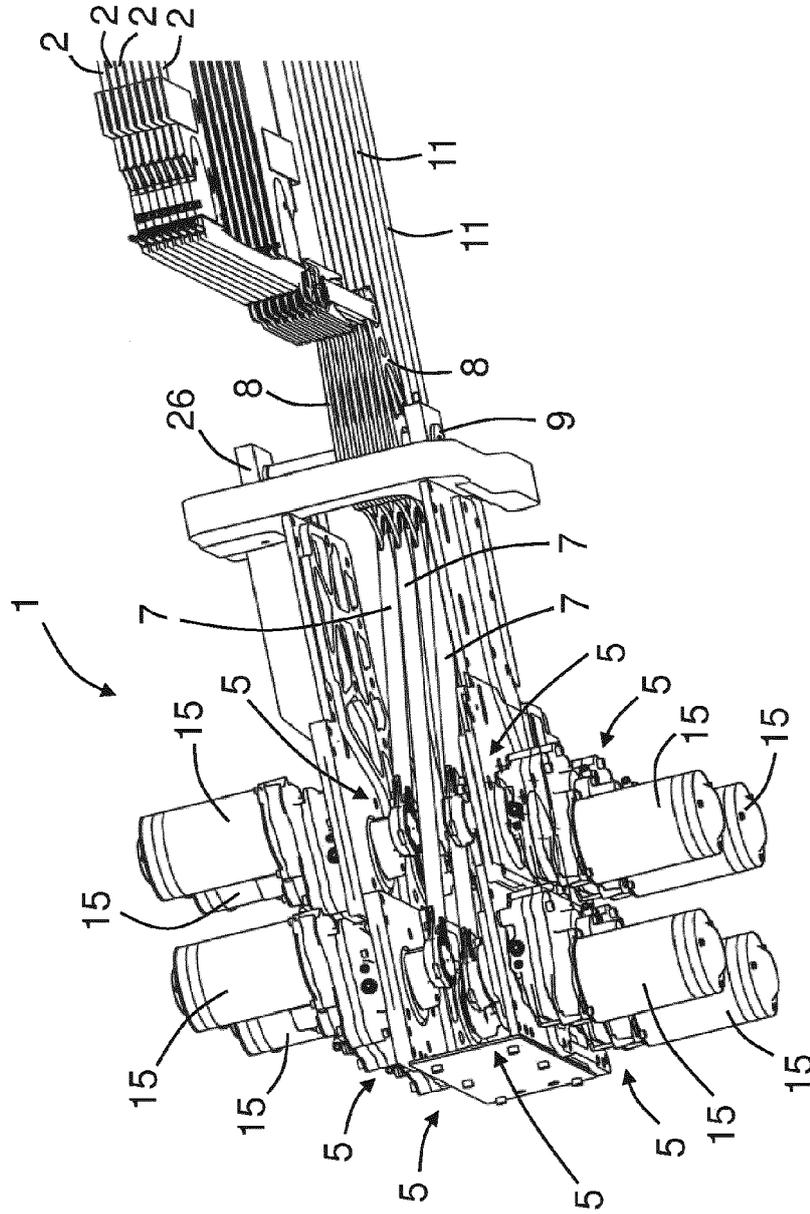

Fig. 3

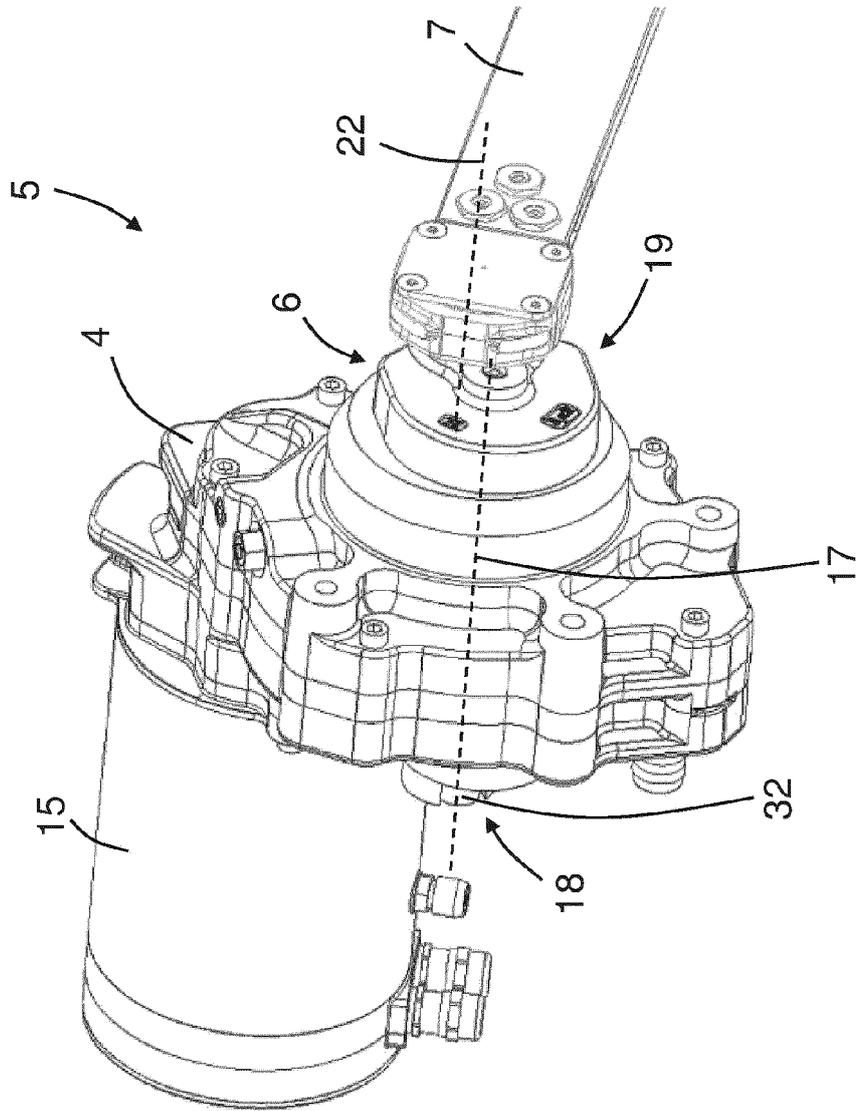

Fig. 4

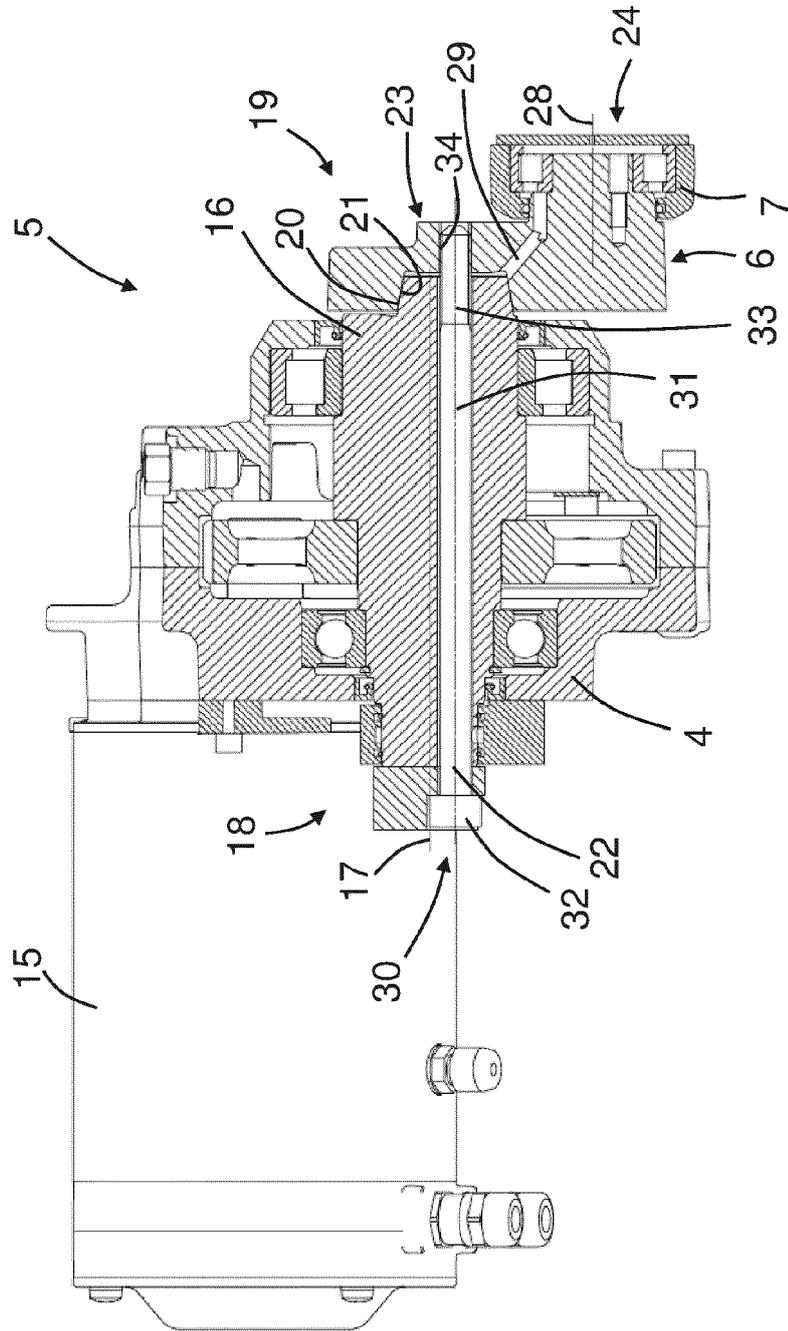

Fig. 5

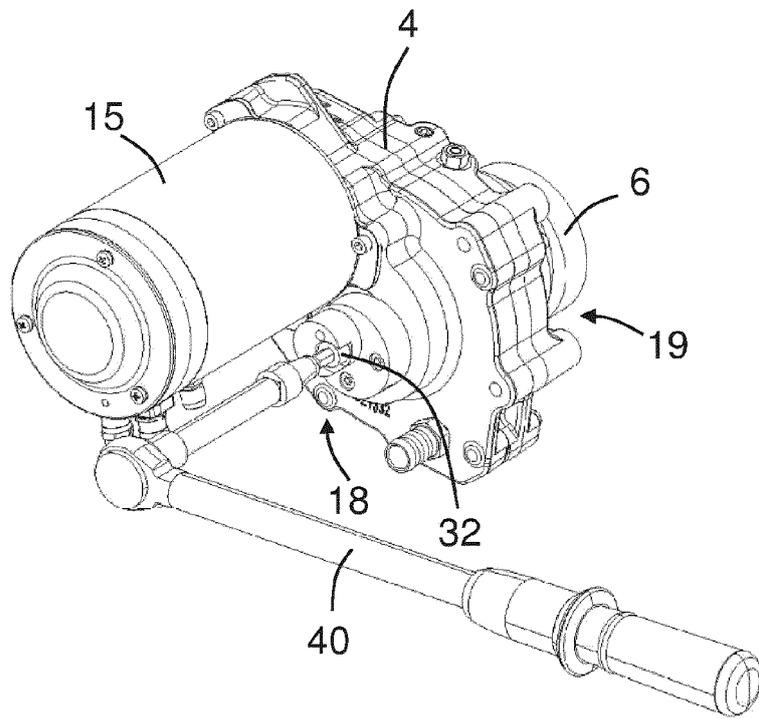

Fig. 6

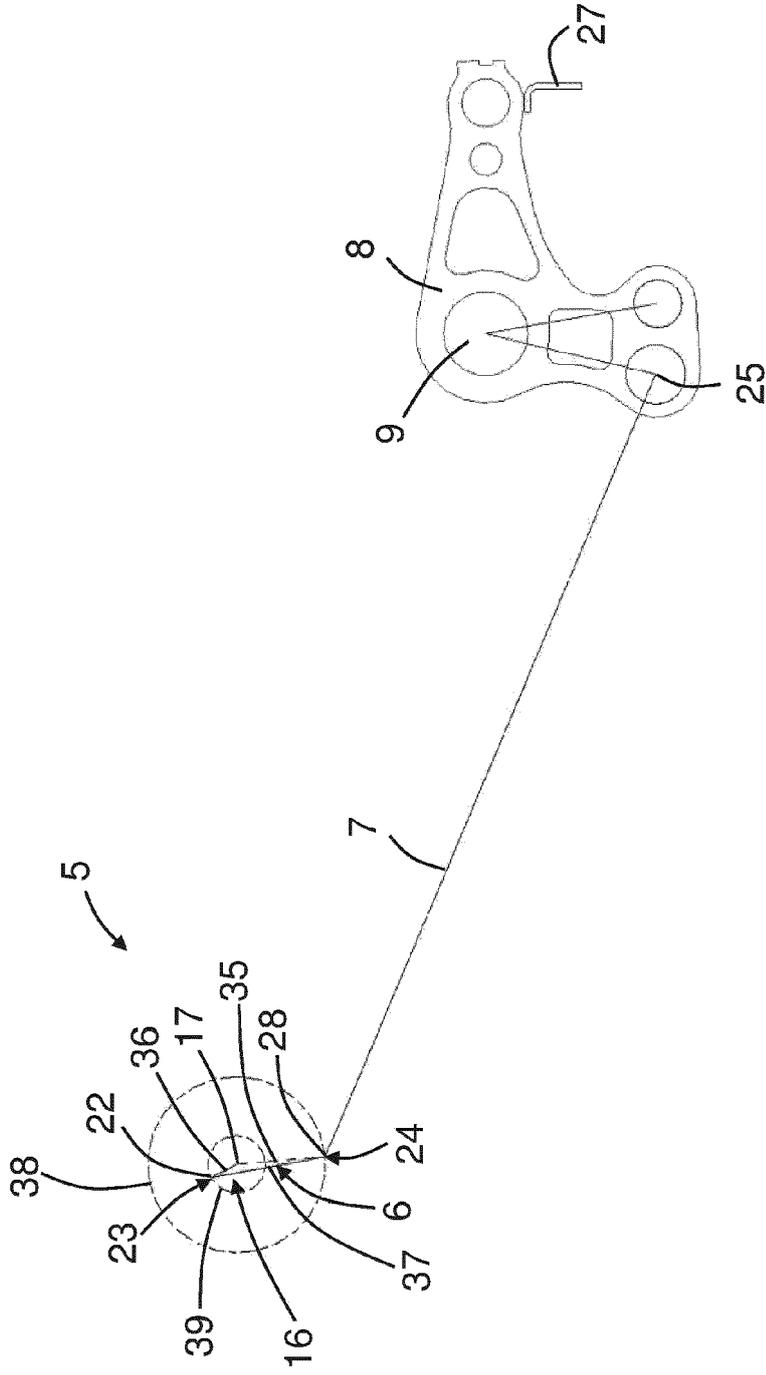

Fig. 7

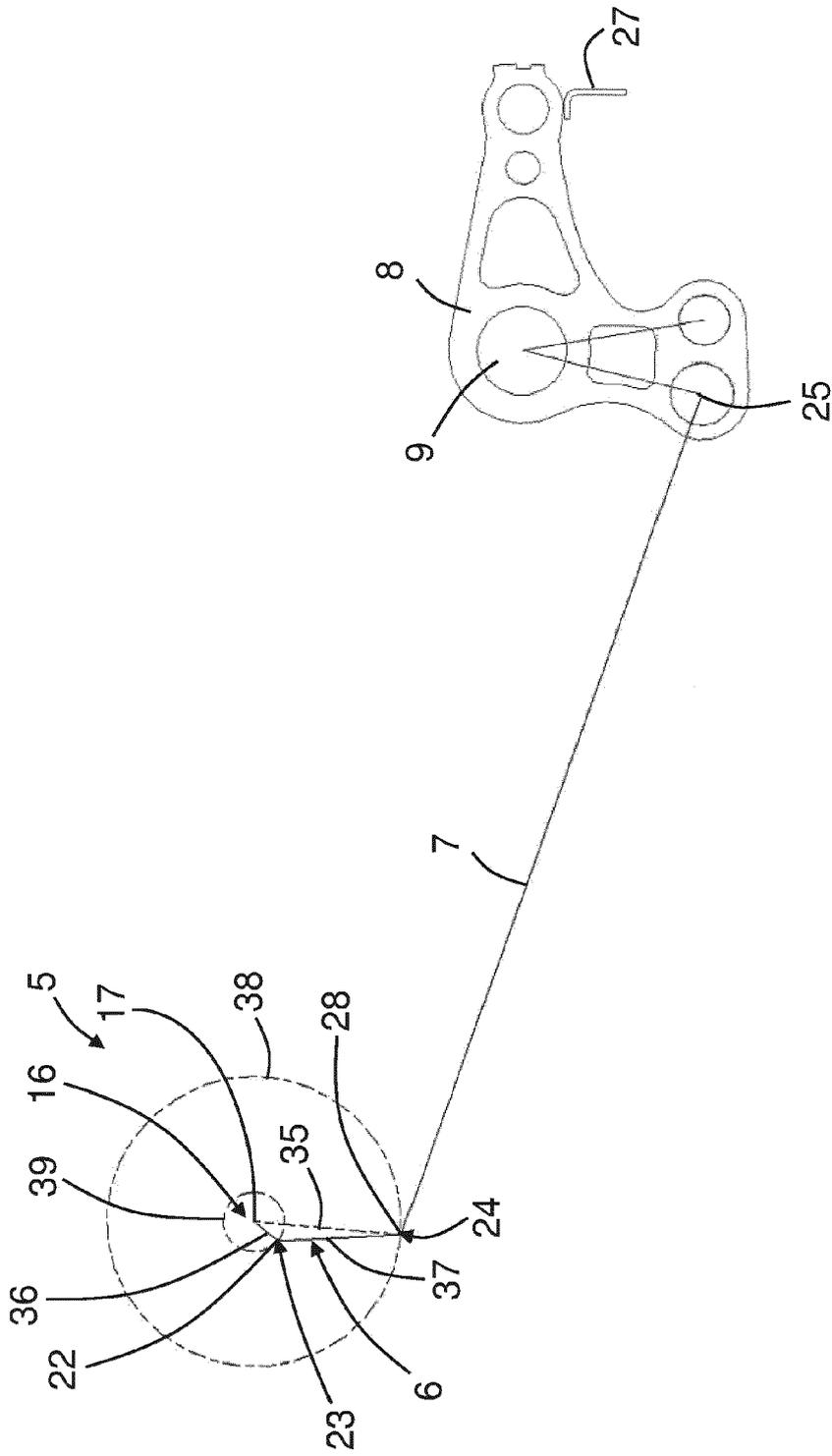

Fig. 8

REFERENCES CITED IN THE DESCRIPTION

This list of references cited by the applicant is for the reader's convenience only. It does not form part of the European patent document. Even though great care has been taken in compiling the references, errors or omissions cannot be excluded and the EPO disclaims all liability in this regard.

Patent documents cited in the description

- WO 2017032556 A1 [0003] [0032]
- JP H09112534 A [0004] [0009]
- WO 2004092465 A1 [0034]
- WO 2018007168 A1 [0041]