

(19)



(11)

**EP 4 269 880 A1**

(12)

**EUROPEAN PATENT APPLICATION**

(43) Date of publication:  
**01.11.2023 Bulletin 2023/44**

(51) International Patent Classification (IPC):  
**F24C 15/32<sup>(2006.01)</sup>**

(21) Application number: **22170737.5**

(52) Cooperative Patent Classification (CPC):  
**F24C 15/325; F24C 15/2007; F24C 15/327**

(22) Date of filing: **29.04.2022**

(84) Designated Contracting States:  
**AL AT BE BG CH CY CZ DE DK EE ES FI FR GB GR HR HU IE IS IT LI LT LU LV MC MK MT NL NO PL PT RO RS SE SI SK SM TR**  
Designated Extension States:  
**BA ME**  
Designated Validation States:  
**KH MA MD TN**

- **SOKOVETS, Dmytro**  
91541 Rothenburg ob der Tauber (DE)
- **FUNK, Greg**  
Springfield, 37172 (US)
- **BLANCHARD, Ryan**  
Charlotte, 28262 (US)
- **MACHOVSKA, Ilona**  
14021 Prague (CZ)
- **FLORES GALINDO, Diego**  
91451 Rothenburg ob der Tauber (DE)
- **BÖCKLER, Marco**  
91541 Rothenburg ob der Tauber (DE)

(71) Applicant: **ELECTROLUX APPLIANCES AKTIEBOLAG**  
105 45 Stockholm (SE)

(74) Representative: **Electrolux Group Patents**  
AB Electrolux  
Group Patents  
S:t Göransgatan 143  
105 45 Stockholm (SE)

(72) Inventors:  
• **SPECHT, Trevor**  
91541 Rothenburg ob der Tauber (DE)  
• **MÜNZ, Michael**  
91541 Rothenburg o. d. Tauber (DE)

(54) **DOMESTIC OVEN AND FAN IMPELLER FOR DOMESTIC OVEN**

(57) Domestic oven, comprising:  
- a cavity (10) defining a cooking chamber and having an front opening (22) that is closable by a door for charging and discharging food to be cooked into the cooking chamber;  
- at least one heating energy source for supplying heating energy to the cooking chamber;

- at least one air inlet (24) different from the front opening (22) that enables entering of ambient air into the cooking chamber;  
- at least one air outlet (26) different from the front opening (22) and from the air inlet (24) that enables air or an air-gas-mixture or an air-gas-steam mixture present in the cooking chamber to leave the cooking chamber.

FIG.4

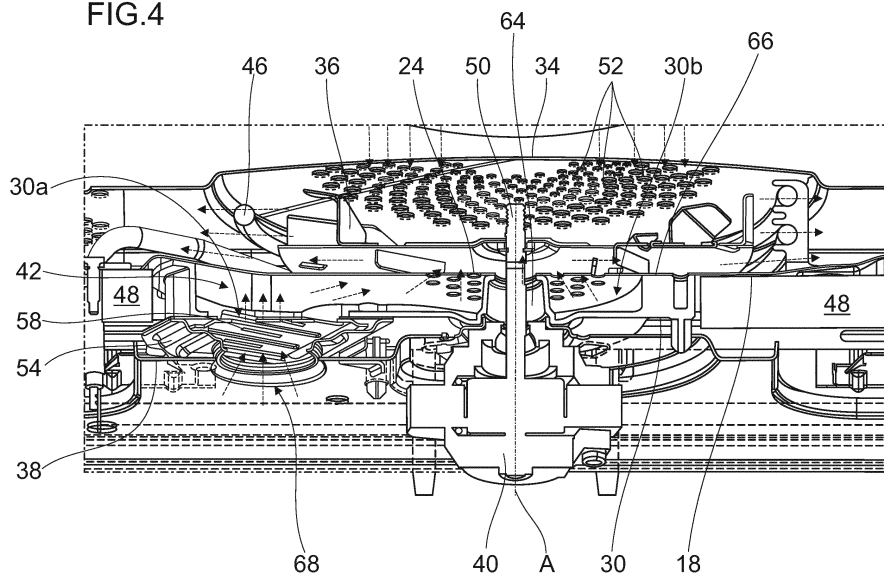

**EP 4 269 880 A1**

## Description

**[0001]** The present invention relates to a domestic oven and to a fan impeller for a domestic oven.

**[0002]** EP 3 029 382 A1 discloses a steam oven comprising a humidity flushing system. Such a steam oven comprises a cavity, wherein said cavity comprises at least one outlet opening for exhaustion of vapor and/or steam out of the cavity into a first duct, wherein said first duct can be opened or closed by a first valve, and at least one inlet opening for influx of air into the cavity from a second duct, wherein said second duct can be opened or closed by a second valve. Said outlet opening is positioned in an upper wall of said cavity. The first duct is arranged such that its first end is in fluid communication with the cavity at said outlet opening, and its second end is in fluid communication with a cooling system, more particularly a cooling chamber, whereas the second duct is arranged such that its first end is in fluid communication with the cavity at said inlet opening, and its second end is in fluid communication with said cooling system, more particularly the cooling chamber. More particularly, the second end of the first duct is arranged in an under pressure region of said cooling system.

**[0003]** The object of the present invention is to provide a domestic oven with improved ventilation properties and/or improved convection properties.

**[0004]** This object is solved by a domestic oven according to a first aspect of the invention that is reflected in claim 1. A domestic oven according to the invention comprises:

- a cavity defining a cooking chamber and having an front opening that is closable by a door for charging and discharging food to be cooked into the cooking chamber;
- at least one heating energy source for supplying heating energy to the cooking chamber;
- at least one air inlet different from the front opening that enables entering of ambient air into the cooking chamber;
- at least one air outlet different from the front opening and from the air inlet that enables air or an air-gas-mixture or an air-gas-steam mixture present in the cooking chamber to leave the cooking chamber.

**[0005]** In a domestic oven according to the invention ambient air is enabled to enter the cooking chamber and not air that has been subject to a cooling system. Thus, a simplified ventilation system of the oven with increased efficiency is achieved. Such a efficient ventilation system is particularly advantageous when operated within a domestic steam oven. Thus, a destemming process step for destemming the cavity of the domestic oven can be accelerated.

**[0006]** According to an advantageous embodiment the air inlet comprises one hole or a plurality of holes, in particular formed in a regular pattern, that is/are arranged,

in particular concentrically, around an opening in a cavity wall, in particular a cavity rear wall, for receiving a drive shaft for driving a fan impeller arrangeable or arranged inside of the cavity, and/or

5 in that the air outlet comprises one hole or a plurality of holes, in particular formed in a regular pattern, that is/are arranged in a cavity wall, in particular in a top wall, adjacent to a front end of the cavity, in particular adjacent to the front opening.

10 **[0007]** A plurality of holes formed in a pattern around a hole for receiving a drive shaft enables to suck in ambient air by a fan impeller attached to the drive shaft through the plurality of holes from outside of the cavity into the cavity. A plurality of holes in a regular pattern in  
15 general allows to form an air inlet or air outlet that is adapted in its form to the form of a duct element attached thereto.

**[0008]** According to a further advantageous embodiment, the domestic oven comprises an air inlet duct element that is attached to an exterior side of a cavity wall, in particular a cavity rear wall, in which the one hole or the plurality of holes of the air inlet is/are provided, where-  
20 in the air inlet duct element forms an air inlet duct for guiding ambient air to the one hole or the plurality of holes of the air inlet,  
25 and/or

in that the domestic oven comprises an air outlet duct element that is attached to an exterior surface of a cavity wall, in particular a cavity top wall, in which the one hole or the plurality of holes of the air outlet is/are provided, wherein the air outlet duct element forms an air outlet duct for guiding an air-gas-mixture or an air-gas-steam mixture leaving the one hole or the plurality of holes of the air outlet away from the cavity wall.

30 **[0009]** By providing an air inlet duct element, it is possible to guide ambient air from a desired position towards the holes of the air inlet. E.g. it is possible to pass ambient air through an insulation layer of the domestic oven towards the air inlet. An air outlet duct element enables to  
35 guide air-gas-mixture or an air-gas-steam mixture generated within the cavity towards a desired position distant from the cavity wall.

**[0010]** Further advantageously, the size of a passage formed by the air inlet is controllable, in particular in that the domestic oven comprises an air inlet valve for partially  
40 and/or fully opening and/or for partially and/or fully closing the passage formed by the air inlet duct and/or formed by the one hole or plurality of holes of the air inlet,  
45 and/or

in that the size of a passage formed by the air outlet is controllable, in particular in that the domestic oven comprises an air outlet valve for partially and/or fully opening  
50 and/or for partially and/or fully closing the passage formed by the air outlet duct and/or formed by the one hole or plurality of holes of the air outlet.

**[0011]** In this way, the amount or volume of ambient air entering the cavity per time unit is controllable and thus the atmosphere within the cavity can be controlled

according to the requirements of a desired cooking process or according to a desired oven function. In the case that the amount or volume of air-gas-mixture or air-gas-steam mixture leaving the cavity per time unit is controlled, the atmosphere can be controlled according to the requirements of a desired cooking process or according to a desired oven function.

**[0012]** Additionally, it may be advantageous, when the air inlet valve comprises a first valve element that is configured to partially and/or fully open and/or to partially and/or fully close the passage formed by the air inlet duct, in particular wherein the air inlet valve comprises an air inlet duct element that is attached to an exterior side of a cavity wall in which the air inlet is provided, such that the air inlet forms an outlet of the air duct,

and/or in that the air outlet valve comprises a second valve element that is configured to partially and/or fully open and/or to partially and/or fully close the passage formed by the air outlet duct, in particular wherein the air outlet valve comprises an air outlet duct element that is attached to an exterior side of a cavity wall in which the air outlet is provided, such that the air outlet forms an inlet of the air duct.

**[0013]** It may be advantageous for a domestic oven comprising a microwave function as the main heating function to be provided with an air inlet duct and/or and air outlet duct, but without an air inlet valve and/or an air outlet valve. The air inlet duct and the air outlet duct may contribute to leakage prevention of microwave radiation.

**[0014]** It may be advantageous for a domestic oven comprising a steam cooking function and/or conventional convection and/or upper and/or lower heating function and/or with a pyrolytic cleaning function to have an air outlet duct element with an air outlet valve. E.g. in a pre-heating phase or during a pyrolytic heating function the air outlet valve can be fully closed in order to prevent energy losses.

**[0015]** Advantageously, the domestic oven may be configured to have the air outlet valve closed, but slightly open or with a passage of small cross-section, such that generation of an overpressure within the cavity is avoided.

**[0016]** It may be advantageous for a domestic oven comprising a steam cooking function and a microwave function and optionally further heating function and/or oven function such as a pyrolytic cleaning function to have an air inlet duct element with an air inlet valve and an air outlet duct element with an air outlet valve, so that the air inlet and the air inlet and the air outlet can be fully controlled.

**[0017]** It is particularly advantageous for a domestic oven comprising a microwave function or a drying function or any other function that requires an efficient moist air removal, if the air inlet valve and the air outlet valve are fully open at the same time during the microwave function or the drying function or the other function requiring efficient moist air removal. This reduces conden-

sation inside the cavity and in an inner glass panel of an oven door for opening and closing the discharge opening and enables efficient drying of food within the cavity. Alternatively or additionally, it is advantageous for a domestic oven comprising a steam cooking, if the air outlet valve is slightly open, e.g. between 5% to 40 %, preferably between 10% and 30%, wherein the air inlet valve is fully closed at the same time. Thus, heat and steam are kept within the cavity, increasing energy efficiency and improving the cooking result, wherein at the same time occurrence of steam overpressure within the cavity is avoided which would cause steam to leak through the discharge opening, in particular through gaps between the door and the surrounding oven flange or surrounding oven structure. At the end of the steam cooking cycle, air inlet valve and air outlet valve may be opened fully in order to perform efficient destemming of the cavity. Such a destemming step allows to avoid large volumes of steam to come out of the cavity when the oven door is opened by a user. Further alternatively or additionally, during cooking function of the domestic oven using convection heating and/or grill heating and/or upper and/or lower heating elements, i.e. hot air heating, the air inlet valve and the air outlet valve may be opened periodically for a short time, e.g. less than 15s or less than 30s or less than 60s. This may be beneficial for energy efficiency and cooking performance.

**[0018]** It is also advantageous if the air inlet duct element forms a shaft passage for the drive shaft of a fan impeller arrangeable or arranged inside of the cavity that allows the drive shaft to extend straight through the passage of the air inlet duct element and through the opening in the cavity wall, in particular the cavity rear wall, for receiving the drive shaft and wherein the air inlet duct element forms the air inlet duct passing from a first air inlet duct opening being vertically and/or horizontally offset from the shaft passage to a second air inlet duct opening being arranged around the shaft passage and being connected in flow communication with the holes forming the air inlet around the opening for receiving the drive shaft in the cavity rear wall.

**[0019]** In this way, it is possible to guide ambient air from outside of the cavity from a position offset to the drive shaft to a position surrounding the drive shaft. This results in ambient air entering the cavity through holes surrounding the drive shaft. The fan impeller attached to the drive shaft is thereby enabled to efficiently suck ambient air through the holes surrounding the drive shaft into the cavity.

**[0020]** According to a further advantageous embodiment, the domestic oven comprises at least one microwave heating source and/or at least one steam heating source and/or at least one radiation heating source and comprising at least one controllable air inlet and at least one controllable air outlet, wherein the domestic oven is configured to substantially close the controllable air inlet and to partially, preferably slightly, open the controllable air outlet while the domestic

oven carries out a function to generate steam and/or to supply steam to the cooking chamber in order to perform a steam cooking process within the cooking chamber.

**[0021]** Additionally or alternatively, the domestic oven is configured to substantially fully open the controllable air inlet and to substantially fully open the controllable air outlet while the domestic oven carries out a function to remove steam that has been generated and/or supplied to the cooking chamber in order to perform a steam cooking process within the cooking chamber,

**[0022]** Additionally or alternatively, the domestic oven is configured to fully open the controllable air inlet and to fully open the controllable air outlet while the domestic oven removes moist air that is or has been generated while the domestic oven performs a microwave cooking process,

**[0023]** Additionally or alternatively, the domestic oven is configured to fully open the controllable air inlet and to fully open the controllable air outlet while the domestic oven removes moist air that is or has been generated while the domestic oven performs a drying process using the microwave heating source and/or the radiation heating source,

**[0024]** Additionally or alternatively, the domestic oven is configured to periodically open and close the controllable air inlet and/or the controllable air outlet while the domestic oven performs a cooking process using the radiation heating source.

**[0025]** A domestic oven can include one or more or all of the above described configurations. During a microwave function or a drying function or any other function that requires an efficient moist air removal, the air inlet valve and the air outlet valve may be fully open at the same time during the microwave function or the drying function or the other function requiring efficient moist air removal. This reduces condensation inside the cavity and in an inner glass panel of an oven door for opening and closing the discharge opening and enables efficient drying of food within the cavity. Alternatively or additionally, it is advantageous for a domestic oven comprising a steam cooking, if the air outlet valve is slightly open, e.g. between 5% to 40 %, preferably between 10% and 30%, wherein the air inlet valve is fully closed at the same time. Thus, heat and steam are kept within the cavity, increasing energy efficiency and improving the cooking result, wherein at the same time occurrence of steam overpressure within the cavity is avoided which would cause steam to leak through the discharge opening, in particular through gaps between the door and the surrounding oven flange or surrounding oven structure. At the end of the steam cooking cycle, air inlet valve and air outlet valve may be opened fully in order to perform efficient destemming of the cavity. Such a destemming step allows to avoid large volumes of steam to come out of the cavity when the oven door is opened by a user. Further alternatively or additionally, during cooking function of the domestic oven using convection heating and/or grill heating and/or upper and/or lower heating elements,

i.e. hot air heating, the air inlet valve and the air outlet valve may be opened periodically for a short time, e.g. less than 15s or less than 30s or less than 60s. This may be beneficial for energy efficiency and cooking performance.

**[0026]** In another advantageous embodiment, the domestic oven comprises a convection fan including a fan impeller being arranged within the cavity at a cavity wall, in particular at a rear wall of the cavity, adjacent to the at least one air inlet, wherein the convection fan is configured to draw ambient through the at least one air inlet into the cavity.

**[0027]** Such a fan impeller arrangement is specifically advantageous, because the fan impeller can efficiently suck air into the cavity and convey the air inside the cavity. Preferably, the holes of the air inlet are concentrically arranged around the drive shaft of the fan impeller.

**[0028]** Further advantageously, the fan impeller includes an impeller body that comprises a first type of impeller blades on an impeller side facing the cooking chamber and a second type of impeller blades different from the first type on an impeller side facing the cavity wall, in particular wherein the second type of impeller blades is configured to draw ambient air through the at least one air inlet into the cavity.

**[0029]** Thus, the size of the fan impeller can be reduced and the first and second types of impeller blades can be adopted to their respective functions.

**[0030]** It may further be advantageous, if the cavity wall, in particular the cavity rear wall, at which the fan impeller is arranged comprises an embossment extending towards the exterior side of the cavity and forming a clearance space on the interior side of the cavity,

in particular wherein the clearance space has such a shape that the second type of impeller blades can be arranged within the space or adjacent thereto and at a close distance to the cavity wall, preferably in that a slight underpressure can be or is generated within the clearance space by the rotating fan impeller and/or

in particular wherein the embossment has such a shape that it prevents or hinders the drawn in ambient air to flow in a vertical direction and and/or that it guides the drawn in ambient air in a lateral direction.

**[0031]** An embossment in the cavity wall that is adopted to the dimensions of the second type of impeller blades allows to create an air volume between the fan impeller and the cavity wall, thus, increasing the efficiency of drawing in air through the air inlet. Further, the embossment may be formed in a way that the ambient air sucked in through the air inlet is restricted from flowing in a vertical direction and is guided in a horizontal direction towards convection chamber outlets formed by the fan cover or between fan cover and cavity wall.

**[0032]** Alternatively or additionally advantageously,

the domestic oven may comprise a fan cover within the cavity separating a convection chamber from the cooking chamber, wherein the fan impeller is arranged within the convection chamber, in particular wherein the fan cover comprises central openings for allowing air to be drawn from the cooking chamber into the convection chamber by the fan impeller and wherein the fan cover delimits or forms lateral and/or upper and/or lower openings for allowing air to be exhausted from the convection chamber into the cooking chamber by the fan impeller.

**[0033]** In that way a very efficient convection heating function is created within the domestic oven, by defining openings in the fan cover to direct the air to be conveyed by the fan impeller into the cooking chamber.

**[0034]** Further advantageously, the fan impeller may be configured to generate or generates a convection air flow within the cavity and is configured to draw or draws in ambient air through the at least one air inlet and is configured to mix or mixes the drawn in ambient air into the convection air flow.

**[0035]** In that way ambient way can be mixed directly into the air-gas-mixture or air-gas-steam mixture present in the cavity, thereby enabling control of the atmosphere within the cavity.

**[0036]** Also advantageous it is if the air inlet duct element is embedded within insulation surrounding the cavity, such that ambient air from a region distant from the cavity can pass the air inlet duct element and enter into the cooking chamber through the air inlet duct element.

**[0037]** The inlet duct element prevents insulation fibres from being sucked into the cavity. Further, the inlet duct guides ambient air from a position where no insulation is present through the insulation to the air inlet.

**[0038]** Further, it is advantageous if a drive unit support for supporting a drive unit for driving the convection fan is provided, wherein the drive unit support may be arranged outside of the cavity at a distance to the cavity rear wall, wherein a drive unit support opening may be provided within the drive unit support and wherein the air inlet duct element may fluidically couple the drive unit support opening with the air inlet, in particular wherein the drive unit support opening may be arranged horizontally and/or vertically offset from the opening for receiving the drive shaft.

**[0039]** In this way a passage or conduit from the drive unit support to the air inlet is created that allows air to be guided from a side of the drive unit support averted from the cavity to the air inlet.

**[0040]** Another object of the invention is to provide a fan that allows improved ventilation properties and/or improved convection properties within a domestic oven cavity.

**[0041]** As a second aspect of the invention, this object is solved by a fan impeller defining an axis A of rotation and comprising a backing plate and at least two or three or a plurality of fan blades being attached to the backing plate, wherein the backing plate is formed as a substantially flat circular disc and wherein at least one or at least

two or all of the fan blades comprise a first blade portion extending substantially from the backing plate and a second blade portion extending as a free end of the fan blade(s) from the first blade portion in an angle  $\alpha$  such that the second blade portion extends non-parallel to a plane being drawn up perpendicular to the axis A of rotation.

**[0042]** The second blade portion may be bent or folded from the first blade portion. Further, the free end of the fan blades(s) may point in the direction of rotation, or in other words define the preferred direction of rotation, of the fan impeller. Such a fan impeller is able to properly distribute radially an air flow through passages formed between the separate blades, thus, increasing efficiency of air distribution and performance. The second blade portion according to the invention channels air along the blades during fan impeller rotation.

**[0043]** According to an advantageous embodiment, the first blade portion and/or the second blade portion are planar and flat portions of the fan blades and wherein the angle  $\alpha$  between the first blade portion and the second blade portion is in the range between  $93^\circ$  and  $120^\circ$ , in particular between  $95^\circ$  and  $110^\circ$ , preferably is  $100^\circ$ .

**[0044]** Such a fan impeller has been found to be highly efficient.

**[0045]** According to a further advantageous embodiment, each first blade portion defines an radially outermost tip of the fan blade to which it belongs, wherein the outermost tip defines a circle upon rotation of the fan impeller, wherein a tangent to the circle and touching the outermost tip encloses an angle  $\beta$  with a main surface of the first blade portion that is directed radially outwards, wherein the angle  $\beta$  is in the range between  $85^\circ$  and  $45^\circ$ , in particular between  $70^\circ$  and  $50^\circ$ , preferably is  $60^\circ$ .

**[0046]** A main surface of the first blade portion oriented in this way contributes very efficiently to the radial push of air.

**[0047]** In an alternative or additional advantageous embodiment, the fan impeller comprises main fan blades comprising the first and second blade portions and supplementary fan blades, wherein the supplementary fan blades are arranged on the side of the fan impeller that is opposite to the side of the fan impeller on which the main fan blades are arranged, wherein the supplementary fan blades are planar and flat fan blades and wherein the first blade portion of the main fan blades and the supplementary fan blades extend substantially the direction of rotation (R) of the fan impeller, and wherein the main surfaces first blade portions and the main surfaces of the supplementary fan blades are arranged non-parallel to each other.

**[0048]** For such a fan impeller the interaction between suction side with the supplemental blades and pressure side with the main blades is minimized. Advantageously, the backing plate may prevent air on the pressure side to reach the suction side of the fan impeller.

**[0049]** It is particularly advantageous, if a fan impeller according to the invention is used in a domestic oven

according to the invention.

**[0050]** Alternatively or additionally advantageous it is, if the main fan blades and in particular also the supplementary fan blades are formed to a blade element, wherein the blade element may be attached to a backing plate, in particular by a clamp connection or a clinch connection or snap connection. Alternatively, it is also possible that the supplementary fan blades are formed to the backing plate.

**[0051]** Further advantageously, the backing plate may be formed as a circular and substantially flat disc having a diameter that is substantially equal to the diameter of the substantially wheel-shaped blade element.

**[0052]** Furthermore, it may be advantageous, that the supplementary fan blades are planar and flat fan blades, wherein a main surface of the supplementary fan blade that is arranged radially outward and encloses an angle  $\gamma$  with the tangent, wherein the angle  $\gamma$  is in the range between  $85^\circ$  and  $45^\circ$ , in particular between  $70^\circ$  and  $50^\circ$ , preferably is  $60^\circ$ . Alternatively or additionally, the main surface of a supplementary fan blade can be parallel to a main surface of an adjacent main fan blade or the main surface of a supplementary fan blade can be arranged in an angle in a range between  $-15^\circ$  to  $15^\circ$  to a main surface of an adjacent main fan blade.

**[0053]** Thus, the main fan blades are adapted to be highly efficient in pushing air, wherein the supplemental fan blades are adapted to be highly efficient in drawing air, e.g. through the air inlet in the cavity wall into the cavity.

**[0054]** Furthermore, the backing plate and/or the blade element may comprise a hub in which a recess is arranged for receiving a drive shaft operable connected to a drive unit for driving the fan impeller.

**[0055]** It is particular advantageous to use a fan impeller according to the second aspect of the invention in a domestic oven according to the first aspect of the invention.

**[0056]** The invention will be explained in further detail with reference to the accompanying drawings, in which:

Fig. 1 illustrates a perspective view of a cavity of a domestic oven according to a first aspect of the invention;

Fig. 2A illustrates a perspective view of a cavity of a domestic oven according to the invention with additional components attached to the air inlet and air outlet;

Fig. 2B illustrates a perspective view of an air outlet duct element and an air outlet valve;

Fig. 2C illustrates a perspective view of an air outlet duct element with the air outlet valve being removed;

Fig. 2D illustrates a perspective view of air inlet duct element and an air inlet valve;

Fig. 2E illustrates a perspective view of air inlet duct element with the air outlet valve being removed;

Fig. 3 illustrates a sectional view of the cavity rear wall seen from a point of view at the left side of the cavity shown in Fig. 2A with additional components attached to the cavity rear wall;

Fig. 4 illustrates a sectional view of the cavity rear wall seen from a point of view at the top of the cavity shown in Fig. 2A with additional components attached to the cavity rear wall;

Fig. 5 illustrates a rear view of the cavity rear wall as shown in Fig. 3 and Fig. 4;

Fig. 6 illustrates perspective view of a front side of a fan impeller according to a second aspect of the invention;

Fig. 7 illustrates perspective view a rear side of the fan impeller as shown in Fig. 6;

Fig. 8 illustrates side view of a main fan blade on a fan impeller as shown in Fig. 6 and Fig. 7;

**[0057]** Fig. 1 illustrates a cavity 10 of a domestic oven. The cavity 10 comprises a top wall 12, side walls 14, 16, a rear wall 18 and a bottom wall 20. The cavity 10 defines a cooking chamber enclosed by the walls 12 to 20 and by a door for selectively opening and closing a discharge opening of the cavity 10. In the shown embodiment, a front opening 22 forms the discharge opening.

**[0058]** In a central part of the rear wall 18, an air inlet 24 is provided for allowing air to enter the cavity 10. Air may be actively sucked in or pushed through the air inlet 24, by an appropriate ventilation system or it may be sucked in due to an underpressure generated in the cooking chamber.

**[0059]** The air inlet 24 is provided with a plurality of holes arranged in a regular pattern in the central part of the rear wall 18. The plurality of holes is arranged around an opening 28 for receiving a drive shaft 50 (not shown in Fig. 1, but in Figs. 3 and 4).

**[0060]** The air inlet 24 and opening 28 are arranged within a portion of the rear wall 18 embossed towards the exterior side of the cavity 10, thus, forming an embossment 66.

**[0061]** In a region of the top wall 12, an air outlet 26 is arranged that is located adjacent to a front end of the cavity 10 and adjacent to the right (if shown from a rear perspective) side wall 16. Also the air outlet 26 is provided as a plurality of holes arranged in a regular pattern. Also the air outlet 26 is arranged in a section of the top wall 12 that is embossed towards the exterior side of the cavity, thus, forming an air outlet embossment.

**[0062]** Fig. 2a illustrates the cavity 10 as shown in Fig. 1, wherein additionally an air inlet duct element 30 and

an air inlet valve 54, as well as an air outlet duct element 32 and an air outlet valve 56 are attached to the cavity 10. Details of air inlet duct element 3, air inlet valve 54, air outlet duct element 32 and an air outlet valve 56 are shown Fig. 2b to 2e and in Fig. 3 and 4.

**[0063]** The air inlet duct element 30 comprises a duct body forming an air inlet duct 42 extending from a first air inlet duct opening 30a to a second air inlet duct opening 30b (shown in Fig. 4). The air inlet duct element 30 is attached to the outside of the cavity rear wall 18 such that the second inlet duct opening 30b is matchingly arranged on the plurality of holes forming the air inlet 24. The first opening 30a is located laterally and/or vertically offset from the second opening 30b, so that the air inlet duct element 30 forms the passage for air to pass from a position offset to the centrally arranged plurality holes of the air inlet 24 towards the centrally arranged plurality holes of the air inlet 24. In this way, ambient air can be guided to the centrally arranged air inlet 24.

**[0064]** The air inlet duct element 30 is screwed or otherwise attached to the cavity 10. The first inlet duct opening 30a can be opened and closed by means of the air inlet valve 54. More specifically, the opening 30a can be selectively opened and closed in an infinite way by the first valve element 58. For this purpose, the air inlet valve 54 may comprise a first valve element 58 which can be driven by a valve drive to selectively close, partially close or let the opening 30a fully open. The air inlet valve 54 is fixed to the air inlet duct element 30.

**[0065]** The air outlet duct element 32 may be screwed or otherwise connected to the cavity 10. The air outlet duct element 32 has an air outlet duct opening 70 and forms a duct or passage from the air outlet 26 to the air outlet duct opening 70. A second valve element 56 is fixed to the air outlet duct element 32 such that the air outlet duct opening 70 can be selectively opened and closed in an infinite way by the second valve element 60. For this purpose, the air outlet valve 56 may comprise a second valve element 60 which can be driven by a valve drive to selectively close, partially close or let the air outlet duct element 70 fully open. The air outlet valve 56 is fixed to the air duct element 32 as illustrated in Fig. 3 and 4.

**[0066]** Further, a fan cover 34 is provided inside of the cavity 10 to delimit a convection chamber from the cooking chamber. The fan cover 34 is arranged adjacent to the cavity rear wall 18, wherein a ring-shaped heating element 46 and a fan impeller 36 are arranged within the convection chamber.

**[0067]** The fan impeller 36 is attached to a drive shaft 50 operably coupled to a drive unit 40 located outside of the cavity 10. The drive shaft 50 extends from outside of the cavity 10 to the opening 28 for receiving drive shaft into the convection chamber.

**[0068]** By operating the fan impeller 36 and the ring-shaped heating element 46, hot air can be generated within the convection chamber that is brought in motion by the fan impeller 36 to create a convection heating function for the domestic oven.

**[0069]** In order to enable circulation of the hot air within the cavity, i.e. to circle through the cooking chamber for cooking food and to reenter the convection chamber to hold the hot air in the appropriate temperature range, air gas mixture can be sucked from the cooking chamber into the convection chamber through central openings 52 which the fan cover 34 may comprise.

**[0070]** Further, the fan cover 34 may be formed and dimensioned in a way that the hot air flow brought in motion by the fan impeller 36 can leave the convection chamber substantially only at lateral openings within the fan cover 34 or between fan cover 34 and cavity rear wall 18, so that a circulating hot air function is achieved.

**[0071]** Moreover, the fan impeller 36 can be driven by the drive shaft 50 in a preferred direction of rotation R. Rotation of the fan impeller 36 in the preferred direction of rotation R causes air to be drawn into the convection chamber through the air inlet 24. For this purpose, the fan impeller 36 can comprise supplementary blades 368 on a fan impeller side facing the air inlet 24.

**[0072]** Further, the cavity rear wall 18 may comprise an embossment 66 directed towards the exterior of the cavity 10. The embossment 66 is adapted in form and dimensions to the fan impeller 36 and specifically to the dimensions and position of the supplementary blades 368, such that the supplementary blades 368 can rotate within a space delimited by the embossment 66 and may create a suction air stream within the volume defined by the space formed by the embossment 66 flowing through the air inlet 26 into the convection chamber. Accordingly, the air inlet 26 is located on that part of the cavity rear wall 18 that is part of the embossment 66.

**[0073]** In order to fix the drive unit 40 outside of the cavity 10, a drive unit support 38 is arranged outside of the cavity 10 at a distance to the cavity rear wall 18. The drive unit 40 is fixed to the drive unit support 38.

**[0074]** Further, the air inlet duct element 30 forms a shaft passage 64 extending from a shaft opening within the drive unit support 38 to the opening 28 for receiving the drive shaft 50 within the cavity rear wall 18.

**[0075]** Fig. 5 to 8 illustrate a fan impeller 360 that is advantageously adopted to be used within a cavity as shown in Fig. 1 to 4, but also can be used in alternative cavities. The fan impellers 36 and 360 are substantially identical.

**[0076]** The fan impeller 360 comprises a backing plate 362 and a blade element 364. Main fan blades 366 are formed to the blade elements 364, wherein the blade element 364 is attached to the backing plate 362 by a clinch or clamping connection, more specifically by a bayonet mount. The backing plate 362 is provided as a substantially flat and circular disc comprising a central opening for receiving the drive shaft 50. Accordingly, an axis A of rotation R is defined for the fan impeller 360.

**[0077]** Supplementary fan blades 368 are formed to the backing plate 362. The supplementary fan blades 368 are cut out from the backing plate 362 and bent perpendicular to a main part of the disc forming the backing

plate 362. Alternatively, the supplementary fan blade 368 can be formed to the blade element 364. The main fan blades 366 are arranged on a side of the fan impeller 360 opposite to the side comprising the supplementary blade 368.

**[0078]** The main fan blades 366 comprise a first blade portion 366a extending substantially perpendicular from the backing plate 362 and the second blade portion 366b that is bent relative to the first blade portion 366 in an angle  $\alpha$  that is not a right angle. The second blade portion 366 extends therefore non-parallel to a plane P drawn up or oriented perpendicular to the axis A of rotation R.

**[0079]** The form, position and orientation of the main fan blades 366 define the preferred direction of rotation R, wherein "preferred" shall be understood in that the fan impeller 360 is adopted and suitable to create an air flow very efficiently, when being driven in the preferred direction of rotation R. It is as well possible to drive the fan impeller 360 in the opposite direction and still an air flow would be created, but in a less efficient way.

**[0080]** The fan impeller 360 of the shown embodiment comprises eleven main fan blades 366 and nine supplementary fan blades 368, but also seven, fifteen or seventeen main fan blades 366 have been found to be advantageous.

**[0081]** In any case, it may be advantageous to provide a number of supplementary fan blades 368 of the fan impeller 360 that is smaller, e.g. by two less, than the number of main fan blades 366 and/or to provide the supplementary fan blades 368 smaller in their dimension than the main fan blade 366.

**[0082]** The first and second blade portions 366a, 366b are planar and flat portions of the main fan blades 366. The angle  $\alpha$  enclosed between the first and second blade portions 366a, 366b may be advantageously in the range between  $93^\circ$  and  $120^\circ$ .

**[0083]** Each first blade portion 366 defines a radially outermost tip. By a circular movement of that tip caused by rotation of the fan impeller 360 around the axis A of rotation R, a circular line may be defined to which a tangent  $t_1$  can be determined. The tangent  $t_1$  touching the aforementioned circle line encloses an angle  $\beta$  with a main surface of the first blade portion 366a that is facing in the preferred direction of rotation R. The angle  $\beta$  may be advantageously in the range between  $85^\circ$  and  $45^\circ$ .

**[0084]** Furthermore, each supplementary fan blade 368 may be provided as a flat and planar sheet portion. The longitudinal extension of the sheet portion in a substantially radial direction allows to determine a second tangent  $t_2$  to the outer circumference of the fan impeller 360, more specifically to the outer circumference of the backing plate 362. The second tangent  $t_2$  can enclose an angle  $\gamma$  with a main surface of the corresponding supplementary fan blade 368 that faces the preferred direction of rotation R.

**[0085]** Advantageously, the angle  $\beta$  and the angle  $\gamma$  may be equal or may have a difference in the range between  $0^\circ$  to  $20^\circ$ , in particular between  $5^\circ$  to  $20^\circ$ , preferably

between  $10^\circ$  to  $20^\circ$ .

#### List of reference numerals

5	<b>[0086]</b>	
	10	Cavity
	12	Top wall
	14, 16	Side walls
10	18	Rear wall
	20	Bottom wall
	22	Front opening
	24	Air inlet
	26	Air outlet
15	28	Opening for receiving drive shaft
	30	Air inlet duct element
	30a	First air inlet duct opening
	30b	Second air inlet duct opening
	32	Air outlet duct element
20	34	Fan cover
	36	Fan impeller
	38	Drive unit support
	40	Drive unit
	42	Air inlet duct
25	44	Clearance space
	46	Ring-shaped heating element
	48	Insulation
	50	Drive shaft
	52	Central openings
30	54	Air inlet valve
	56	Air outlet valve
	58	First valve element
	60	Second valve element
	64	Shaft passage
35	66	Embossment
	68	Drive unit support opening
	70	Air outlet duct opening
	360	Fan impeller
	362	Backing plate
40	364	Blade element
	366	Main blades
	366a	First blade portion
	366b	Second blade portion
	368	Supplementary blades
45	A	Axis of rotation
	R	Direction of rotation
	P	Plane
	$\alpha$	Angle
50	$\beta$	Angle
	$\gamma$	Angle
	$t_1, t_2$	tangent

#### 55 Claims

1. Domestic oven, comprising:

- a cavity (10) defining a cooking chamber and having a front opening (22) that is closable by a door for charging and discharging food to be cooked into the cooking chamber;
- at least one heating energy source for supplying heating energy to the cooking chamber;
- at least one air inlet (24) different from the front opening (22) that enables entering of ambient air into the cooking chamber;
- at least one air outlet (26) different from the front opening (22) and from the air inlet (24) that enables air or an air-gas-mixture or an air-gas-steam mixture present in the cooking chamber to leave the cooking chamber.
2. Domestic oven according to claim 1, **characterized in that** the air inlet (24) comprises one hole or a plurality of holes, in particular formed in a regular pattern, that is/are arranged, in particular concentrically, around an opening (28) in a cavity wall, in particular a cavity rear wall (18), for receiving a drive shaft (50) for driving a fan impeller (36, 360) arrangeable or arranged inside of the cavity (10), and/or
- in that** the air outlet (26) comprises one hole or a plurality of holes, in particular formed in a regular pattern, that is/are arranged in a cavity wall, in particular in a top wall, adjacent to a front end of the cavity (10), in particular adjacent to the front opening (22).
3. Domestic oven according to any of the preceding claims, **characterized in that** the domestic oven comprises an air inlet duct element (30) that is attached to an exterior side of a cavity wall, in particular a cavity rear wall (18), in which the one hole or the plurality of holes of the air inlet (24) is/are provided, wherein the air inlet duct element (30) forms an air inlet duct (42) for guiding ambient air to the one hole or the plurality of holes of the air inlet (24), and/or
- in that** the domestic oven comprises an air outlet duct element (32) that is attached to an exterior surface of a cavity wall, in particular a cavity top wall, in which the one hole or the plurality of holes of the air outlet is/are provided, wherein the air outlet duct element (32) forms an air outlet duct for guiding an air-gas-mixture or an air-gas-steam mixture leaving the one hole or the plurality of holes of the air outlet away from the cavity wall.
4. Domestic oven according to any of the preceding claims, **characterized in that** the size of a passage formed by the air inlet (24) is controllable, in particular **in that** the domestic oven comprises an air inlet valve (54) for partially and/or fully opening and/or for partially and/or fully closing the passage formed by the air inlet duct (42) and/or formed by the one hole or plurality of holes of the air inlet (24), and/or
- in that** the size of a passage formed by the air outlet (26) is controllable, in particular **in that** the domestic oven comprises an air outlet valve (56) for partially and/or fully opening and/or for partially and/or fully closing the passage formed by the air outlet duct and/or formed by the one hole or plurality of holes of the air outlet (26).
5. Domestic oven according to claim 4, **characterized in that** the air inlet valve (54) comprises a first valve element (58) that is configured to partially and/or fully open and/or to partially and/or fully close the passage formed by the air inlet duct (42), in particular wherein the air inlet valve (54) comprises an air inlet duct element (30) that is attached to an exterior side of a cavity wall in which the air inlet (24) is provided, such that the air inlet (24) forms an outlet of the air duct, and
- and/or
- in that** the air outlet valve (56) comprises a second valve element (60) that is configured to partially and/or fully open and/or to partially and/or fully close the passage formed by the air outlet duct, in particular wherein the air outlet valve (56) comprises an air outlet duct element (32) that is attached to an exterior side of a cavity wall in which the air outlet (26) is provided, such that the air outlet (26) forms an inlet of the air duct.
6. Domestic oven according to any of the preceding claims, **characterized in that** the air inlet duct element (30) forms a shaft passage (64) for the drive shaft (50) of a fan impeller (36, 360) arrangeable or arranged inside of the cavity (10) that allows the drive shaft (50) to extend straight through the passage of the air inlet duct element (30) and through the opening (28) in the cavity wall, in particular the cavity rear wall (18), for receiving the drive shaft (50) and wherein the air inlet duct element (30) forms the air inlet duct (42) passing from a first air inlet duct opening (30a) being offset from the shaft passage (64) to a second air inlet duct opening (30b) being arranged around the shaft passage (64) and being connected in flow communication with the holes forming the air inlet (24) around the opening (28) for receiving the drive shaft (50) in the cavity rear wall (18).
7. Domestic oven according to any of the preceding claims, comprising at least one microwave heating source and/or at least one steam heating source and/or at least one radiation heating source and comprising at least one controllable air inlet (24) and at least one controllable air outlet (26), wherein the domestic oven is configured to substantially close the controllable air inlet (24) and to partially, preferably slightly, open the controllable air outlet (26)

while the domestic oven carries out a function to generate steam and/or to supply steam to the cooking chamber in order to perform a steam cooking process within the cooking chamber, and/or

wherein the domestic oven is configured to substantially fully open the controllable air inlet (24) and to substantially fully open the controllable air outlet (26) while the domestic oven carries out a function to remove steam that has been generated and/or supplied to the cooking chamber in order to perform a steam cooking process within the cooking chamber, and/or

wherein the domestic oven is configured to fully open the controllable air inlet (24) and to fully open the controllable air outlet (26) while the domestic oven removes moist air that is or has been generated while the domestic oven performs a microwave cooking process, and/or

wherein the domestic oven is configured to fully open the controllable air inlet (24) and to fully open the controllable air outlet (26) while the domestic oven removes moist air that is or has been generated while the domestic oven performs a drying process using the microwave heating source and/or the radiation heating source, and/or

wherein the domestic oven is configured to periodically open and close the controllable air inlet (24) and/or the controllable air outlet (26) while the domestic oven performs a cooking process using the radiation heating source.

8. Domestic oven according to any of the preceding claims, **characterized in that** the domestic oven comprises a convection fan including a fan impeller (36, 360) being arranged within the cavity (10) at a cavity wall, in particular at a rear wall (18) of the cavity, adjacent to the at least one air inlet (24), wherein the convection fan is configured to draw ambient through the at least one air inlet (24) into the cavity (10).

9. Domestic oven according to any of the preceding claims, **characterized in that** the fan impeller (36, 360) includes an impeller body that comprises a first type of impeller blades on an impeller side facing the cooking chamber and a second type of impeller blades different from the first type on an impeller side facing the cavity wall, in particular wherein the second type of impeller blades is configured to draw ambient air through the at least one air inlet (24) into the cavity.

10. Domestic oven according to any of the preceding claims, **characterized in that** the cavity wall, in particular the cavity rear wall (18), at which the fan impeller (36, 360) is arranged comprises an embossment (66) extending towards the exterior side of the cavity (10) and forming a clearance space (44) on the interior side of the cavity (10),

in particular wherein the clearance space (44) has such a shape that the second type of impeller blades can be arranged within the space or adjacent thereto and at a close distance to the cavity wall, preferably **in that** a slight underpressure can be or is generated within the clearance space (44) by the rotating fan impeller (36, 360) and/or

in particular wherein the embossment (66) has such a shape that it prevents or hinders the drawn in ambient air to flow in a vertical direction and and/or that it guides the drawn in ambient air in a lateral direction.

11. Fan impeller (36, 360) defining an axis (A) of rotation (R) and comprising a backing plate (362) and at least two or three or a plurality of fan blades (366, 368) being attached to the backing plate (362), wherein the backing plate (362) is formed as a substantially flat circular disc and wherein at least one or at least two or all of the fan blades (366, 368) comprise a first blade portion (366a) extending substantially from the backing plate (362) and a second blade portion (366b) extending as a free end of the fan blade(s) (366, 368) from the first blade portion (366a) in an angle ( $\alpha$ ) such that the second blade portion (366b) extends non-parallel to a plane being drawn up perpendicular to the axis (A) of rotation (R).

12. Fan impeller (36, 360) according to claim 11, **characterized in that** the first blade portion (366a) and/or the second blade portion (366b) are planar and flat portions of the fan blades (366, 368) and wherein the angle ( $\alpha$ ) between the first blade portion (366a) and the second blade portion (366b) is in the range between  $93^\circ$  and  $120^\circ$ , in particular between  $95^\circ$  and  $110^\circ$ , preferably is  $100^\circ$ .

13. Fan impeller (36, 360) according to any of the preceding claims, **characterized in that** each first blade portion (366a) defines an radially outermost tip of the fan blade (366, 368) to which it belongs, wherein the outermost tip defines a circle upon rotation of the fan impeller, wherein a tangent to the circle and touching the outermost tip encloses an angle ( $\beta$ ) with a main surface of the first blade portion (366a), wherein the angle ( $\beta$ ) is in the range between  $85^\circ$  and  $45^\circ$ , in particular between  $70^\circ$  and  $50^\circ$ , preferably is  $60^\circ$ .

14. Fan impeller (36, 360) according to any of the preceding claims, **characterized in that** the fan impeller (36, 360) comprises main fan blades (366) comprising the first and second blade portions (366a, 366b) and supplementary fan blades (368), wherein the supplementary fan blades (368) are arranged on the side of the fan impeller (36, 360) that is opposite to the side of the fan impeller (36, 360) on which the main fan blades (366) are arranged, wherein the supplementary fan blades (368) are planar and flat fan blades and wherein the first blade portion (366a) of the main fan blades (366) and the supplementary fan blades (368) extend substantially the direction of rotation (R) of the fan impeller (36, 360), and wherein the main surfaces of the first blade portions (366a) and the main surfaces of the supplementary fan blades (368) are arranged non-parallel to each other.

5

10

15

15. Domestic oven according to any of the claims 1 to 10, **characterized in that** the fan impeller (36, 360) is a fan impeller (36, 360) according to any of the claims 11 to 14.

20

25

30

35

40

45

50

55

FIG.1

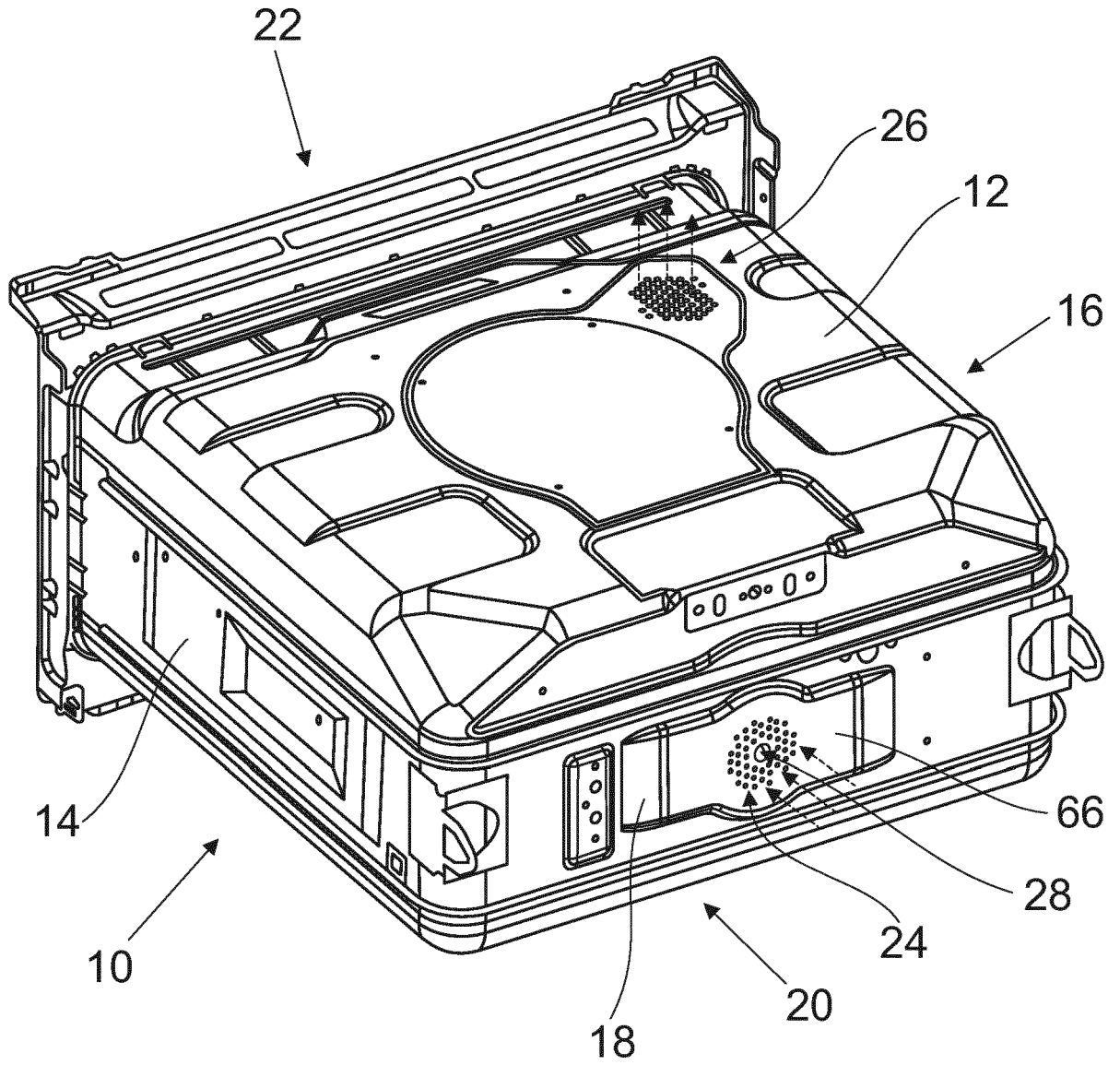

FIG. 2A

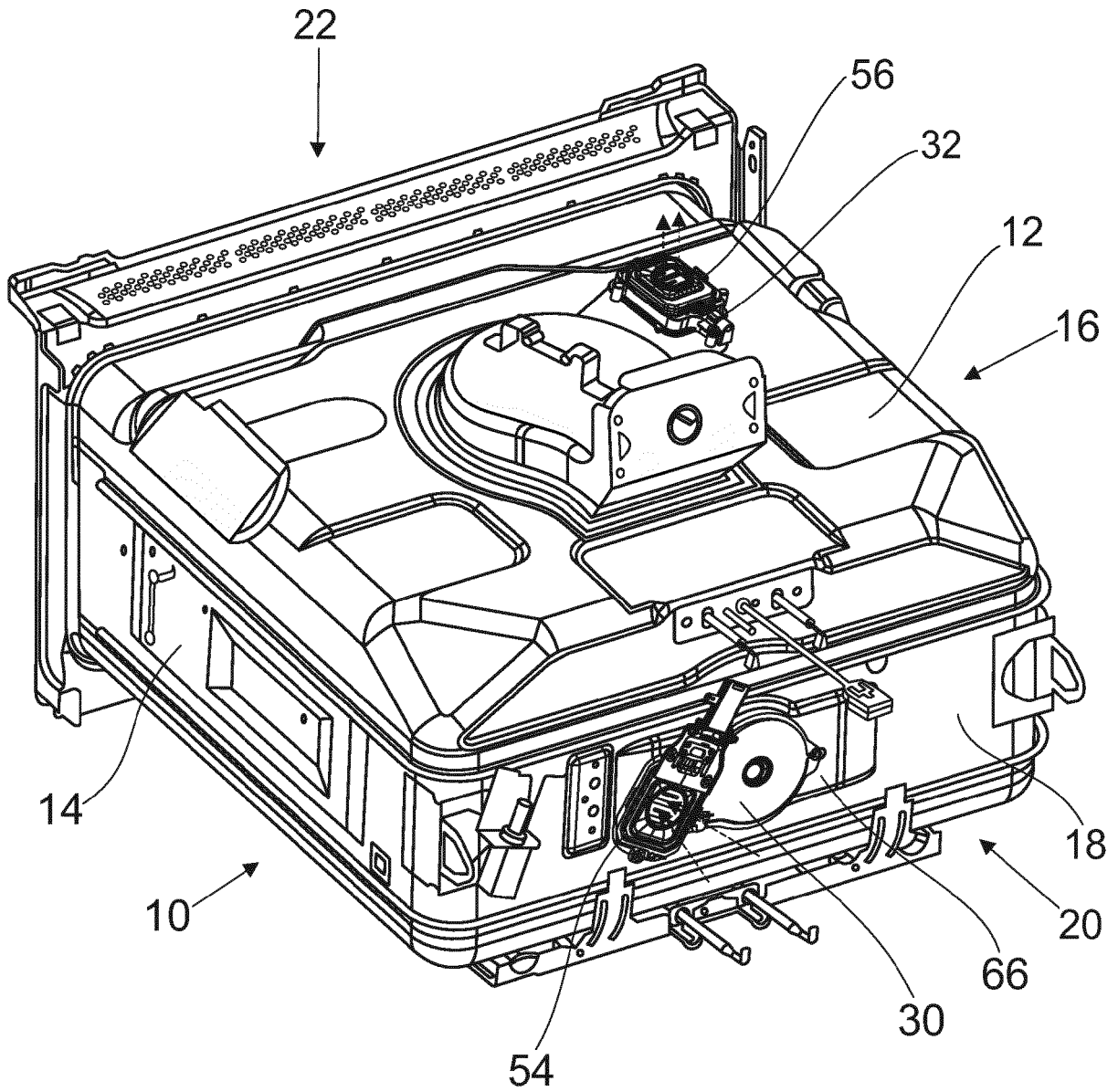

FIG.2B

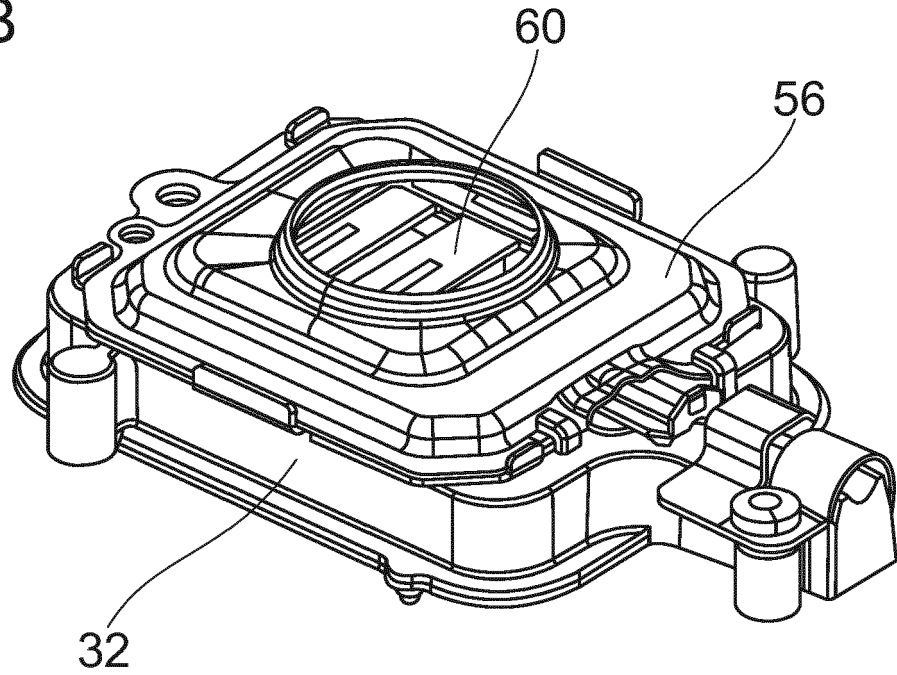

FIG.2C

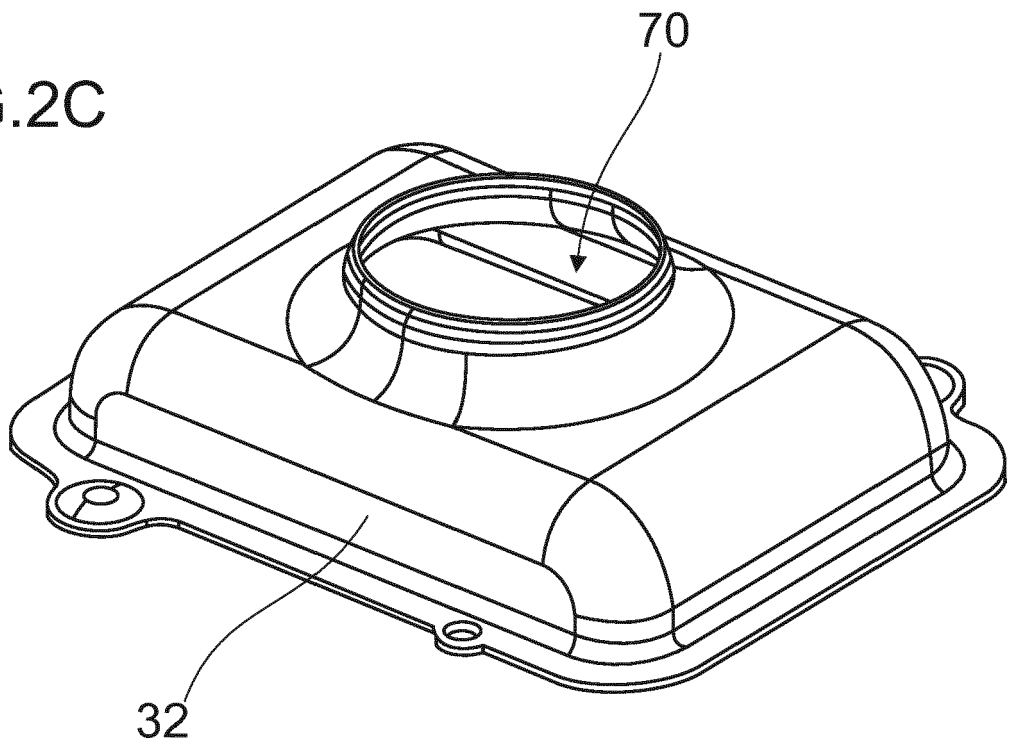

FIG.2D

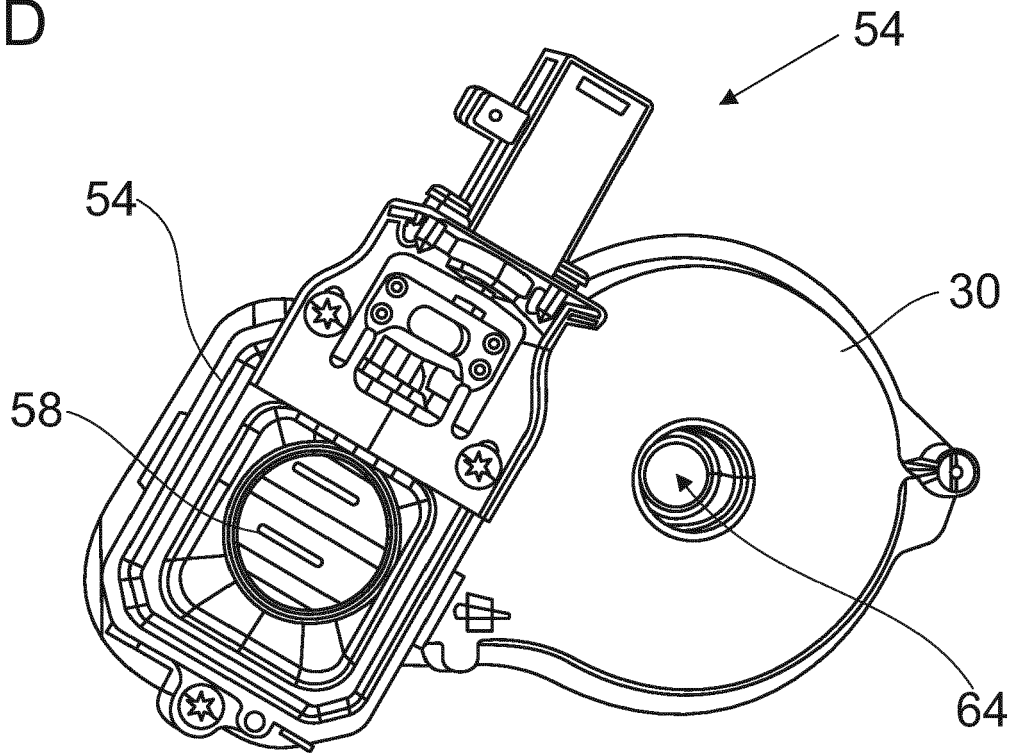

FIG.2E

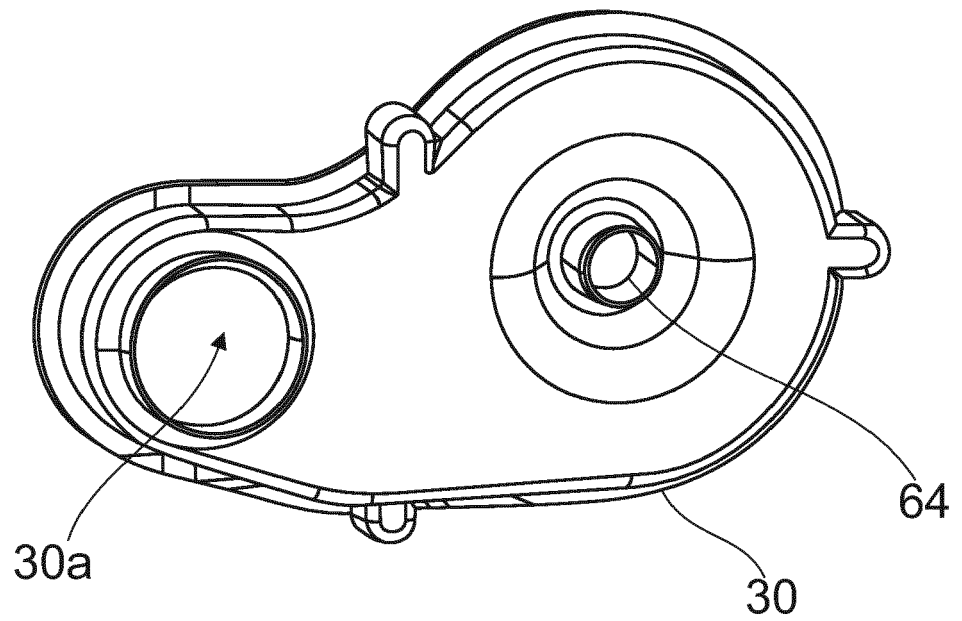

FIG.3

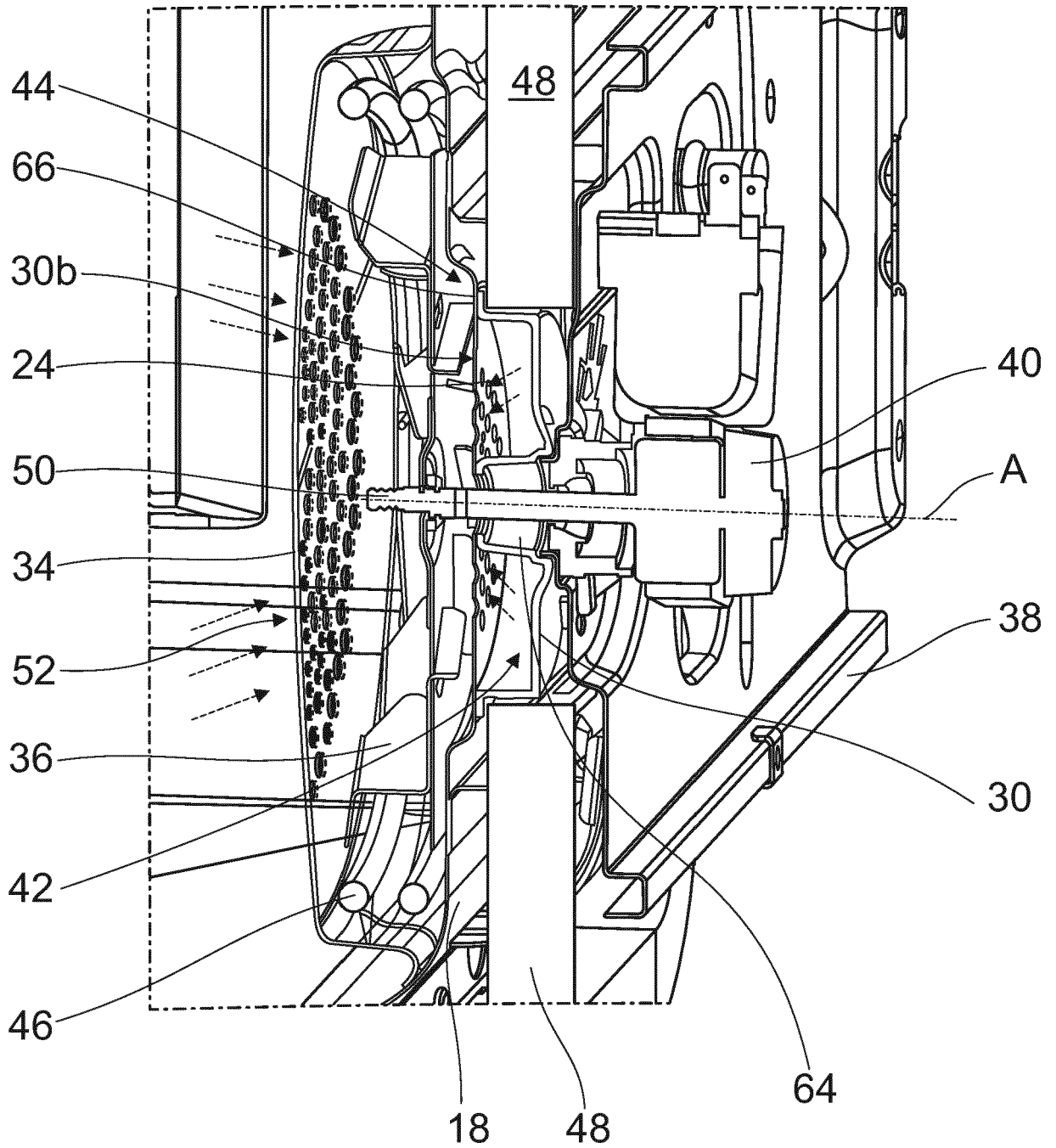

FIG.4

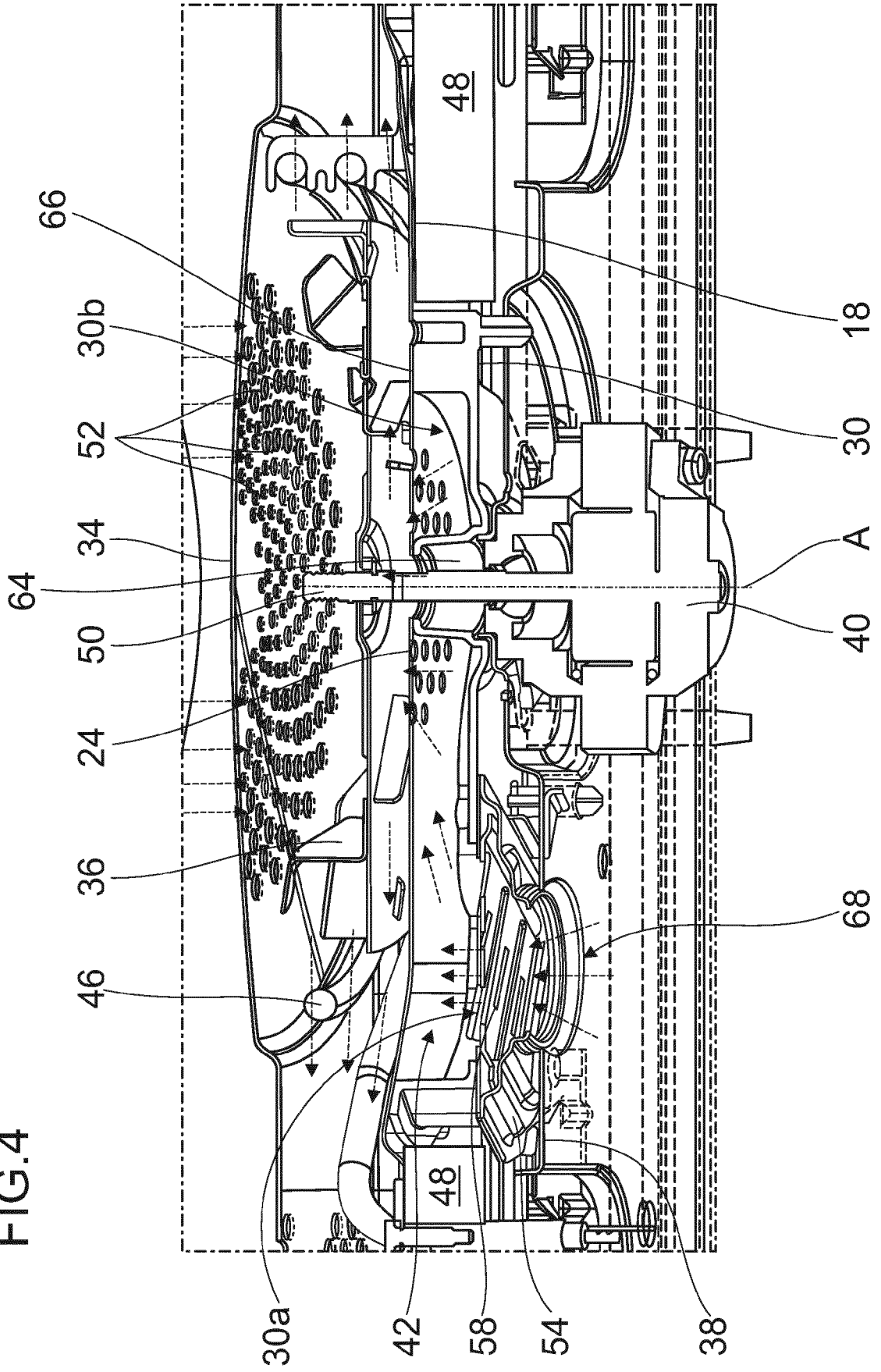

FIG.5

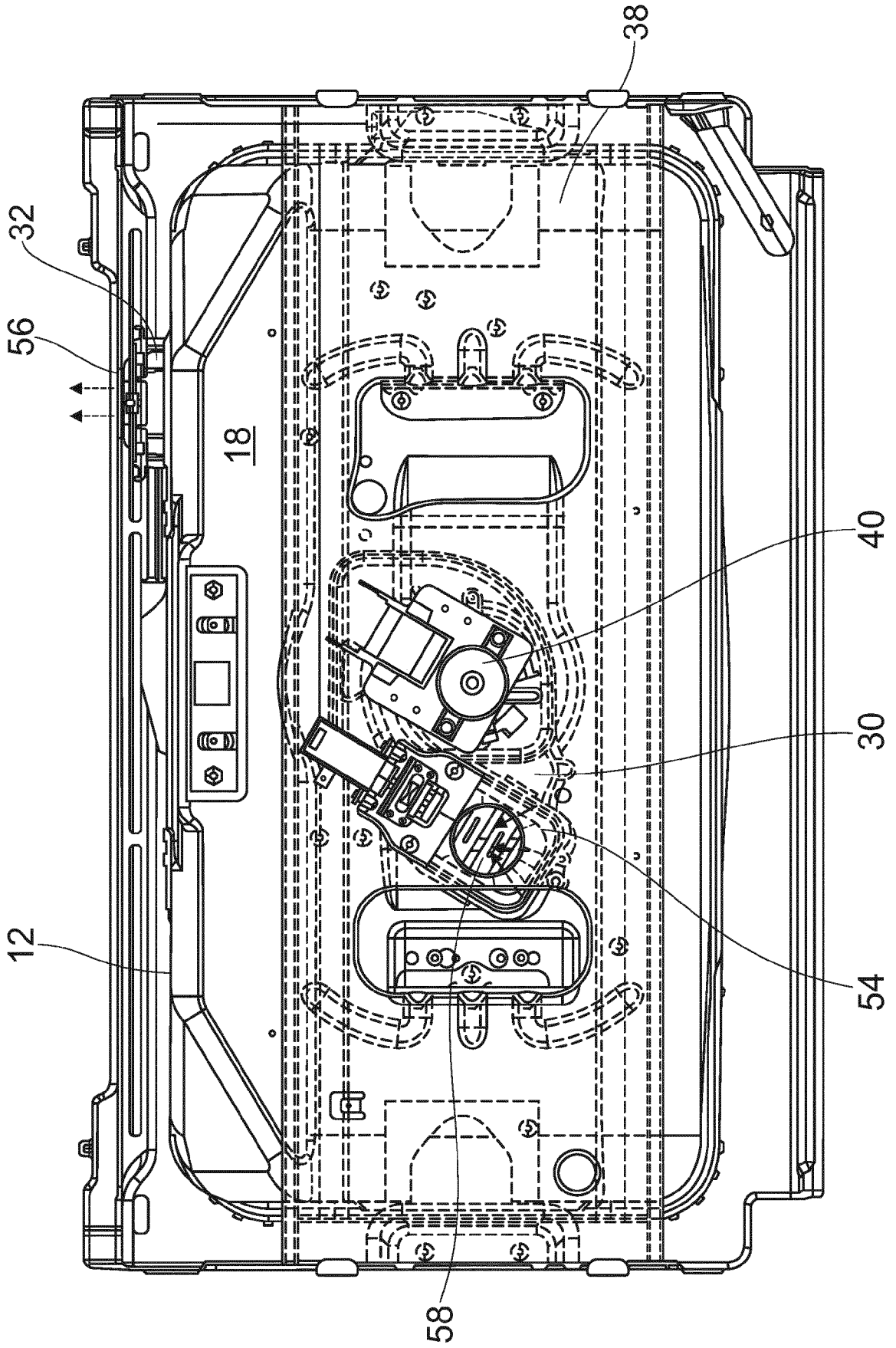

FIG.6

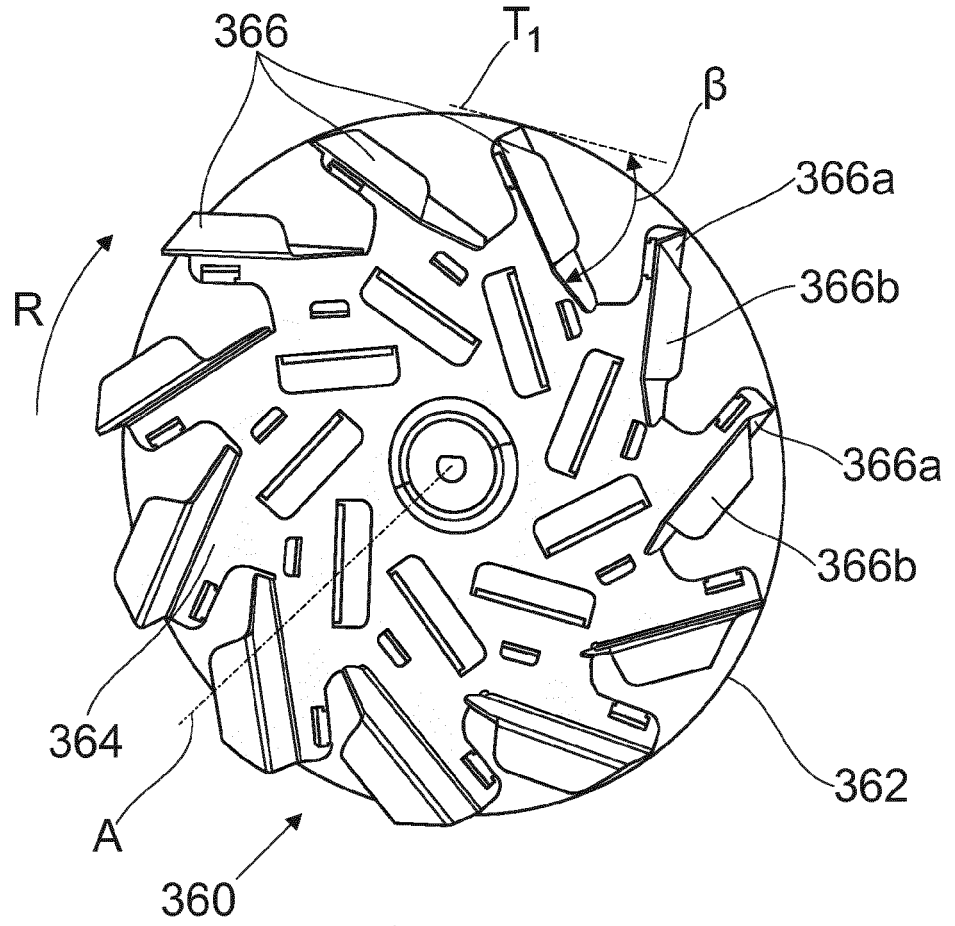

FIG.7

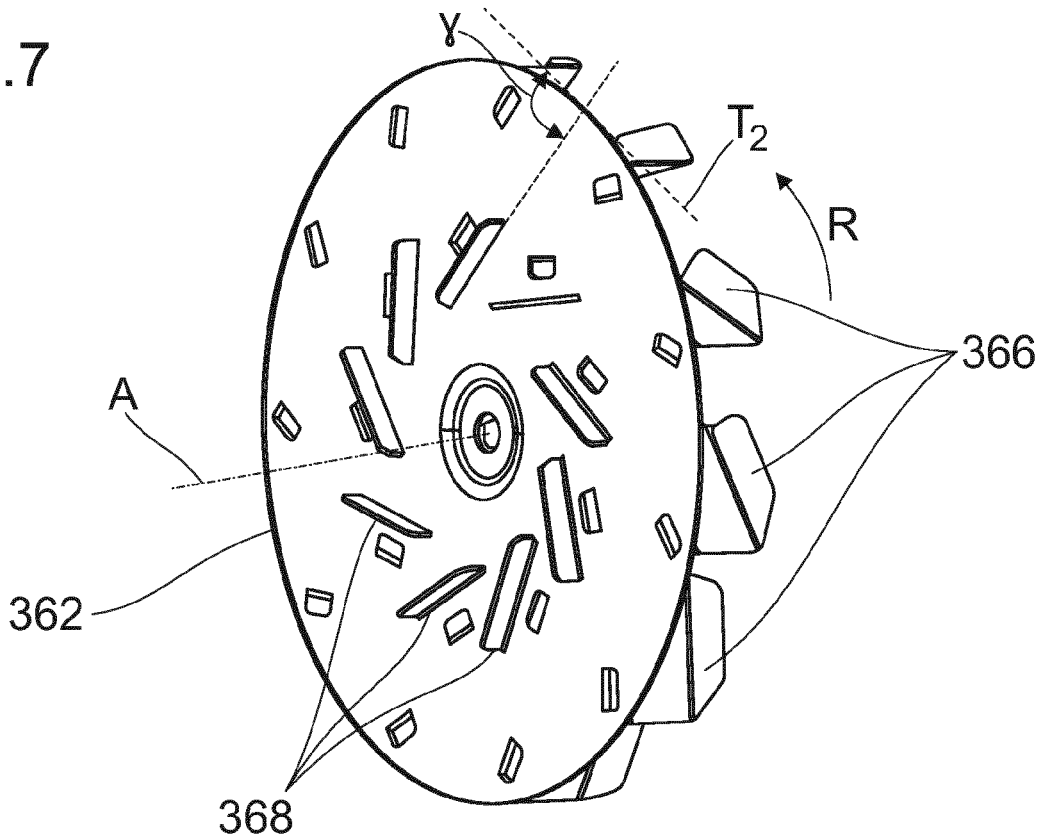
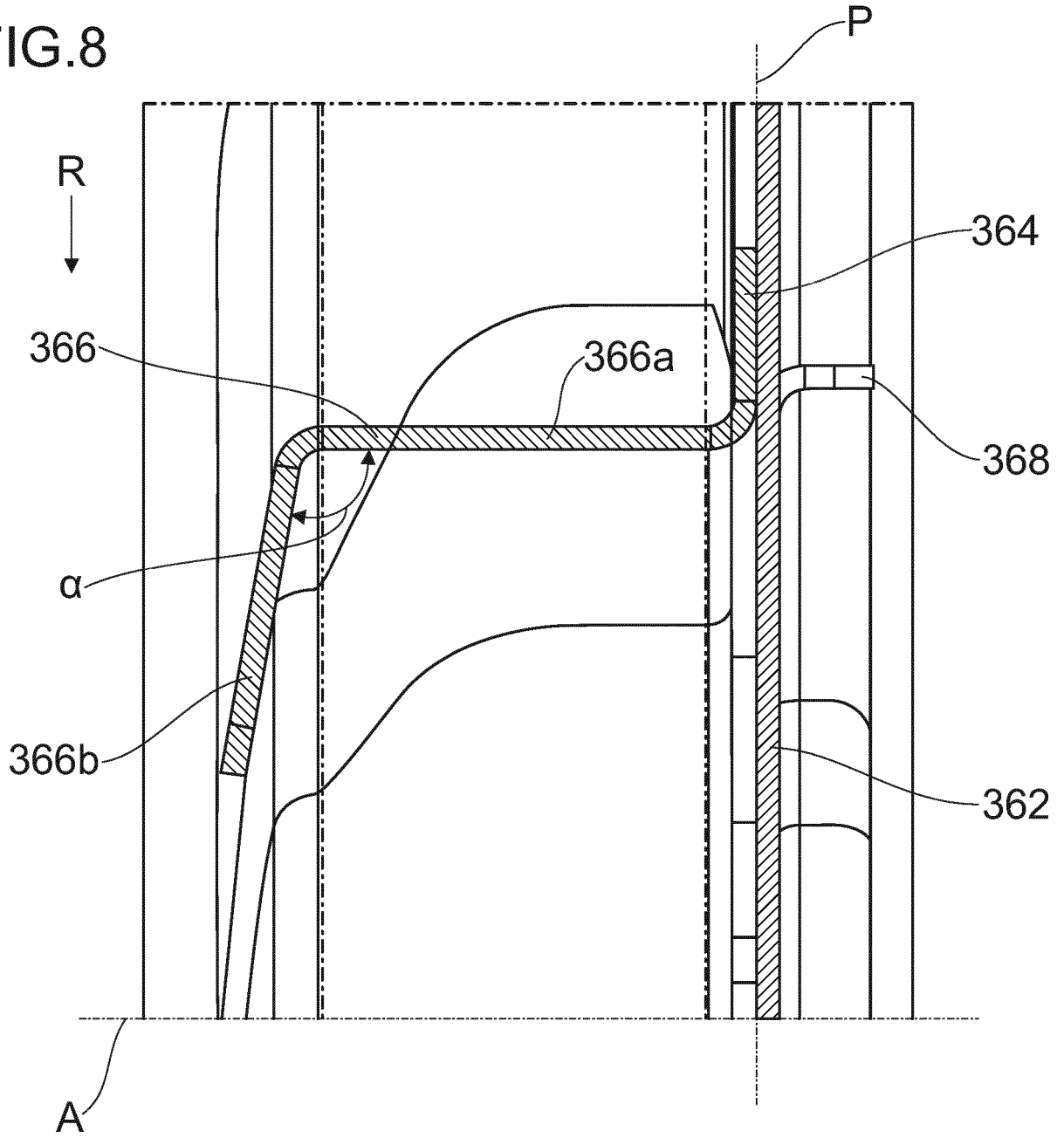

FIG.8







Application Number

EP 22 17 0737

5

**CLAIMS INCURRING FEES**

The present European patent application comprised at the time of filing claims for which payment was due.

10

Only part of the claims have been paid within the prescribed time limit. The present European search report has been drawn up for those claims for which no payment was due and for those claims for which claims fees have been paid, namely claim(s):

15

No claims fees have been paid within the prescribed time limit. The present European search report has been drawn up for those claims for which no payment was due.

20

**LACK OF UNITY OF INVENTION**

The Search Division considers that the present European patent application does not comply with the requirements of unity of invention and relates to several inventions or groups of inventions, namely:

25

**see sheet B**

30

All further search fees have been paid within the fixed time limit. The present European search report has been drawn up for all claims.

35

As all searchable claims could be searched without effort justifying an additional fee, the Search Division did not invite payment of any additional fee.

40

Only part of the further search fees have been paid within the fixed time limit. The present European search report has been drawn up for those parts of the European patent application which relate to the inventions in respect of which search fees have been paid, namely claims:

45

None of the further search fees have been paid within the fixed time limit. The present European search report has been drawn up for those parts of the European patent application which relate to the invention first mentioned in the claims, namely claims:

50

**1-10**

55

The present supplementary European search report has been drawn up for those parts of the European patent application which relate to the invention first mentioned in the claims (Rule 164 (1) EPC).



**LACK OF UNITY OF INVENTION  
SHEET B**

Application Number  
**EP 22 17 0737**

5

The Search Division considers that the present European patent application does not comply with the requirements of unity of invention and relates to several inventions or groups of inventions, namely:

10

**1. claims: 1-10**

**Domestic oven with air inlet and air outlet**

---

15

**2. claims: 11-15**

**Fan impeller and oven with fan impeller**

---

20

25

30

35

40

45

50

55

ANNEX TO THE EUROPEAN SEARCH REPORT  
ON EUROPEAN PATENT APPLICATION NO.

EP 22 17 0737

5 This annex lists the patent family members relating to the patent documents cited in the above-mentioned European search report.  
The members are as contained in the European Patent Office EDP file on  
The European Patent Office is in no way liable for these particulars which are merely given for the purpose of information.

20-09-2022

Patent document cited in search report	Publication date	Patent family member(s)	Publication date
US 2002179588 A1	05-12-2002	AT 270419 T	15-07-2004
		CA 2365327 A1	15-06-2002
		DE 60104077 T2	04-11-2004
		EP 1215444 A1	19-06-2002
		ES 2221885 T3	16-01-2005
		FR 2818359 A1	21-06-2002
		US 2002179588 A1	05-12-2002
-----			
DE 202011051026 U1	17-10-2011	NONE	
-----			
DE 102016215650 A1	22-02-2018	CN 109564005 A	02-04-2019
		DE 102016215650 A1	22-02-2018
		EP 3500800 A1	26-06-2019
		PL 3500800 T3	31-05-2021
		US 2019137112 A1	09-05-2019
		WO 2018033384 A1	22-02-2018
-----			
DE 10351476 A1	16-06-2005	DE 10351476 A1	16-06-2005
		FR 2865267 A1	22-07-2005
		US 2005092313 A1	05-05-2005
-----			
DE 102005047455 A1	13-04-2006	NONE	
-----			
US 6943322 B1	13-09-2005	NONE	
-----			

**REFERENCES CITED IN THE DESCRIPTION**

*This list of references cited by the applicant is for the reader's convenience only. It does not form part of the European patent document. Even though great care has been taken in compiling the references, errors or omissions cannot be excluded and the EPO disclaims all liability in this regard.*

**Patent documents cited in the description**

- EP 3029382 A1 [0002]