



(11) **EP 4 300 019 A1**

(12) **EUROPEAN PATENT APPLICATION**
published in accordance with Art. 153(4) EPC

(43) Date of publication:
03.01.2024 Bulletin 2024/01

(51) International Patent Classification (IPC):
F25D 23/02^(2006.01) F25D 11/02^(2006.01)

(21) Application number: **22778308.1**

(52) Cooperative Patent Classification (CPC):
F25D 11/02; F25D 23/02

(22) Date of filing: **13.01.2022**

(86) International application number:
PCT/CN2022/071769

(87) International publication number:
WO 2022/206119 (06.10.2022 Gazette 2022/40)

(84) Designated Contracting States:
AL AT BE BG CH CY CZ DE DK EE ES FI FR GB GR HR HU IE IS IT LI LT LU LV MC MK MT NL NO PL PT RO RS SE SI SK SM TR
Designated Extension States:
BA ME
Designated Validation States:
KH MA MD TN

- **ZHANG, Hao**
Qingdao, Shandong 266101 (CN)
- **LYU, Peng**
Qingdao, Shandong 266101 (CN)
- **WANG, Haijuan**
Qingdao, Shandong 266101 (CN)
- **LIU, Zhanzhan**
Qingdao, Shandong 266101 (CN)
- **SONG, Xiangpeng**
Qingdao, Shandong 266101 (CN)
- **ZHAO, Kunkun**
Qingdao, Shandong 266101 (CN)

(30) Priority: **02.04.2021 CN 202110362841**

(71) Applicants:

- **Qingdao Haier Refrigerator Co., Ltd.**
Laoshan District
Qingdao
Shandong 266101 (CN)
- **Haier Smart Home Co., Ltd.**
Qingdao, Shandong 266101 (CN)

(74) Representative: **Gille Hrabal**
Partnerschaftsgesellschaft mbB
Patentanwälte
Brucknerstraße 20
40593 Düsseldorf (DE)

(72) Inventors:

- **ZHAO, Yanfeng**
Qingdao, Shandong 266101 (CN)

(54) **REFRIGERATOR**

(57) A refrigerator, comprising: a refrigerator body comprising a storage chamber having a front opening; a side-by-side door body assembly comprising a first door body and a second door body which are respectively pivotally disposed on two sides of the front opening so as to open or close the storage chamber; and a vertical beam, which is rotatably mounted on the side of the first door body away from the pivoting center of the first door body and abuts against the second door body when the first door body and the second door body are closed so as to seal gaps among the first door body, the second door body, and the refrigerator body; a notch being

formed in the position of the front end of the top wall of the storage chamber opposite to the vertical beam, and the top end of the vertical beam being accommodated in the notch when abutting against the refrigerator body. According to the solution of the present invention, the notch is formed in the front side of the top wall of the storage chamber, so that the top end of the vertical beam is accommodated in the notch when abutting against the refrigerator body, thereby preventing cold air in the storage chamber from leaking from the top end of the vertical beam, and further improving the refrigeration effect of the refrigerator.

EP 4 300 019 A1

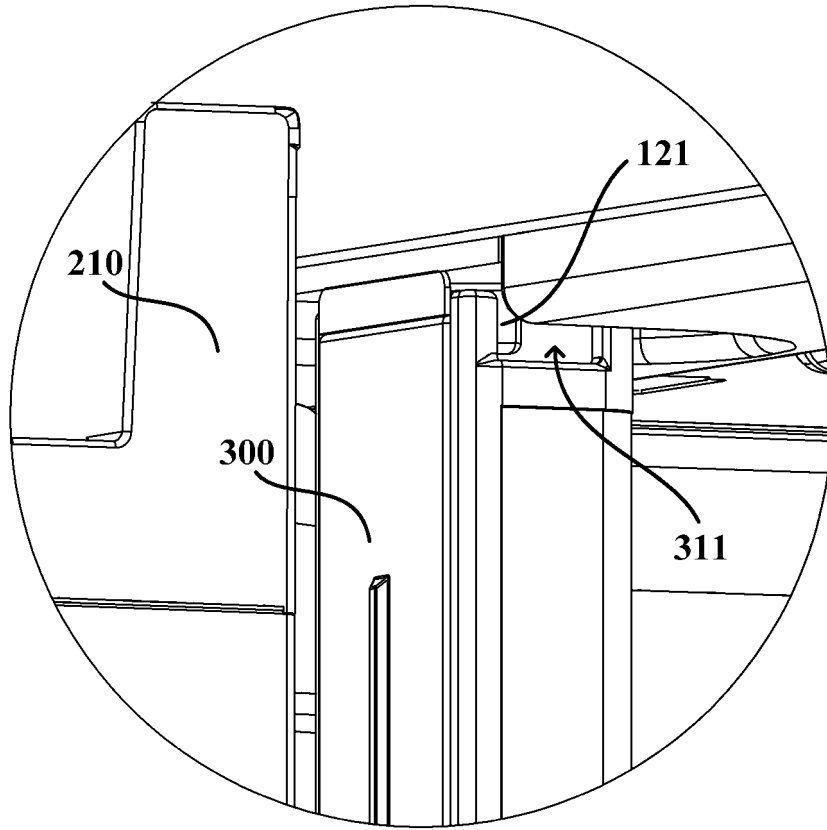

FIG.3

Description

TECHNICAL FIELD

[0001] The present invention relates to the field of household appliances, and in particular, to a refrigerator.

BACKGROUND

[0002] With an increase of a demand of users for a volume of a storage chamber of a refrigerator, the storage chamber of the refrigerator circulating on the market at present has an increasingly larger volume, and in order to achieve a better use effect, the large-volume refrigerator usually has a side-by-side structure. Since a certain gap exists between a left door and a right door, a vertical beam for sealing is required to be mounted on one door, so as to prevent cold air in the storage chamber from leaking from the gap between the two doors. However, a certain gap still exists between a top of the vertical beam and a refrigerator body of the refrigerator, and the cold air in the storage chamber can still blow out through the gap in an upper portion of the vertical beam, thereby influencing a refrigerating effect of the refrigerator, and reducing use experiences of customers.

[0003] Further, for the refrigerator with the side-by-side doors (for example, the French refrigerator, or the like) in a prior art, generally, a side-by-side door body assembly is only provided at an opening of a refrigerating compartment, and a freezing compartment usually has a drawer-type structure. However, in a long-term working process of the drawer-type structure of the freezing compartment, deformation is prone to be caused by long-term pressing, such that a drawer cannot be closed tightly; a size of a storage object stored in the freezing compartment in a height direction is limited, thus reducing a rate of effective utilization of a storage space of the freezing compartment by the user, and influencing the use experience of the user.

SUMMARY

[0004] An object of the present invention is to provide a refrigerator which solves at least one of the above-mentioned technical problems.

[0005] A further object of the present invention is to provide a side-by-side door body assembly with a rotatable vertical beam at an opening of a freezing compartment.

[0006] Another object of the present invention is to improve a sealing effect of the vertical beam of the refrigerator and avoid cold air in a storage chamber of the refrigerator from leaking from a top end of the vertical beam.

[0007] Another object of the present invention is to improve a heat insulation effect of the vertical beam, thereby improving use experiences of a user.

[0008] In particular, the present invention is directed

to a refrigerator, comprising:

a refrigerator body comprising a storage chamber having a front opening;

a side-by-side door body assembly comprising a first door body and a second door body pivotably provided on both sides of the front opening respectively, so as to open or close the storage chamber;

a vertical beam rotatably mounted on a side of the first door body apart from a pivoting center of the first door body, and abutting against the second door body when the first door body and the second door body are closed, so as to close a gap among the first door body, the second door body and the refrigerator body;

wherein a notch is formed at a position of a front end of a top wall of the storage chamber opposite to the vertical beam, and a top end of the vertical beam is accommodated in the notch when abutting against the refrigerator body.

[0009] Further, a first guide device and a second guide device are provided at the top end of the vertical beam and an inner side of the top wall of the storage chamber respectively, such that the vertical beam is turned over when entering or exiting from the notch.

[0010] Further, the first guide device is configured as a guide groove; the second guide device is configured as a guide protrusion; and the guide protrusion is inserted into the guide groove when the top end of the vertical beam is received in the notch.

[0011] Further, the guide groove is arc-shaped, and an end of the guide groove apart from a rotating shaft of the vertical beam is provided with an opening, such that the guide protrusion can be inserted into or withdrawn from the guide groove through the opening;

when the first door body rotates relative to the refrigerator body, the vertical beam is turned over by limiting the guide groove by the guide protrusion.

[0012] Further, the guide protrusion has a forward guide tip, and the opening of the guide groove has a greater size than the guide tip, such that the guide protrusion can be inserted into the guide groove.

[0013] Further, from the guide tip, the guide protrusion extends along a plane to form a first sidewall and extends along a cambered surface to form a second sidewall, such that the guide groove is guided by the first sidewall and the second sidewall.

[0014] Further, an accommodating portion is further provided on a side of the vertical beam close to the first door body, and the vertical beam further comprises:

a hinge assembly configured to connect the first door body and the vertical beam and having a hinge shaft provided in the accommodating portion.

[0015] Further, the hinge shaft comprises:

a first shaft portion slidably provided in the accommodating portion in a longitudinal direction of the ver-

tical beam, a top surface thereof being formed as a cam surface; and
 a second shaft portion provided above the first shaft portion and having a lower end surface fitted with the top surface of the first shaft portion;
 the hinge assembly further comprises a fixed portion extending from the second shaft portion and mounted on the side of the first door body apart from the pivoting center of the first door body.

[0016] Further, the hinge assembly further comprises a compression spring having one end abutting against a bottom surface of the first shaft portion and the other end abutting against a bottom surface of the accommodating portion.

[0017] Further, the storage chamber is configured as a freezing compartment; the refrigerator body is further provided with a refrigerating compartment with a front opening, a refrigerating door is provided at the opening of the refrigerating compartment, and a refrigerating vertical beam is rotatably mounted on the refrigerating door; the vertical beam of the freezing compartment has a greater thickness than the refrigerating vertical beam of the refrigerating compartment.

[0018] In the refrigerator according to the present invention, the side-by-side door body assembly is provided at the opening of the freezing compartment, and the rotatable vertical beam is provided on the side-by-side door body assembly, such that a sealing performance of the freezing compartment is guaranteed, and meanwhile, a limitation of the freezing compartment on a height of a storage object is released, a space utilization rate of the freezing compartment is improved, and the use experience of the user is further improved.

[0019] In the refrigerator according to the present invention, the notch is formed at the position of the front end of the top wall of the storage chamber of the refrigerator opposite to the vertical beam, and the top end of the vertical beam is accommodated in the notch when abutting against the refrigerator body, thereby preventing the cold air in the storage chamber from leaking from the top end of the vertical beam, then guaranteeing a sealing performance of an upper portion of the vertical beam, further improving a refrigerating effect of the refrigerator, and improving the use experience of the user.

[0020] Further, in the refrigerator according to the present invention, the first guide device at the top end of the vertical beam is configured as the guide groove, and the second guide device on the inner side of the top wall of the storage chamber is configured as the guide protrusion, thereby avoiding the cold leakage at the top end of the vertical beam, and meanwhile ensuring that the vertical beam can be normally turned over when entering and exiting from the notch, then ensuring that the door of the refrigerator can be normally opened or closed in a using process, and further improving the use experience of the user.

[0021] Further, in the refrigerator according to the

present invention, the accommodating portion and the hinge assembly for connecting the first door body and the vertical beam are provided on the side of the vertical beam close to the first door body, the hinge shaft in the hinge assembly includes the first shaft portion and the second shaft portion which are located in the accommodating portion and provided along the longitudinal direction of the vertical beam, and the top surface of the first shaft portion and the lower end surface of the second shaft portion are configured as the cam surfaces fitted with each other, such that a space occupied by the hinge assembly in the vertical beam is reduced while the normal overturning of the vertical beam is guaranteed, and therefore, the vertical beam can be filled with more foaming materials, thereby further improving the heat insulation effect of the vertical beam.

[0022] Further, in the refrigerator according to the present invention, the thicknesses of the vertical beams located in different storage chambers are fitted with functions of the storage chambers, such that the thickness of the vertical beam located in the freezing compartment is greater than the thickness of the refrigerating vertical beam located in the refrigerating compartment, thereby further improving the heat insulation effect of the vertical beam and a refrigerating effect of the refrigerator.

[0023] The above and other objects, advantages and features of the present invention will become more apparent to those skilled in the art from the following detailed description of specific embodiments thereof taken in conjunction with the accompanying drawings.

BRIEF DESCRIPTION OF THE DRAWINGS

[0024] Some specific embodiments of the invention will be described in detail hereinafter by way of example and not by way of limitation with reference to the accompanying drawings. The same reference numerals identify the same or similar components or parts in the drawings. Those skilled in the art should appreciate that the drawings are not necessarily drawn to scale. In the drawings:

FIG. 1 is a schematic structural diagram of a refrigerator according to an embodiment of the present invention;

FIG. 2 is a schematic structural diagram of a refrigerator according to an embodiment of the present invention with a first door body in a closed state;

FIG. 3 is a partial enlarged view of region A of FIG. 2;

FIG. 4 is a schematic diagram of a mounting structure of a first door body and a vertical beam of a refrigerator according to an embodiment of the present invention;

FIG. 5 is a perspective view of a vertical beam of a refrigerator according to an embodiment of the present invention;

FIG. 6 is a schematic structural diagram of a storage chamber of a refrigerator according to an embodiment of the present invention;

FIG. 7 is a partial enlarged view of region B of FIG. 6; FIG. 8 is an exploded view of a vertical beam of a refrigerator according to an embodiment of the present invention;

FIG. 9 is a schematic structural diagram of a vertical beam of a refrigerator according to an embodiment of the present invention; and

FIG. 10 is a partial enlarged view of region C of FIG. 9.

DETAILED DESCRIPTION

[0025] Hereinafter, the present invention will be described in detail in conjunction with specific embodiments shown in FIGS. 1 to 10. However, these embodiments have no limitations on the present invention, and any transformations of structure, method, or function made by persons skilled in the art according to these embodiments fall within the protection scope of the present invention.

[0026] In the description of the present embodiment, it should be understood that the terms "transverse", "longitudinal", "thickness", "upper", "lower", "front", "top", "bottom", or the like, indicate orientations or positional relationships based on orientations in a normal use state of a refrigerator 10 and can be determined with reference to orientations or positional relationships shown in the drawings, for example, "front" indicating an orientation refers to a side of the refrigerator 10 facing a user during normal use. The terms are used only for describing the present invention and for description simplicity, but do not indicate or imply that an indicated device or element must have a specific orientation or be constructed and operated in a specific orientation. Therefore, it cannot be understood as a limitation on the present invention.

[0027] FIG. 1 is a schematic structural diagram of a refrigerator 10 according to an embodiment of the present invention. FIG. 2 is a schematic structural diagram of a refrigerator 10 according to an embodiment of the present invention with a first door body 210 in a closed state. FIG. 3 is a partial enlarged view of region A of FIG. 2. FIG. 4 is a schematic diagram of a mounting structure of a first door body 210 and a vertical beam 300 of a refrigerator 10 according to an embodiment of the present invention.

[0028] In FIG. 2, a second door body 220 located on a right side of the refrigerator 10 is hidden to better show a corresponding structure of the vertical beam 300 of the refrigerator 10.

[0029] The present embodiment first provides a refrigerator 10, and the refrigerator 10 may generally include a refrigerator body 100, a side-by-side door body assembly 200 and a vertical beam 300. The refrigerator body 100 includes a storage chamber 110 having a front opening; the side-by-side door body assembly 200 includes a first door body 210 and a second door body 220 pivotably provided on both sides of the front opening respectively, so as to open or close the storage chamber 110.

The vertical beam 300 is rotatably mounted on a side of the first door body 210 apart from a pivoting center of the first door body 210, and abuts against the second door body 220 when the first door body 210 and the second door body 220 are closed, so as to close a gap among the first door body 210, the second door body 220 and the refrigerator body 100; a notch 111 is formed at a position of a front end of a top wall of the storage chamber 110 opposite to the vertical beam 300, and a top end of the vertical beam 300 is accommodated in the notch 111 when abutting against the refrigerator body 100.

[0030] When the side-by-side door body assembly 200 is closed, a gap is formed between the first door body 210 and the second door body 220, and in some embodiments, the first door body 210 and the second door body 220 of the side-by-side door body assembly 200 have the same size, and the gap is located in a middle of the side-by-side door body assembly 200. In other embodiments, the first door body 210 and the second door body 220 have different transverse sizes, and the gap is located at a position deviated from the middle of the side-by-side door body assembly 200.

[0031] According to the solution of the present embodiment, the side-by-side door body assembly 200 is provided at the opening of the storage chamber 110 of the refrigerator 10, and the rotatable vertical beam 300 is provided on the first door body 210 of the side-by-side door body assembly 200, such that the vertical beam 300 abuts against the second door body 220 and the refrigerator body 100 when the first door body 210 and the second door body 220 are closed, so as to seal the gap among the first door body 210, the second door body 220 and the refrigerator body 100, thereby preventing cold air in the storage chamber 110 from leaking from the gap between the first door body 210 and the second door body 220, and guaranteeing a refrigerating effect of the refrigerator 10.

[0032] Further, according to the solution of the present embodiment, the notch 111 is formed at the position of the front end of an inner side of the top wall of the storage chamber 110 of the refrigerator 10 opposite to the vertical beam 300, and the top end of the vertical beam 300 is accommodated in the notch 111 when abutting against the refrigerator body 100, thereby preventing the cold air in the storage chamber 110 from leaking from the top end of the vertical beam 300, then guaranteeing a sealing performance of the top end of the vertical beam 300, further improving the refrigerating effect of the refrigerator 10, and improving a use experience of a user.

[0033] FIG. 5 is a perspective view of a vertical beam 300 of a refrigerator 10 according to an embodiment of the present invention. FIG. 6 is a schematic structural diagram of a storage chamber 110 of a refrigerator 10 according to an embodiment of the present invention. FIG. 7 is a partial enlarged view of region B of FIG. 6.

[0034] A first guide device 310 and a second guide device 120 are provided at the top end of the vertical beam 300 and the inner side of the top wall of the storage

chamber 110 respectively, such that the vertical beam 300 is turned over when entering or exiting from the notch 111.

[0035] As shown in FIGS. 5 to 7, according to the solution of the present embodiment, the first guide device 310 is provided at the top end of the vertical beam 300, and the second guide device 120 is provided at the position (i.e., in the notch 111 formed at the front end of the top wall of the storage chamber 110) of the inner side of the top wall of the storage chamber 110 opposite to the vertical beam 300, such that when the top end of the vertical beam 300 enters or exits from the notch 111 (that is, when the first door body 210 is opened or closed), the top end can be smoothly turned over under a combined action of the first guide device 310 and the second guide device 120, thereby guaranteeing normal use of the side-by-side door body assembly 200 of the refrigerator 10, and improving the use experience of the user.

[0036] The first guide device 310 is configured as a guide groove 311; the second guide device 120 is configured as a guide protrusion 121; the guide protrusion 121 is inserted into the guide groove 311 when the top end of the vertical beam 300 is received in the notch 111.

[0037] According to the solution of the present embodiment, the first guide device 310 located at the top end of the vertical beam 300 is configured as the guide groove 311, and the second guide device 120 located on the inner side of the front end of the top wall of the storage chamber 110 is configured as the guide protrusion 121 fitted with the guide groove 311, such that the structural arrangement of the first guide device 310 and the second guide device 120 is better fitted with a shape of the notch 111 formed on the inner side of the top wall of the storage chamber 110, and the top end of the vertical beam 300 can better abut against the notch 111 while the first guide device 310 and the second guide device 120 can be guaranteed to smoothly guide the vertical beam 300 to be turned over.

[0038] According to the solution of the present embodiment, the first guide device 310 and the second guide device 120 can be configured such that when the top end of the vertical beam 300 is accommodated in the notch 111, the guide protrusion 121 of the second guide device 120 can be inserted into the guide groove 311 of the first guide device 310, thereby further preventing the cold air in the storage chamber 110 from leaking from the top end of the vertical beam 300, and improving a sealing effect of the vertical beam 300.

[0039] The guide groove 311 is arc-shaped, and an end of the guide groove apart from a rotating shaft of the vertical beam 300 is provided with an opening 312, such that the guide protrusion 121 can be inserted into or withdrawn from the guide groove 311 through the opening 312; when the first door body 210 rotates relative to the refrigerator body 100, the vertical beam 300 is turned over by limiting the guide groove 311 by the guide protrusion 121. The arc shape of the guide groove 311 is configured according to an overturning track of the ver-

tical beam 300, a side wall of the guide groove 311 gradually tapers inwards from the opening 312 along an arc direction, and finally, a closed round end is formed at an end of the guide groove 311.

[0040] According to the solution of the present embodiment, the guide groove 311 is arc-shaped, and the end of the guide groove 311 apart from the vertical beam 300 is provided with the opening 312, such that the guide protrusion 121 can be smoothly inserted into or withdrawn from the guide groove 311 through the opening 312, thus ensuring that when the first door body 210 rotates relative to the refrigerator body 100, the vertical beam 300 is turned over by limiting the guide groove 311 by the guide protrusion 121.

[0041] The guide protrusion 121 has a forward guide tip 122, and the opening 312 of the guide groove 311 has a greater size than the guide tip 122, such that the guide protrusion 121 can be inserted into the guide groove 311.

[0042] When the first door body 210 of the refrigerator 10 is closed, a butt joint is formed between the guide tip 122 of the guide protrusion 121 and the opening 312 of the guide groove 311, and then, the guide protrusion 121 is inserted into the guide groove 311 through the opening 312 along the guide groove 311 to drive the vertical beam 300 to be turned over until the first door body 210 is completely closed, and at this point, the guide protrusion 121 is completely inserted into the guide groove 311, and the vertical beam 300 abuts against the second door body 220 and the refrigerator body 100.

[0043] When the first door body 210 of the refrigerator 10 is opened, the guide protrusion 121 is withdrawn from the opening 312 along the guide groove 311, and drives the vertical beam 300 to be turned over until the guide protrusion 121 is completely separated from the guide groove 311, and at this point, the vertical beam 300 does not rotate any more.

[0044] As shown in FIGS. 6 to 7, according to the solution of the present embodiment, the guide protrusion 121 is provided with the forward guide tip 122, and the size of the opening 312 of the guide groove 311 is set to be greater than the size of the guide tip 122, such that when the first door body 210 of the refrigerator 10 is closed, the butt joint can be guaranteed to be smoothly formed between the guide tip 122 of the guide protrusion 121 and the opening 312 of the guide groove 311, and therefore, the guide protrusion 121 can be smoothly inserted into the guide groove 311, thereby ensuring that the vertical beam 300 can be normally turned over in the closing process of the first door body 210, and thus abut against the second door body 220 to seal the gap between the first door body 210, the second door body 220 and the refrigerator body 100.

[0045] From the guide tip 122, the guide protrusion 121 extends along a plane to form a first sidewall 123 and extends along a cambered surface to form a second sidewall 124, such that the guide groove 311 is guided by the first sidewall 123 and the second sidewall 124.

[0046] In the solution of the present embodiment, from

the guide tip 122, the guide protrusion 121 extends along the plane to form the first sidewall 123 and extends along the cambered surface to form the second sidewall 124, such that the guide groove 311 is guided by the first sidewall 123 and the second sidewall 124, thereby guaranteeing normal overturning of the vertical beam 300.

[0047] FIG. 8 is an exploded view of a vertical beam 300 of a refrigerator 10 according to an embodiment of the present invention. FIG. 9 is a schematic structural diagram of a vertical beam 300 of a refrigerator 10 according to an embodiment of the present invention. FIG. 10 is a partial enlarged view of region C of FIG. 9.

[0048] An accommodating portion 320 is further provided at a side of the vertical beam 300 close to the first door body 210, and the vertical beam 300 may further include a hinge assembly 330 configured to connect the first door body 210 and the vertical beam 300 and having a hinge shaft 331 provided in the accommodating portion 320.

[0049] As shown in FIGS. 6 to 8, an accommodating space is formed inside the vertical beam 300, and generally, the accommodating space can be filled with a foaming material with a heat insulation effect, or the like, to form a foaming layer, so as to improve the heat insulation effect of the vertical beam 300.

[0050] In the solution of the present embodiment, the vertical beam 300 includes the at least one hinge assembly 330, and a number of the hinge assemblies may be set according to actual requirements.

[0051] In some embodiments, the vertical beam 300 may include only one hinge assembly 330. In other embodiments, in addition to the hinge assembly 330 located at an upper portion of the vertical beam 300, the vertical beam 300 may include at least one connecting piece with a hinging function, such that the vertical beam 300 can more smoothly and stably rotate relative to the first door body 210.

[0052] In the solution of the present embodiment, the accommodating portion 320 is further provided on the side of the interior of the vertical beam 300 close to the first door body 210, the vertical beam 300 further includes the hinge assembly 330 for connecting the first door body 210 and the vertical beam 300, and by providing the hinge shaft 331 in the hinge assembly 330 in the accommodating portion 320 on the side close to the first door body 210, a space occupied by the hinge shaft 331 inside the vertical beam 300 is reduced as much as possible while the vertical beam 300 can be guaranteed to normally rotate relative to the first door body 210, such that a larger space inside the vertical beam 300 can be filled with the foaming material, so as to improve the heat insulation effect of the vertical beam 300.

[0053] The hinge shaft 331 may generally include a first shaft portion 332 and a second shaft portion 333. The first shaft portion 332 is slidably provided in the accommodating portion 320 in a longitudinal direction of the vertical beam 300, and a top surface thereof is formed as a cam surface; the second shaft portion 333 is pro-

vided above the first shaft portion 332 and has a lower end surface fitted with the top surface of the first shaft portion 332.

[0054] Further, the hinge assembly 330 may generally include a fixed portion 334. The fixed portion 334 extends from the second shaft portion 333 and is mounted on the side of the first door body 210 apart from the pivoting center of the first door body 210.

[0055] According to the solution of the present embodiment, the first shaft portion 332 and the second shaft portion 333 are slidable along the longitudinal direction of the vertical beam 300, and the contact end surfaces of the first shaft portion 332 and the second shaft portion 333 are configured as the wavy cam surfaces, such that when the vertical beam 300 rotates relative to the fixed portion 334 fixed on one side of the first door body 210 in the process of opening or closing the first door body 210, the upper end surface of the first shaft portion 332 can slide relative to the lower end surface of the second shaft portion 333, thereby guaranteeing the normal overturning of the vertical beam 300 and limiting the vertical beam 300 to a certain extent.

[0056] The hinge assembly 330 may further include a compression spring 335 having one end abutting against a bottom surface of the first shaft portion 332 and the other end abutting against a bottom surface of the accommodating portion 320. The compression spring 335 is in a compressed state when the first shaft portion 332 slides downwards in the longitudinal direction of the vertical beam 300, and in a stretched state when the first shaft portion 332 slides upwards in the longitudinal direction of the vertical beam 300. An elastic force of the compression spring 335 may be set according to gravity of the first shaft portion 332, and a length of the compression spring 335 may be set according to a distance from the bottom surface of the first shaft portion 332 to the bottom surface of the accommodating portion 320, such that the first shaft portion 332 may slide upwards in the longitudinal direction of the vertical beam 300 under the action of the elastic force of the compression spring 335.

[0057] In the solution of the present embodiment, when the first door body 210 is opened or closed, the first guide device 310 and the second guide device 120 are fitted for guidance, and under the action of a guide force, the vertical beam 300 is turned over relative to the fixed portion 334 fixed on the first door body 210, such that the second shaft portion 333 connected with the fixed portion 334 rotates along the cam surface relative to the first shaft portion 332, and further drives the first shaft portion 332 to move downwards along the cam surface, and when the first shaft portion 332 rotates to a lowest point of the cam surface and continuously rotates, the first shaft portion 332 moves upwards under the action of the elastic force provided by the compression spring 335 and rotates under the action of the cam surface.

[0058] After the first door body 210 is opened or closed completely, the first guide device 310 and the second guide device 120 are released from the fitted state, the

guide force for rotating the vertical beam 300 relative to the fixed portion 334 is not provided any more, the fixed portion 334 cannot continuously drive the second shaft portion 333 to rotate relative to the first shaft portion 332, the first shaft portion 332 is restored to the fitted state of being matched with the lower end surface of the second shaft portion 333 under the action of the elastic force provided by the compression spring 335, and then, the vertical beam 300 is limited, such that an overturning angle of the vertical beam 300 relative to the first door body 210 can be kept normal, and therefore, the first guide device 310 and the second guide device 120 can be conveniently fitted for guidance in the subsequent opening and closing process of the first door body 210, and the vertical beam 300 can be guaranteed to be turned over normally.

[0059] The storage chamber 110 is configured as a freezing compartment; the refrigerator body 100 is further provided with a refrigerating compartment with a front opening, a refrigerating door is provided at the opening of the refrigerating compartment, and a refrigerating vertical beam is rotatably mounted on the refrigerating door; the vertical beam 300 of the freezing compartment has a greater thickness than the refrigerating vertical beam of the refrigerating compartment.

[0060] As is well known to those skilled in the art, a temperature in the refrigerating compartment generally ranges from 2°C to 10°C, preferably from 4 °C to 7 °C. A temperature in the freezing compartment generally ranges from -22°C to -14°C. Different types of items have different optimum storage temperatures and different locations suitable for storage, and for example, fruit and vegetable foods are suitable for storage in the refrigerating compartment and meat foods are suitable for storage in the freezing compartment.

[0061] In the solution of the present embodiment, the refrigerator body 100 of the refrigerator 10 may be provided with one or more storage chambers 110.

[0062] In some embodiments, the refrigerator body 100 of the refrigerator 10 may be provided with two storage chambers 110, the two storage chambers 110 may be configured as a freezing compartment for freezing and a refrigerating compartment for refrigerating respectively, the refrigerating compartment and the freezing compartment may be arranged up and down in a longitudinal direction of the refrigerator 10, and the refrigerating compartment may be located above the freezing compartment. Since the temperature in the freezing compartment is much lower than the temperature in the refrigerating compartment, and an interior and an exterior of the freezing compartment have a larger temperature difference, in order to achieve a better refrigerating effect in the freezing compartment of the refrigerator 10, the heat insulation effect of the vertical beam 300 is required to be further improved.

[0063] According to the solution of the present embodiment, the thickness of the vertical beam 300 at the freezing compartment is particularly set to be greater than the

thickness of the refrigerating vertical beam at the refrigerating compartment, and by increasing the thickness of the vertical beam 300 at the freezing compartment, the accommodating space in the vertical beam 300 is larger and can be filled with more foaming materials, thus improving the heat insulation effect of the vertical beam 300 at the freezing compartment, and improving the refrigerating effect of the freezing compartment of the refrigerator 10.

[0064] In other embodiments, the refrigerator body 100 of the refrigerator 10 may also be provided with only one storage chamber 110, and the storage chamber 110 may be configured as a refrigerating compartment or a freezing compartment, and may be specifically configured according to actual requirements.

[0065] When the storage chamber 110 of the refrigerator 10 is configured as a freezing compartment, the vertical beam 300 on the side-by-side door body assembly 200 at the opening of the freezing compartment has a large thickness to improve the heat insulation effect of the vertical beam 300. When the storage chamber 110 of the refrigerator 10 is configured as a refrigerating compartment, the refrigerating vertical beam on the refrigerating door at the opening of the refrigerating compartment has a small thickness, such that a cost of the refrigerating vertical beam is reduced while a heat preservation requirement of the refrigerating compartment is met.

[0066] A freezing compartment in a traditional refrigerator is generally in a drawer-type structure. However, a sliding rail of a drawer in the freezing compartment is prone to deformation due to long-term pressing in a long-term working process, such that the drawer cannot be normally closed, thus influencing normal use by a user. Furthermore, the drawer-type structure limits a size of a storage object in a height direction, such that many storage objects with large sizes cannot be placed into the freezing compartment, and since a space in the drawer is configured as a whole space which cannot be divided, the space in the drawer has a low utilization rate, and a plurality of storage objects are often stacked together disorderly, thus greatly influencing the use experience of the user.

[0067] According to the solution of the present embodiment, the side-by-side door body assembly 200 is provided at the freezing compartment of the refrigerator 10, and the vertical beam 300 is provided on the first door body 210 of the side-by-side door body assembly 200, such that the size limitation of the freezing compartment on the storage objects is removed on the premise that the refrigerating effect of the freezing compartment of the refrigerator 10 is guaranteed, the space utilization rate of the freezing compartment is improved, and the use experience of the user is further improved.

[0068] Further, in other embodiments, when the storage chamber 110 is configured as a freezing compartment, one or more detachable partitions may be further provided in the freezing compartment, and the user may

adjust the partitions according to actual needs and divide the space in the freezing compartment, such that various storage objects may be orderly stored in the freezing compartment, thereby greatly improving the space utilization rate of the freezing compartment and further improving the use experience of the user.

[0069] Further, according to the solution of the present embodiment, the thicknesses of the vertical beams 300 at the storage chambers 110 with different functions are matched with the functions of the storage chambers 110, thereby further improving the heat insulation effect of the vertical beam 300 and the refrigerating effect of the refrigerator 10.

[0070] So far, it should be appreciated by those skilled in the art that while various exemplary embodiments of the invention have been shown and described in detail herein, many other variations or modifications which are consistent with the principles of this invention may be determined or derived directly from the disclosure of the present invention without departing from the spirit and scope of the invention. Accordingly, the scope of the invention should be understood and interpreted to cover all such other variations or modifications.

Claims

1. A refrigerator, comprising:

a refrigerator body comprising a storage chamber having a front opening;
 a side-by-side door body assembly comprising a first door body and a second door body pivotably provided on both sides of the front opening respectively, so as to open or close the storage chamber;
 a vertical beam rotatably mounted on a side of the first door body apart from a pivoting center of the first door body, and abutting against the second door body when the first door body and the second door body are closed, so as to close a gap among the first door body, the second door body and the refrigerator body;
 wherein a notch is formed at a position of a front end of a top wall of the storage chamber opposite to the vertical beam, and a top end of the vertical beam is accommodated in the notch when abutting against the refrigerator body.

2. The refrigerator according to claim 1, wherein a first guide device and a second guide device are provided at the top end of the vertical beam and an inner side of the top wall of the storage chamber respectively, such that the vertical beam is turned over when entering or exiting from the notch.

3. The refrigerator according to claim 2, wherein the first guide device is configured as a guide groove;

the second guide device is configured as a guide protrusion; and the guide protrusion is inserted into the guide groove when the top end of the vertical beam is received in the notch.

4. The refrigerator according to claim 3, wherein the guide groove is arc-shaped, and an end of the guide groove apart from a rotating shaft of the vertical beam is provided with an opening, such that the guide protrusion can be inserted into or withdrawn from the guide groove through the opening; when the first door body rotates relative to the refrigerator body, the vertical beam is turned over by limiting the guide groove by the guide protrusion.

5. The refrigerator according to claim 4, wherein the guide protrusion has a forward guide tip, and the opening of the guide groove has a greater size than the guide tip, such that the guide protrusion can be inserted into the guide groove.

6. The refrigerator according to claim 5, wherein from the guide tip, the guide protrusion extends along a plane to form a first sidewall and extends along a cambered surface to form a second sidewall, such that the guide groove is guided by the first sidewall and the second sidewall.

7. The refrigerator according to claim 1, wherein an accommodating portion is further provided on a side of the vertical beam close to the first door body, and the vertical beam further comprises:
 a hinge assembly configured to connect the first door body and the vertical beam and having a hinge shaft provided in the accommodating portion.

8. The refrigerator according to claim 7, wherein the hinge shaft comprises:

a first shaft portion slidably provided in the accommodating portion in a longitudinal direction of the vertical beam, a top surface thereof being formed as a cam surface; and
 a second shaft portion provided above the first shaft portion and having a lower end surface fitted with the top surface of the first shaft portion;
 the hinge assembly further comprises:
 a fixed portion extending from the second shaft portion and mounted on the side of the first door body apart from the pivoting center of the first door body.

9. The refrigerator according to claim 8, wherein the hinge assembly further comprises:
 a compression spring having one end abutting against a bottom surface of the first shaft portion and the other end abutting against a bottom surface of the accommodating portion.

10. The refrigerator according to claim 1, wherein the storage chamber is configured as a freezing compartment; the refrigerator body is further provided with a refrigerating compartment with a front opening, a refrigerating door is provided at the opening of the refrigerating compartment, and a refrigerating vertical beam is rotatably mounted on the refrigerating door; the vertical beam of the freezing compartment has a greater thickness than the refrigerating vertical beam of the refrigerating compartment.

5

10

15

20

25

30

35

40

45

50

55

10

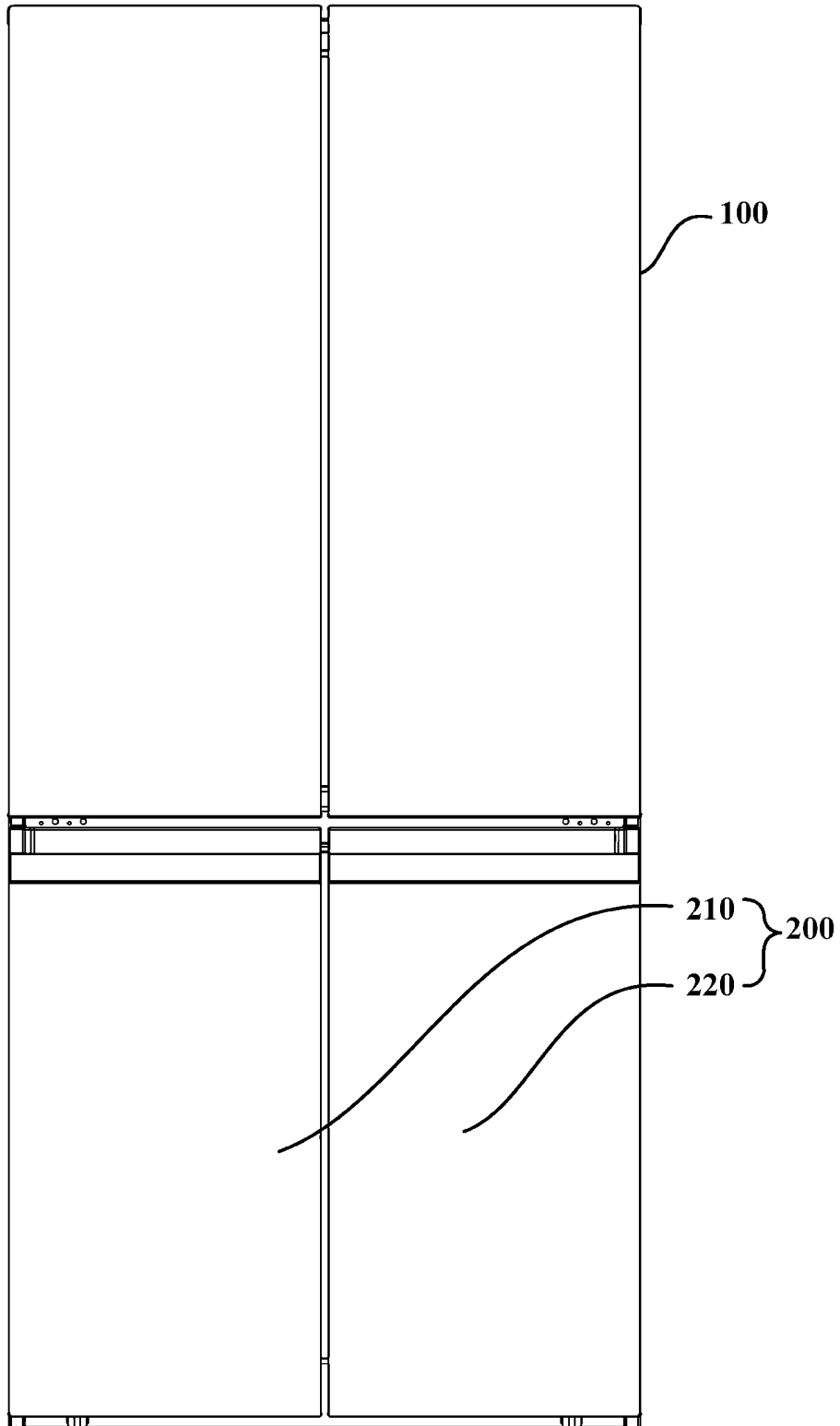

FIG.1

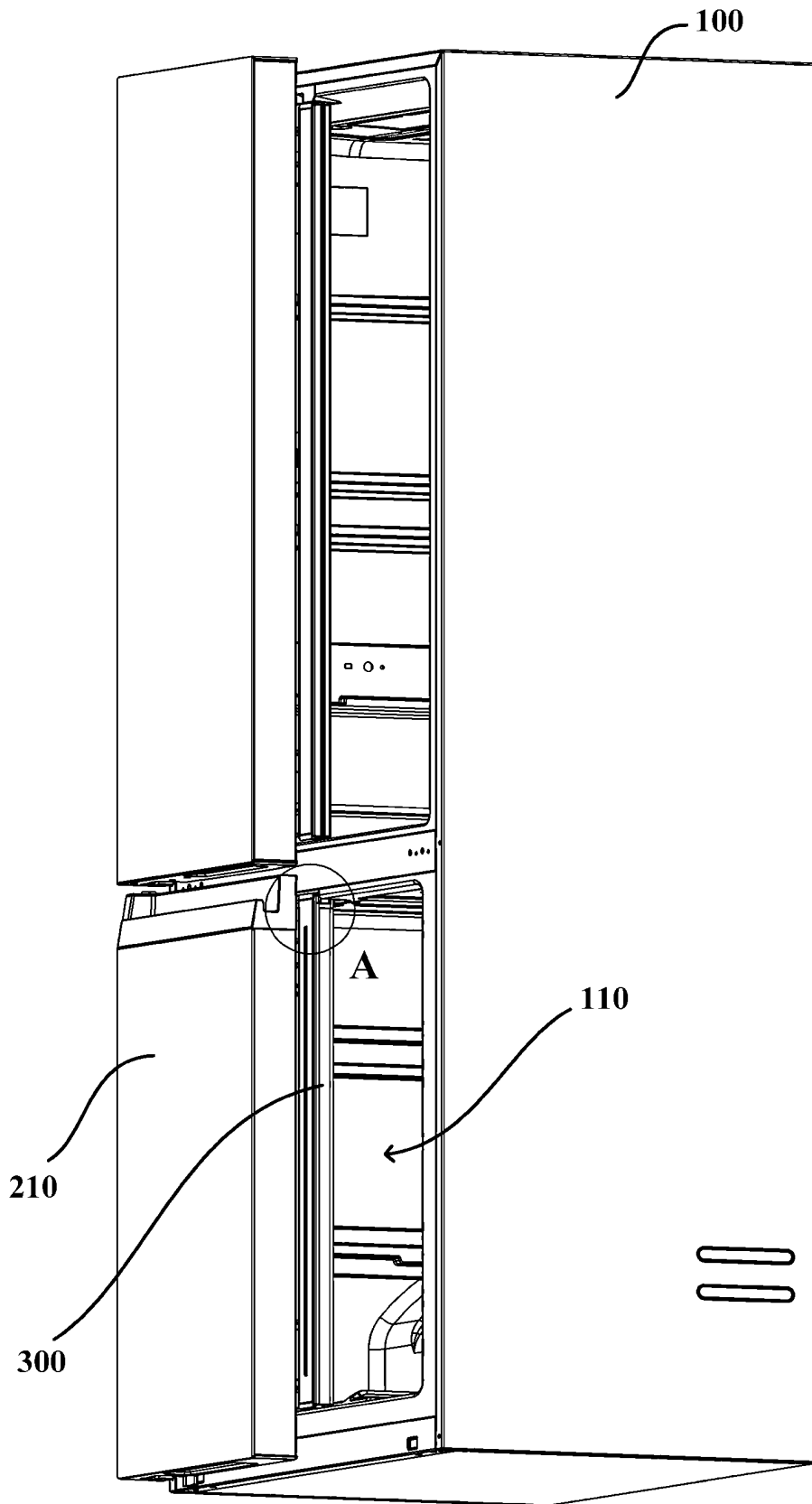

FIG.2

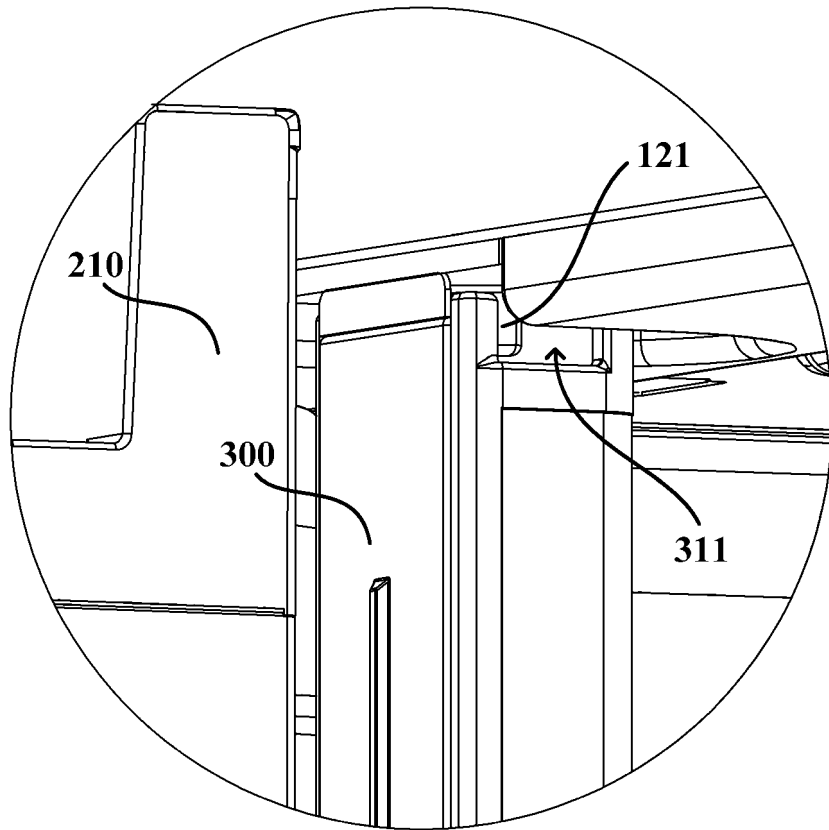

FIG.3

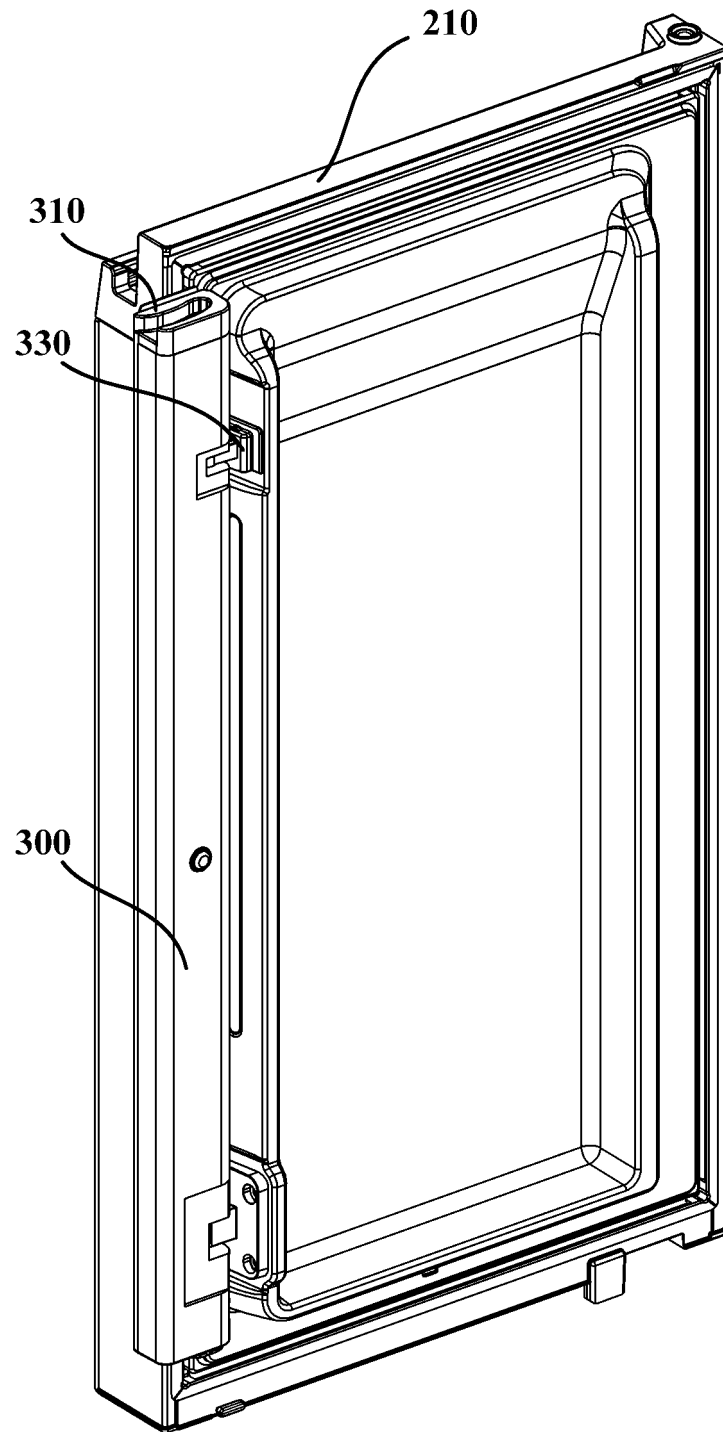

FIG.4

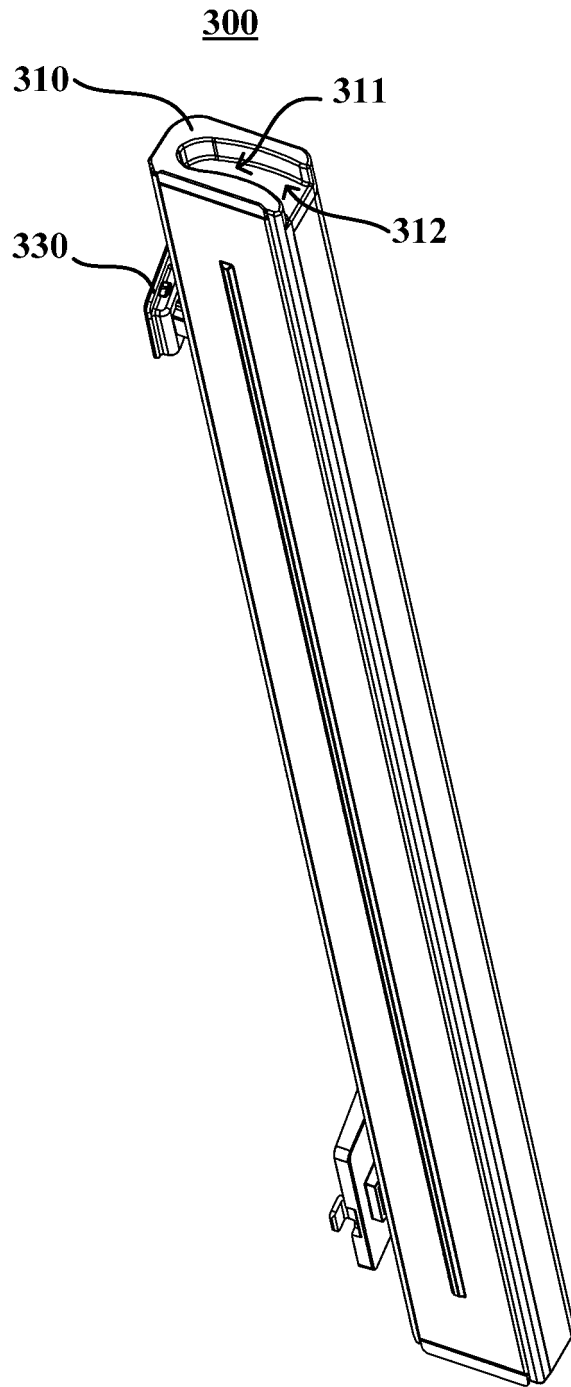

FIG.5

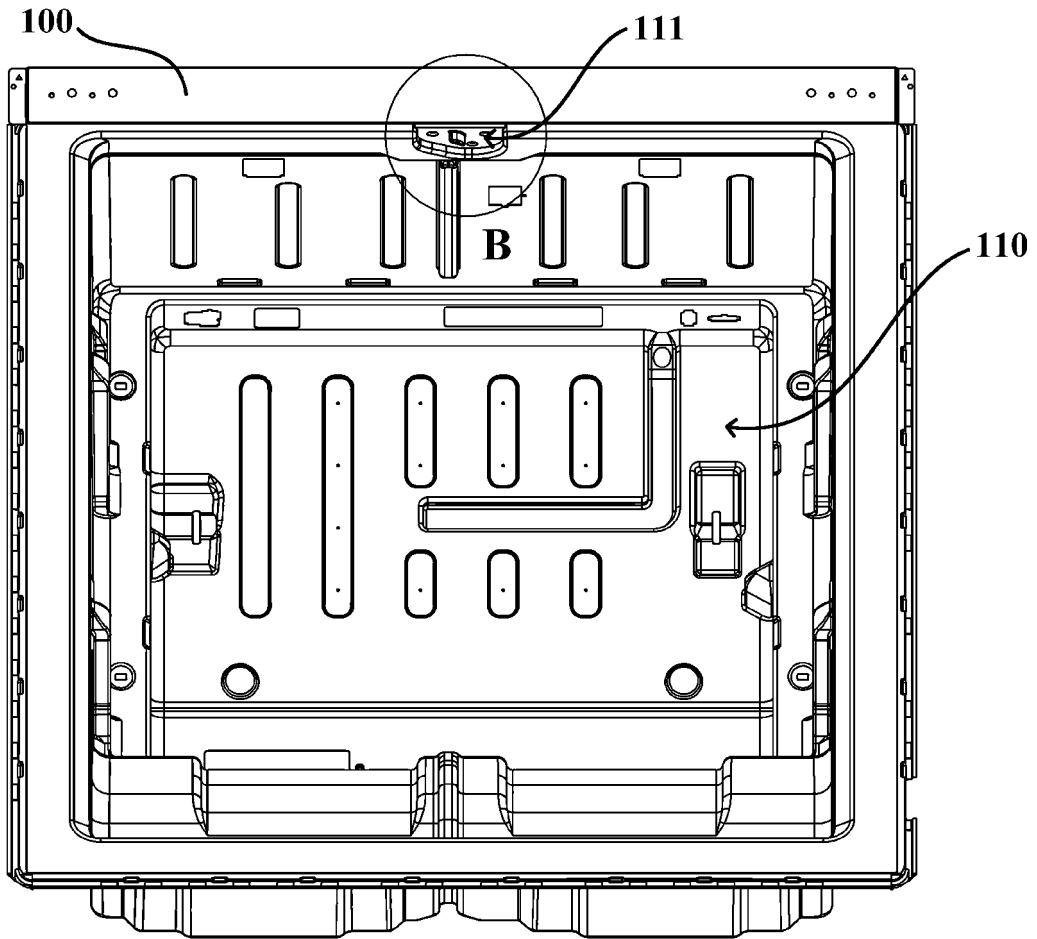

FIG.6

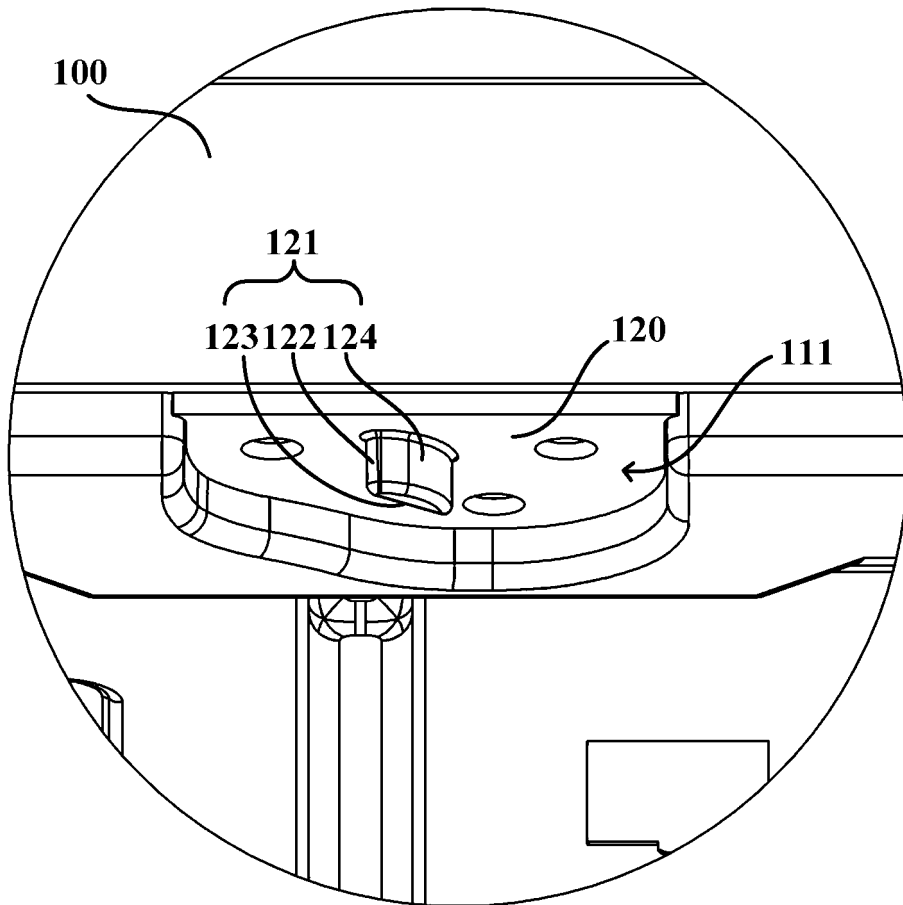

FIG.7

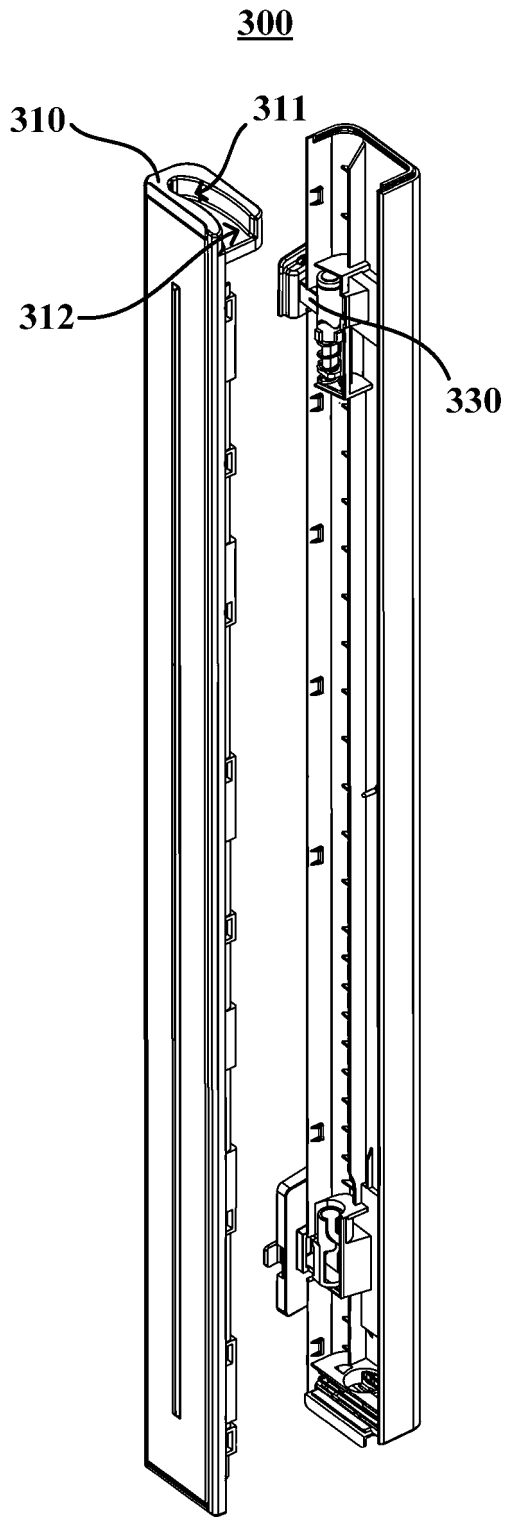

FIG.8

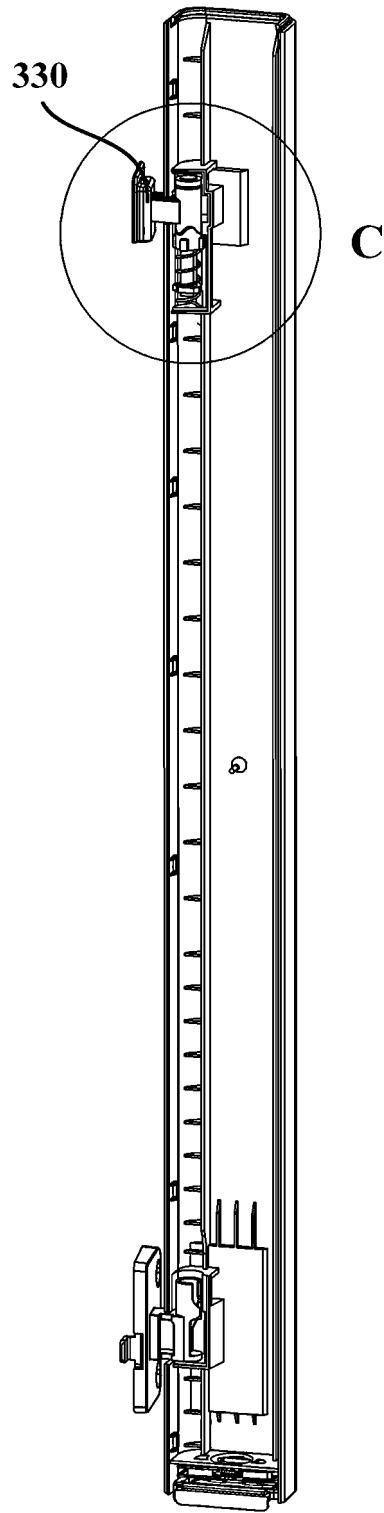

FIG.9

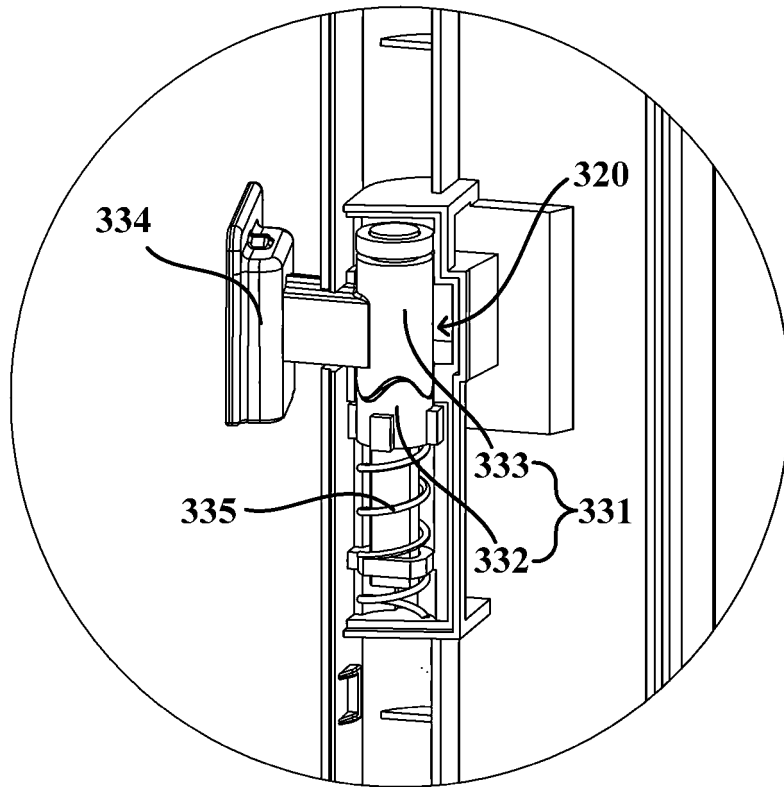

FIG.10

INTERNATIONAL SEARCH REPORT

International application No.

PCT/CN2022/071769

5	A. CLASSIFICATION OF SUBJECT MATTER F25D 23/02(2006.01)i; F25D 11/02(2006.01)i According to International Patent Classification (IPC) or to both national classification and IPC	
10	B. FIELDS SEARCHED Minimum documentation searched (classification system followed by classification symbols) F25D11 F25D23 Documentation searched other than minimum documentation to the extent that such documents are included in the fields searched	
15	Electronic data base consulted during the international search (name of data base and, where practicable, search terms used) CNABS, CNTXT, CNKI, DWPI: 对开门 双开门 法式门 缝隙 间隙 密封 梁 导轨 double french door gap clearance seal+ beam guid+ ax+ shaft spindle	
20	C. DOCUMENTS CONSIDERED TO BE RELEVANT	
	Category*	Citation of document, with indication, where appropriate, of the relevant passages
		Relevant to claim No.
	PX	CN 214892059 U (QINDAO HAIER REFRIGERATOR CO., LTD. et al.) 26 November 2021 (2021-11-26) description, paragraphs [0044]-[0089] and figures 1-10
25	X	CN 111503967 A (HISENSE (SHANDONG) REFRIGERATOR CO., LTD.) 07 August 2020 (2020-08-07) description, paragraphs [0035]-[0060] and figures 4-16
	A	CN 109631460 A (HISENSE (SHANDONG) REFRIGERATOR CO., LTD.) 16 April 2019 (2019-04-16) entire document
30	A	CN 105157329 A (QINGDAO HAIER CO., LTD.) 16 December 2015 (2015-12-16) entire document
	A	WO 2020126471 A1 (ARCELIK AS) 25 June 2020 (2020-06-25) entire document
35	<input type="checkbox"/> Further documents are listed in the continuation of Box C. <input checked="" type="checkbox"/> See patent family annex.	
40	* Special categories of cited documents: "A" document defining the general state of the art which is not considered to be of particular relevance "E" earlier application or patent but published on or after the international filing date "L" document which may throw doubts on priority claim(s) or which is cited to establish the publication date of another citation or other special reason (as specified) "O" document referring to an oral disclosure, use, exhibition or other means "P" document published prior to the international filing date but later than the priority date claimed	"T" later document published after the international filing date or priority date and not in conflict with the application but cited to understand the principle or theory underlying the invention "X" document of particular relevance; the claimed invention cannot be considered novel or cannot be considered to involve an inventive step when the document is taken alone "Y" document of particular relevance; the claimed invention cannot be considered to involve an inventive step when the document is combined with one or more other such documents, such combination being obvious to a person skilled in the art "&" document member of the same patent family
45	Date of the actual completion of the international search 29 March 2022	Date of mailing of the international search report 08 April 2022
50	Name and mailing address of the ISA/CN China National Intellectual Property Administration (ISA/ CN) No. 6, Xitucheng Road, Jimenqiao, Haidian District, Beijing 100088, China Facsimile No. (86-10)62019451	Authorized officer Telephone No.
55		

Form PCT/ISA/210 (second sheet) (January 2015)

INTERNATIONAL SEARCH REPORT
Information on patent family members

International application No.
PCT/CN2022/071769

5
 10
 15
 20
 25
 30
 35
 40
 45
 50
 55

Patent document cited in search report			Publication date (day/month/year)	Patent family member(s)			Publication date (day/month/year)
CN	214892059	U	26 November 2021	None			
CN	111503967	A	07 August 2020	None			
CN	109631460	A	16 April 2019	None			
CN	105157329	A	16 December 2015	None			
WO	2020126471	A1	25 June 2020	EP	3899387	A1	27 October 2021

Form PCT/ISA/210 (patent family annex) (January 2015)