

(19)



(11)

EP 4 311 890 A1

(12)

EUROPEAN PATENT APPLICATION

(43) Date of publication:
31.01.2024 Bulletin 2024/05

(51) International Patent Classification (IPC):
E03F 5/10^(2006.01)

(21) Application number: **23187321.7**

(52) Cooperative Patent Classification (CPC):
E03F 5/10; E03F 5/14

(22) Date of filing: **24.07.2023**

(84) Designated Contracting States:
AL AT BE BG CH CY CZ DE DK EE ES FI FR GB GR HR HU IE IS IT LI LT LU LV MC ME MK MT NL NO PL PT RO RS SE SI SK SM TR
 Designated Extension States:
BA
 Designated Validation States:
KH MA MD TN

- **Laurila, Veijo**
90250 Oulu (FI)

(72) Inventors:

- **Vuokila, Kyösti**
000390 Helsinki (FI)
- **Kangastie, Tarmo**
62900 Alajärvi (FI)
- **Laurila, Veijo**
90250 Oulu (FI)

(30) Priority: **26.07.2022 FI 20225691**

(71) Applicants:

- **Vuokila, Kyösti**
000390 Helsinki (FI)
- **Kangastie, Tarmo**
62900 Alajärvi (FI)

(74) Representative: **Laine IP Oy**
Porkkalankatu 24
00180 Helsinki (FI)

(54) **A DETENTION WELL AND METHOD FOR USING IT**

(57) A novel detention well having a reservoir (1) comprising an inlet conduit (4) and an outlet conduit (5) having a discharge flow opening (8) is disclosed. The detention well is provided with a cleaning apparatus (9) having a float (27) arranged in the reservoir (1), a cleaning means (23) arranged to be movable over the discharge flow opening (8), and power transmission means (15, 16, 25) for transmitting the movement of the float (27) to the cleaning means (23).

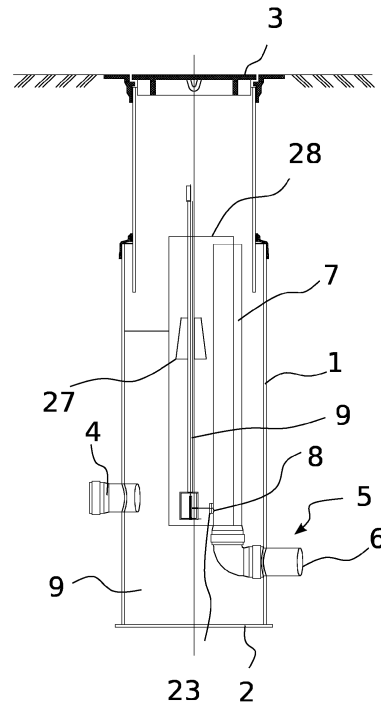

FIG. 1

EP 4 311 890 A1

Description

TECHNICAL FIELD

[0001] The present invention relates to structures used in real estates and municipal engineering. In particular, the invention relates to detention wells used for storm-water drainage. In more detail, the invention relates to a detention well according to the preamble of claim 1 having a discharge opening cleaning system.

BACKGROUND

[0002] A detention well is a reservoir structure preventing flooding of rainwater drains by slowing down the flow rate. Such a well comprises a reservoir with an inlet conduit for receiving water and a discharge conduit for slow removal of water. The discharge conduit is usually carried out as an overflow pipe, the end of which forming the overflow being at a certain height from the bottom of the reservoir. The discharge flow opening is provided in the overflow pipe at a small distance from the bottom of the reservoir. The discharge flow opening is dimensioned so that the water is discharged from the reservoir slowly enough, that is, the dimensioning of the opening adjusts the discharge flow and the detention of water in the reservoir. The reservoir comprises, for example, 110mm inlet and discharge conduits, and the pipe of the discharge conduit is provided with an overflow pipe in case of the reservoir being filled. The detention well is connected, for example, to a rainwater pipe from a gutter or rainwater well before municipal pipe network. During heavy rainfall, the detention well begins to fill up and delay the flow of water, and after rain, the well is slowly emptied.

[0003] Due to the frequent presence of debris in storm-water, such as plastic films, leaves of trees and the like, the discharge flow opening can easily be blocked. Thus, in order to avoid blockage, the discharge flow opening must often be dimensioned larger than providing a sufficiently small outflow and detention would require.

SUMMARY

[0004] The present invention relates to a detention well having a cleaning apparatus to keep the discharge opening unobstructed. The cleaning apparatus is operated by means of a weighted float and it comprises a transmission device for conveying the motion of the float to the cleaning means.

[0005] According to one feature of the invention, the detention well comprises a reservoir having an inlet conduit, an outlet conduit provided with a discharge flow opening. The detention well is further provided with a cleaning apparatus having a float arranged in the reservoir, a cleaning means arranged to be movable over the discharge flow opening, and transmission means for transmitting the float movement to the cleaning means.

[0006] According to another feature of the invention,

the transmission means comprises a rope connected to a float, a pulley over which the rope is arranged to run, and a pulley shaft having a cleaning means arranged at one end thereof.

[0007] According to the third feature of the invention the transmission means comprises a gear rack and a sprocket.

[0008] According to the fourth feature of the invention, the means elements comprises a threaded rod and a helical gear.

[0009] According to the fifth feature of the invention the transmission means comprises a guide and a moving means of the cleaning means moving therein in a controlled way.

[0010] According to a sixth feature of the invention, the discharge duct is provided with an overflow pipe and the parts of the rope and pulley of the cleaning apparatus being below the water level determined by the discharge conduit are enclosed.

[0011] According to the fourth feature of the invention, the transmission means comprise a return spring.

[0012] According to the eighth feature of the invention, a protective tube parallel with the overflow pipe is attached to the overflow pipe, the lower end of which extends to below the discharge flow opening and the upper end to above the overflow pipe.

[0013] More specifically, the invention is characterized by what is disclosed in the characterizing parts of independent claims.

BRIEF DESCRIPTION OF DRAWINGS

[0014] In the following, some embodiments of the invention are disclosed in more detail by means of reference to the appended drawings, in which:

- FIGURE 1 is a partial cross-section of a detention well according to at least one embodiment;
- FIGURE 2 is a cross-sectional view of the detention well of FIGURE 1;
- FIGURE 3 is the detention well cleaning apparatus of figure 1, and
- FIGURE 4 is another view of the apparatus of figure 3.

EMBODIMENTS

[0015] The purpose of detention wells is to achieve a sufficiently long detention of water in the reservoir before the water is led to municipal or other drainage network. For this, the discharge flow must be sufficiently small, especially with low-capacity detention wells. Since the discharge flow is limited by the dimensioning of the discharge flow opening, in practice by the dimensioning of the diameter thereof, a small flow can only be reached by means of a small opening diameter. It is obvious that if the opening has to be very small, the risk of blockage increases when water, such as stormwater, containing solids and debris is treated. Often an opening diameter

of even 5 to 10 mm would be required. With such an opening, the risk of blockage is high and thus the need for maintenance increases due to the need of monitoring operational condition and cleaning work. In order to keep the discharge flow opening clean, here a cleaning apparatus is arranged, the operation of which is based on a cleaning means running over the cleaning opening, the cleaning means being moved by the float. As the water level in the detention well rises and falls, the float moving with the water level provides the power to move the cleaning means without an external actuator. Various brushes, scrapers or scraper combs can be used as the cleaner.

[0016] FIGURE 1 illustrates a detention well. The detention well body is formed by reservoir 1, in this case comprising a cylindrical tube closed at its bottom end by bottom 2. In this example, the upper end of reservoir 1 is closed by telescopic cover 3. Since the structure of the lid of the detention well has no effect on the operation of the cleaning apparatus, the telescopic cover 3 is not described in more detail here. Inlet conduit 4 is formed on the wall of reservoir 1, dimensioned according to the water supply system. In practice, standard dimensions for water pipelines are used here. Inlet conduit 1 is arranged at a distance from the bottom. Exhaust conduit 5 is also formed by a pipe on the wall of the reservoir 1. The part of it extending outside the reservoir 1 forms a connector 6 for connection to the receiving system, for example the municipal storm water network. Inside the reservoir 1, the discharge conduit turns towards the top of reservoir 1 (telescopic cover 3) to form the overflow pipe 7. The end of the discharge conduit 5 inside the reservoir is open and forms the end of the overflow pipe 7, determining the highest water level in the reservoir. The discharge end of the discharge conduit (connector 6) is arranged lower than the input conduit 4. A discharge flow opening 8 has been arranged on the part of overflow pipe 7 of the discharge conduit 5. The discharge flow opening 8 is below the bottom edge of the inlet conduit 4 and thus determines the lowest level of the surface of the water in the reservoir. A sludge chamber 9 is formed between this lowest level and the bottom 2 of the reservoir 1 for the solids accumulating in the reservoir.

[0017] FIGURE 2 is a cross sectional view of the detention well of Figure 1.

[0018] FIGURES 3 and 4 show the discharge flow opening cleaning apparatus 9. The cleaning apparatus 9 comprises a body 10 formed by a base 11, a cover 12 and a spacer 13. Spacer 13 is shown more clearly in FIGURE 3. It is provided with a slot 14 into which a pulley 15 is arranged. Shaft 16 passes through the pulley 15, with a groove 17 formed for the shaft in the cover 12 and an shaft hole 18 in the bottom. The shaft 15 thus extends through the bottom 11 and is supported in the opening 14 centrally by groove 17 and the shaft hole 18. The shaft 16 and the pulley 15 are thus arranged inside the body 10 so that they can rotate freely therein. The spacer 13 is provided with two parallel rope holes 19 oriented approximately parallel to the tangent of the pulley 15 and

arranged on both sides of the shaft 16, having adapters 20 for rope pipes 21 and spring pipe 22 at the outer end of the body 10 thereof. These pipes are, for example, made of aluminium, which is very resistant to humid conditions. Polymers and stainless or even acid-proof stainless steel could alternative materials, if necessary.

[0019] FIGURE 1 shows that the cleaning apparatus 9 is arranged in the detention well so that the end of the shaft 16 is aligned with the discharge flow opening. At the end of the shaft 16 a cleaning means 23 is provided, which may be a brush, a scraper or a comb scraper or other similar arrangement that can be moved over the discharge opening by suitably moving it. When connected to the shaft 16, the cleaning means is rotated. The shaft 16 can be arranged centrally on or slightly to the side of the discharge flow opening so that the cleaning means sweeps from the side over the discharge flow opening. The lengths of the rope pipe 21 and the spring pipe 22 are dimensioned so that they extend above the highest water level determined by the end of the overflow pipe 7. Thus, the mechanics of the cleaning apparatus is protected from debris that could obstruct its operation. The structure does not have to be waterproof.

[0020] The return spring 24 is arranged in the spring pipe 22, provided with a rope 25 running initially in the spring pipe 22. The rope 25 runs around the pulley 15 at the end of the rope pipe 21 and to the idler pulley 26. From the idler wheel 26 the rope goes to the float 27, suspended by the rope 25 around the rope pipe. The float 27 is hollow or made of a material lighter than water material. In addition, if necessary, it has a weight or weights to adjust the buoyancy so as to provide sufficient pulling power for the return spring.

[0021] The cleaning apparatus works in such a way that when the water level in the reservoir 1 rises, the water causes the float to rise upwards and the return spring pulls the rope 25 around the pulley 15. Now the cleaning means 23 rotates in relation to the discharge flow opening and removes any debris and algae and such accumulations. Correspondingly, as the water level drops, the float 27 follows the water level, pulling the rope 25 out of the rope pipe and the cleaning means 23 rotates. By means of this arrangement, the movement of the cleaning is easy to implement by means of the float. Due to the large differences in the height of the water surface, the travel of the float is large, whereby a mechanism providing sufficient travel is needed. This is preferably implemented by means of rope and pulleys. In addition, encasing the system is easy, as seen in the example above.

[0022] Alternative transmission elements could include gear racks and cogs, threaded rods and helical gears and similar arrangements, where the rods and racks would replace the rope and pulleys or a toothed shaft would replace the pulley. Transmission means could comprise a guide and a cleaning means moving apparatus moving controllably thereon, such as for example a rail and a slider moving thereon. Even a solution

where a rope or the like connected to a float runs through guide rings to the cleaning means, with a return spring attached to the opposite side of the cleaning means, the spring being a coil spring, could be considered. The coil spring could also be used in other alternative solutions. A counterweight could possibly be used instead of a return spring.

[0023] If the shaft 16 is positioned centrally with the discharge flow opening 8, a reciprocal movement can be arranged for the shaft by means of, for example, an external thread, a releasing tongue running along it and a counter-spring. This movement can be used to enhance the operation of the cleaning means or it can be dimensioned to adjust the flow at the discharge flow opening. For example, with a shaft having an initially conical head, the opening could be adjusted so that its size increases when the float is high (volume of water is large) and decreases when the volume of water decreases and its surface is lowered.

[0024] A protective tube 28 is arranged parallel to the overflow pipe 7. The protective tube 28 is a tube-like arc or a U-shaped tube arc formed by cutting the tube wall longitudinally open and then fixed longitudinally along open edges to the overflow pipe 7. The tube arc of the protective tube 28 surrounds the cleaning equipment so that the lower end of the protective tube 28 extends at least below the discharge flow opening 8 and most preferably below the structure of the cleaning equipment. Thus it prevents debris from entering the discharge flow opening 8 and the cleaning equipment as long as the water level remains below the discharge flow opening, as it does under normal operating conditions. The water level will sink below it only when the well dries up. Correspondingly, the upper end of the protective tube 28 is higher than the upper end of the overflow pipe, thus preventing debris from entering the operating means of the cleaning equipment and the discharge opening 8 via the surface of the water when the water is high.

INDUSTRIAL APPLICABILITY

[0025] The invention can be used to implement storm-water systems.

LIST OF REFERENCE NUMBERS

[0026]

1	reservoir
2	bottom
3	telescopic cover
4	inlet conduit
5	outlet conduit
6	connector
7	overflow pipe
8	discharge flow opening
9	cleaning apparatus
10	body

11	bottom
12	7 cover
13	spacer
14	slot
5 15	pulley
16.	shaft
17.	groove
18	axle hole
19	rope hole
10 20	adapter
21	string pipe
22	spring pipe
23	cleaning means
24	return spring
15 25	rope
26.	idler pulley
27	float
28	protective tube

20 Claims

1. Detention well having a reservoir (1) comprising an inlet conduit (4) and an outlet conduit (5) having a discharge flow opening (8) arranged thereto, **characterized by** a cleaning apparatus (9) having a float (27) arranged in the reservoir (1), a cleaning means (23) arranged movably over the discharge flow opening (8) and power transmission means (15, 16, 25) for transmitting the movement of the float (27) to the cleaning apparatus (23).
2. A detention well according to claim 1, **characterized in that** the transmission means comprises a rope (25) connected to the float (27), a pulley (15) over which the rope (25) is arranged to run, and a pulley (15) shaft (16) having a cleaning apparatus (23) arranged at one end thereof.
3. A detention well according to claim 1, **characterized in that** the transmission means comprises a gear rack and a cog.
4. A detention well according to claim 1, **characterized in that** the transmission means comprises a threaded rod and a helical gear.
5. A detention well according to claim 1, **characterized in that** the transmission means comprises a guide and a moving means of the cleaning means moving therein in a controlled way.
6. A detention well according to any of the preceding claims 1 to 2, **characterized in that** the discharge conduit (5) is provided with an overflow pipe (7) and the parts of the rope (25) and the pulley (15) of the cleaning apparatus being below the water level determined by the discharge conduit (7) are enclosed.

7. A detention well according to any of the preceding claims, **characterized in that** the transmission means comprises a return spring (25).

8. A detention well according to claim 8, **characterized in that** a protective tube (28) parallel with the overflow pipe (7) is attached thereto, the lower end of which extends to below the discharge flow opening (8) and the upper end to above the overflow pipe (7).

9. Method for cleaning the discharge flow opening of a detention well having a reservoir (1) comprising an inlet conduit (4) and an outlet conduit (5) having an discharge flow opening (8) arranged thereto, a cleaning apparatus (9) having a float (27) arranged in the reservoir (1), a cleaning means (23) arranged to be moved over the discharge flow opening (8) and power transmission means (15, 16, 25) for transmitting the movement of the float (27) to the cleaning apparatus (23), in which method the movement of the float determined by the movement of the surface of the water is directed into movement of the cleaning means.

5

10

15

20

25

30

35

40

45

50

55

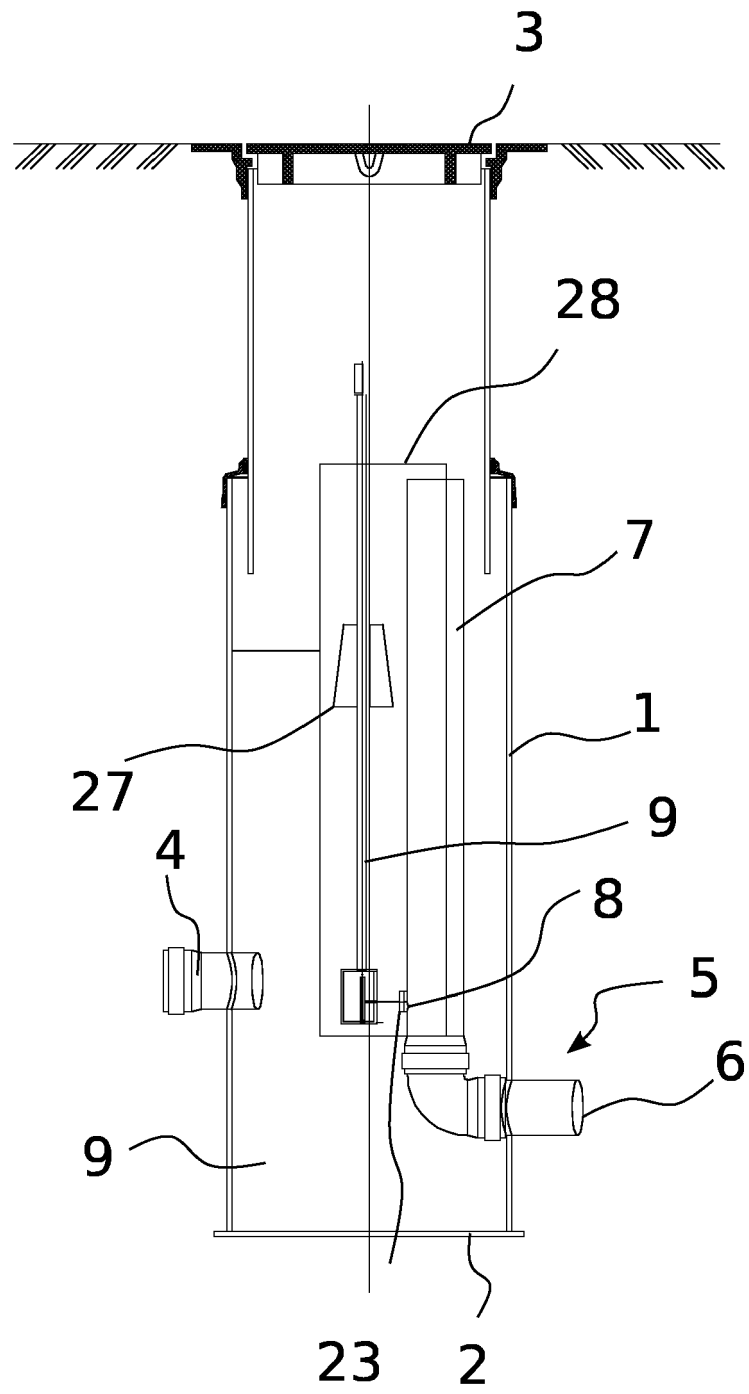

FIG. 1

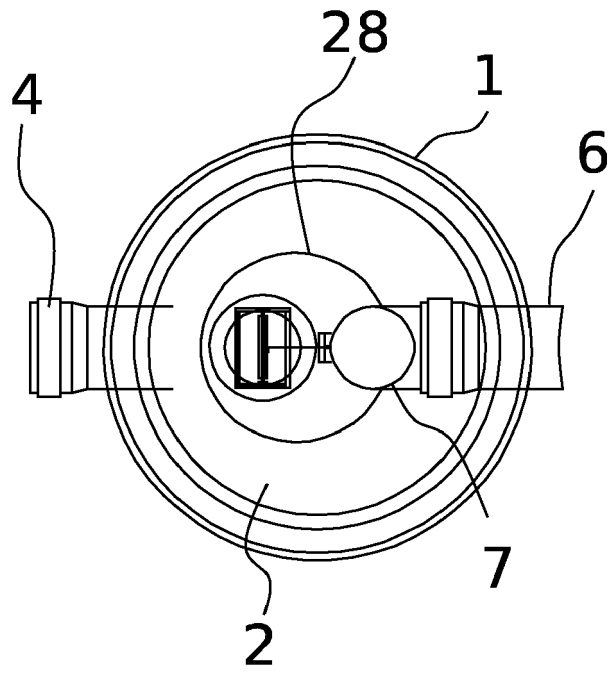

FIG. 2

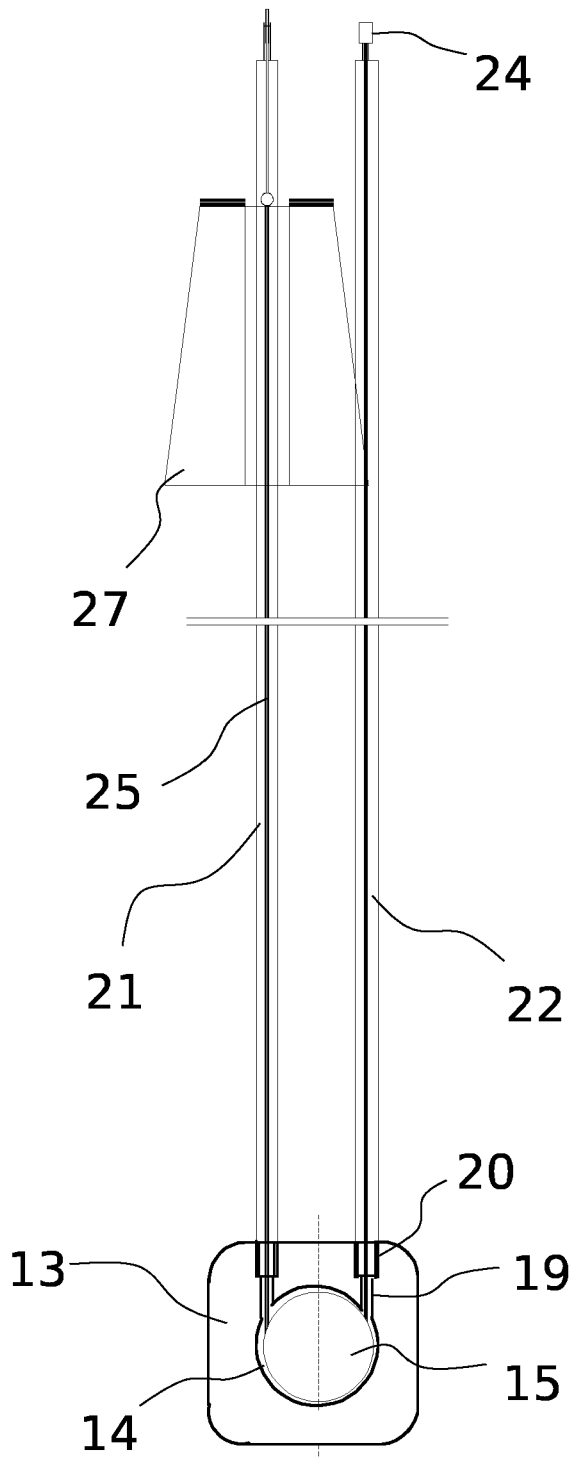

FIG. 3

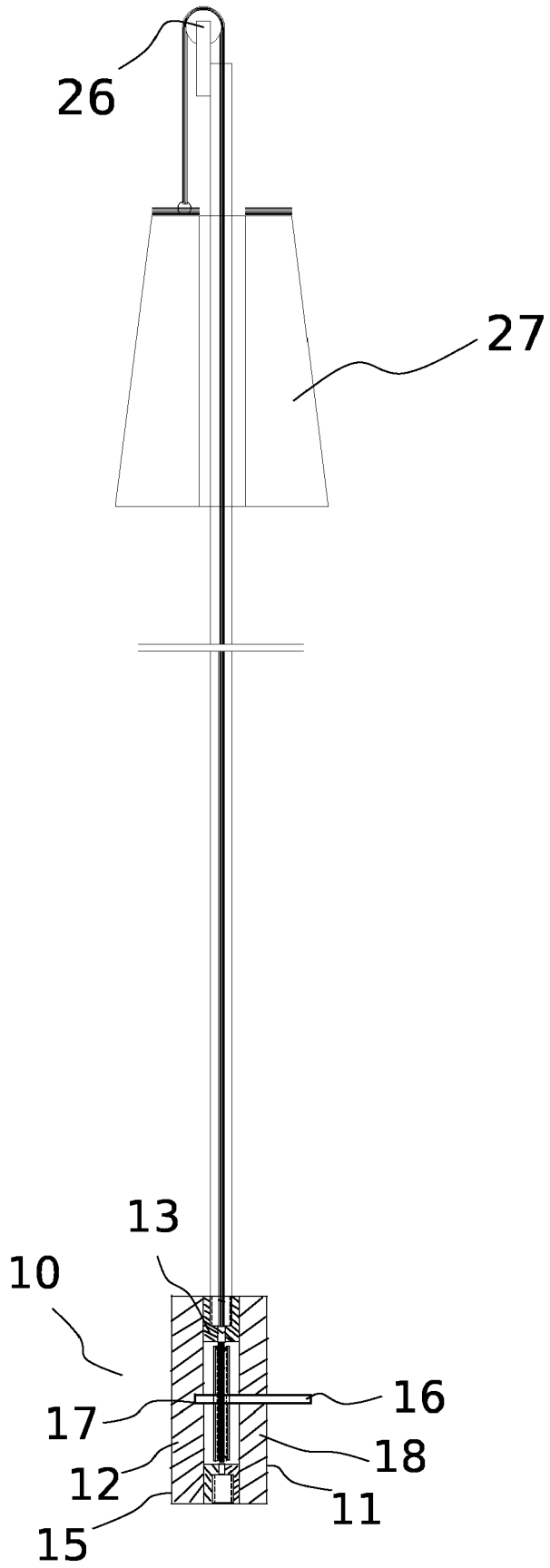

FIG. 4



EUROPEAN SEARCH REPORT

Application Number

EP 23 18 7321

5

10

15

20

25

30

35

40

45

50

55

DOCUMENTS CONSIDERED TO BE RELEVANT			
Category	Citation of document with indication, where appropriate, of relevant passages	Relevant to claim	CLASSIFICATION OF THE APPLICATION (IPC)
X	US 2005/025573 A1 (WALDMAN JOHN JEFFREY [US] ET AL) 3 February 2005 (2005-02-03)	1, 7, 9	INV. E03F5/10
A	* paragraphs [0034], [0035]; figure 7 * -----	2-6, 8	
X	KR 2012 0138545 A (KIM SU JIN [KR]; KIM DONG EON [KR]) 26 December 2012 (2012-12-26)	1, 5, 9	E03F
A	* paragraphs [0017], [0018]; figures 1, 2A * -----	2-4, 6-8	
The present search report has been drawn up for all claims			TECHNICAL FIELDS SEARCHED (IPC)
Place of search		Date of completion of the search	Examiner
Munich		4 December 2023	Flygare, Esa
CATEGORY OF CITED DOCUMENTS			
X : particularly relevant if taken alone Y : particularly relevant if combined with another document of the same category A : technological background O : non-written disclosure P : intermediate document		T : theory or principle underlying the invention E : earlier patent document, but published on, or after the filing date D : document cited in the application L : document cited for other reasons & : member of the same patent family, corresponding document	

1
EPO FORM 1503 03:82 (P04C01)

**ANNEX TO THE EUROPEAN SEARCH REPORT
ON EUROPEAN PATENT APPLICATION NO.**

EP 23 18 7321

5 This annex lists the patent family members relating to the patent documents cited in the above-mentioned European search report.
The members are as contained in the European Patent Office EDP file on
The European Patent Office is in no way liable for these particulars which are merely given for the purpose of information.

04-12-2023

Patent document cited in search report	Publication date	Patent family member(s)	Publication date
US 2005025573 A1	03-02-2005	US 2005025573 A1 WO 2005012660 A1	03-02-2005 10-02-2005
KR 20120138545 A	26-12-2012	NONE	

EPO FORM P0459

For more details about this annex : see Official Journal of the European Patent Office, No. 12/82