



(12) **EUROPEAN PATENT APPLICATION**

(43) Date of publication:
14.02.2024 Bulletin 2024/07

(51) International Patent Classification (IPC):
B65H 54/26 (2006.01) B65H 63/00 (2006.01)
B65H 67/04 (2006.01)

(21) Application number: **23190252.9**

(52) Cooperative Patent Classification (CPC):
B65H 54/26; B65H 63/00; B65H 67/0411

(22) Date of filing: **08.08.2023**

(84) Designated Contracting States:
AL AT BE BG CH CY CZ DE DK EE ES FI FR GB GR HR HU IE IS IT LI LT LU LV MC ME MK MT NL NO PL PT RO RS SE SI SK SM TR
 Designated Extension States:
BA
 Designated Validation States:
KH MA MD TN

(71) Applicant: **Murata Machinery, Ltd.**
Kyoto-shi, Kyoto 601-8326 (JP)

(72) Inventor: **HIRAI, Katsuhisa**
Kyoto-shi, Kyoto 612-8686 (JP)

(74) Representative: **Hoffmann Eitle Patent- und Rechtsanwälte PartmbB**
Arabellastraße 30
81925 München (DE)

(30) Priority: **10.08.2022 JP 2022127701**

(54) **AUTOMATIC WINDER**

(57) An automatic winder includes a plurality of winding units, a doffing device 17, a package conveyor 52, and an operation state display panel 80. The winding unit unwinds a yarn from a yarn supplying bobbin, and winds the unwound yarn to individually form a package. The doffing device 17 removes the package formed by the winding unit. The package conveyor 52 conveys the package doffed by the doffing device 17. The operation

state display panel 80 is provided to the doffing device 17 and the package conveyor 52. The operation state display panel 80 includes a segment display section including a plurality of columns and a plurality of rows of segments. The segment display section of the operation state display panel 80 displays an operation state of at least one of the doffing device 17 or the package conveyor 52, with a regular light-on and light-off pattern.

FIG. 4

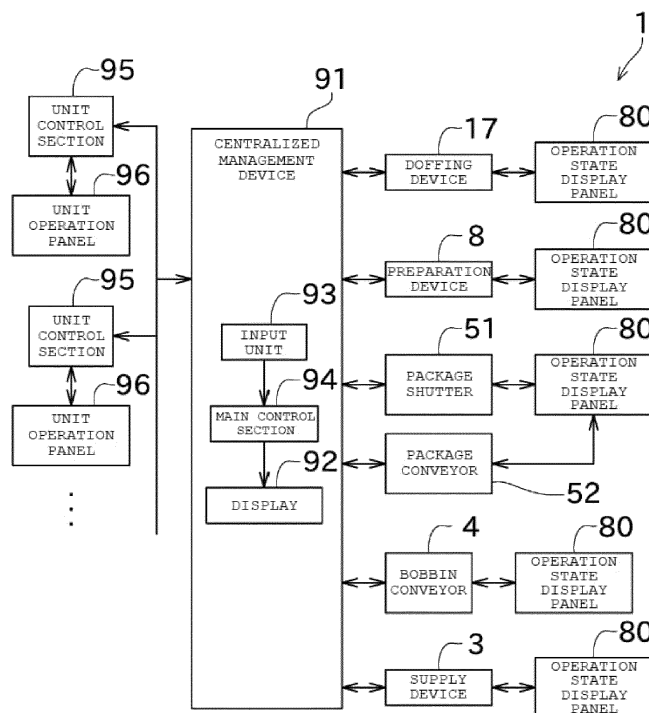

Description

BACKGROUND OF THE INVENTION

1. Field of the Invention

[0001] The present invention relates to an automatic winder. Specifically, the present invention relates to a state display section that displays a state of a device included in the automatic winder.

2. Description of the Related Art

[0002] Patent Document 1 is Japanese Unexamined Patent Publication No. 2010-269915.

[0003] An automatic winder of Patent Document 1 includes a plurality of winding units adapted to wind a yarn of a yarn supplying bobbin to form a package. Each winding unit includes an alarm section that is a lamp or a buzzer. Patent Document 1 discloses, as an abnormality of which the alarm section notifies, a defective rotation of the package, a doffing mistake of a doffing device, and the like.

[0004] In the automatic winder of Patent Document 1, the alarm section is lighted on when an abnormality occurs and the automatic winder is stopped, but the alarm section is lighted off in other states. Therefore, it is not possible to clearly distinguish, for example, whether the doffing device is stopped at some point during a series of doffing work (an operation cycle) or the doffing device is stopped after completion of the series of doffing work. Therefore, an operator is not able to grasp a status of the doffing device at a glance. This problem is not limited to the doffing device, and similar problems also exist in other devices included in the automatic winder, for example, a package conveyor and the like.

BRIEF SUMMARY OF THE INVENTION

[0005] The present invention has been made in view of the above circumstances, and a main object thereof is to provide an automatic winder that allows an operator to easily grasp an operation status of a doffing device or a package conveyor at a glance.

[0006] The problem to be solved by the present invention is as described above, and means for solving the problem and effects thereof will be described next.

[0007] According to an aspect of the present invention, an automatic winder having the following configuration is provided. That is, the automatic winder includes a plurality of winding units, a doffing device, a package conveyor, and an operation state display panel. The winding unit unwinds a yarn from a yarn supplying bobbin, and winds the unwound yarn to individually form a package. The doffing device doffs the package formed by the winding unit. The package conveyor conveys the package doffed by the doffing device. The operation state display panel is provided to the doffing device and the package

conveyor. The operation state display panel includes a segment display section including a plurality of columns and a plurality of rows of segments. The segment display section of the operation state display panel displays an operation state of at least one of the doffing device or the package conveyor, with a regular light-on and light-off pattern.

[0008] Accordingly, the operation state is displayed for at least one of the doffing device or the package conveyor, so that the operator can easily check, for example, whether the target device has temporarily interrupted the operation during work or has stopped after completion of the work.

[0009] In the automatic winder described above, the segment display section of the operation state display panel is preferably a seven-segment display.

[0010] Accordingly, various types of display can be performed while the number of segments is suppressed.

[0011] The automatic winder described above preferably has the following configuration. That is, the winding unit includes a unit operation panel for control of an operation of a device included in the winding unit. The unit operation panel includes a segment display section including a plurality of columns and a plurality of rows of segments. The segment display section of the operation state display panel and the segment display section of the unit operation panel have the same configuration.

[0012] Accordingly, at least some of components can be made common between the unit operation panel and the operation state display panel, so that a cost can be reduced.

[0013] The automatic winder described above preferably has the following configuration. That is, the automatic winder includes a preparation device and a bobbin conveyor. The preparation device performs pre-processing on the yarn supplying bobbin to establish a state where the winding unit is able to process the yarn supplying bobbin. The bobbin conveyor supplies the yarn supplying bobbin pre-processed by the preparation device to the winding unit. The operation state display panel is further provided to at least one of the preparation device or the bobbin conveyor, and the segment display section of the operation state display panel further displays an operation state of at least one of the preparation device or the bobbin conveyor.

[0014] Accordingly, the operation state is displayed for at least one of the preparation device or the bobbin conveyor, so that the operator can easily check, for example, whether the operation is temporarily interrupted during work or is stopped after completion of the work.

[0015] The automatic winder described above preferably has the following configuration. That is, the automatic winder includes a supply device adapted to supply the yarn supplying bobbin to the bobbin conveyor. The operation state display panel is further provided to the supply device, and the segment display section of the operation state display panel further displays an operation state of the supply device.

[0016] Accordingly, the operation state of the supply device is displayed on the operation state display panel, so that the operator can easily check, for example, whether the supply device has temporarily interrupted the operation during work or has stopped after completion of the work.

[0017] The automatic winder described above preferably has the following configuration. That is, the operation state display panel is provided to the package conveyor. The segment display section of the operation state display panel provided to the package conveyor displays an operation state of the package conveyor.

[0018] Accordingly, the operation state of the package conveyor is displayed, so that the operator can easily check, for example, whether the operation is temporarily interrupted during work or is stopped after completion of the work.

[0019] In the automatic winder described above, when the package conveyor is in operation, the segment display section of the operation state display panel provided to the package conveyor preferably performs display in which a lighted portion appears to rotate, by making a difference in timing of lighting on and off for each of the segments.

[0020] Accordingly, a concept is similar between that the package conveyor is operating and that the lighted portion is rotating, so that the operator can intuitively grasp that the package conveyor is operating.

[0021] The automatic winder described above preferably has the following configuration. That is, the automatic winder includes a package shutter capable of switching between: a first state in which the package is able to move from the winding unit to the package conveyor; and a second state in which the package is unable to move from the winding unit to the package conveyor. A single operation state display panel displays an operation state of the package conveyor and an operation state of the package shutter.

[0022] Accordingly, the operation states of the two devices operating in series are displayed on one operation state display panel, so that the operator can grasp the operation states of the two devices operating in series by simply viewing one operation state display panel.

[0023] The automatic winder described above preferably has the following configuration. That is, the automatic winder includes a package shutter capable of switching between: a first state in which the package is able to move from the winding unit to the package conveyor; and a second state in which the package is unable to move from the winding unit to the package conveyor. The segment display section of the operation state display panel that displays the operation state of the package shutter performs display in which a lighted portion appears to vertically move, by making a difference in timing of lighting on and off for each of the segments.

[0024] Accordingly, a concept is similar between that the package shutter is operating and that the lighted portion is vertically moving, so that the operator can intuitively

grasp that the package shutter is operating.

[0025] In the automatic winder described above, when the seven-segment display of the operation state display panel is lighted on in a regular light-on and light-off pattern, the number of segments that are lighted on is preferably identical in the individual patterns.

[0026] Accordingly, a sense of unity can be provided between the individual patterns.

[0027] The automatic winder described above preferably has the following configuration. That is, the segment display section indicates that the target device is operating, by displaying characters "on" by lighting on or off the segments. The segment display section indicates that the target device is stopped, by displaying characters "off" by lighting on or off the segments.

[0028] Accordingly, the operator can grasp whether or not the device is in operation at a glance.

BRIEF DESCRIPTION OF THE DRAWINGS

[0029]

FIG. 1 is a schematic plan view of an automatic winder according to an embodiment of the present invention;

FIG. 2 is a front view illustrating an overall configuration of the automatic winder;

FIG. 3 is a perspective view illustrating a configuration of a package conveyor and a package shutter;

FIG. 4 is a block diagram of an automatic winder main body;

FIG. 5 is a front view of an operation state display panel;

FIG. 6 is a view illustrating that rotation display is performed by lighting on/off each segment of a segment display section;

FIG. 7 is a view illustrating that vertical movement display is performed by lighting on/off each segment of the segment display section; and

FIG. 8 is a view illustrating that on/off display is performed by lighting on/off each segment of the segment display section.

DETAILED DESCRIPTION OF PREFERRED EMBODIMENTS

[0030] Next, an embodiment of the present invention will be described with reference to the drawings.

[0031] An automatic winder 100 illustrated in FIG. 1 includes an automatic winder main body 1, a bobbin preparation system 2, and a supply device 3.

[0032] As illustrated in FIG. 2, the automatic winder main body 1 mainly includes a plurality of winding units 1a arranged side by side, a control box 85, and a doffing device 17. As illustrated in FIG. 1, the automatic winder main body 1 has a bobbin conveyor 4 which is for automatically conveying the yarn supplying bobbin 12 to each winding unit 1a. Each winding unit 1a unwinds a yarn 10

from the yarn supplying bobbin 12, and winds the unwound yarn 10 around a winding tube while traversing, to form a package 15.

[0033] A centralized management device 91 is disposed in the control box 85. The centralized management device 91 can communicate with each winding unit 1a. The centralized management device 91 can centrally manage information on each winding unit 1a and the like. As illustrated in FIG. 2, the centralized management device 91 includes a display 92, an input unit 93, and a main control section 94.

[0034] When appropriately operated by an operator, the display 92 displays an operating status of each winding unit 1a and/or information relating to yarn quality. The input unit 93 has a plurality of input keys. The input unit 93 is used for the operator to select information to be displayed on the display 92. The input unit 93 receives setting about various operating statuses of each winding unit 1a and/or information relating to yarn quality as well as setting about operations of various devices in the automatic winder 100.

[0035] When the package 15 is fully wound (a state where a prescribed amount of the yarn 10 is wound) in one of the plurality of winding units 1a, the doffing device 17 illustrated in FIG. 2 moves to a position corresponding to the relevant winding unit 1a. The doffing device 17 having arrived at the winding unit 1a can automatically remove and doff the fully-wound package 15, and set a new winding tube.

[0036] An operation state display panel 80 is provided on a front side of the doffing device 17. The operation state display panel 80 is used to display an operation state of the doffing device 17. Displaying an operation state means displaying whether or not the doffing device 17 is in operation. The term "in operation" means a period from reception of an operation instruction (or from a start of the operation) to completion. In the case of the doffing device 17, a period from reception of a request for doffing to completion of the doffing work corresponds to the period in operation (at some point in the operation cycle). Further, a case where the doffing device 17 has temporarily interrupted the operation to wait for completion of an operation of another device after the start of the doffing work also corresponds to the period in operation. Therefore, by providing the doffing device 17 with the operation state display panel 80, the operator can easily grasp whether or not the doffing device 17 is in operation (furthermore, whether the operation is temporarily interrupted or the doffing work is stopped after completion). The description of the operation state described above is applied not only to the doffing device 17 but also to other devices described later.

[0037] As illustrated in FIG. 3, the package 15 fully wound by the winding unit 1a is collected by the package conveyor 52. Specifically, the package 15 fully wound and removed by the doffing device 17 moves obliquely downward toward the package conveyor 52 while rolling along a conveyance surface 50.

[0038] Further, the conveyance surface 50 is provided with a package shutter 51. As illustrated in FIG. 3, the package shutter 51 can be switched between a first state (an upper side in FIG. 3) and a second state (a lower side in FIG. 3). In the first state, since the package shutter 51 protrudes with respect to the conveyance surface 50, movement of the package 15 from the winding unit 1a to the package conveyor 52 is inhibited. In the second state, the package shutter 51 is to move downward from the first state, so that the package shutter 51 does not protrude from the conveyance surface 50. As a result, in the second state, movement of the package 15 from the winding unit 1a to the package conveyor 52 is permitted. In the present embodiment, one package shutter 51 is provided for each group including a predetermined number of winding units 1a. However, the package shutter 51 may be provided for each winding unit 1a, or one package shutter 51 may be provided for all the winding units 1a.

[0039] The package conveyor 52 includes a motor, a pulley, and a belt (which are not illustrated), and the belt is moved by driving the pulley with a driving force of the motor. A moving direction of the package conveyor 52 is the same as a parallel direction of the winding units 1a, and is the same as an axial direction of the package 15.

[0040] The package conveyor 52 stops at a timing when the package 15 reaches a predetermined position (for example, an end portion in a conveyance direction) after starting conveyance of the package 15. The operator collects the package 15 placed on the package conveyor 52, and puts the package 15 into a predetermined collection box. The stop timing of the package conveyor 52 may be after a time from driving of the package conveyor 52 to reaching a predetermined position has elapsed, or a sensor for detecting the package 15 may be provided at a predetermined position. Accordingly, falling off of the package 15 from the package conveyor 52 can be inhibited.

[0041] The package conveyor 52 is provided with the operation state display panel 80 described above. In the present embodiment, the operation state display panel 80 is provided at an end portion on a downstream side in the conveyance direction of the package conveyor 52. However, the operation state display panel 80 may be provided at a position other than the end portion on the downstream side of the package conveyor 52. The operation state display panel 80 provided to the package conveyor 52 displays the operation states of the package shutter 51 and the package conveyor 52.

[0042] Here, when the package conveyor 52 is simultaneously conveying two packages 15, the package conveyor 52 is stopped at a timing when a first package 15 is conveyed to a predetermined position. In this state, the package conveyor 52 waits for the operator to collect the first package 15, and the package conveyor 52 has interrupted the operation. However, since the package conveyor 52 conveys a second package 15 after the first package 15 is collected, stopping is not due to completion

of the operation of the package conveyor 52. In this state, since the package conveyor 52 is in operation, the operation state display panel 80 displays that the package conveyor 52 is in operation. Therefore, the operator can grasp at a glance whether or not the package conveyor 52 is in operation (furthermore, whether the operation is temporarily interrupted or is stopped after completion of the conveyance work of the package 15), by viewing the operation state display panel 80.

[0043] Next, the winding unit 1a will be described in detail with reference to FIG. 2. As illustrated in FIG. 2, the winding unit 1a is configured to unwind the yarn 10 of the yarn supplying bobbin 12, and wind the unwound yarn 10 around a winding tube of a winding section 22 while traversing, to form the package 15. The winding section 22 includes a cradle 31 and a winding drum 30.

[0044] The cradle 31 can rotatably support the winding tube or the package 15. Further, the cradle 31 is also able to bring a periphery of the package 15 supported by the cradle 31 into contact with a periphery of the winding drum 30.

[0045] The winding drum 30 rotates the package 15 while traversing the yarn 10 on a surface of the package 15. By driving and rotating the winding drum 30 with the periphery of the package 15 in contact with the winding drum 30, the package 15 can be driven to rotate. Further, a traverse groove with a spiral shape is formed on an outer peripheral surface of the winding drum 30, and the traverse groove allows the yarn 10 unwound from the yarn supplying bobbin 12 to be wound onto the surface of the package 15 while being traversed over a constant width. Accordingly, the package 15 having a constant winding width can be formed.

[0046] The winding unit 1a includes a bobbin setting section 20 adapted to support the yarn supplying bobbin 12, and the winding section 22 adapted to wind the yarn 10. A travelling path of the yarn 10 is formed between the bobbin setting section 20 and the winding section 22. The winding unit 1a includes an unwinding assisting device 23, a tension applying device 25, a yarn joining device 26, and a yarn quality measuring device 27 in this order from the bobbin setting section 20 side toward the winding section 22 side in an intermediate part on the travelling path.

[0047] The unwinding assisting device 23 assists in unwinding the yarn 10 from the yarn supplying bobbin 12. The unwinding assisting device 23 includes a movable member. The movable member is able to come into contact with a balloon that is formed in an upper portion of the yarn supplying bobbin 12 as a result of the yarn 10 unwound from the yarn supplying bobbin 12 being swung around. By changing a position of the movable member, the unwinding assisting device 23 can appropriately control a size of the balloon.

[0048] The tension applying device 25 applies a predetermined tension on the travelling yarn 10. The tension applying device 25 of the present embodiment has a gate type configuration in which movable comb teeth are ar-

ranged against immovable comb teeth. The movable comb teeth are configured to be rotated by a rotary solenoid so that the comb teeth have a meshed state or an unmeshed state.

[0049] The yarn quality measuring device 27 monitors, for example, a thickness of the yarn 10, to detect a yarn defect such as a slub. Further, a cutter (not illustrated), which is for cutting the yarn 10 immediately after the yarn quality measuring device 27 detects a yarn defect, is arranged near the yarn quality measuring device 27.

[0050] When the yarn 10 is broken, the yarn joining device 26 joins a lower yarn on the yarn supplying bobbin 12 side to an upper yarn on the package 15 side. On a lower side and an upper side of the yarn joining device 26, there are provided a lower yarn guide pipe 28 adapted to catch the lower yarn on the yarn supplying bobbin 12 side and guide the lower yarn to the yarn joining device 26, and an upper yarn guide pipe 29 adapted to catch the upper yarn on the package 15 side and guide the upper yarn to the yarn joining device 26. The breakage of the yarn 10 is caused, for example, when the yarn quality measuring device 27 detects a yarn defect and therefore the cutter cuts the yarn 10, when the yarn 10 unwound from the yarn supplying bobbin 12 is disconnected, or when the yarn supplying bobbin 12 is replaced. The yarn joining device 26 of the present embodiment uses compressed air to join the yarns by, for example, twisting the upper and lower yarns together.

[0051] The above-described configuration enables each winding unit 1a of the automatic winder main body 1 to unwind the yarn 10 from the yarn supplying bobbin 12 supported on the bobbin setting section 20 and wind the yarn 10 around the winding tube, to form the package 15 having a predetermined length.

[0052] Each device included in the winding unit 1a is controlled by a unit control section 95 illustrated in FIGS. 2 and 4. The unit control section 95 is provided for each winding unit 1a. The unit control section 95 can communicate with the centralized management device 91 described above.

[0053] A unit operation panel 96 is provided on a front side of the winding unit 1a. The unit operation panel 96 is used to control an operation of the devices included in the winding unit 1a. A specific structure of the unit operation panel 96 will be described later.

[0054] A spinning machine 40 illustrated in FIG. 1 winds the yarn 10 produced by drafting and twisting a roving yarn around a bobbin tube to form the yarn supplying bobbin 12. Furthermore, the spinning machine 40 forms a bunch winding in which the yarn 10 is wound around an end portion in an axial direction of the yarn supplying bobbin 12, to inhibit entanglement of the yarn 10 with a peripheral member.

[0055] As a means for supplying, to the automatic winder 100, the yarn supplying bobbin 12 around which the yarn spun by the spinning machine 40 is wound, there are the following configurations. A means for supplying the yarn supplying bobbin 12 removed from the spinning

machine 40 by the operator to the automatic winder 100 by using the supply device 3 as illustrated in FIG. 1. A means for directly supplying the yarn supplying bobbin 12 removed from the spinning machine 40 by the operator to a magazine type yarn supplying bobbin supplying mechanism included in each winding unit 1a of the automatic winder 100. Then, there is a means for connecting the spinning machine 40 and the automatic winder 100 by a conveyor, and conveying the yarn supplying bobbin 12 from the spinning machine 40 to the automatic winder 100 by the conveyor. In the present embodiment, the yarn supplying bobbin 12 is supplied to the automatic winder 100 by using the supply device 3 as illustrated in FIG. 1. The supply device 3 sets the yarn supplying bobbins 12 supplied from the spinning machine 40 one by one on a conveyance tray 16. The conveyance tray 16 supports the yarn supplying bobbin 12 in a substantially upright state. The supply device 3 is provided with the operation state display panel 80 described above. The operation state display panel 80 provided to the supply device 3 displays an operation state of the supply device 3.

[0056] As described above, the yarn supplying bobbin 12 is conveyed to the winding unit 1a via the bobbin conveyor 4 in a state where the yarn supplying bobbin 12 is placed on the conveyance tray 16, and the yarn 10 is unwound by the winding unit 1a. Then, the yarn supplying bobbin 12 after the yarn 10 is unwound is discharged from the winding unit 1a via the bobbin conveyor 4 in a state where the yarn supplying bobbin 12 is placed on the conveyance tray 16. The bobbin conveyor 4 is provided with the operation state display panel 80 described above. The operation state display panel 80 provided to the bobbin conveyor 4 displays an operation state of the bobbin conveyor 4.

[0057] The bobbin preparation system 2 is arranged between the automatic winder main body 1 and the supply device 3. The bobbin preparation system 2 includes a preparation device 8. The preparation device 8 performs pre-processing on the yarn supplying bobbin 12 to establish a state where the winding unit 1a is able to process the yarn supplying bobbin 12. The preparation device 8 unwinds the bunch winding of the yarn supplying bobbin 12 to free a yarn end. Furthermore, the preparation device 8 catches the free yarn end, pulls out the caught yarn end from the yarn supplying bobbin 12, and blows the caught yarn end toward the vicinity of a distal end portion of the yarn supplying bobbin 12. Then, by rotating the yarn supplying bobbin 12, the yarn end is wound around an upper portion of a core tube of the yarn supplying bobbin 12. In this way, the pre-processing of the yarn supplying bobbin 12 is completed. Note that some of the pre-processing described above may be omitted. The preparation device 8 is provided with the operation state display panel 80 described above. The operation state display panel 80 provided to the preparation device 8 displays an operation state of the preparation device 8.

[0058] By providing the operation state display panel 80 to the supply device 3, the bobbin conveyor 4, and the preparation device 8, the operator can grasp the operation states of these devices at a glance.

[0059] Next, the operation state display panel 80 will be mainly described with reference to FIG. 5.

[0060] As illustrated in FIG. 5, the operation state display panel 80 includes a segment display section 81 and an operation key group 82. The operation key group 82 includes an up key 82a, a down key 82b, and a center key 82c.

[0061] The segment display section 81 is a display in which segments are arranged in a plurality of rows and a plurality of columns. The segment display section 81 can individually light on or off each segment in accordance with an instruction from an outside. A method for arranging the segments of the present embodiment is a general method. The segments are arranged in a shape similar to the Arabic numeral 8, and it is possible to display one-digit Arabic numeral, some alphabets, and the like, by switching light on/off of these segments.

[0062] In the present embodiment, three seven-segment displays are arranged side by side, but one, two, or four or more seven-segment displays may be arranged side by side. Further, the segment display section 81 is not limited to the seven segments, and may have different layouts as long as segments are arranged in a plurality of rows and a plurality of columns. For example, rectangular or round dots may be arranged vertically and horizontally with a uniform width.

[0063] The operation key group 82 is used to give an instruction to a device (the doffing device 17, the package shutter 51, the package conveyor 52, the supply device 3, the bobbin conveyor 4, and the preparation device 8) whose operation state is displayed on the operation state display panel 80. The up key 82a and the down key 82b are used, for example, to select a work content, a work target, or the like. The center key 82c is used, for example, to execute the selected work content or work target. Note that the operation key group 82 illustrated in FIG. 5 is an example, and a key may be added, changed, or omitted.

[0064] For example, when an instruction is given to the package shutter 51 with use of the operation key group 82, the package shutter 51 to be operated can be selected using the up key 82a and the down key 82b. In the present embodiment, since the package shutter 51 is provided for each group of the predetermined number of winding units 1a, the target group can be selected using the up key 82a and the down key 82b. When the package shutter 51 is provided for each winding unit 1a, the target winding unit 1a can be selected using the up key 82a and the down key 82b.

[0065] Further, when an instruction is given to the bobbin conveyor 4 with use of the operation key group 82, switching of a path of the bobbin conveyor 4 can be instructed. For example, a target switching portion can be selected using the up key 82a and the down key 82b.

Note that the use examples of the operation key group 82 described above are an example, and other instructions can be given using the operation key group 82.

[0066] Further, the operation state display panel 80 provided to the doffing device 17 switches a display mode of the segment display section 81 in accordance with a command from the doffing device 17. Further, a signal based on an operation performed on the operation key group 82 is transmitted to the doffing device 17. In other words, the doffing device 17 and the operation state display panel 80 directly communicate with each other (this similarly applies to other devices). Alternatively, the operation state display panel 80 may communicate with the target device via the centralized management device 91.

[0067] Further, in the present embodiment, the operation state display panel 80 and the unit operation panel 96 have at least some parts in common. Specifically, a housing, the segment display section 81, the operation key group 82, and a board for operating these are in common. Common parts mean that the parts have the same configuration (identical specifications). By having the parts in common, a purchase cost of the product can be reduced, and an inventory management cost can be reduced. In particular, since the segment display section 81 and the board have high versatility, making the segment display section 81 and the board common makes it possible to suppress an influence on convenience and operability, while reducing the cost. Note that the operation state display panel 80 and the unit operation panel 96 may not include a common part.

[0068] Next, light on/off patterns of the segment display section 81 will be described with reference to FIGS. 6 to 8.

[0069] FIG. 6 is a view illustrating that rotation display is performed by lighting on/off each segment of the segment display section 81. As described above, the segment display section 81 includes the three seven-segment displays arranged side by side in a lateral direction. Therefore, the segment display section 81 has a horizontally long display region having a substantially rectangular shape. The segment display section 81 can perform display (rotation display) in which a lighted portion appears to rotate, by moving the lighted portion along substantially rectangular sides (outline). Specifically, first, a predetermined number (three in FIG. 6) of continuous segments among the substantially rectangular sides (outline) are lighted on, and other segments are lighted off. Thereafter, among the segments that are lighted on, a segment at an upstream end in a rotation direction is lighted off, and a segment on a downstream side in the rotation direction is lighted on. By repeating this processing at predetermined time intervals, the segment display section 81 can perform the rotational display. Further, as illustrated in FIG. 6, even when the light on/off pattern is switched, the number of segments that are lighted on is the same (the number of lighted-on segments is always three in FIG. 6). Since the number of segments that are lighted on does not change, it is possible to give a sense of unity between the individual patterns or give an im-

pression that the lighted portion is moving.

[0070] Generally, the rotation display is used to indicate that the target device is in operation. Therefore, while the device (the doffing device 17, the package shutter 51, the package conveyor 52, the supply device 3, the bobbin conveyor 4, and the preparation device 8) whose operation state is displayed on the operation state display panel 80 is in operation, the segment display section 81 may perform the rotation display. In particular, since the package conveyor 52 and the bobbin conveyor 4 convey the package 15 or the yarn supplying bobbin 12 by the rotation of the pulley, affinity with the rotation display is high. Therefore, the operator who looks at the rotation display can intuitively grasp that the package conveyor 52 or the bobbin conveyor 4 is in operation. Further, a direction of the change in the rotation display of the segment display section 81 of the operation state display panel 80 provided to the package conveyor 52 corresponds to a driving direction (rotation direction) of the package conveyor 52. A specific description will be given with reference to FIGS. 3 and 6. In FIG. 3, when the operator located in front of the operation state display panel 80 looks at the package conveyor 52, the package conveyor 52 is being rotationally driven clockwise as indicated by an arrow. As illustrated in FIG. 6, the rotation display of the segment display section 81 similarly changes clockwise. Accordingly, since the affinity between the driving of the package conveyor 52 and the display of the segment display section 81 is high, the operator can more intuitively grasp the operation of the package conveyor 52.

[0071] In the present embodiment, the rotation display is performed using the three seven-segment displays, but the rotation display can be performed in a similar procedure even when one, two, or four or more seven-segment displays are used.

[0072] FIG. 7 is a view illustrating that vertical movement display is performed by lighting on/off each segment of the segment display section 81. The seven-segment display includes three horizontal bar-shaped segments arranged vertically. Therefore, by switching light on/off of the horizontal bar-shaped segments, it is possible to perform display (vertical movement display) in which a lighted portion appears to move up and down. Specifically, first, a horizontal bar-shaped segment located at the uppermost (or lowermost) is lighted on. Thereafter, while the horizontal bar-shaped segment located at the uppermost (or lowermost) is lighted off, a horizontal bar-shaped segment located at a center is lighted on. Thereafter, while the horizontal bar-shaped segment located at the center is lighted off, a horizontal bar-shaped segment located at the lowermost (or uppermost) is lighted on. By repeating the above processing, the segment display section 81 can perform the vertical movement display. Further, as illustrated in FIG. 7, even when the light on/off pattern is switched, the number of segments that are lighted on is the same (the number of lighted-on segments is always three in FIG. 7).

[0073] Furthermore, in the present embodiment, the segment display section 81 includes the three seven-segment displays arranged side by side in the lateral direction. Therefore, by lighting on/off the horizontal bar-shaped segments of each of the three seven-segment displays at the same timing, the segment display section 81 can perform the vertical movement display using the three seven-segment displays.

[0074] The vertical movement display is used for movement of some object from the top to the bottom or from the bottom to the top. Therefore, for example, affinity with the operation of the package shutter 51 (switching between the first state and the second state) is high. Further, the operation state display panel 80 illustrated in FIG. 3 displays operation states of both the package shutter 51 and the package conveyor 52. Therefore, the operation state display panel 80 is required to distinguish and display whether the package shutter 51 is in operation or the package conveyor 52 is in operation. Therefore, the operation state display panel 80 performs the vertical movement display when the package shutter 51 is in operation, and performs the rotation display when the package conveyor 52 is in operation. By selectively using the plurality of types of display in this manner, the operation states of the plurality of devices can be displayed on one operation state display panel 80.

[0075] Specifically, when the operator instructs collection of the package 15, the segment display section 81 first performs the vertical movement display. Thereafter, the segment display section 81 performs the rotation display at a timing when the package 15 reaches the package conveyor 52. Accordingly, the operator can know a situation of the collection of the package 15 by simply viewing the operation state display panel 80. Note that switching from the vertical movement display to the rotation display can be performed according to time, for example. That is, the vertical movement display is started and counting is started after an instruction of the operator or after the operation of the package shutter 51, and the vertical movement display is switched to the rotation display at a timing when the count reaches a predetermined value. Note that switching from the vertical movement display to the rotation display is not limited to time. For example, the vertical movement display may be switched to the rotation display with, as a trigger, detection of the package 15 by a sensor or the like provided to the package conveyor 52 side.

[0076] Note that the vertical movement display may be used to indicate an operation status of other devices, without limiting to the operation status of the package shutter 51. Furthermore, in the present embodiment, the rotation display is performed using the three seven-segment displays, but the rotation display can be performed in a similar procedure even when one, two, or four or more seven-segment displays are used.

[0077] FIG. 8 is a view illustrating that on/off display is performed by lighting on/off each segment of the segment display section 81. The seven-segment display can

display some alphabets in addition to numbers. In addition, the segment display section 81 of the present embodiment includes the three seven-segment displays arranged side by side in the lateral direction. Therefore, three alphabets can be displayed. As described above, as illustrated in FIG. 8, the segment display section 81 can display "on" and "off".

[0078] When the on/off display is used, the segment display section 81 performs the "on" display when the target device (the doffing device 17, the package shutter 51, the package conveyor 52, the supply device 3, the bobbin conveyor 4, and the preparation device 8) is in operation. When the target device is not in operation, the segment display section 81 performs the "off" display. The on/off display has high affinity with all devices.

[0079] The regular light-on and light-off patterns illustrated in FIGS. 6 to 8 described above are an example, and other patterns may be used to indicate the operation status of each device. For example, the segment display section 81 may display whether or not being in operation by lighting on or blinking a predetermined number or character.

[0080] As described above, the automatic winder 100 of the present embodiment includes the plurality of winding units 1a, the doffing device 17, the package conveyor 52, and the operation state display panel 80. The winding unit 1a unwinds the yarn from the yarn supplying bobbin 12, and winds the unwound yarn to individually form the package 15. The doffing device 17 doffs the package 15 formed by the winding unit 1a by removing the package 15. The package conveyor 52 conveys the package 15 doffed by the doffing device 17. The operation state display panel 80 is provided to the doffing device 17 and the package conveyor 52. The operation state display panel 80 includes the segment display section 81 including a plurality of columns and a plurality of rows of segments. The segment display section 81 of the operation state display panel 80 displays an operation state of at least one of the doffing device 17 or the package conveyor 52, with a regular light-on and light-off pattern.

[0081] Accordingly, the operation state is displayed for at least one of the doffing device 17 or the package conveyor 52, so that the operator can easily check, for example, whether the target device has temporarily interrupted the operation during work or has stopped after completion of the work.

[0082] In the automatic winder 100 of the present embodiment, the segment display section 81 of the operation state display panel 80 is a seven-segment display.

[0083] Accordingly, various types of display can be performed while the number of segments is suppressed.

[0084] In the automatic winder 100 of the present embodiment, the winding unit 1a includes the unit operation panel 96 for control of the operation of the device of the winding unit 1a. The unit operation panel 96 includes the segment display section 81 including a plurality of columns and a plurality of rows of segments. The segment display section 81 of the operation state display panel 80

and the segment display section 81 of the unit operation panel 96 have the same configuration.

[0085] Accordingly, at least some of components can be made common between the unit operation panel 96 and the operation state display panel 80, so that a cost can be reduced.

[0086] The automatic winder 100 of the present embodiment includes the preparation device 8 and the bobbin conveyor 4. The preparation device 8 performs pre-processing on the yarn supplying bobbin 12 to establish a state where the winding unit 1a is able to process the yarn supplying bobbin 12. The bobbin conveyor 4 supplies the yarn supplying bobbin 12 pre-processed by the preparation device 8 to the winding unit 1a. The operation state display panel 80 is further provided to at least one of the preparation device 8 or the bobbin conveyor 4, and the segment display section 81 of the operation state display panel 80 further displays an operation state of at least one of the preparation device 8 or the bobbin conveyor 4.

[0087] Accordingly, the operation state is displayed for at least one of the preparation device 8 or the bobbin conveyor 4, so that the operator can easily check, for example, whether the operation is temporarily interrupted during work or is stopped after completion of the work.

[0088] The automatic winder 100 of the present embodiment includes the supply device 3 adapted to supply the yarn supplying bobbin 12 to the bobbin conveyor 4. The operation state display panel 80 is further provided to the supply device 3, and the segment display section 81 of the operation state display panel 80 further displays an operation state of the supply device 3.

[0089] Accordingly, the operation state of the supply device 3 is displayed on the operation state display panel 80, so that the operator can easily check, for example, whether the supply device 3 has temporarily interrupted the operation during work or has stopped after completion of the work.

[0090] In the automatic winder 100 of the present embodiment, the operation state display panel 80 is provided to the package conveyor 52. The segment display section 81 of the operation state display panel 80 provided to the package conveyor 52 displays an operation state of the package conveyor 52.

[0091] Accordingly, the operation state of the package conveyor 52 is displayed, so that the operator can easily check, for example, whether the operation is temporarily interrupted during work or is stopped after completion of the work.

[0092] In the automatic winder 100 of the present embodiment, when the package conveyor 52 is in operation, the segment display section 81 of the operation state display panel 80 provided to the package conveyor 52 performs display in which a lighted portion appears to rotate, by making a difference in timing of lighting on and off for each segment.

[0093] Accordingly, a concept is similar between the package conveyor 52 is operating and the lighted portion

is rotating, so that the operator can intuitively grasp that the package conveyor 52 is operating.

[0094] The automatic winder 100 of the present embodiment includes the package shutter 51 capable of switching between: a first state in which the package 15 is able to move from the winding unit 1a to the package conveyor 52; and a second state in which the package 15 is unable to move from the winding unit 1a to the package conveyor 52. A single operation state display panel 80 displays an operation state of the package conveyor 52 and an operation state of the package shutter 51.

[0095] Accordingly, since the operation states of the two devices operating in series are displayed on one operation state display panel 80, the operator can grasp the operation states of the two devices operating in series by simply viewing one operation state display panel 80.

[0096] The automatic winder 100 of the present embodiment includes the package shutter 51 capable of switching between: a first state in which the package 15 is able to move from the winding unit 1a to the package conveyor 52; and a second state in which the package 15 is unable to move from the winding unit 1a to the package conveyor 52. The segment display section 81 of the operation state display panel 80 that displays the operation state of the package shutter 51 performs display in which a lighted portion appears to vertically move, by making a difference in timing of lighting on and off for each segment.

[0097] Accordingly, since a concept is similar between that the package shutter 51 is operating and that the lighted portion is vertically moving, the operator can intuitively grasp that the package shutter 51 is operating.

[0098] In the automatic winder 100 of the present embodiment, the segment display section 81 indicates that the target device is operating, by displaying characters "on" by lighting on or off the segments. The segment display section 81 indicates that the target device is stopped, by displaying characters "off" by lighting on or off the segments.

[0099] In the automatic winder 100 of the present embodiment, when the seven-segment display of the operation state display panel 80 is lighted on in a regular light-on and light-off pattern, the number of segments that are lighted on is the same in the individual patterns.

[0100] Accordingly, a sense of unity can be provided between the individual patterns.

[0101] Accordingly, the operator can grasp whether or not the device is in operation at a glance.

[0102] The preferred embodiment of the present invention has been described above, but the above-described configuration may be modified as below.

[0103] The operation state display panel 80 of the above-described embodiment includes the segment display section 81 and the operation key group 82, but the operation key group 82 may be omitted. In addition, members other than the segment display section 81 and the operation key group 82 may be provided to the operation state display panel 80.

[0104] The operation state display panel 80 is only required to be provided to at least one of the doffing device 17 or the package conveyor 52, and other operation state display panels 80 may be omitted. Further, in the present embodiment, the operation state display panel 80 provided to the package conveyor 52 displays the operation states of both the package shutter 51 and the package conveyor 52, but may display only one of the operation states.

[0105] In the above-described embodiment, the rotation display, the vertical movement display, and the on/off display have been described as examples of display performed by the operation state display panel 80, but other types of display may be performed. For example, the segment display section 81 of the operation state display panel 80 may perform left-right movement display in which a lighted portion moves in a left direction or a right direction.

Claims

1. An automatic winder (100) comprising:

a plurality of winding units (1a) each adapted to unwind a yarn from a yarn supplying bobbin (12) and wind the unwound yarn to form a package (15);

a doffing device (17) adapted to doff the package (15) formed by each of the winding units (1a);
a package conveyor (52) adapted to convey the package (15) doffed by the doffing device (17);
and

an operation state display panel (80), wherein the operation state display panel (80) is provided to the doffing device (17) and the package conveyor (52),

the operation state display panel (80) includes a segment display section (81) including a plurality of columns and a plurality of rows of segments, and
the segment display section (81) of the operation state display panel (80) displays an operation state of at least one of the doffing device (17) or the package conveyor (52), with a regular light-on and light-off pattern.

2. The automatic winder (100) as claimed in claim 1, wherein the segment display section (81) of the operation state display panel (80) is one or more seven-segment displays.

3. The automatic winder (100) as claimed in claim 1 or 2, wherein

each of the winding units (1a) includes a unit operation panel (96) for control of an operation of a device included in each of the winding units

(1a),

the unit operation panel (96) includes a segment display section (81) including a plurality of columns and a plurality of rows of segments, and the segment display section (81) of the operation state display panel (80) and the segment display section (81) of the unit operation panel (96) have a same configuration.

4. The automatic winder (100) as claimed in any one of claims 1 to 3, comprising:

a preparation device (8) adapted to perform pre-processing on the yarn supplying bobbin (12);
and

a bobbin conveyor (4) adapted to supply the yarn supplying bobbin (12) pre-processed by the preparation device (8) to each of the winding units (1a), wherein

the operation state display panel (80) is further provided to at least one of the preparation device (8) or the bobbin conveyor (4), and the segment display section (81) of the operation state display panel (80) displays an operation state of at least one of the preparation device (8) or the bobbin conveyor (4).

5. The automatic winder (100) as claimed in claim 4, comprising a supply device (3) adapted to supply the yarn supplying bobbin (12) to the bobbin conveyor (4), wherein
the operation state display panel (80) is further provided to the supply device (3), and the segment display section (81) of the operation state display panel (80) displays an operation state of the supply device (3).

6. The automatic winder (100) as claimed in any one of claims 1 to 5, wherein

the operation state display panel (80) is further provided to the package conveyor (52), and the segment display section (81) of the operation state display panel (80) provided to the package conveyor (52) displays an operation state of the package conveyor (52).

7. The automatic winder (100) as claimed in claim 6, wherein

when the package conveyor (52) is in operation, the segment display section (81) of the operation state display panel (80) provided to the package conveyor (52) performs display in which a lighted portion appears to rotate, by making a difference in timing of lighting on and off for each of the segments.

8. The automatic winder (100) as claimed in claim 6 or 7, comprising a package shutter (51) capable of

switching between:

a first state in which the package (15) is able to move from each of the winding units (1a) to the package conveyor (52); and a second state in which the package (15) is unable to reach the package conveyor (52) from each of the winding units (1a) to, wherein
 a single piece of the operation state display panel (80) displays the operation state of the package conveyor (52) and an operation state of the package shutter (51).

5

10

9. The automatic winder (100) as claimed in any one of claims 1 to 7, comprising a package shutter (51) capable of switching between: a first state in which the package (15) is able to move from each of the winding units (1a) to the package conveyor (52); and a second state in which the package (15) is unable to reach the package conveyor (52) from each of the winding units (1a), wherein
 the segment display section (81) of the operation state display panel (80) that displays an operation state of the package shutter (51) performs display in which a lighted portion appears to vertically move, by making a difference in timing of lighting on and off for each of the segments.

15

20

25

10. The automatic winder (100) as claimed in claim 2, wherein when the seven-segment display of the operation state display panel (80) is lighted on in a regular light-on and light-off pattern, a same number of segments is lighted on in the individual patterns.

30

11. The automatic winder (100) as claimed in any one of claims 1 to 9, wherein

35

the segment display section (81) displays characters "on" by lighting on or off the segments, to indicate that a target device is operating, and the segment display section (81) displays characters "off" by lighting on or off the segments, to indicate that the target device is stopped.

40

45

50

55

FIG. 1

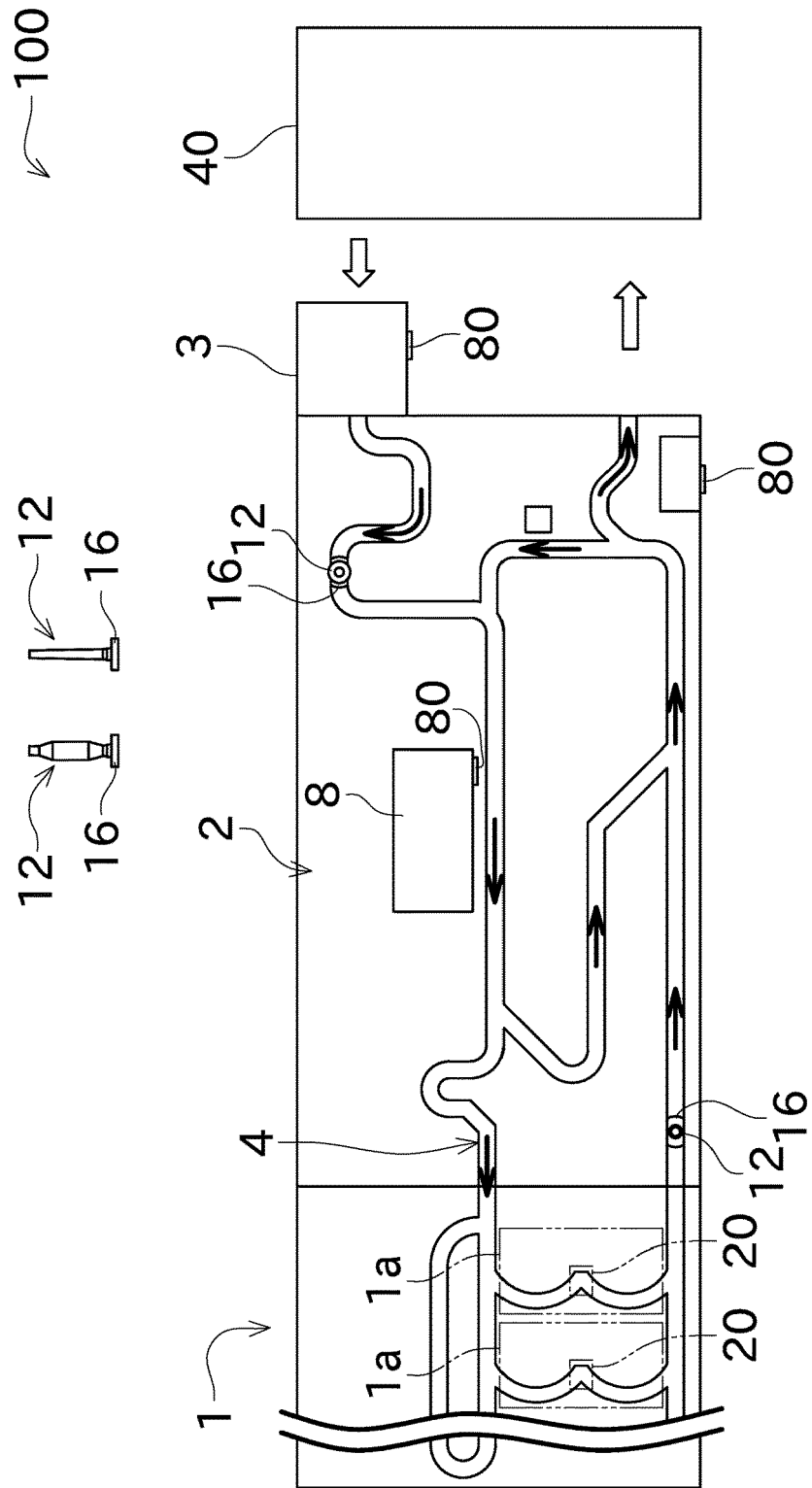

FIG. 3

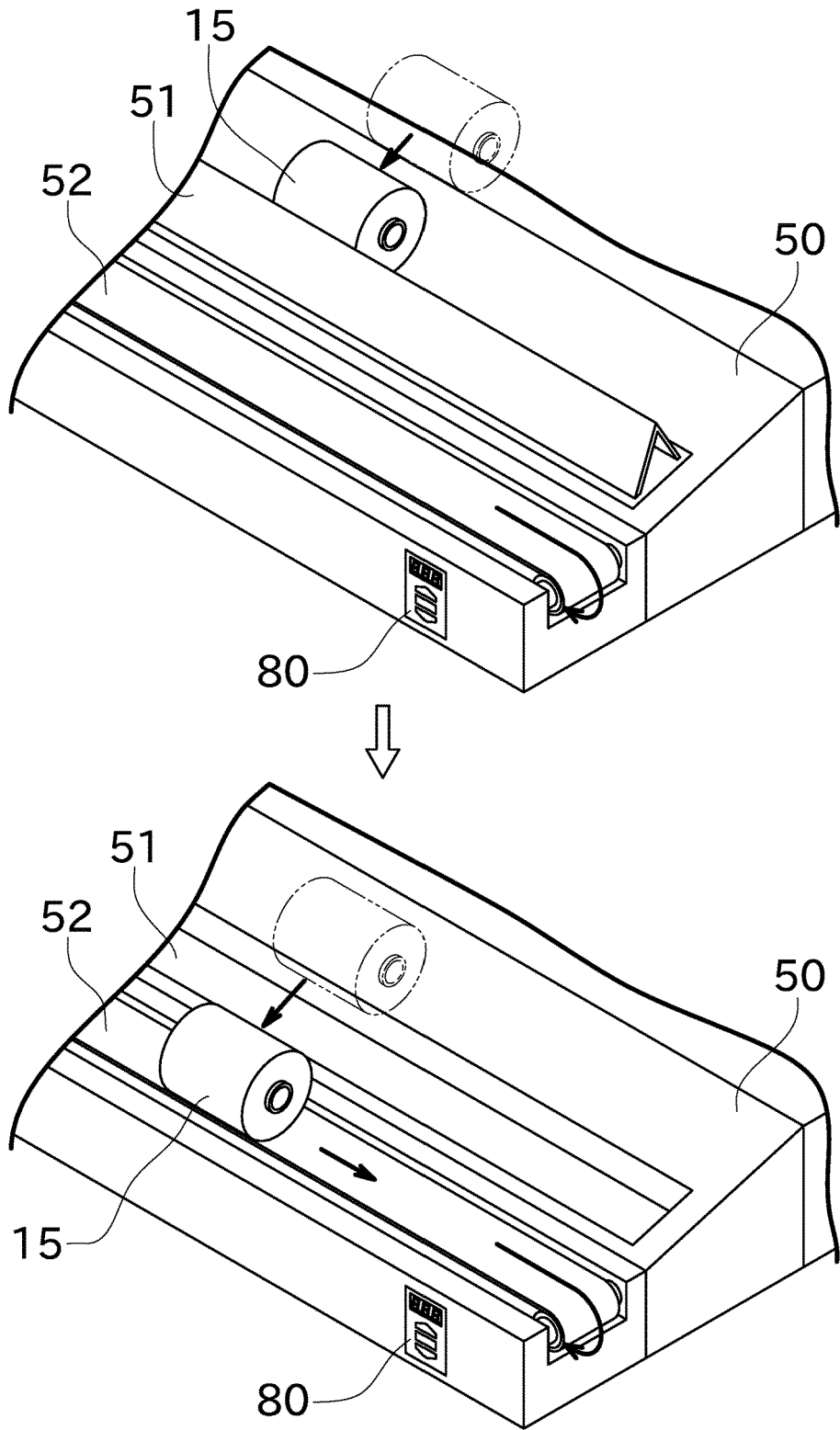

FIG. 4

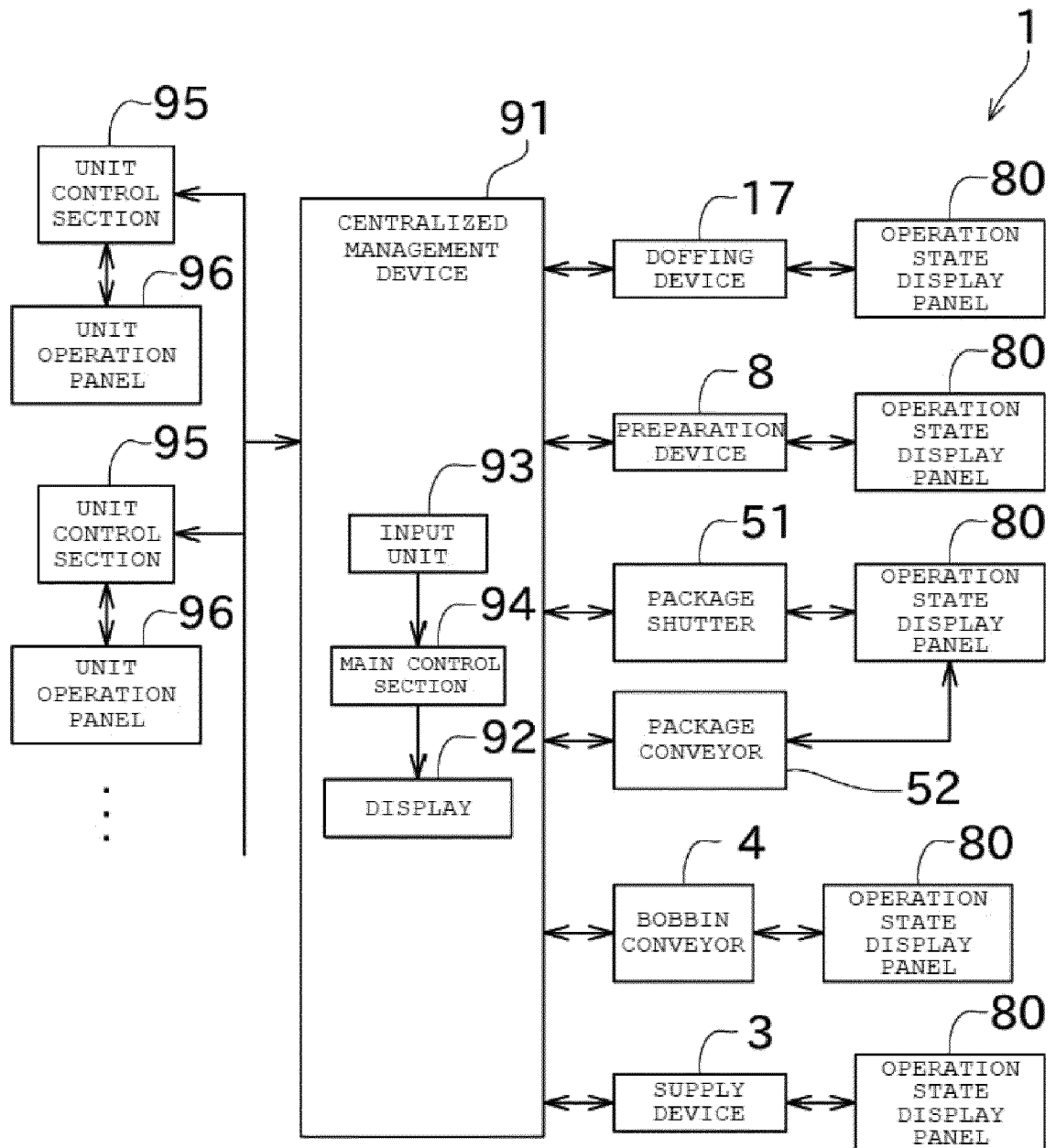

FIG. 5

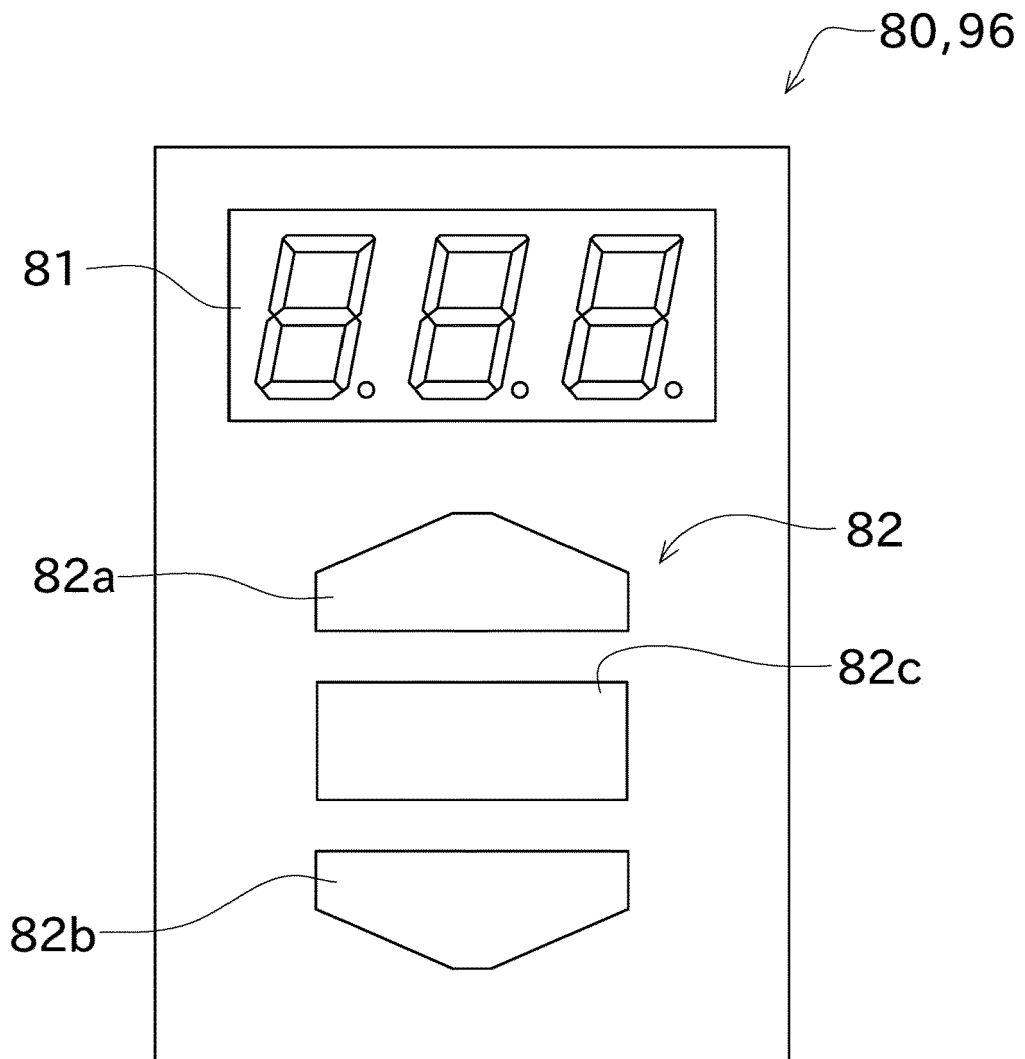

FIG. 6

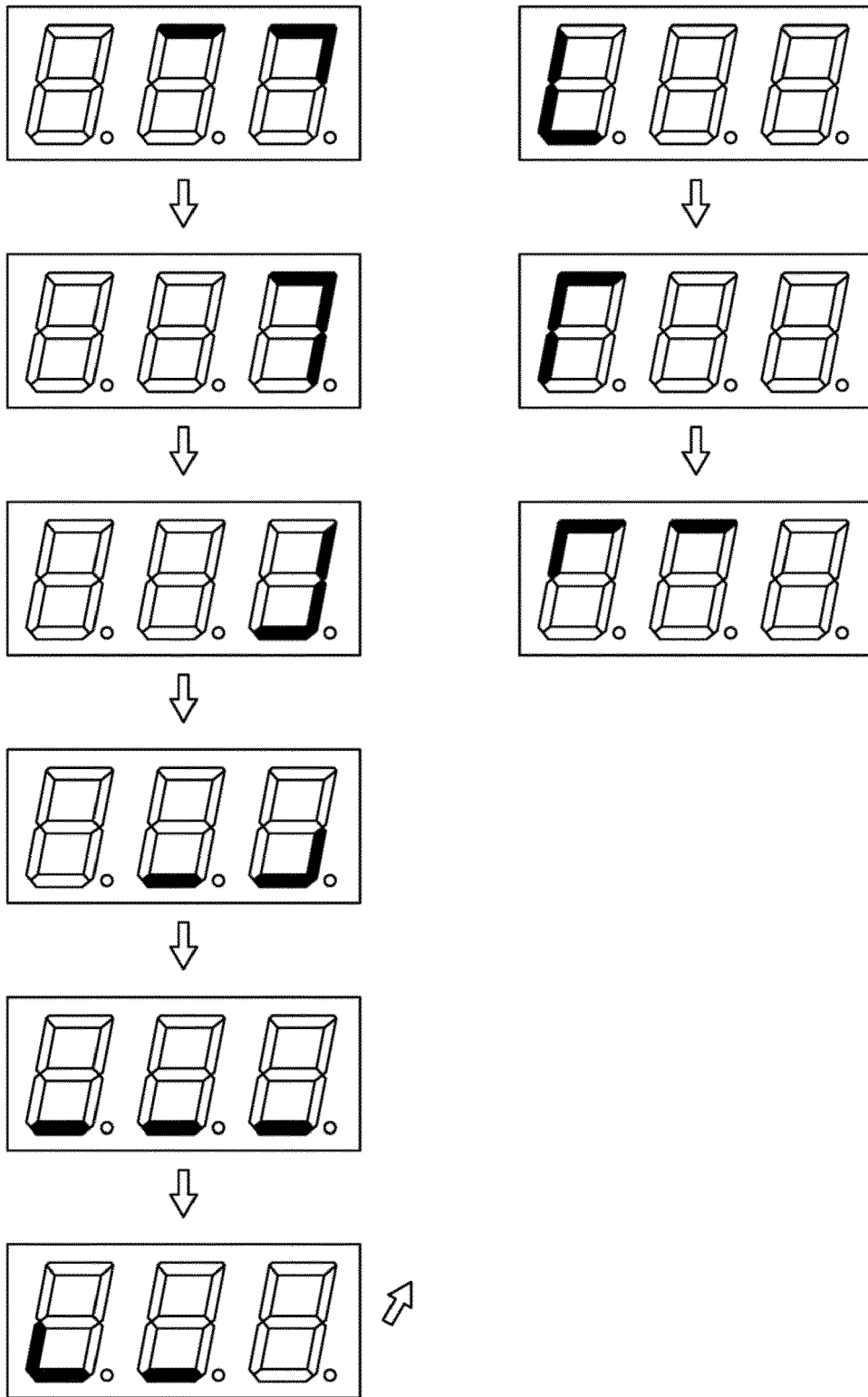

FIG. 7

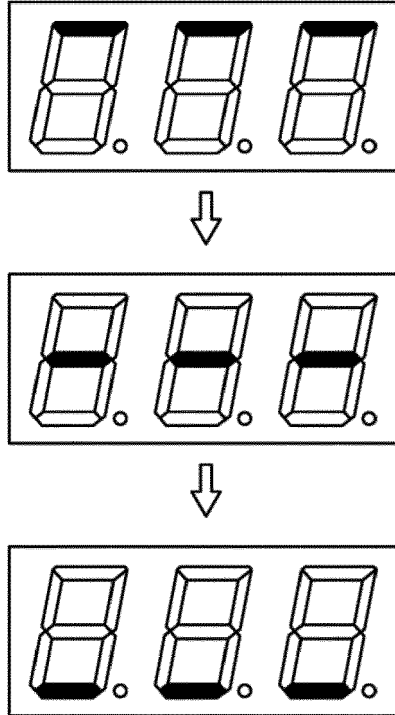
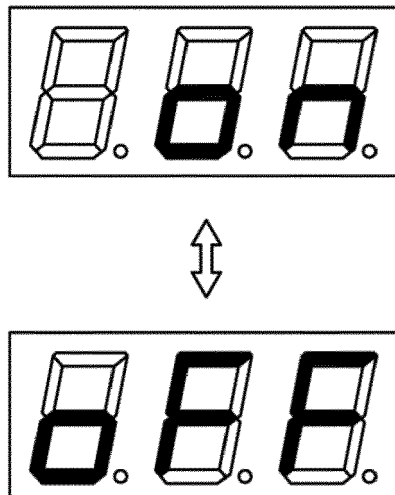

FIG. 8





EUROPEAN SEARCH REPORT

Application Number
EP 23 19 0252

5

10

15

20

25

30

35

40

45

50

55

DOCUMENTS CONSIDERED TO BE RELEVANT			
Category	Citation of document with indication, where appropriate, of relevant passages	Relevant to claim	CLASSIFICATION OF THE APPLICATION (IPC)
X	<p>EP 3 744 670 A1 (MURATA MACHINERY LTD [JP]) 2 December 2020 (2020-12-02)</p> <p>* paragraph [0035] - paragraph [0037] *</p> <p>* paragraph [0044] - paragraph [0047] *</p> <p>* paragraph [0064] - paragraph [0067] *</p> <p>* paragraph [0075] *</p> <p>* figures 1-4, 9, 13(a)-13(c) *</p> <p>-----</p>	1-11	<p>INV.</p> <p>B65H54/26</p> <p>B65H63/00</p> <p>B65H67/04</p>
A	<p>EP 2 671 983 A2 (MURATA MACHINERY LTD [JP]) 11 December 2013 (2013-12-11)</p> <p>* paragraph [0027] - paragraph [0028] *</p> <p>-----</p>	1	<p>TECHNICAL FIELDS SEARCHED (IPC)</p> <p>B65H</p>
A	<p>EP 1 902 991 B1 (MURATA MACHINERY LTD [JP]) 7 July 2010 (2010-07-07)</p> <p>* paragraph [0025] *</p> <p>* paragraph [0031] - paragraph [0035] *</p> <p>* paragraph [0037] - paragraph [0041] *</p> <p>* figures 1, 2, 4 *</p> <p>-----</p>	1	
<p>The present search report has been drawn up for all claims</p>			
Place of search		Date of completion of the search	Examiner
The Hague		19 December 2023	Guisan, Thierry
<p>CATEGORY OF CITED DOCUMENTS</p> <p>X : particularly relevant if taken alone</p> <p>Y : particularly relevant if combined with another document of the same category</p> <p>A : technological background</p> <p>O : non-written disclosure</p> <p>P : intermediate document</p> <p>T : theory or principle underlying the invention</p> <p>E : earlier patent document, but published on, or after the filing date</p> <p>D : document cited in the application</p> <p>L : document cited for other reasons</p> <p>& : member of the same patent family, corresponding document</p>			

2
EPO FORM 1503 03:82 (P04C01)

**ANNEX TO THE EUROPEAN SEARCH REPORT
ON EUROPEAN PATENT APPLICATION NO.**

EP 23 19 0252

5 This annex lists the patent family members relating to the patent documents cited in the above-mentioned European search report.
The members are as contained in the European Patent Office EDP file on
The European Patent Office is in no way liable for these particulars which are merely given for the purpose of information.

19-12-2023

Patent document cited in search report	Publication date	Patent family member(s)	Publication date
EP 3744670 A1	02-12-2020	CN 111629984 A	04-09-2020
		EP 3744670 A1	02-12-2020
		JP 2019127361 A	01-08-2019
		WO 2019146306 A1	01-08-2019

EP 2671983 A2	11-12-2013	CN 103449257 A	18-12-2013
		CN 106927307 A	07-07-2017
		EP 2671983 A2	11-12-2013
		EP 2957664 A1	23-12-2015
		JP 2013249189 A	12-12-2013

EP 1902991 B1	07-07-2010	EP 1902991 A1	26-03-2008
		JP 2008074523 A	03-04-2008

EPO FORM P0459

For more details about this annex : see Official Journal of the European Patent Office, No. 12/82

REFERENCES CITED IN THE DESCRIPTION

This list of references cited by the applicant is for the reader's convenience only. It does not form part of the European patent document. Even though great care has been taken in compiling the references, errors or omissions cannot be excluded and the EPO disclaims all liability in this regard.

Patent documents cited in the description

- JP 2010269915 A [0002]