



(11) **EP 4 321 704 A1**

(12) **EUROPEAN PATENT APPLICATION**

(43) Date of publication:
14.02.2024 Bulletin 2024/07

(51) International Patent Classification (IPC):
E04F 13/08^(2006.01)

(21) Application number: **23188028.7**

(52) Cooperative Patent Classification (CPC):
E04F 13/0832; E04F 13/0883

(22) Date of filing: **27.07.2023**

(84) Designated Contracting States:
**AL AT BE BG CH CY CZ DE DK EE ES FI FR GB
GR HR HU IE IS IT LI LT LU LV MC ME MK MT NL
NO PL PT RO RS SE SI SK SM TR**
Designated Extension States:
BA
Designated Validation States:
KH MA MD TN

(71) Applicant: **HARINCK NV**
8710 Wielsbeke (BE)

(72) Inventor: **DE MUNSTER, Franck**
8710 Wielsbeke (BE)

(74) Representative: **Bureau M.F.J. Bockstael NV**
Arenbergstraat 13
2000 Antwerpen (BE)

(30) Priority: **10.08.2022 BE 202205624**

(54) **WALL CLADDING WITH PANELS**

(57) Wall cladding comprising several frames (2) and several panels (7), whereby each frame is composed of profiles and whereby against the front side of each frame at least one of the panels (7) is applied. The wall cladding further comprises connecting elements (6), applied for connecting adjacent frames (2) in grooves (9) formed all around in the outer edge of the frames. Each panel (7) is attached to the corresponding frame (2) by means of

at least one or more first coupling parts (8) that are attached to the panel and by one or more cooperating second coupling parts (4) that are attached to the profiles, whereby the first coupling parts and the second coupling parts are provided to attract or reject each other magnetically, in such a way that they allow a mutual shift of the panel relative to the frame, in a direction parallel to the plane of the panel.

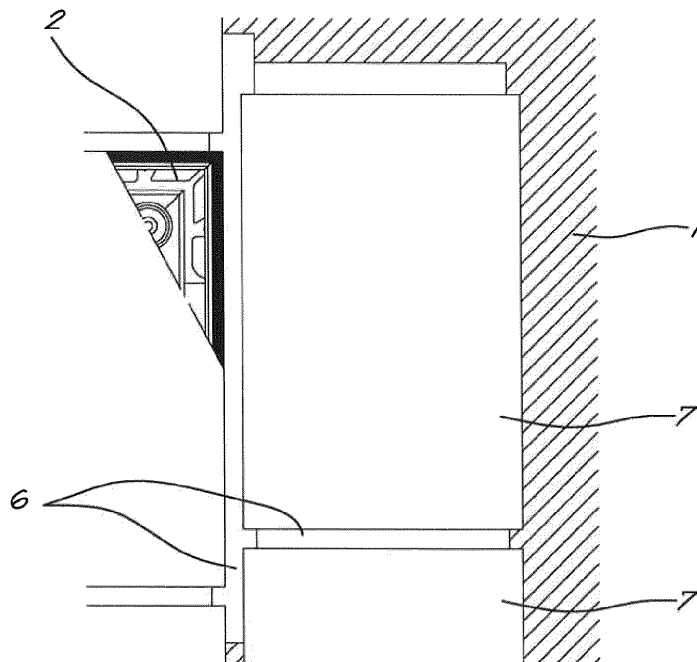

Fig. 3

EP 4 321 704 A1

Description

[0001] The present invention relates to cladding visible construction components such as walls, more particularly, the invention is intended for invisibly attaching several sheets as cladding of walls.

[0002] Cladding walls by attaching sheet material to walls is known. The sheet material can be applied directly to the wall. However, usually it is opted to first apply profiles to the wall and subsequently to attach the sheet material to the profiles. This allows any surface irregularities on the wall to be eliminated and/or to obtain a better insulation between wall and cladding, if relevant by applying extra insulating material between wall and cladding.

[0003] Attaching the sheets using nails or screws is known. However, a disadvantage of this is that said fasteners remain visible. Panels are already known which are provided with a tongue and groove and can be attached invisibly to the profiles using snap-in fasteners and nails or screws. However, a disadvantage of this is that the sheet material needs extra machining to be provided with such tongue and groove. Furthermore, such tongue and groove connection is only able to accommodate any thermal expansion/contraction of the panels as a result of changes in the environmental conditions to a limited extent.

[0004] Gluing the sheets to the profiles is also known. A disadvantage of gluing is that in case of significant temperature differences between the profiles and the sheet material, for example when the sheets are exposed to the full sun, the sheets warp. A further disadvantage is that gluing is a labour-intensive process step which needs to be carried out under strictly controlled circumstances. Furthermore, once applied, it is very difficult to still shift the panel in the plane of the panel to obtain a good mutual alignment of the panels. Once the glue is dried, the panel can no longer be removed either without causing damage.

[0005] The purpose of the present invention is to provide a solution to at least one of the aforementioned and other disadvantages.

[0006] To this end, the invention relates to wall cladding comprising several frames and several panels, whereby each frame is composed of profiles with a front wall and rear wall, respectively at the front side and at the rear side of the frame, an inner wall and an outer wall, respectively on the inner edge and on the outer edge of the frame, and whereby against the front side of every frame at least one of the panels is applied, hereby at least partially covering the front side of the frame.

[0007] Examples of walls comprise exterior facades, interior walls or other partition elements, ceilings, dormers, awnings, and gates.

[0008] The wall cladding further comprises at least one connecting element that can be slid in. The profiles are provided with a groove in their outer walls, being the walls that are part of the outer edge of the frame. Each groove extends lengthways over the entire outer wall of the pro-

file and consequently has open ends. The frame is composed of profiles provided with grooves in such a way that the frame is provided with a continuous groove all around the outer edge. This allows adjacent frames to be connected by sliding a connecting element or connecting elements in the opposite grooves of the overlapping outer edges of the adjacent frames.

[0009] Said configuration allows a simple and reliable mounting of the wall cladding. After a first frame is attached to the wall, a next frame can be attached adjacently without the respective frames touching each other. In the opposite grooves in the outer edge of the respective frames in the adjacent section, at least one connecting element can subsequently be slid in via an open freely accessible end of the relevant grooves such that the frames are connected to each other. Sliding in the connecting elements can be postponed to a later time during wall mounting provided that the relevant opposite grooves still have a freely accessible open end at that later time. Subsequently, further frames and connecting elements can systematically be applied until the entire wall to be cladded is provided with the necessary frames connected by connecting elements.

[0010] An advantage is that the connecting elements between the frames are applied without visible fasteners. Moreover, applying the connecting elements in the grooves of neighbouring frames, attached to one and the same wall, ensures that the corresponding panels substantially lie in one plane when attached.

[0011] Each panel of the wall cladding is attached to the corresponding frame by means of at least one or more first coupling parts that are attached to the panel and by one or more cooperating second coupling parts that are attached to the profiles, whereby the first coupling parts and the second coupling parts are provided to attract or reject each other magnetically, in such a way that they allow a mutual shift of the coupling parts, and thus of the panel relative to the frame, in a direction parallel to the plane of the panel. The magnetic coupling also allows the panels to be replaced easily without disturbing the mounted frames and connecting elements.

[0012] An advantage is that the panels are applied without visible attachments. Because the attachment of the panels to the frames is only magnetic, no other means are necessary to fix the panel against the frame apart from the magnetic cooperating coupling parts.

[0013] Preferably, of each pair of first and second coupling parts there is at least one coupling part in the form of a permanent magnet, whereas the other coupling part is made from a material that is attracted or rejected by a magnet, for example in the form of a second magnet or an object made from magnetic material such as a steel plate, for example. In a practical embodiment the first coupling parts are steel strips.

[0014] Magnets exert a great attraction force in a direction perpendicular to their contact surface, but offer only a small resistance to a lateral shift in the direction of the contact surface. This offers the additional advan-

tage that after attachment of a panel to a frame, the panel can still be shifted if necessary for a correct alignment relative to the frame. For the same reason, the magnetic coupling will offer little resistance to a lateral expansion or contraction of the panel by heating or cooling respectively. Consequently, and because there are no other fasteners either, heating or cooling of the panels will not cause the frame or the profiles of the frame to deform or warp due to expansion or contraction of the panel.

[0015] Moreover, attaching a panel to a frame is done simply and quickly by placing the panel with the side on which the first coupling parts are attached against the front side of the frame to couple the panel magnetically to the frame via the first and second coupling parts.

[0016] In a practical embodiment a rubber strip is applied between each frame and corresponding panel or panels. Said rubber strip simplifies placing a panel on, and aligning it with, the corresponding frame. The rubber strip between frame and panel can be applied around the entire frame. This has the advantage that it creates a seal that prevents or makes it difficult for water or moist air to seep or penetrate between the frame and panel into the space formed by the rear side of the panel and the original wall. The rubber strip can be applied in such a way that it substantially extends up to the outer edge of the frame.

[0017] In one embodiment the panels and frames are aligned such that each panel completely covers the front side of the corresponding frame.

[0018] In a further embodiment, the connecting elements are oblong and wide so much so that when applied between two adjacent frames, said frames do not touch the respective panel or the respective panels attached thereto. Said configuration ensures that on the one hand the space between the frames is filled and therefore the original wall is no longer visible, and on the other hand that space is created such that frames and panels can expand in the event of heating.

[0019] Preferably, the connecting elements and panels are configured such that after placing there is no contact between connecting elements and panels.

[0020] The form of the connecting elements and the form of the grooves are mutually aligned with each other such that the connecting elements can be fittingly and easily applied. The connecting elements can be placed by sliding them into the respective grooves. A groove has a bottom which delimits said groove depth-wise, and two opposite sidewalls which delimit the groove on the upperside and underside respectively. Preferably, the section of the connecting element that is located opposite the sidewalls of the groove, when the connecting element is applied in the groove, has a flat surface. The connecting elements are for example, made flat, T-shaped, or L-shaped. The L-shape means it is possible to not only clad flat walls but also outer corners and inner corners.

[0021] Optionally, at least a section of the surface of the profile of the frame that is exposed in the groove, which is formed in the profile of the frame for inserting a

connecting element, can be provided with a surface profile that consists of alternating grooves and dams. For example, this is possible in one or both sidewalls of the groove. Said surface profile increases the tolerance upon mounting as sliding in is simplified because the connecting element does not get stuck as easily upon sliding in. The surface profile also makes it difficult for water or moist air to seep or penetrate behind the wall via the possible space between the connecting element and the profile in the groove.

[0022] To further limit the negative effects of lateral expansion upon cooling or heating of the panels, in one embodiment according to the invention the panels, the profiles of the frames, and the connecting elements are made from one and the same material, preferably aluminium.

[0023] With the intention of better showing the characteristics of the invention, a preferred embodiment of a wall cladding according to the invention is described hereinafter, by way of an example without any limiting nature, with reference to the accompanying drawings wherein:

figure 1 schematically shows a front view and cross-section according to line AA' of a section of a wall cladding without panels according to the invention; figure 2 shows a rear view of a panel of the wall cladding according to an embodiment of the invention;

figure 3 shows the front view as shown in figure 1 whereby the panels as shown in figure 2, are applied on the frames;

figure 4 schematically shows a cross-section of a profile of a frame of the wall cladding according to the present invention on a larger scale;

figure 5 schematically shows a cross-section of the wall cladding attached to a wall with an inner corner and an outer corner according to an embodiment of the present invention.

[0024] Figure 1 schematically shows a section of a flat wall 1 to which several frames 2 are attached. Each frame 2 is constructed from several profiles that can be slid into each other or are attached to each other in another known way. The profiles have a front wall and rear wall, respectively on the front side and on the rear side of the frame, an inner wall and an outer wall, respectively on the inner edge and on the outer edge of the frame. The attachment of the frames with the rear side against the original wall is done using screws 3 or screws and plugs. The space between the inner edges of a frame may be filled with a sound and/or heat insulating material. Preferably, the profiles of the frame are made from aluminium but other materials can also be used of course.

[0025] Second coupling parts 4, more specifically permanent magnets, are attached to the profiles on the front side of each frame. The permanent magnets are mechanically attached to the profiles with rivets. A rubber

strip 5 which extends up to the outer edge of the frame is applied around each frame on the front side of the frame. A groove is provided in the outer wall of the profiles on the outer edge of each frame in which a connecting element 6, in the form of an aluminium flat slat, is slid

which ensures a connection between adjacent frames and visibly shields the original wall between the frames. **[0026]** Figure 2 shows the rear side of a panel 7 on which first coupling parts 8 in the form of two steel strips are applied. The steel strips are attached to the panel using an adhesive film. The panel is made from aluminium but alternatively can also be a panel made from another metal such as for example copper, brass or bronze but also from a random other material that can be made in panel form such as, for example, (mirrored) glass, ceramics, natural stone, wood or synthetic material.

[0027] The panels 7 can simply be placed on the respective frame 2 with the side provided with the steel strips 8 whereby the steel strips 8 and the permanent magnets 4 mutually attract each other. The permanent magnets 4 and the steel strips 8 are configured and mounted such that their contact surface is substantially parallel to the plane of the panels. A characteristic of the magnetic coupling parts 4 and 8 is that they attract each other strongly in the direction perpendicular to their contact surface, substantially corresponding with the N-S direction of the permanent magnets and only offer limited to no resistance against a mutual shift in a direction toward or parallel with the plane of the panels. This means the panels are firmly 7 fixed to the frames via the coupling parts 4,8 as soon as the panels are placed on the corresponding frame 2 but can still easily be shifted in a lateral direction relative to the frame for a good alignment both mutually and relative to the frame to which they are attached. No other fasteners are provided to attach the panels to the corresponding frames.

[0028] Figure 3 schematically shows a front view of the partial wall cladding with the panels 7 attached to the frames 2 and aligned. The panels 7 and frames 2 are configured and aligned with each other such that each panel 7 extends at least up to the outer edge of the corresponding frame 2 and as such completely covers the front side of the frame. The connecting elements 6 are oblong and their width is aligned, taking into account the depth of the grooves in which they are applied, with the dimensions and positioning of frames 2 and panels 7 such that in completely mounted condition of the wall cladding, adjacent frames 2 do not touch each other and adjacent panels 7 do not touch each other. This configuration ensures that the panels lie in practically one plane and that sufficient tolerance is incorporated in the relative distance such that panels do not touch each other in case of any thermal expansion under the influence of varying environmental conditions.

[0029] Figure 4 shows a cross-section of a profile of a frame 2 with a panel 7 attached thereto on the level of a permanent magnet 4. The panel 7 is attached to the frame by the magnetic attraction between the permanent mag-

nets 4 which are attached to the frame and the steel strips 8 attached to the panel 7. A rubber strip 5 is applied between the profile of the frame and the panel which substantially extends up to the outer wall of the profile, or the outer edge of the frame. The rubber strip is inserted in an opening in the front wall of the profile, or the front side of the frame. Furthermore, a groove 9 is provided in the outer edge of the frame in which a connecting element 6 can be applied. The groove 9 has a bottom and two opposite sidewalls that delimit the groove on the upper-side and underside respectively. The exposed surface of the frame profile on the upper-side and underside of the groove 9 has a profiled surface 10. The surface profile 10 consists of a sequence of dams and grooves. Preferably, the connecting element is configured such that, when inserted in the groove, the surface sections of the connecting element opposite the sidewalls of the groove are flat. This allows the connecting element 6 to be slid in the grooves 9 with little friction and substantially fittingly and moreover, in mounted condition the barrier against water seeping in or moist air penetrating via the grooves is increased.

[0030] Figure 5 shows a composite wall 1 to which frames and corresponding panels 7 are magnetically attached via permanent magnets on the frame 4 and steel strips applied on the rear side of the panels 7. There are no visible attachment parts. In the grooves provided in the outer edges of the frames, connecting elements 6 are applied between adjacent panels. The configuration also allows composite walls with inner corners and outer corners to be provided with wall cladding without loss of functionality and aesthetically forming one whole. To this end, different connecting elements are provided according to the invention, in the form of a flat aluminium slat 6a, an L-shape, such as an inner corner 6b and outer corner 6c, or a T-shape 6d, respectively. Moreover, the configuration is chosen such that the respective connecting elements 6a, 6b, 6c, 6d do not touch the panels 7 and furthermore there is still sufficient tolerance for expansion of the panels due to environmental variations.

[0031] The present invention is by no means limited to the embodiments described as an example and shown in the drawings, but a wall cladding according to the invention can be realised in all kinds of forms and dimensions, without departing from the scope of the invention.

Claims

1. Wall cladding comprising several frames (2) and several panels (7), whereby each frame is composed of profiles with a front wall and rear wall, respectively on the front side and on the rear side of the frame, an inner wall and an outer wall, respectively on the inner edge and on the outer edge of the frame, and whereby against the front side of each frame at least one of the panels (7) is applied, hereby at least partially covering the front side of the frame (2), **char-**

- acterised in that** the wall cladding further comprises at least one connecting element (6) that can be slid in, the outer wall of the profiles all around the frame is provided with a groove (9) in which the connecting element (6) is slid for connecting adjacent frames (2), and each panel on the corresponding frame is attached solely by means of at least one or more first coupling parts (8) which are attached to the panel and by one or more cooperating second coupling parts (4) which are attached to the profiles, whereby the first coupling parts and the second coupling parts are provided to magnetically attract or reject each other, in such a way that a mutual shift of the panel relative to the frame is possible in a direction parallel to the plane of the panel.
2. Wall cladding according to claim 1, **characterised in that** a rubber strip (5) is applied between each frame (2) and corresponding panel or panels (7).
3. Wall cladding according to claim 2, **characterised in that** the rubber strip (5) between each frame (2) and corresponding panel or panels (7) is applied around the entire frame.
4. Wall cladding according to any one of the previous claims, **characterised in that** the rubber strip (5) between each frame (2) and corresponding panel or panels (7) is applied around the entire frame substantially up to the outer edge of the frame.
5. Wall cladding according to any one of the previous claims, **characterised in that** each panel (7) completely covers the front side of the corresponding frame (2).
6. Wall cladding according to any one of the previous claims, **characterised in that** the at least one or more first coupling parts (8) are steel strips.
7. Wall cladding according to any one of the previous claims, **characterised in that** the at least one connecting element (6) is oblong, and wide such that when applied between two adjacent frames (2) said frames do not touch each other and the respective panels (7) attached to said adjacent frames do not touch each other either.
8. Wall cladding according to any one of the previous claims, **characterised in that** the connecting element (6) and the panels (7) do not touch each other.
9. Wall cladding according to any one of the previous claims, **characterised in that** the at least one connecting element (6) is flat (6a), T-shaped (6d), or L-shaped (6b,6c).
10. Wall cladding according to any one of the previous claims, **characterised in that** a section of the surface of the profile in the groove (9) has a surface profile (10) of alternating grooves and dams.
11. Wall cladding according to claim 10, **characterised in that** the section of the connecting element (6) which, when the connecting element (6) is applied in the groove (9), is located opposite the surface profile (10) has a flat surface.
12. Wall cladding according to any one of the previous claims, **characterised in that** the connecting element (6), the profiles of the frames (2), and the panels (7) are made from aluminium.

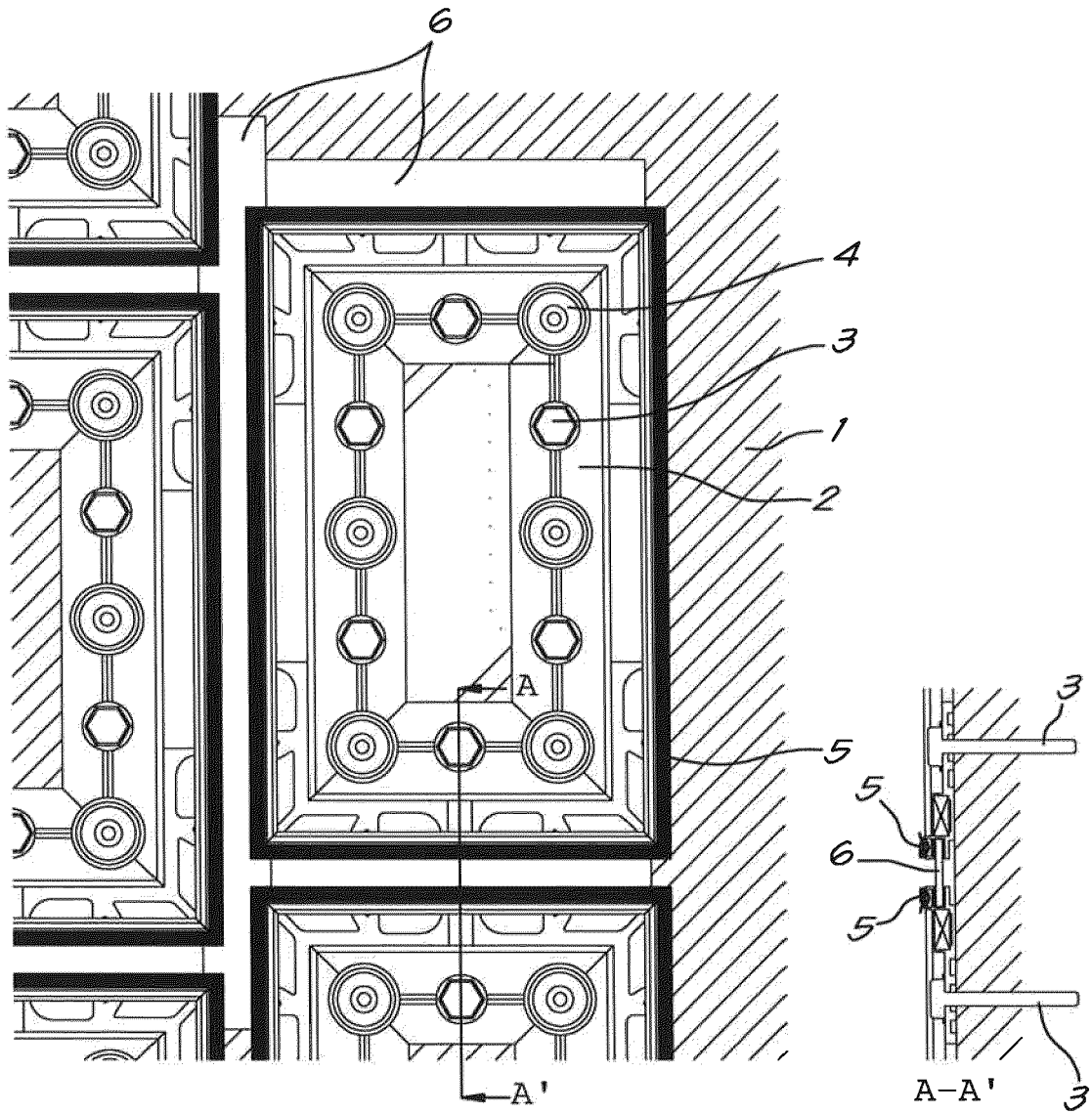

Fig. 1

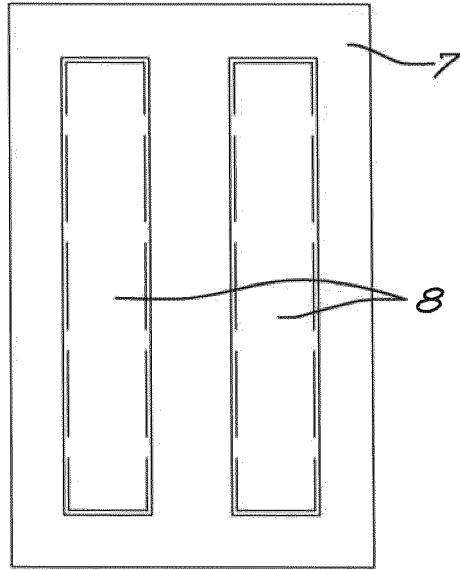

Fig. 2

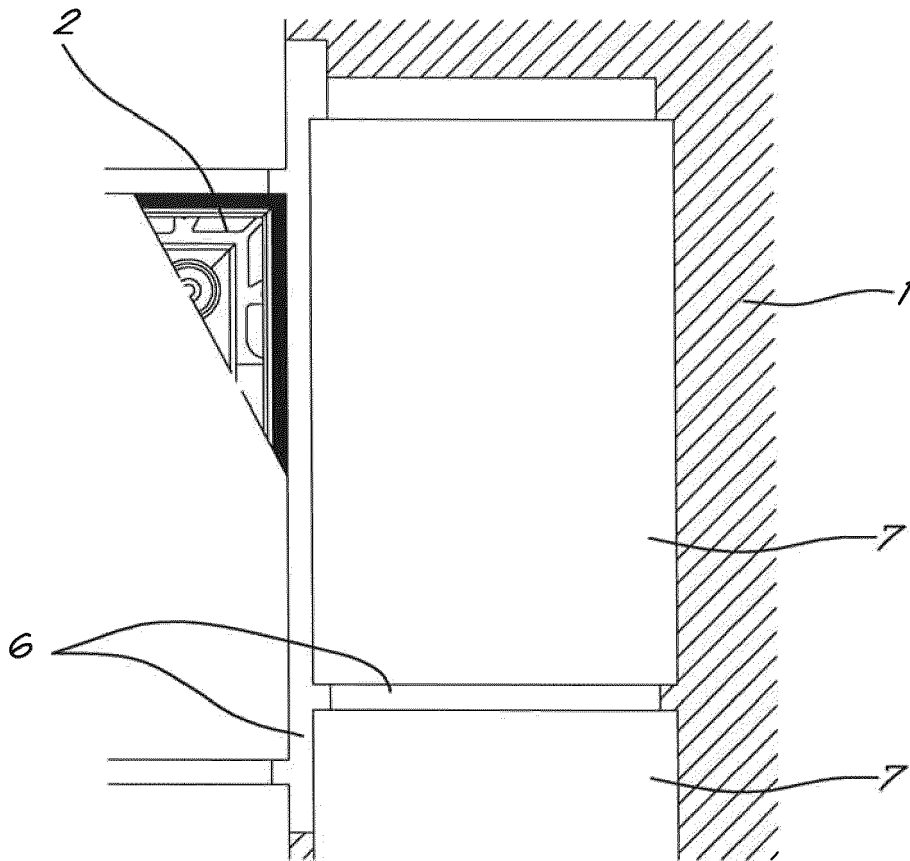

Fig. 3

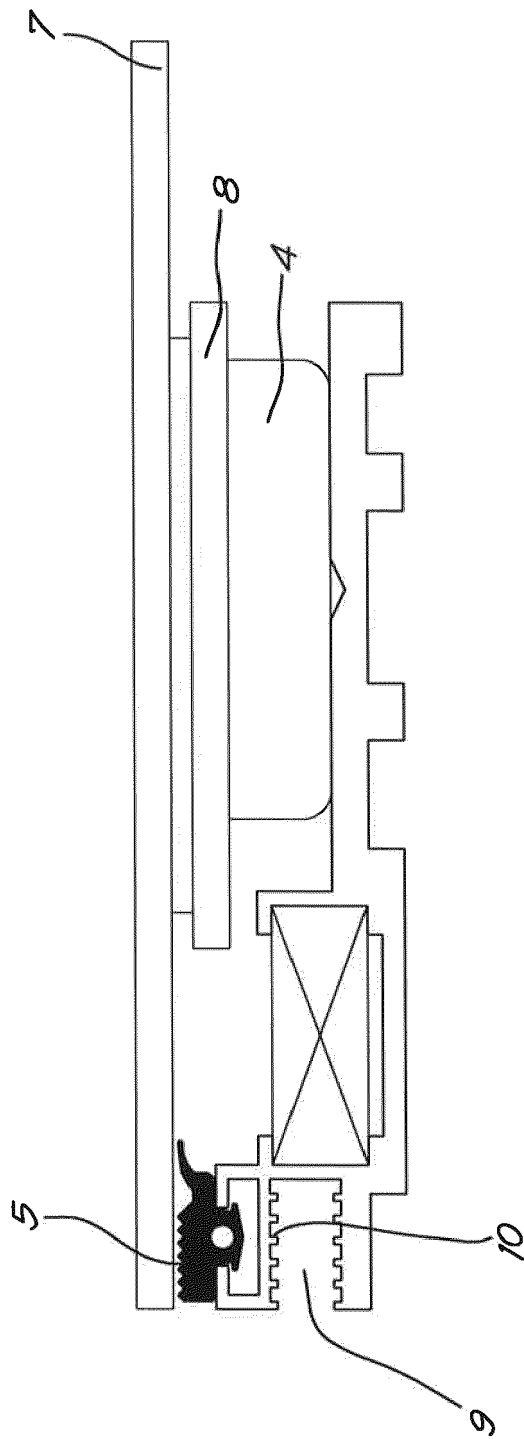
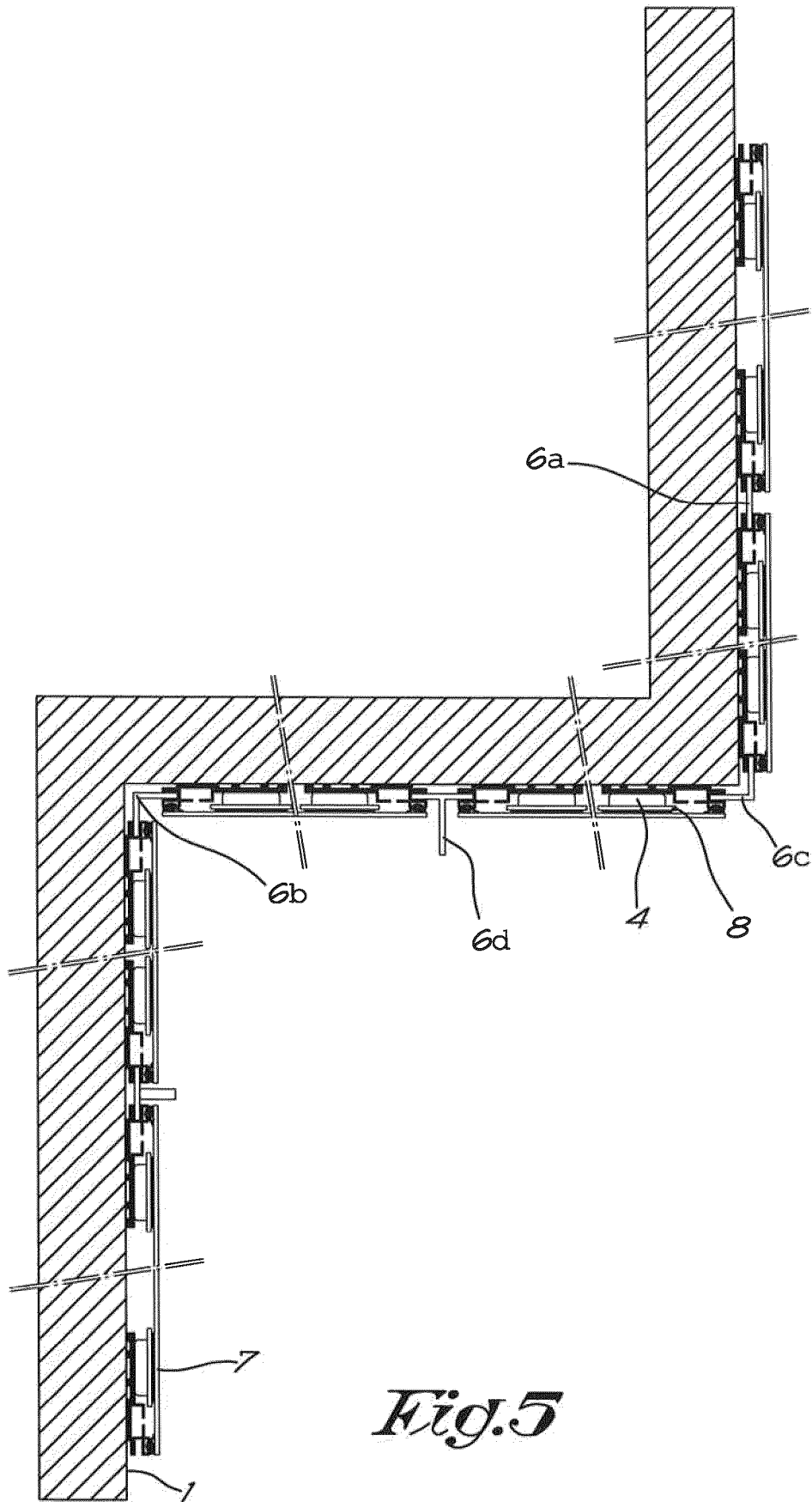

Fig. 4





EUROPEAN SEARCH REPORT

Application Number

EP 23 18 8028

5

10

15

20

25

30

35

40

45

50

55

DOCUMENTS CONSIDERED TO BE RELEVANT			
Category	Citation of document with indication, where appropriate, of relevant passages	Relevant to claim	CLASSIFICATION OF THE APPLICATION (IPC)
X	KR 2013 0021208 A (SHIM SANG MI [KR]) 5 March 2013 (2013-03-05)	1, 5, 7-9	INV. E04F13/08
Y	* figures 2-3, 5 * * paragraph [0021] - paragraph [0027] * -----	2-4, 6, 10-12	
Y	CN 113 775 128 A (SHANGHAI LANTIAN BUILDING DECORATION ENG CO LTD) 10 December 2021 (2021-12-10) * figure 1 * * paragraph [0034] * -----	2-4, 12	
Y	US 3 982 370 A (BUFFINGTON DONALD R) 28 September 1976 (1976-09-28) * figure 2 * * column 3, line 12 - line 15 * -----	6	TECHNICAL FIELDS SEARCHED (IPC) E04F
Y	US 2017/093106 A1 (HOCHMAN JEREMY [US] ET AL) 30 March 2017 (2017-03-30) * figures 1A-1B * * paragraph [0049] * -----	10, 11	
The present search report has been drawn up for all claims			
Place of search Munich		Date of completion of the search 7 September 2023	Examiner Estorgues, Marlène
CATEGORY OF CITED DOCUMENTS X : particularly relevant if taken alone Y : particularly relevant if combined with another document of the same category A : technological background O : non-written disclosure P : intermediate document T : theory or principle underlying the invention E : earlier patent document, but published on, or after the filing date D : document cited in the application L : document cited for other reasons & : member of the same patent family, corresponding document			

1
EPO FORM 1503 03:82 (P04C01)

ANNEX TO THE EUROPEAN SEARCH REPORT
ON EUROPEAN PATENT APPLICATION NO.

EP 23 18 8028

5 This annex lists the patent family members relating to the patent documents cited in the above-mentioned European search report.
The members are as contained in the European Patent Office EDP file on
The European Patent Office is in no way liable for these particulars which are merely given for the purpose of information.

07-09-2023

Patent document cited in search report	Publication date	Patent family member(s)	Publication date
KR 20130021208 A	05-03-2013	NONE	

CN 113775128 A	10-12-2021	NONE	

US 3982370 A	28-09-1976	CA 956772 A	29-10-1974
		US 3982370 A	28-09-1976

US 2017093106 A1	30-03-2017	CN 106558291 A	05-04-2017
		EP 3147770 A1	29-03-2017
		EP 3147771 A1	29-03-2017
		EP 3148006 A1	29-03-2017
		JP 6836838 B2	03-03-2021
		JP 2017062454 A	30-03-2017
		KR 20170037485 A	04-04-2017
		TW 201712650 A	01-04-2017
		US 9477438 B1	25-10-2016
		US 2017093106 A1	30-03-2017
