



(11)

EP 4 349 428 A1

(12)

EUROPEAN PATENT APPLICATION
published in accordance with Art. 153(4) EPC

(43) Date of publication:

10.04.2024 Bulletin 2024/15

(51) International Patent Classification (IPC):

A63B 21/072 ^(2006.01)

(21) Application number: **22810702.5**

(52) Cooperative Patent Classification (CPC):

A63B 21/00; A63B 21/072

(22) Date of filing: **20.05.2022**

(86) International application number:

PCT/ES2022/070310

(87) International publication number:

WO 2022/248750 (01.12.2022 Gazette 2022/48)

(84) Designated Contracting States:

**AL AT BE BG CH CY CZ DE DK EE ES FI FR GB
GR HR HU IE IS IT LI LT LU LV MC MK MT NL NO
PL PT RO RS SE SI SK SM TR**

Designated Extension States:

BA ME

Designated Validation States:

KH MA MD TN

(71) Applicant: **Ramia Vidal, Manlio Elias**

08901 Hospitalet de Llobregat (Barcelona) (ES)

(72) Inventor: **Ramia Vidal, Manlio Elias**

08901 Hospitalet de Llobregat (Barcelona) (ES)

(74) Representative: **Espiell Gomez, Ignacio**

R. Volart Pons y Cia., S.L.

Pau Claris, 77 2^a 1^a

08010 Barcelona (ES)

(30) Priority: **25.05.2021 ES 202131065 U**

(54) **ACCESSORY FOR WEIGHTS**

(57) The present invention relates to an accessory for weights that can be used on one or two dumbbells (2) which are formed by a steel bar (3) with interchangeable discs (4) that are attached by fasteners (5) close to the ends on both sides of the same bar. The accessory comprises at least one tubular part (10, 11, 12, 13, 14, 15, 19, 20, 21, 22, 23, 24, 25, 26, 27, 29, 30, 32, 33, 34, 35,

36, 37, 40) with a varying configuration, preferably being made of metal, which in turn comprises at least one hand gripping element (16) or foot gripping element (17), and attachment means (18) which enable and secure the coupling thereof to at least one bar (3) of one dumbbell (2) in a removable manner.

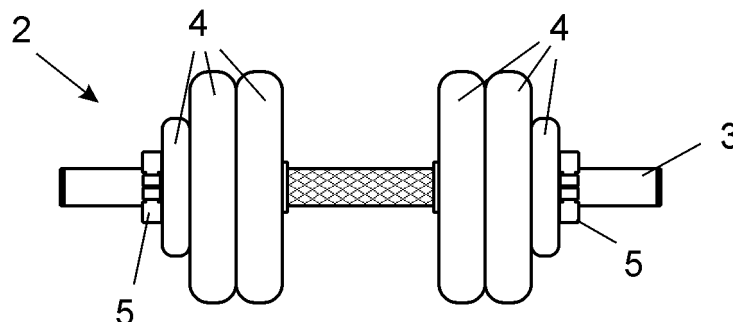

FIG. 1

Description**OBJECT OF THE INVENTION**

[0001] The invention, as stated in the title of the present specification, relates to an accessory for weights that contributes advantages and features to the function intended, which are described in detail further on.

[0002] The object of the present invention lies in an accessory made up of at least one gripping part with a varying configuration that is particularly designed to enable the incorporation thereof to the bar of a weight in a removable manner and, where appropriate, being interchangeable between different models thereof, particularly a dumbbell formed by a bar and interchangeable discs, providing the possibility of expanding the way it is held and, with it, the range of muscular exercises to be performed, avoiding having to have different types of weights.

FIELD OF APPLICATION OF THE INVENTION

[0003] The field of application of the present invention falls within the sector of the industry dedicated to the manufacture of gym apparatuses, focusing particularly on the field of weights and more specifically on accessories for same.

BACKGROUND OF THE INVENTION

[0004] As is known, the most commonly used weights that take up the least space, especially in the private sector but also in gyms or sports facilities, are dumbbells. However, the muscular exercises that can be performed with them, formed by simply a bar with weights on both sides, are limited, since, on the one hand, the length of the bar is short, as it is designed to be held with a with just one hand and, at most, the weights are interchangeable to increase or decrease the force to be lifted, for example in the case of plates or discs that are incorporated at the ends and attached by means of collars or security clamps.

[0005] This means that when the user wants to perform other exercises, it is necessary to use other apparatuses or different weights, which leads to an increase in the space occupied and also an increase in the acquisition cost.

[0006] The objective of the present invention is, therefore, to provide the market with an accessory element that enables the possibilities of use of the dumbbells to be modified and expanded so that, simply by adding one of the models of the accessory, different bodybuilding exercises can be performed with the same dumbbell, either with one or both hands or even with feet.

[0007] Furthermore, and as a reference to the current state of the art, it should be noted that at least the applicant is unaware of the existence of any other accessory for weights, or any other invention of similar application,

which presents technical and structural features that are the same or similar to those presented by the accessory which is claimed herein.

DESCRIPTION OF THE INVENTION

[0008] The accessory for weights proposed by the invention is configured as the ideal solution to the aforementioned objective, the characterizing details that make it possible and that distinguish it being conveniently included in the final claims that accompany this description.

[0009] Specifically, what the invention proposes, as noted above, is an accessory for muscle training weights which, made up of at least one gripping part with a varying configuration, is particularly designed to be able to be incorporated in a removable manner to the bar of a dumbbell, and where appropriate to be able to exchange it between different models thereof, preferably a dumbbell formed by a steel bar and interchangeable plates or discs, providing the possibility of expanding the way the dumbbell is held and, with it, being able to perform different types of muscular exercises, with the advantage of avoiding the need to have different types of weights or apparatuses to perform said exercises, as well as taking up less space.

[0010] To this end, and more specifically, the accessory for weights object of the invention is essentially configured from at least one tubular part, preferably being made of metal, comprising at least one hand or foot gripping element and attachment means that enable it to be attached to the bar of the dumbbell in a removable manner.

[0011] And, based on said general characteristics, the accessory of the invention presents various embodiment options intended to provide different possibilities of use, in addition to using just one hand as is usually the case, either with two hands or with one or both feet, to perform a number of different bodybuilding exercises.

[0012] Thus, in one embodiment, the described accessory comprises two straight tubular parts with respective hand gripping elements and coaxial coupling to the respective ends of the bar, on the outer part of the position of the discs, so that the length thereof is prolonged, enabling the use of the dumbbell as a bar for lifting weights.

[0013] In another embodiment variant, the accessory of the invention comprises two angular tubular parts with respective hand gripping elements and angled coupling to the respective ends of the bar, on the outer part of the discs so that, at the same time that the length of the bar is prolonged, the angle of gripping same with both hands is modified, enabling it to be used as an angled bar for weights.

[0014] In another embodiment, the accessory comprises a single tubular part that can be coupled to the central part of the bar of the dumbbell that defines a Y-shaped configuration with two hand gripping elements that are symmetrical and angled with respect to the axis of the bar for holding the dumbbell with both hands.

[0015] In another embodiment, the accessory comprises a single tubular part that can be coupled to the central part of the bar of the dumbbell defining a T-shaped configuration with two hand gripping elements that are parallel to the axis of the bar for holding the dumbbell with both hands.

[0016] In another embodiment variant, the accessory comprises a single tubular part that can be coupled to the central part of the bar of the dumbbell defining a U-shaped configuration, having two hand gripping elements that are parallel to one another and perpendicular to the axis of the bar for holding the dumbbell with both hands.

[0017] In another embodiment, the accessory comprises one or two parts, that can be coupled respectively either to the central part of the bar of the dumbbell or to the respective ends of the bar, on the outer part of the discs, defining a configuration in the form of a frame with a central gripping element parallel to the axis of the bar to introduce the foot, along the instep, so that the dumbbell can be lifted with one or both legs at the same time.

[0018] Continuing with the characteristics of the accessory of the invention, in another embodiment option, it comprises two tubular parts configured with an articulated end with a hand grip that enables it to be positioned in different positions, as desired, so that with a single accessory it is possible to achieve the three fixed positions already described.

[0019] In another embodiment option for the accessory of the invention, it is made up of a single tubular part with a branched configuration with articulated ends with a hand grip for the central coupling thereof to the bar of the dumbbell such that it enables said ends to be positioned in different positions, as desired.

[0020] In another embodiment of the invention, the accessory comprises two tubular parts with a branched configuration with two fixed branches each provided with a hand grip for the coaxial coupling thereof to each end of the bar of the dumbbell, such that the user can use either of the grips, depending on the type of exercise to be performed, without having to change the accessory.

[0021] In another embodiment of the accessory, it comprises a tubular part in the form of a long bar with various configurations and attachment means at both ends thereof, being intended in this case for the sandwiched coupling thereof between the respective bars of two dumbbells, enabling them to be converted into a bench or shoulder weight apparatus.

[0022] Optionally, the tubular part in the form of a bar may comprise an anchoring ring for inserting the cable of a pulley and enabling the use thereof in a pulley weight machine.

[0023] In another embodiment option, the tubular part that it comprises is also intended for the sandwiched coupling thereof between two dumbbells, having a rectangular frame shape which is flat or has a central bend, and several hand gripping elements integrated between the longer sides thereof, in different number and arrange-

ment options, that is, oblique and/or perpendicular, to be able to hold the assembly with both hands perpendicular or practically perpendicular to the axial axis of the bars of the dumbbells and to be able to do so with greater or lesser separation, depending on the exercise to be performed.

[0024] Optionally, the tubular part in the form of a rectangular frame may comprise a perforated attachment appendage to insert the end of a long bar for weights and be able to perform exercises with same resting on the floor at the opposite end.

[0025] In another embodiment option, the tubular part has a configuration in the form of a closed or open hexagonal frame, suitable for the user to pass their body through same and hold it with respective hand gripping elements provided on both sides of the interior of said frame to do different exercises.

[0026] In another embodiment option for the accessory, the tubular part has an overturned C shape, a V shape, a double TT shape or an oblique double TT shape and has attachment means for the centered coupling thereof between the bars of two dumbbells.

[0027] Continuing with the characteristics of the invention, the accessory may comprise two or more straight or oblique additional parts with a hand grip and attachment for the coupling thereof at some point of the tubular part in the form of a bar for coupling between two dumbbells, enabling them to be positioned in different positions, as preferred and depending on the exercise to be performed.

[0028] Finally, in another embodiment, the part has a configuration in the form of an ankle with foot gripping means on the interior thereof, enabling it to be attached either in the center of the dumbbell or at the ends thereof.

[0029] Preferably, in any of the embodiment options described, the hand gripping elements comprised in the different parts incorporate a cover made of a non-slip material, for example rubber, to make the use of the dumbbell safer with said accessory incorporated.

[0030] In turn, in the embodiment option in which the part or parts of the accessory comprise a foot gripping element, this preferably incorporates a plush and/or padded material to minimize the hardness of the metal and make the contact of the tube with the foot softer.

[0031] In turn, in a preferred embodiment, the attachment means that enable the removable coupling of the parts to the bar of the dumbbell consist of a clamp for adjustment by means of screwing, enabling the attachment of the part or parts both in the central part as well as at the ends of the bar of the dumbbell.

[0032] However, when the accessory comprises parts that can be coupled to the ends of the bar of the dumbbell, the attachment means that enable the removable coupling of the parts preferably consist of a hollow cylinder section provided with at least one tightening grub screw and has a diameter suitable for internally receiving the end of the bar of the dumbbell.

[0033] Therefore, the accessory advantageously the

possibility of performing different types of exercises with one or two dumbbells without having to have another type of bar. Furthermore, the user will be able to have one, two or more of the different embodiment options described that the accessory may present to be able to put on or take off the one they prefer each time, being able to do six or seven different exercises with a single dumbbell, in addition to those that can be done with the dumbbell itself, and many others in the case of the options which can be used for incorporation between two dumbbells.

[0034] The accessory is, therefore, ideal for exercises at home as well as in gyms, since it replaces other exercises that can also be done on a pulley, but without ruling out its coupling to same.

DESCRIPTION OF THE DRAWINGS

[0035] To complete the description, and for the purpose of helping to make the features of the invention more readily understandable, this description is accompanied by a set of drawings constituting an integral part of the same, which by way of illustration and not limitation represents the following:

Figure 1 shows a schematic front elevational view of an exemplary dumbbell for which the accessory for weights object of the invention is intended, where its appearance and parts for conventional use can be seen;

Figure 2 shows a front elevational view of the dumbbell shown in Figure 1 incorporating an exemplary accessory for weights object of the invention, specifically an exemplary first embodiment option comprising two symmetrical gripping parts coaxial to the bar, where the coupling thereof to the respective ends of the bar can be seen;

Figure 3 shows a front elevational view of the two parts making up the exemplary option for the accessory of the invention shown in Figure 2, where the configuration thereof separately from the dumbbell can be seen;

Figures 4 and 5 show elevational views, from the respective sides, of one of the parts of the variant of the accessory shown in Figure 3;

Figure 6 shows a front elevational view of the dumbbell incorporating an exemplary second embodiment option for the accessory of the invention, in this case made up of two gripping parts angled with respect to the axial axis of the bar which can be coupled to both ends thereof;

Figure 7 shows a front elevational view of the two parts making up the accessory, according to the exemplary option shown in Figure 6;

Figure 8 shows a front elevational view of the dumbbell incorporating an exemplary third embodiment option for the accessory of the invention, in this case made up of a single part for central coupling to the

bar with respective V-shaped gripping elements; Figure 9 shows a front elevational view of the part making up the accessory of the invention, according to the option shown in Figure 8, depicted separately from the dumbbell;

Figures 10 and 11 show two front elevational views of the dumbbell incorporating, respectively, embodiment options for the accessory of the invention, specifically an exemplary option made up of a single part for central coupling with two gripping elements parallel to the bar in Figure 10, and an option made up of a single part for central coupling with two gripping elements parallel to each other and perpendicular to the bar in Figure 11;

Figures 12 and 13 show, respectively, a front elevational view of the dumbbell incorporating another exemplary embodiment option for the accessory and for said accessory depicted separately from the dumbbell, in this case an option comprising a single part for central coupling to the bar with a foot grip; Figure 14 shows a front elevational view of the dumbbell incorporating another exemplar embodiment option for the accessory, in this case an option comprising two parts for coupling to the ends of the bar with a foot grip;

Figure 15 shows a front and side elevational view of the two parts of the accessory, according to the example shown in Figure 14, depicted separately from the dumbbell;

Figure 16 shows a front elevational view of the dumbbell, again incorporating an exemplary embodiment for the accessory of the invention made up of two gripping parts that can be coupled to both ends of the bar configured at an angle with respect to the axial axis of the bar, in this case an example at a right angle or with an L-shaped configuration;

Figure 17 shows a front elevational view of the two parts making up the accessory, according to the exemplary option shown in Figure 16;

Figure 18 shows a front elevational view of another embodiment option for the accessory of the invention, in this case made up of two articulated parts for coupling to the ends of the bar of the dumbbell;

Figure 19 shows a front elevational view of another embodiment option for the accessory of the invention, in this case made up of a single part for central coupling to the bar with articulated ends provided with hand gripping elements;

Figures 20 and 21 show front elevational views of two other embodiment options for the accessory in which it comprises two double-ended tubular parts, at an acute angle and a right angle respectively, for coupling to each end of the bar (3) of the dumbbell (2);

Figures 22, 23, 24 and 25 show respective front elevational views of another embodiment option for the accessory of the invention, in this case with a tubular part in the form of a bar for the sandwiched

coupling thereof between two dumbbells, said part being a straight bar in Figure 22, a U-shaped bent bar in Figure 23, a zig-zag shaped bent bar in Figure 24 and a sinuous curve-shaped bar in Figure 25; Figures 26 to 35 show respective front elevational views of another embodiment option for the accessory of the invention, specifically an option with the tubular part in the form of a flat rectangular frame and coupling sandwiched between two dumbbells, showing said figures. respective variants thereof with integrated hand gripping elements in different numbers and arrangements; Figures 36 to 39 show respective front perspective views of another embodiment option for the accessory of the invention, specifically an option with the tubular part in the form of a flat rectangular frame and coupling sandwiched between two dumbbells, showing said figures. respective variants thereof with integrated hand gripping elements in different numbers and arrangements; Figures 40 and 41 show front elevational views of another embodiment option for the accessory of the invention, specifically an option with the tubular part in the form of a closed and open hexagonal frame, respectively; Figures 42 and 43 show front elevational views of another embodiment option for the accessory, in this case with the U-shaped and V-shaped tubular part, respectively, which can be used for the coupling thereof between two dumbbells; Figures 44 and 45 show two other front elevational views of respective options for the accessory similar to those shown in Figures 42 and 43, specifically with the tubular part in the form of a double TT and in the form of an oblique double TT, respectively; Figures 46 to 49 show examples of the additional tubular part comprising the accessory in a straight and oblique form, respectively, depicted in the position of use incorporated in a dumbbell in Figures 46 and 47, and depicted separately in Figures 48 and 49, where both the straight option and the oblique option have been depicted in front and side elevational views, respectively; and Figures 50 and 51 show another exemplary option for the tubular part of the accessory, in this case in the form of an anklet with a foot grip, Figure 50 showing the coupling thereof to the ends of a dumbbell and Figure 51 showing the separate part in front and side elevational views.

PREFERRED EMBODIMENT OF THE INVENTION

[0036] In view of the aforementioned figures, and in accordance with the adopted numbering, one may observe therein different non-limiting exemplary embodiment options for the accessory for weights of the invention, comprising what is described in detail below.

[0037] Thus, as seen in said figures, the accessory (1)

of the invention, which can be used on a dumbbell (2), preferably a dumbbell (2) formed by a steel bar (3) with interchangeable discs (4) that are attached by appropriate fasteners (5) close to the ends on both sides of the same bar, as shown in Figure 1, essentially comprises:

- at least one tubular part (10, 11, 12, 13, 14, 15, 19, 20, 21, 22, 23, 24, 25, 26, 27, 29, 30, 32, 33, 34, 35, 36, 37, 40) with a varying configuration, preferably being made of metal, which in turn comprises:
 - at least one hand gripping element (16) or foot gripping element (17), and
 - attachment means (18) which enable and secure the coupling thereof to at least one bar (3) of a dumbbell (2) in a removable manner.

[0038] Looking at Figures 2 and 3, it can be seen how, in one embodiment option, the accessory (1) comprises two straight tubular parts (10) with respective hand gripping elements (16) and attachment means (18) at one end of said parts (10) suitable for the coaxial coupling thereof to the respective ends of the bar (3) of the dumbbell (2), on the outer part of the position of the discs (4), so that the length thereof is prolonged on both sides.

[0039] Looking at Figures 6 and 7, it can be seen how, in another embodiment option, the accessory (1) comprises two angular tubular parts (11) with respective hand gripping elements (16) and attachment means (18) at one end of said parts (10) suitable for the coupling thereof to the respective ends of the bar (3) of the dumbbell (2), on the outer part of the position of the discs (4), so that, at the same time that the length of the bar (3) is prolonged, the angle of both ends thereof is modified, in this case forming a right angle.

[0040] Figures 16 and 17 show another previously described exemplary embodiment option where the accessory (1) comprises two angular tubular parts (11), in this case at a right angle or L-shaped, with respective hand gripping elements (16) and attachment means (18) at one end of said parts (10) suitable for the coupling thereof to the respective ends of the bar (3) of the dumbbell (2), on the outer part of the position of the discs (4), so that, at the same time that the length of the bar (3) is prolonged, the angle of both ends thereof is modified, in this case forming a right angle.

[0041] Looking at Figures 8 and 9, it can be seen how, in another embodiment option, the accessory (1) comprises a single tubular part with a V-shaped configuration (12) with two hand gripping elements (16) that are symmetrical and at a divergent angle with respect to the axis of the bar (3) of the dumbbell (2) and attachment means (18) for the coupling thereof to the central part of the bar (3).

[0042] Looking at Figure 10, it can be seen how, in another embodiment variant, the accessory (1) comprises a single tubular part with a T-shaped configuration (13) with two hand gripping elements (16) that are parallel

to the axis of the bar (3) of the dumbbell (2) and attachment means (18) for the coupling thereof to the central part of the bar (3).

[0043] Looking at Figure 11, it can be seen how, in another embodiment option, the accessory (1) comprises a single tubular part with a U-shaped configuration (14) with two hand gripping elements (16) that are parallel to one another and perpendicular to the axis of the bar (3) of the dumbbell and attachment means (18) for the coupling thereof to the central part of the bar (3).

[0044] In Figures 12 to 15, it is seen how, in another embodiment, the accessory comprises one or two parts configured in the form of a quadrangular frame (15) with a foot gripping element (17) parallel to the axis of the bar (3) and attachment means (18) for the coupling thereof either to the central part of the bar (3) of the dumbbell (2) in a unitary manner, as shown in Figures 12 and 13, or for the coupling thereof to the respective ends of the bar (3) of the dumbbell (2), on the outer part of the position of the discs (4).

[0045] Looking at Figure 18, it can be seen how, in another embodiment option for the accessory (1) of the invention, it comprises two tubular parts configured with an articulated end (19), specifically two parts with an articulated end provided with a hand gripping element (16) and a fixed end provided with attachment means (18) for the coaxial coupling thereof to each end of the bar (3) of the dumbbell (2), on the outer part of the position of the discs (4), such that an articulated connection (20) between both ends of the part (19) enables said ends to be positioned with the grips (16) in at least three different positions, one straight to increase the extension of the bar (3), one at an oblique angle and one at a right angle, perpendicular to the bar, as desired, as is the case with the three fixed options shown in Figures 2, 6 and 16 but in the same accessory (1).

[0046] Looking at Figure 19, it can be seen how, in another embodiment option for the accessory (1) of the invention, it is made up of a tubular part with a branched configuration with articulated ends (21) provided with respective hand gripping elements (16), specifically a part with three branches, a central branch with attachment means (18) for the central coupling thereof to the bar (3) of the dumbbell (2), and two lateral branches provided with an articulated connection (20) to the central branch which enables said ends to be positioned with the grips (16) in at least three different positions, forming a Y, a T or a U, as desired, as is the case with the fixed options shown in Figures 8, 10 and 11.

[0047] Looking at Figure 20, it can be seen how, in another embodiment of the invention, the accessory (1) comprises two tubular parts with a branched configuration with two fixed branches at an acute angle (22), specifically two parts with two branches at one end arranged at an acute angle, each provided with a hand gripping element (16) and, at the opposite end, the attachment means (18) for the coaxial coupling thereof to each end of the bar (3) of the dumbbell (2), on the outer part of the

position of the discs (4), such that the user can use either of the grips (16) at each end of the dumbbell (2), depending on the type of exercise to be performed, without the need to change the accessory.

[0048] Looking at Figure 21, another option for the accessory (1) similar to the previous one can be seen, in this case comprising two tubular parts with a branched configuration with two fixed branches at right angles (23), each provided with respective hand gripping elements (16) and attachment means (18) for the coaxial coupling thereof to each end of the bar (3) of the dumbbell (2), on the outer part of the position of the discs (4), such that the user can use either of the grips (16) at each end of the dumbbell (2).

[0049] Looking at Figures 22 to 25, it can be seen how, in another embodiment of the accessory (1), it consists of a tubular part in the form of a long bar (24, 25, 26, 27), that is, longer than the straight tubular part (10) described above, with various configurations and two attachment means (18) at both ends thereof, being intended in this case for the sandwiched coupling thereof between the respective bars (3) of two dumbbells (2) through said attachments (18).

[0050] Specifically, said tubular part in the form of a bar is preferably a straight bar (24), as seen in Figure 22, a U-shaped bent bar (25) (Figure 23), a zig-zag shaped bent bar (26) (Figure 24) and a sinuous curve-shaped bar (27) (Figure 25). Furthermore, in any of its forms, the bar-shaped tubular part (24, 25, 26, 27) includes one or more hand gripping elements (16), preferably two hand gripping elements (16) located symmetrically on both sides of same to hold the assembly and perform bench or shoulder exercises.

[0051] Optionally, the bar-shaped tubular part (24, 25, 26, 27) comprises an anchoring ring (28) integrally joined in the center thereof to insert the cable of a pulley (not shown) and enable the use thereof in a pulley weight machine.

[0052] Looking at Figures 26 to 35, another embodiment option for the accessory (1) of the invention can be seen where the tubular part it comprises is also intended for the sandwiched coupling thereof between the respective bars (3) of two dumbbells (2) through respective attachment means (18) provided at both ends thereof, consisting in this case of a tubular part configured in the form of a flat rectangular frame (29) comprising several hand gripping elements (16) integrated between the longer sides thereof, in different number and arrangement options, that is, oblique and/or perpendicular, to be able to hold the assembly with both hands perpendicular or practically perpendicular to the axial axis of the bars (3) of the dumbbells (2) and with greater or lesser separation, depending on the exercise to be performed.

[0053] Thus, in an embodiment option shown in Figure 26, the tubular part in the form of a flat rectangular frame (29) of the accessory (1) comprises, integrated between the two longer sides thereof, four hand gripping elements (16) perpendicular to the bars (3), which are arranged so

that they are grouped symmetrically in two pairs on both sides of the frame (29).

[0054] In another embodiment option shown in Figure 27, the tubular part in the form of a rectangular frame (29) of the accessory (1) comprises six hand gripping elements (16) perpendicular to the bars (3), grouped in two symmetrical groups of three grips on both sides of the frame (29).

[0055] In another embodiment option shown in Figure 28, the tubular part in the form of a rectangular frame (29) of the accessory (1) comprises eight hand gripping elements (16) perpendicular to the bars (3), grouped in two symmetrical groups of four grips on each side of the frame (29).

[0056] In another embodiment option shown in Figure 29, the tubular part in the form of a rectangular frame (29) of the accessory (1) comprises four hand gripping elements (16) oblique to the bars (3) of the dumbbells, grouped in two symmetrical groups of two grips integrated on both sides of the frame (29).

[0057] In another embodiment option shown in Figure 30, the tubular part in the form of a rectangular frame (29) of the accessory (1) comprises six hand gripping elements (16) oblique to the bars (3) of the dumbbells, grouped in two symmetrical groups of three grips integrated on both sides of the frame (29).

[0058] In another embodiment option shown in Figure 31, the tubular part in the form of a rectangular frame (29) of the accessory (1) comprises eight hand gripping elements (16) oblique to the bars (3) of the dumbbells, grouped in two symmetrical groups of four grips integrated on each side of the frame (29).

[0059] In another embodiment option shown in Figure 32, the tubular part in the form of a rectangular frame (29) of the accessory (1) comprises four hand gripping elements (16) that are perpendicular and two that are oblique to the bars (3) of the dumbbells (2), grouped in two symmetrical groups of three grips integrated on each side of the frame (29), the straight ones at the ends and the oblique ones in the center.

[0060] In another embodiment option shown in Figure 33, the tubular part in the form of a rectangular frame (29) of the accessory (1) comprises four hand gripping elements (16) that are perpendicular and two that are oblique to the bars (3) of the dumbbells (2), grouped in two symmetrical groups of three grips integrated on each side of the frame (29), the oblique ones being sandwiched between the straight ones.

[0061] In another embodiment option shown in Figure 34, the tubular part in the form of a rectangular frame (29) of the accessory (1) comprises four hand gripping elements (16) that are perpendicular and four that are oblique to the bars (3) of the dumbbells (2), grouped in two symmetrical groups of four grips integrated on each side of the frame (29).

[0062] And, in another embodiment option shown in Figure 35, the tubular part in the form of a rectangular frame (29) of the accessory (1) comprises six hand grip-

ping elements (16) that are perpendicular and two that are oblique to the bars (3) of the dumbbells (2), grouped in two symmetrical groups of four grips integrated on each side of the frame (29).

[0063] Looking at Figures 36 to 39, another embodiment option for the accessory of the invention can be seen, specifically an option with the tubular part in the form of a non-flat rectangular frame (30), specifically with a central bend as a bridge, which, being equally used for the sandwiched coupling thereof between the bars (3) of two dumbbells (2) with respective attachment means (18) provided at the ends thereof, comprises several hand gripping elements (16) integrated between the longer sides of said non-flat frame, in different number and arrangement options, that is, oblique and/or perpendicular.

[0064] Thus, in an embodiment option shown in Figure 36, the tubular part in the form of a non-flat rectangular frame (30) comprises three hand gripping elements (16) perpendicular to the longer sides of said frame and the axial axis of the bars (3) of the dumbbells (2), one of which is in the central bent area and the other two arranged one on each side in the areas of the ends of the frame.

[0065] In another embodiment option shown in Figure 37, the tubular part in the form of a non-flat rectangular frame (30) comprises three hand gripping elements (16) arranged symmetrically in a position that is perpendicular and oblique to the longer sides of said frame and the axial axis of the bars (3) of the dumbbells (2), one of which is perpendicular and is in the central bent area and the other two being arranged one on each side in the areas of the ends of the frame, with a convergent inclination.

[0066] In another embodiment option shown in Figure 38, the tubular part in the form of a non-flat rectangular frame (30) comprises three hand gripping elements (16) that are perpendicular and oblique to the bars (3) of the dumbbells (2), one of which is perpendicular and is in the central bent area and the other two being arranged one on each side in the areas of the ends of the frame, with an inclination opposite to the example shown in Figure 37.

[0067] And, in another embodiment option shown in Figure 39, the tubular part in the form of a non-flat rectangular frame (30) comprises five hand gripping elements (16), one of which is in the central bent area and of the other four, two being arranged on each side in the areas at the ends of the frame, with a converging inclination between them.

[0068] Optionally, the tubular part in the form of a flat frame (29) or the one in the form of a non-flat frame (30) of the accessory (1) may comprise a perforated attachment appendage (31) which, as shown in the example in Figure 26, is integrally connected at one side of the center of the part, serving to insert the end of a bar for weights (not shown) and be able to perform exercises with same resting on the floor at the opposite end.

[0069] Looking at Figure 40, another embodiment op-

tion for the accessory (1) can be seen, where the tubular part it comprises, which can be used for the sandwiched coupling thereof between the respective bars (3) of two dumbbells (2) through respective attachment means (18) provided at both ends thereof, is configured in the form of a closed hexagonal frame (32), such that it is suitable for the user to pass their body through same, and has separate hand gripping elements (16) on both sides of the interior of said frame to hold it and do different exercises.

[0070] Figure 41 shows a similar embodiment option where the tubular part it comprises, with attachment means (18) at its ends for the sandwiched coupling thereof between two dumbbells (2), is configured in the form of an open hexagonal frame (33), specifically open on one of its central sides, also having respective hand gripping elements (16) on both inner sides thereof, also serving to surround the user's body while using it in their exercises.

[0071] Looking at Figure 42, another embodiment option for the accessory (1) can be seen, where the tubular part it comprises, which can be used for the sandwiched coupling thereof between the respective bars (3) of two dumbbells (2) through respective attachment means (18), is a tubular part with an overturned C-shaped configuration (34) where the central connecting branch is formed by the attachment means (18) themselves and the side branches comprise separate hand gripping elements (16).

[0072] Figure 43 shows another similar embodiment option for the accessory (1), which can equally be used for the sandwiched coupling thereof between the respective bars (3) of two dumbbells (2) through attachment means (18), in this case being a tubular part with a V-shaped configuration (35) the divergent branches of which comprise the hand gripping elements (16).

[0073] And in Figures 44 and 45, two other embodiment options for the accessory similar to those shown in Figures 42 and 43 can be seen, in this case with the central area being somewhat larger. Specifically, in the example of Figure 44, the accessory comprises a tubular part with a double TT-shaped configuration (36), depicted in an inverted position, where the ends of the connecting branch incorporate the attachment means (18) and the perpendicular branches incorporate the hand gripping means (16). And, in the example of Figure 45, the part is a tubular part in the form of an oblique double TT (37), that is, with oblique instead of perpendicular branches.

[0074] Continuing with the features of the invention, taking into account Figures 46 to 49, it can be seen how the accessory (1) optionally comprises two or more additional parts, specifically additional straight tubular parts (38) or oblique tubular parts (39) defined by a tube segment provided with a hand gripping element (16) and an attachment element (18) in the form of a cylinder or flange at one end, suitable for the coupling thereof to the bar (3) of a dumbbell (2), enabling them to be positioned in different positions at the end of same, as preferred and

depending on the exercise to be performed.

[0075] Finally, Figures 50 and 51 show how, in another embodiment, the accessory comprises one or two tubular parts configured in the form of an anklet (40) with a foot gripping element (17) on the interior thereof and attachment means (18) for the coupling thereof to either the central part of the bar (3) of the dumbbell (2) in a unitary manner or, as shown in Figure 50, for the coupling thereof to the respective ends of the bar (3) of the dumbbell (2), on the outer part of the position of the discs (4). Figure 51 depicts this variant of said part in front and side elevational views, where the configuration it has to adapt to the shape of the user's ankle can be seen.

[0076] On the other hand, the hand gripping elements (16) of the part or parts (10, 11, 12, 13, 14, 19, 20, 21, 22, 23, 24, 25, 26, 27, 29, 30, 32, 33, 34, 35, 36, 37) that the accessory (1) of the invention comprises, as well as the additional parts (38, 39), preferably incorporate a cover made of a non-slip material, for example rubber.

[0077] Likewise, the foot gripping elements (17) of the part or parts (15, 40) of the accessory (1) comprise, incorporated internally, a plush and/or padded material.

[0078] In turn, in one embodiment, the attachment means (18) for the removable coupling of the parts (10, 11, 12, 13, 14, 15, 19, 20, 21, 22, 23, 24, 25, 26, 27, 29, 30, 32, 33, 34, 35, 36, 37, 38, 39, 40) that the accessory (1) comprises to the bar or bars (3) of the dumbbell or dumbbells (2), either in the central part, at the ends of the bar (3) or between two dumbbells (2), consist of a clamp for by means of screwing, as shown in the examples of Figures 8 to 13.

[0079] Optionally, the attachment means (18) for the removable coupling of the parts (10, 11 or 15) that the accessory (1) comprises which can be coupled to the ends of the bar (3) of the dumbbell (2) or of the additional parts (38, 39), consist of a hollow cylinder section provided with at least one tightening grub screw that has a diameter suitable for internally receiving the end of the bar (3) of the dumbbell (2), as can be seen in Figures 2 to 7, especially in Figure 4, as well as in Figures 14 and 15, and in Figures 48 and 49.

[0080] Having sufficiently described the nature of the present invention, as well as the ways in which it may be implemented, it is not considered necessary to elaborate on the explanation thereof in order for a person skilled in the art to understand the scope of the invention and the advantages derived therefrom.

50 Claims

1. An accessory for weights that can be used on one or two dumbbells (2) which are formed by a steel bar (3) with interchangeable discs (4) that are attached by fasteners (5) close to the ends on both sides of the same bar, **characterized by** comprising:

- at least one tubular part (10, 11, 12, 13, 14, 15,

19, 20, 21, 22, 23, 24, 25, 26, 27, 29, 30, 32, 33, 34, 35, 36, 37, 40) with a varying configuration, preferably being made of metal, which in turn comprises:

- at least one hand gripping element (16) or foot gripping element (17), and
- attachment means (18) which enable and secure the coupling thereof to at least one bar (3) of a dumbbell (2) in a removable manner.

2. The accessory for weights according to claim 1, **characterized by** comprising two straight tubular parts (10) with respective hand gripping elements (16) and attachment means (18) at one end of said parts (10) suitable for the coaxial coupling thereof to the respective ends of the bar (3) of the dumbbell (2), on the outer part of the position of the discs (4).
3. The accessory for weights according to claim 1, **characterized by** comprising two angular tubular parts (11) with respective hand gripping elements (16) and attachment means (18) at one end of said parts (10) suitable for the coupling thereof to the respective ends of the bar (3) of the dumbbell (2), on the outer part of the position of the discs (4).
4. The accessory for weights according to claim 1, **characterized by** comprising a single tubular part with a V-shaped configuration (12) with two hand gripping elements (16) that are symmetrical and at a divergent angle with respect to the axis of the bar (3) of the dumbbell (2) and attachment means (18) for the coupling thereof to the central part of the bar (3).
5. The accessory for weights according to claim 1, **characterized by** comprising a single tubular part with a T-shaped configuration (13) with two hand gripping elements (16) that are parallel to the axis of the bar (3) of the dumbbell (2) and attachment means (18) for the coupling thereof to the central part of the bar (3).
6. The accessory for weights according to claim 1, **characterized by** comprising a single tubular part with a U-shaped configuration (14) with two hand gripping elements (16) that are parallel to one another and perpendicular to the axis of the bar (3) of the dumbbell and attachment means (18) for the coupling thereof to the central part of the bar (3).
7. The accessory for weights according to claim 1, **characterized by** comprising two tubular parts configured with an articulated end (19), provided with a hand gripping element (16), and a fixed end provided with attachment means (18) for the coaxial coupling

thereof to each end of the bar (3) of the dumbbell (2), on the outer part of the position of the discs (4).

8. The accessory for weights according to claim 1, **characterized by** comprising a branched tubular part with articulated ends (21), with a central branch having attachment means (18) for the central coupling thereof to the bar (3) of the dumbbell (2), and two lateral branches provided with an articulated connection (20) to the central branch that enables said ends to be positioned with the hand grip (16) in at least three different positions.
9. The accessory for weights according to claim 1, **characterized by** comprising two tubular parts with a branched configuration with two fixed branches at an acute angle (22) or at a right angle (23), each provided with a hand gripping element (16) and attachment means (18) for the coaxial coupling thereof to each end of the bar (3) of the dumbbell (2), on the outer part of the position of the discs (4).
10. The accessory for weights according to claim 1, **characterized by** comprising a tubular part in the form of a bar, a straight bar (24) or a U-shaped bent bar (25) or a zig-zag shaped bent bar (26) or a sinuous curve-shaped bar (27), with two attachment means (18) at both ends thereof, being intended for the sandwiched coupling thereof between the respective bars (3) of two dumbbells (2) through said attachments (18).
11. The accessory for weights according to claim 10, **characterized in that** the tubular part in the form of a bar (24, 25, 26, 27) comprises an anchoring ring (28) integrally joined in the center thereof to insert the cable of a pulley.
12. The accessory for weights according to claim 1, **characterized by** comprising a tubular part configured in the form of a flat rectangular frame (29) or in the form of a non-flat rectangular frame (30) with a central bend in the form of a bridge, comprising several hand gripping elements (16) integrated between the longer sides thereof, in different number and arrangement options, that is, oblique and/or perpendicular, intended for the sandwiched coupling thereof between the respective bars (3) of two dumbbells (2) through respective attachment means (18) provided at both ends thereof.
13. The accessory for weights according to claim 12, **characterized in that** the tubular part in the form of a flat frame (29) or in the form of a non-flat frame (30) comprises a perforated attachment appendage (31) integrally joined thereto to insert the end of a bar for weights.

14. The accessory for weights according to claim 1, **characterized by** comprising a tubular part configured in the form of a closed hexagonal frame (32) or an open hexagonal frame (33), with respective hand gripping elements (16) on both sides of the interior of said frame and which can be used for the sandwiched coupling thereof between the respective bars (3) of two dumbbells (2) through respective attachment means (18) provided at both ends thereof.
15. The accessory for weights according to claim 1, **characterized by** comprising an tubular part with an overturned C-shaped configuration (34) or V-shaped configuration (35), or double TT-shaped configuration (36) or in an oblique double TT-shaped configuration (37), with two branches comprising hand gripping elements (16) and which can be used for coupling between the respective bars (3) of two dumbbells (2) through respective attachment means (18).
16. The accessory for weights according to claim 1 and 10, **characterized by** comprising two or more straight additional parts (38) or oblique additional parts (39), defined by a segment of tube provided with a hand gripping element (16) and an attachment element (18) for coupling to the bar (3) of the dumbbell (2).
17. The accessory for weights according to any of claims 1 to 16, **characterized in that** the hand gripping elements (16) of the part or parts (10, 11, 12, 13, 14, 15, 19, 20, 21, 22, 23, 24, 25, 26, 27, 29, 30, 32, 33, 34, 35, 36, 37, 38, 39 40) incorporate a cover made of a non-slip material.
18. The accessory for weights according to claim 1, **characterized by** comprising one or two parts configured in the form of a quadrangular frame (15) with a foot gripping element (17) parallel to the axis of the bar (3) and attachment means (18) for the coupling thereof either to the central part of the bar (3) of the dumbbell (2) in a unitary manner, or for the coupling thereof to the respective ends of the bar (3) of the dumbbell (2), on the outer part of the position of the discs (4).
19. The accessory for weights according to claim 1, **characterized by** comprising one or two tubular parts configured in the form of an anklet (40) with a foot gripping element (17) on the interior thereof and attachment means (18) for the coupling thereof to either the central part of the bar (3) of the dumbbell (2) in a unitary manner or for the coupling thereof to the respective ends of the bar (3) of the dumbbell (2), on the outer part of the position of the discs (4).
20. The accessory for weights according to claim 1, 18
- or 19, **characterized in that** the foot gripping elements (17) of the part or parts (15) incorporate a plush and/or padded material.
21. The accessory for weights according to any of claims 1 to 9, **characterized in that** the attachment means (18) for the removable coupling of the parts (10, 11, 12, 13, 14, 15, 19, 20, 21, 22, 23, 24, 25, 26, 27, 29, 30, 32, 33, 34, 35, 36, 37, 40) to the bar (3) of the dumbbell (2) consist of a clamp for adjustment by means of screwing.
22. The accessory for weights according to claims 1 and 16, **characterized in that** the attachment means (18) for the removable coupling of the parts (10, 11, 15, 38, 39, 40) that can be coupled to the bar (3) of the dumbbell (2) consist of a hollow cylinder section provided with at least one tightening grub screw that has a diameter suitable for internally receiving the end of the bar (3) of the dumbbell (2).

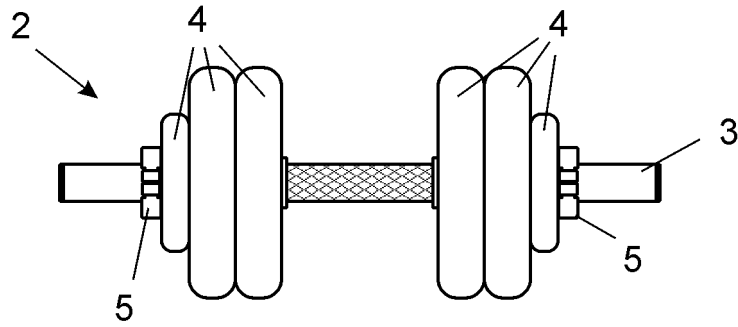

FIG. 1

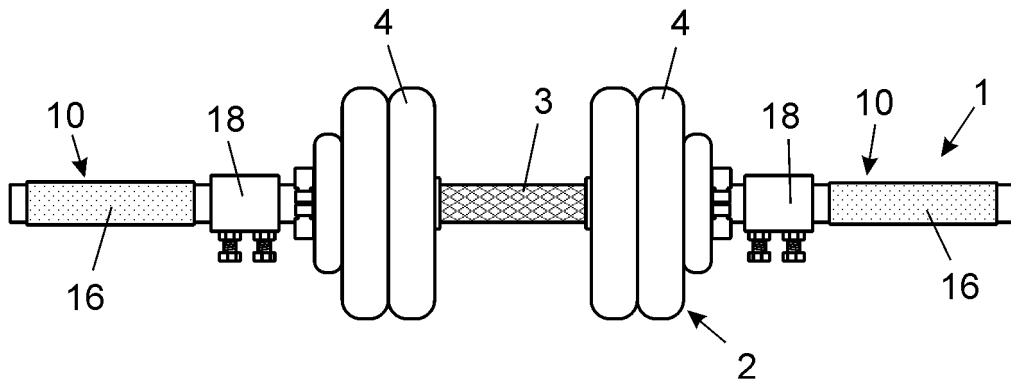

FIG. 2

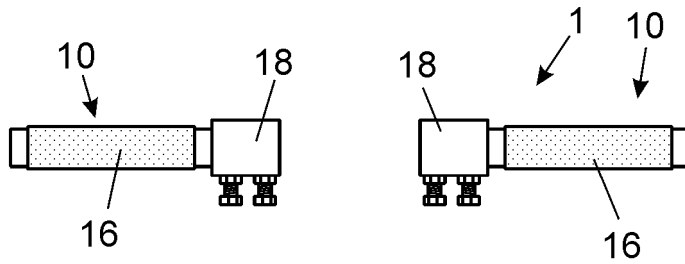

FIG. 3

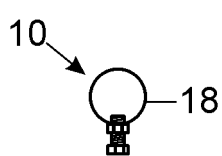

FIG. 4

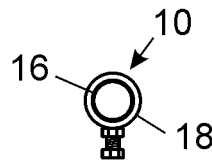

FIG. 5

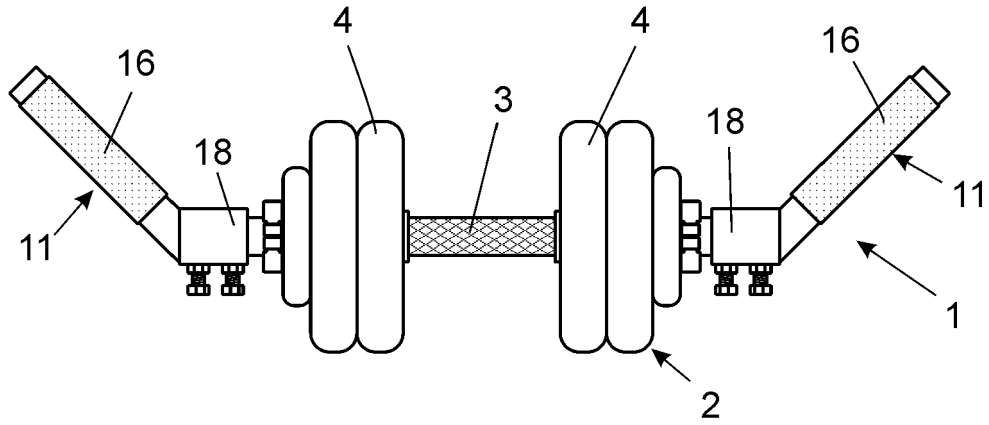

FIG. 6

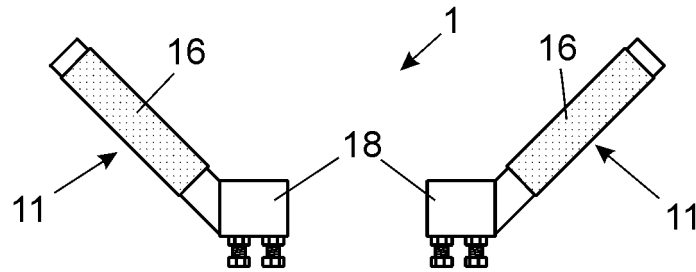

FIG. 7

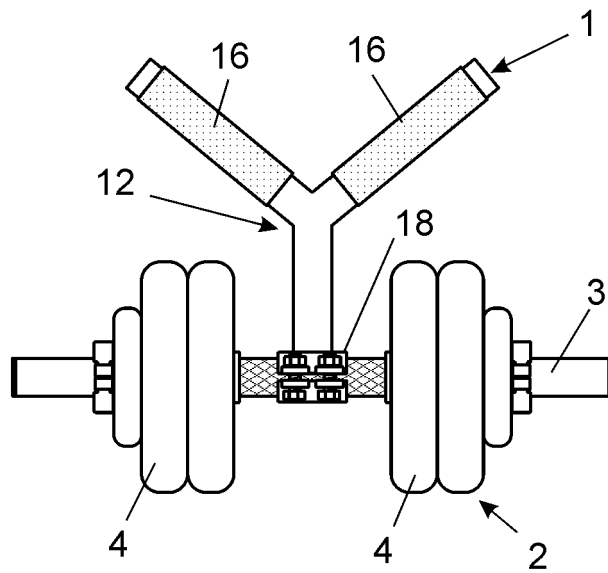

FIG. 8

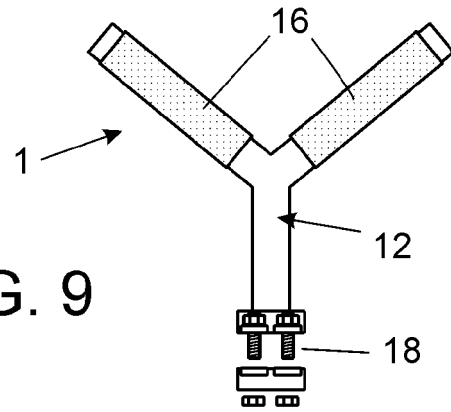

FIG. 9

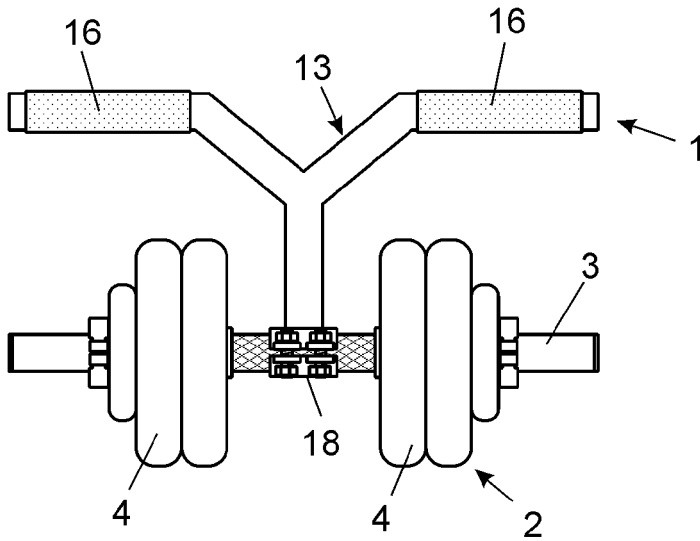

FIG. 10

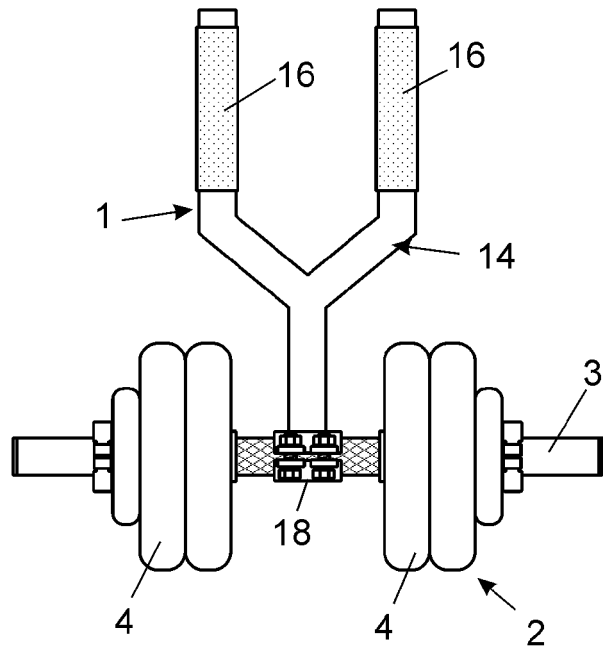

FIG. 11

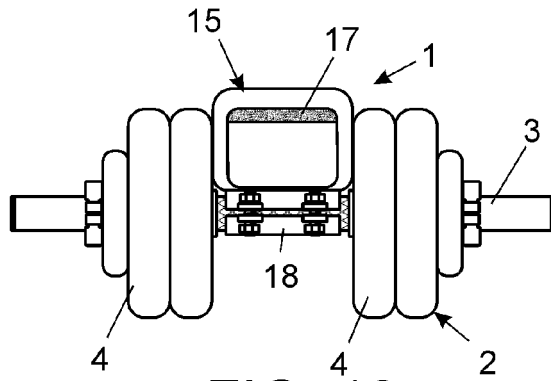

FIG. 12

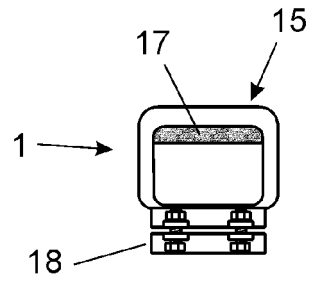

FIG. 13

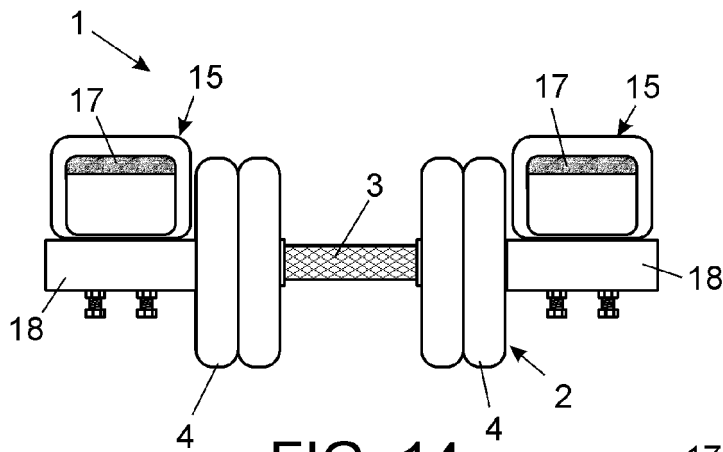

FIG. 14

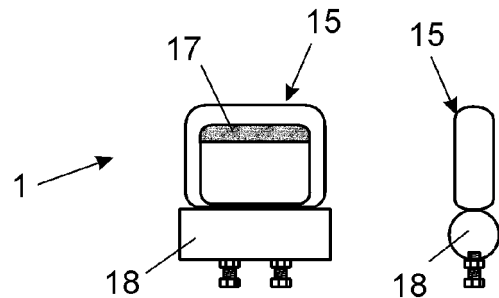

FIG. 15

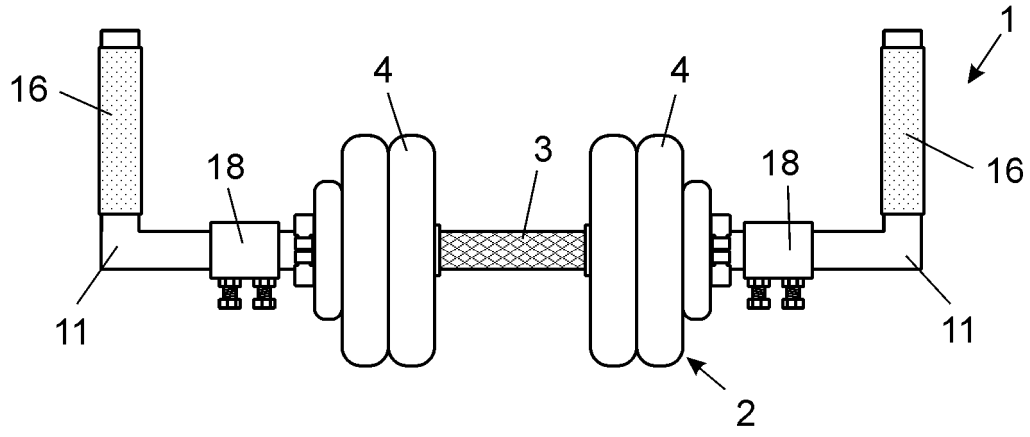

FIG. 16

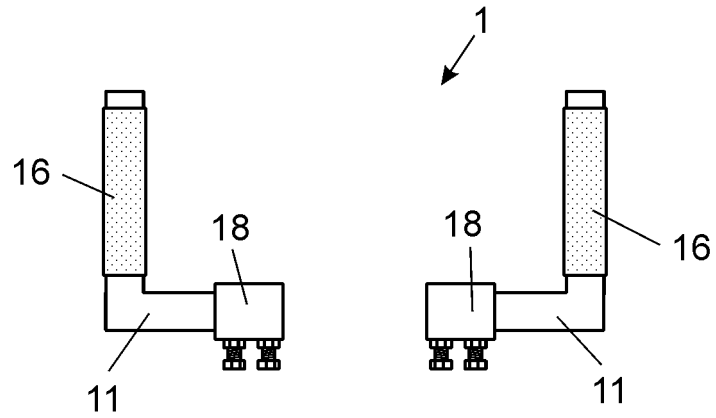

FIG. 17

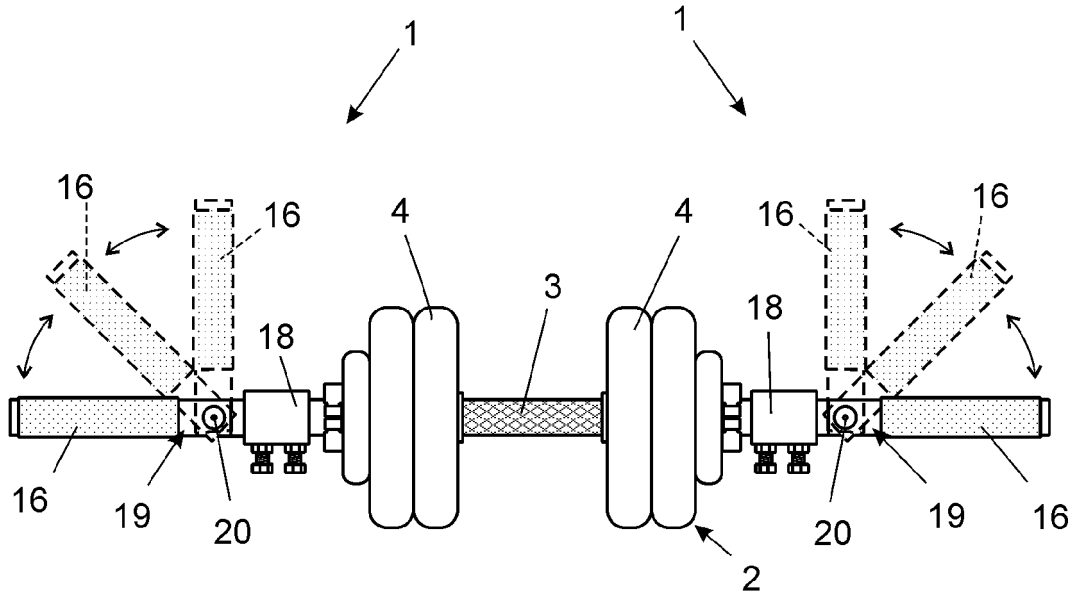

FIG. 18

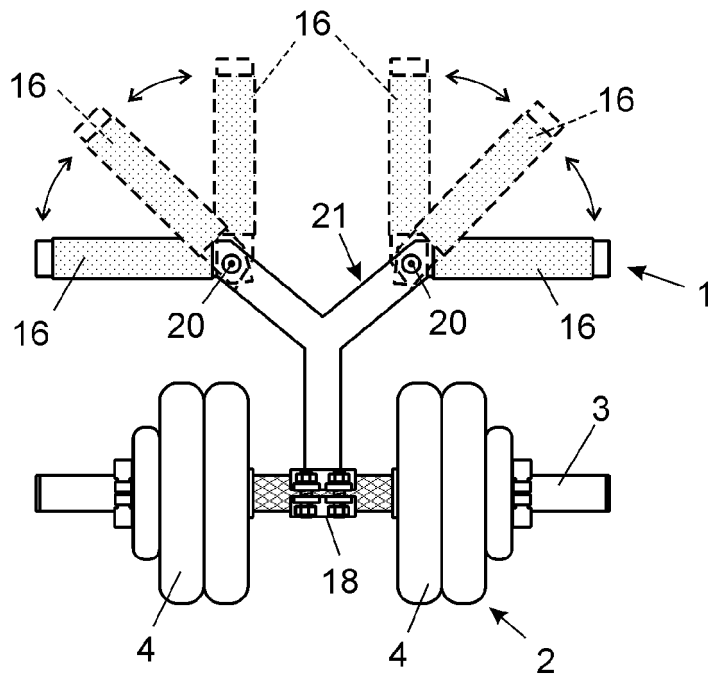

FIG. 19

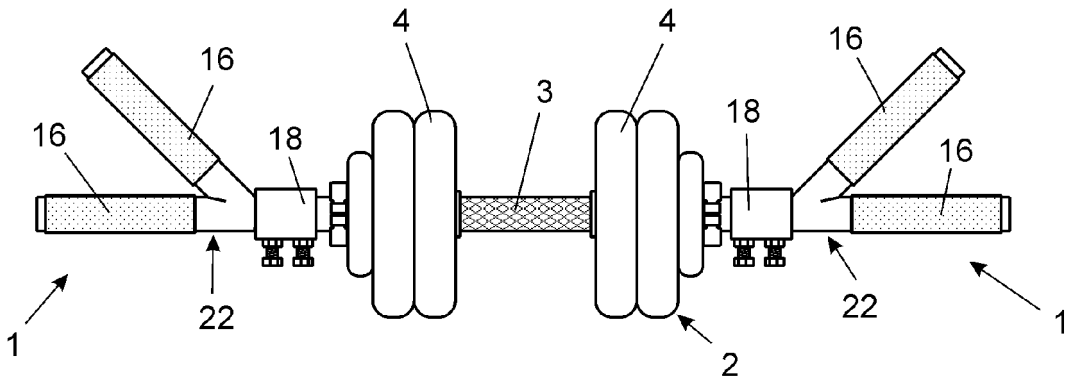

FIG. 20

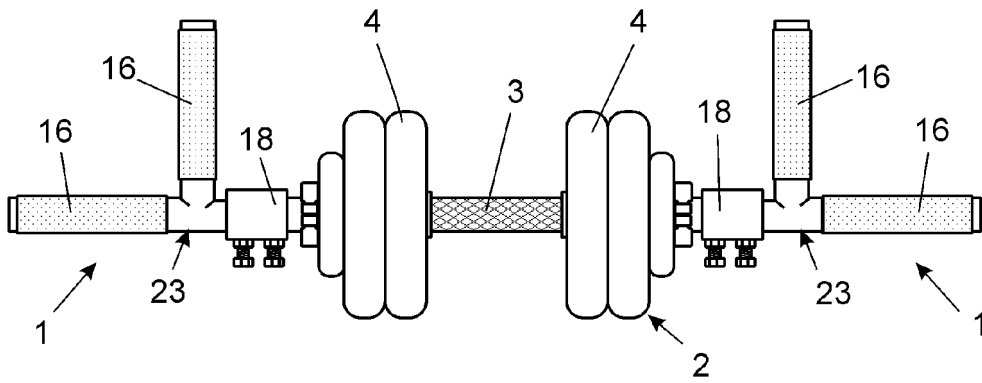

FIG. 21

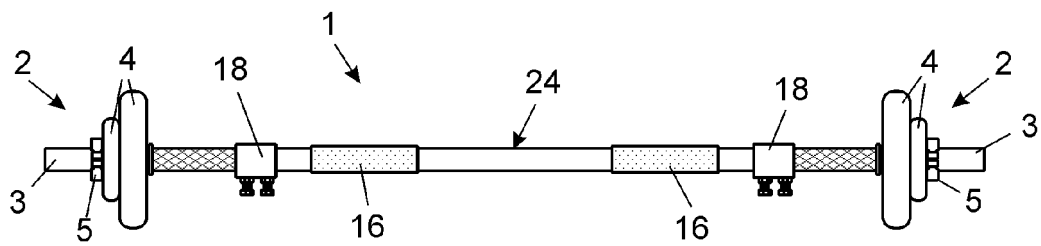

FIG. 22

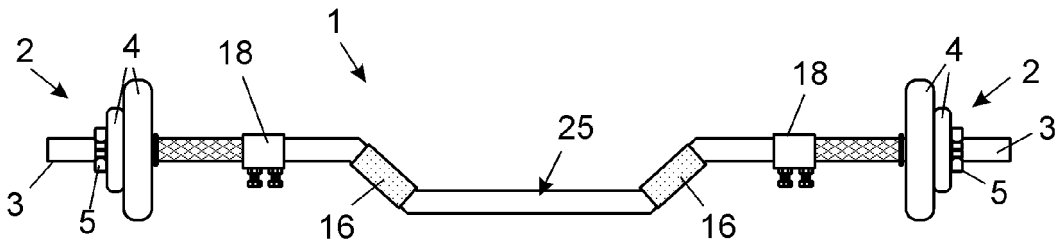

FIG. 23

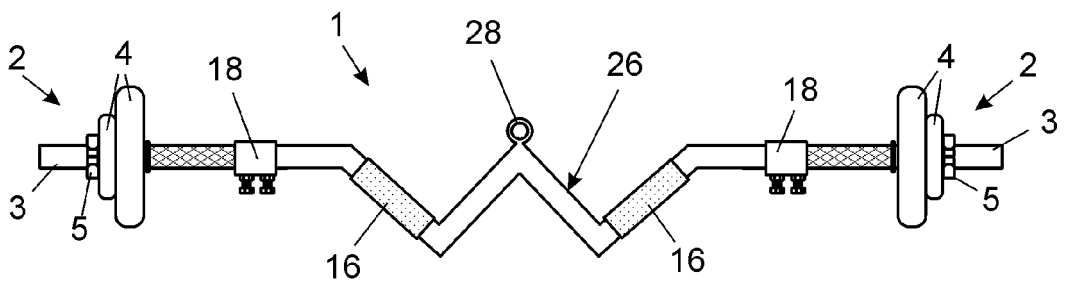

FIG. 24

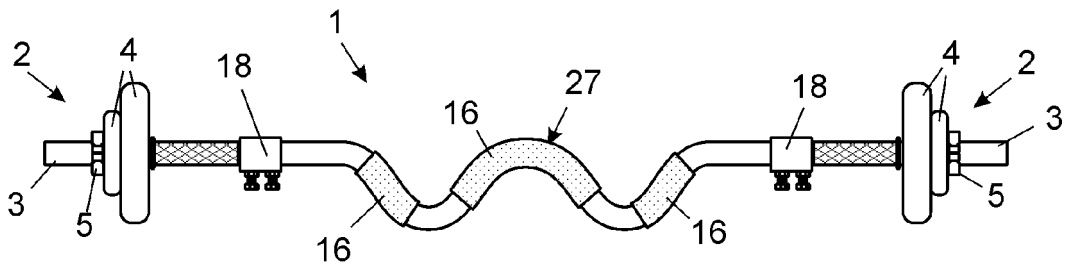

FIG. 25

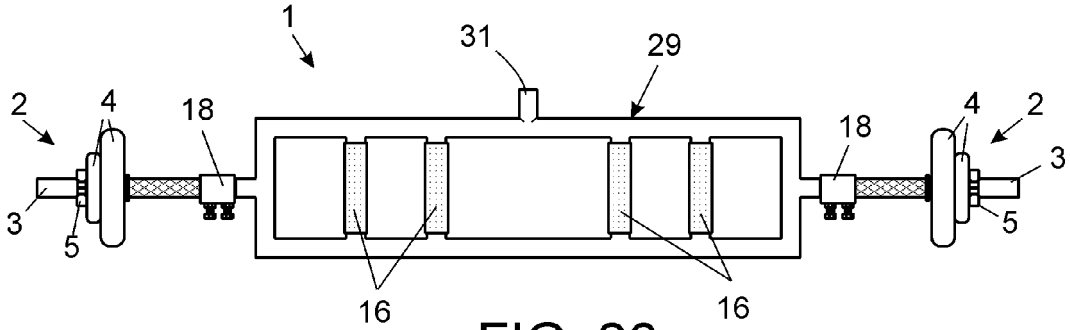

FIG. 26

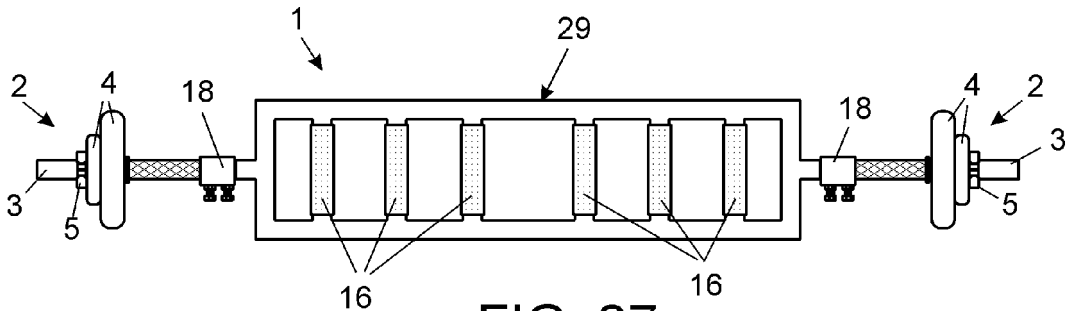

FIG. 27

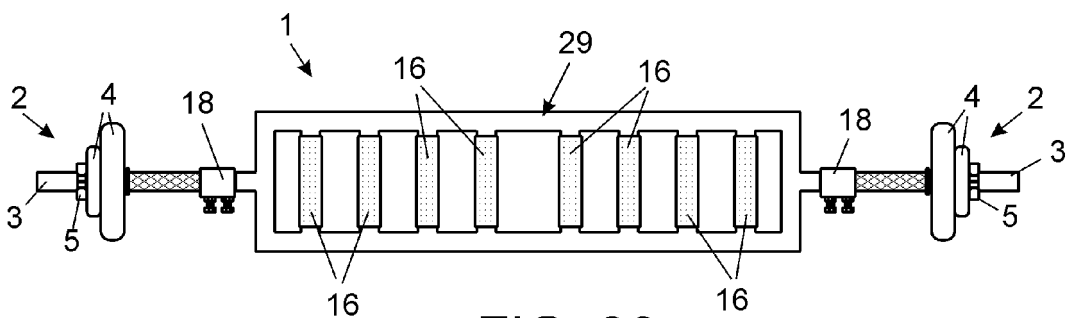

FIG. 28

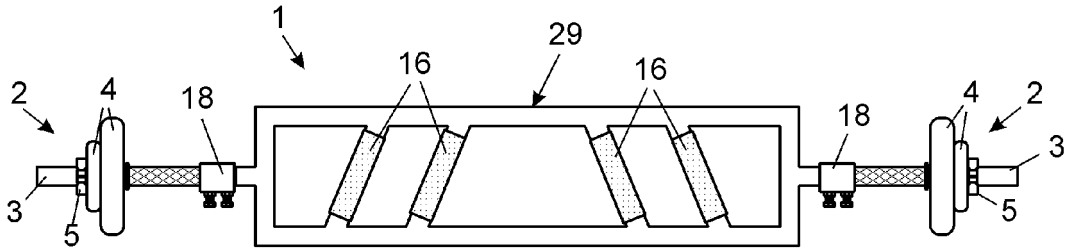

FIG. 29

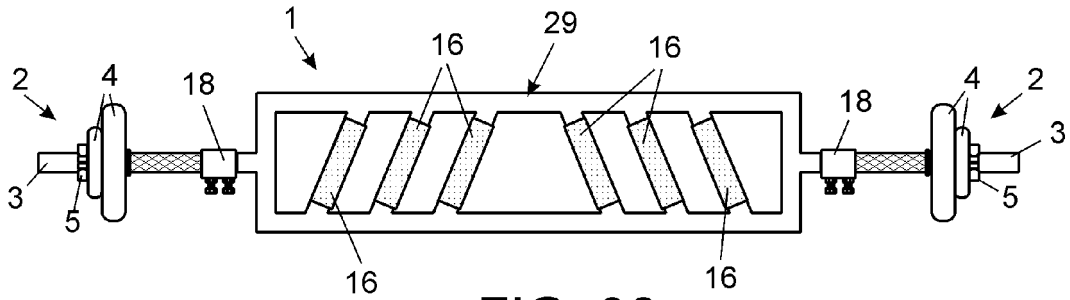

FIG. 30

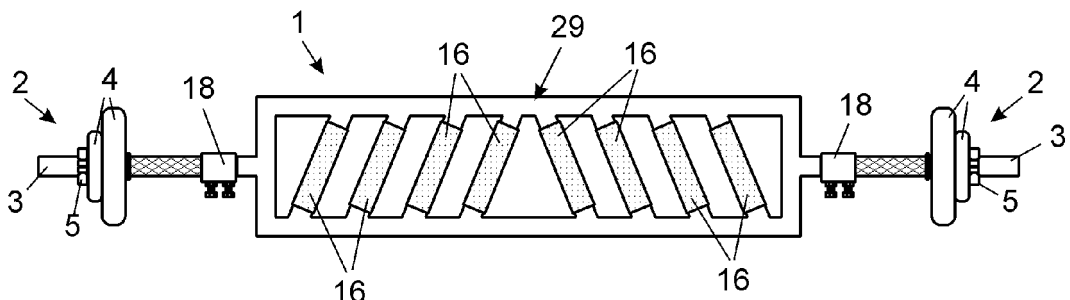

FIG. 31

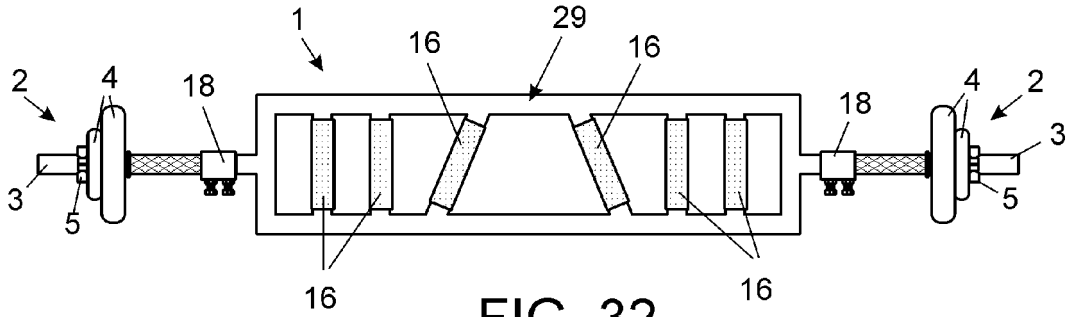

FIG. 32

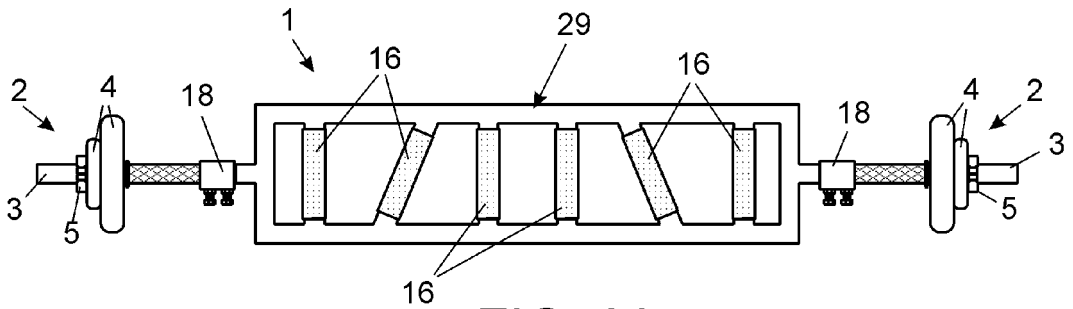

FIG. 33

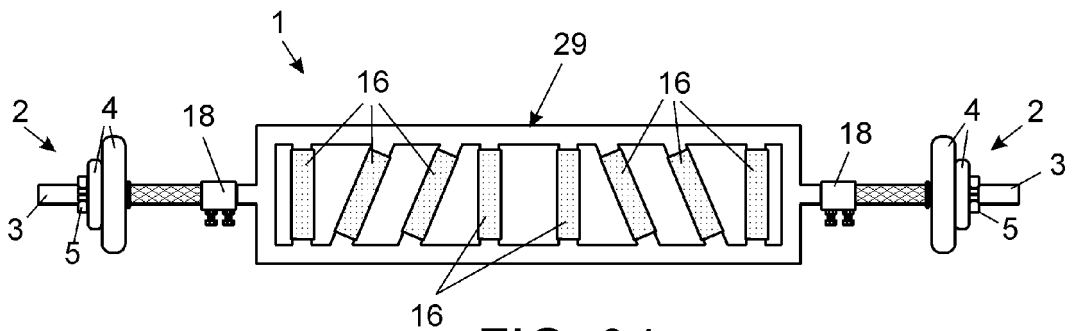

FIG. 34

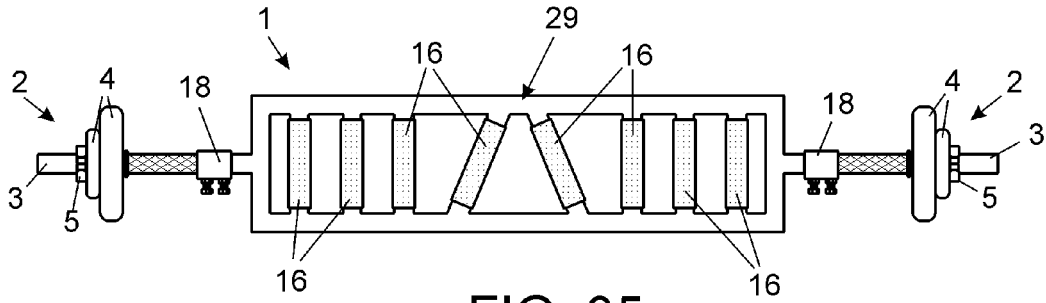

FIG. 35

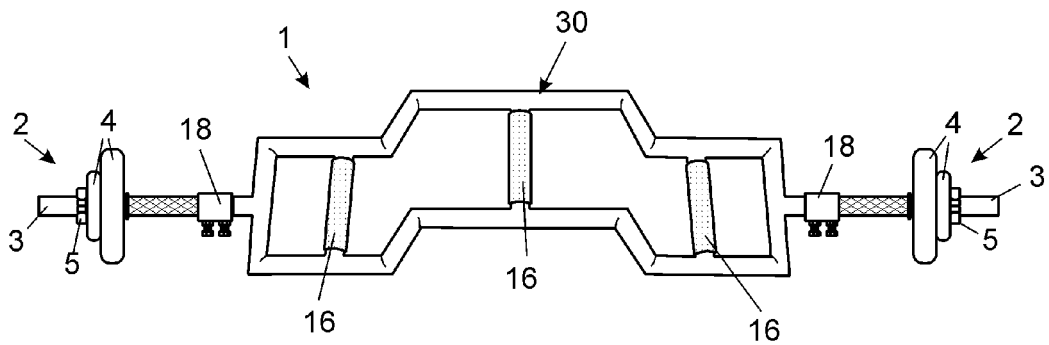

FIG. 36

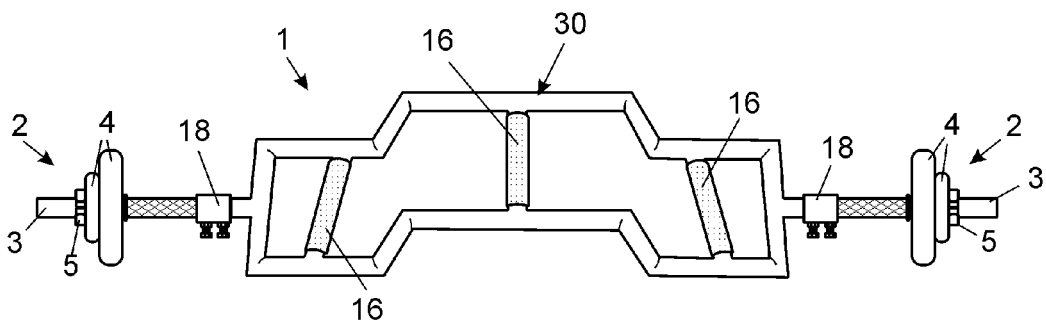

FIG. 37

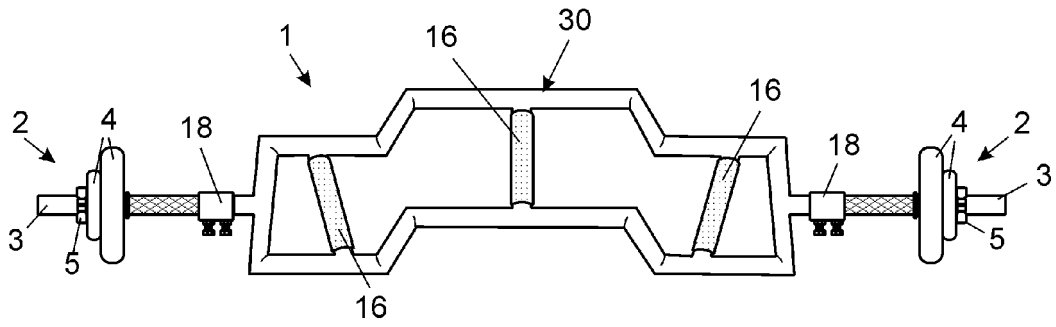

FIG. 38

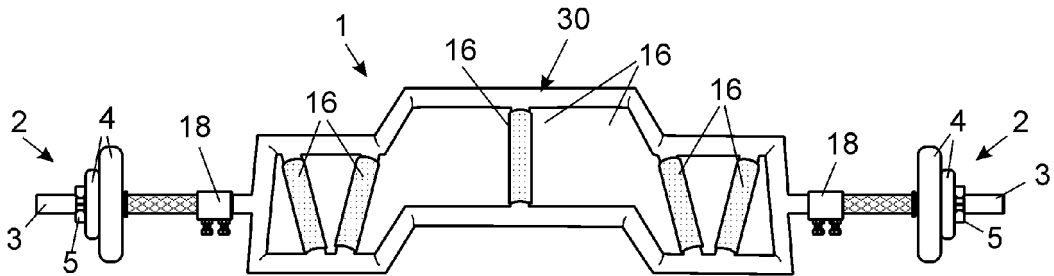

FIG. 39

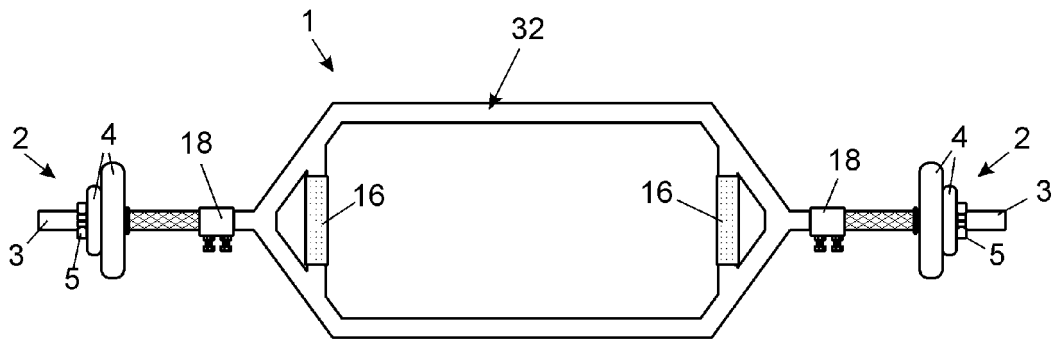

FIG. 40

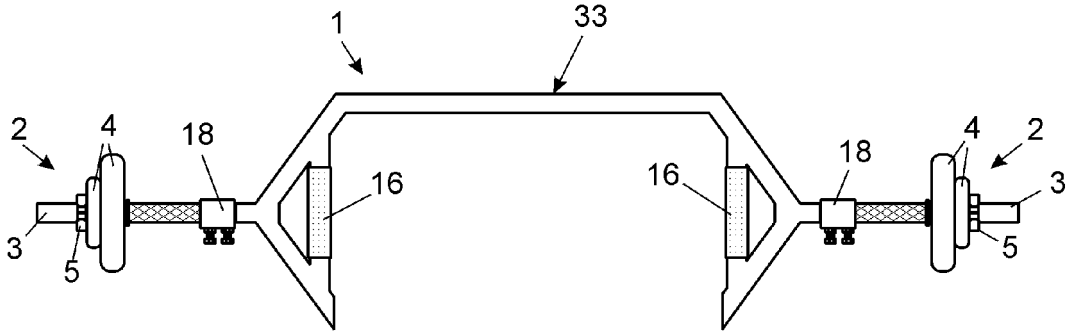

FIG. 41

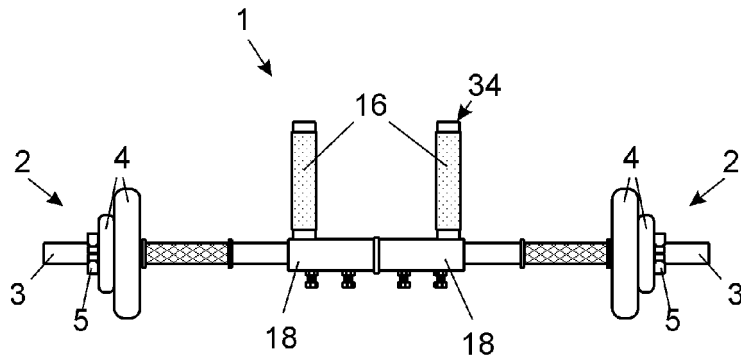

FIG. 42

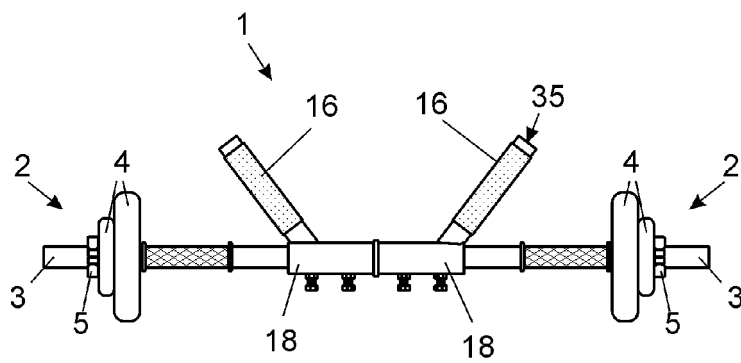

FIG. 43

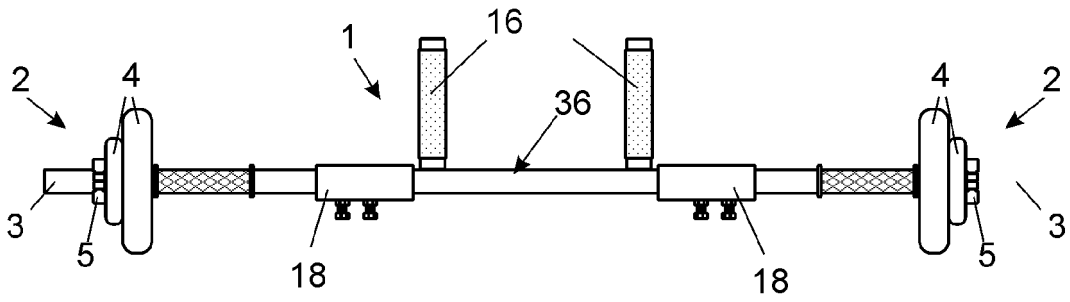

FIG. 44

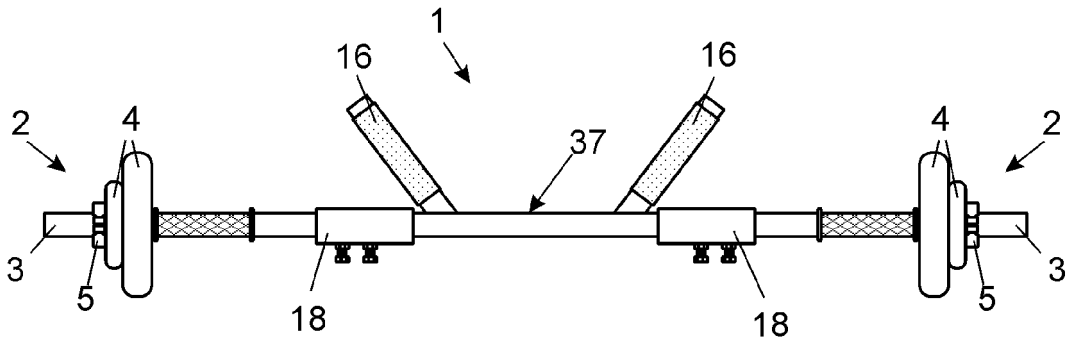

FIG. 45

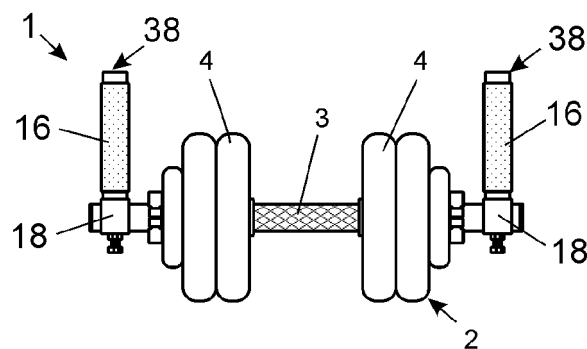

FIG. 46

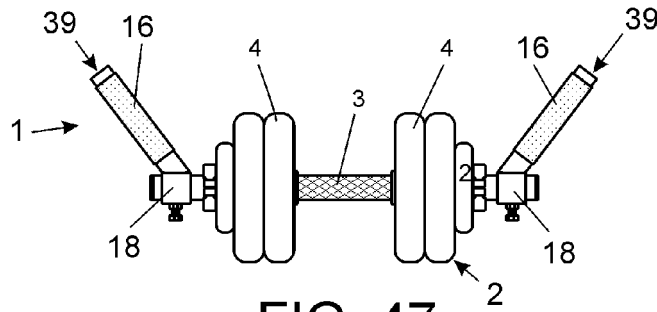

FIG. 47

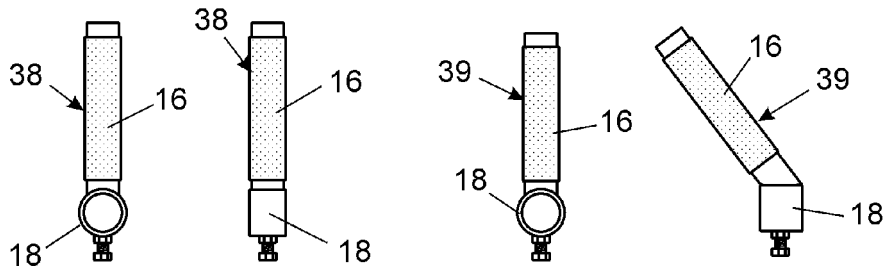

FIG. 48

FIG. 49

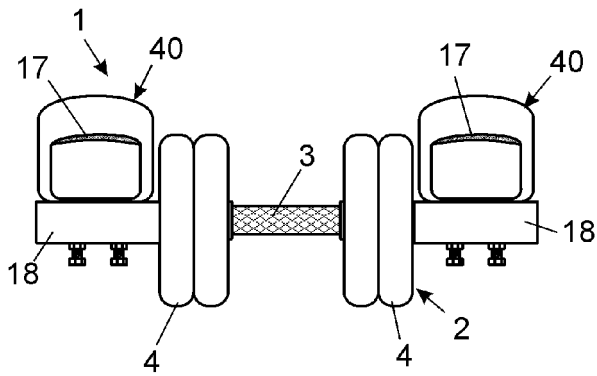

FIG. 50

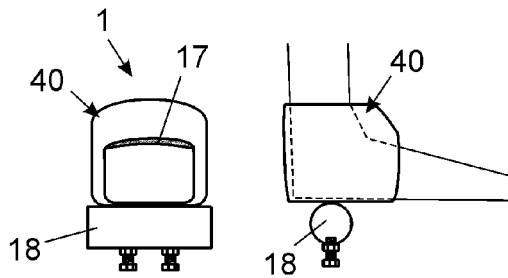

FIG. 51

INTERNATIONAL SEARCH REPORT

International application No.

PCT/ES2022/070310

5	A. CLASSIFICATION OF SUBJECT MATTER	
	A63B21/072 (2006.01)	
	According to International Patent Classification (IPC) or to both national classification and IPC	
10	B. FIELDS SEARCHED	
	Minimum documentation searched (classification system followed by classification symbols) A63B	
	Documentation searched other than minimum documentation to the extent that such documents are included in the fields searched	
15	Electronic data base consulted during the international search (name of data base and, where practicable, search terms used)	
	EPODOC, INVENES, WPI	
	C. DOCUMENTS CONSIDERED TO BE RELEVANT	
20	Category*	Citation of document, with indication, where appropriate, of the relevant passages
		Relevant to claim No.
	X	KR 20100001829U U 19/02/2010, description; figures 1 - 4.
25	Y	KR 20100001829U U 19/02/2010,
	X	US 2003004040 A1 (PARKER LARRY M) 02/01/2003, description; figures 1 - 5.
	Y	US 2003004040 A1 (PARKER LARRY M) 02/01/2003,
30	X	US 2020061407 A1 (LACROCE JOE) 27/02/2020, description; figures 1 - 7.
	X	JP 2000093549 A (AKITA YOSHIO) 04/04/2000, description; figures 1 - 3.
35		
	<input checked="" type="checkbox"/> Further documents are listed in the continuation of Box C. <input checked="" type="checkbox"/> See patent family annex.	
40	* Special categories of cited documents:	"T" later document published after the international filing date or priority date and not in conflict with the application but cited to understand the principle or theory underlying the invention
	"A" document defining the general state of the art which is not considered to be of particular relevance.	
	"E" earlier document but published on or after the international filing date	
45	"L" document which may throw doubts on priority claim(s) or which is cited to establish the publication date of another citation or other special reason (as specified)	"X" document of particular relevance; the claimed invention cannot be considered novel or cannot be considered to involve an inventive step when the document is taken alone
	"O" document referring to an oral disclosure use, exhibition, or other means.	"Y" document of particular relevance; the claimed invention cannot be considered to involve an inventive step when the document is combined with one or more other documents, such combination being obvious to a person skilled in the art
	"P" document published prior to the international filing date but later than the priority date claimed	"&" document member of the same patent family
50	Date of the actual completion of the international search 22/08/2022	Date of mailing of the international search report (25/08/2022)
	Name and mailing address of the ISA/ OFICINA ESPAÑOLA DE PATENTES Y MARCAS Paseo de la Castellana, 75 - 28071 Madrid (España) Facsimile No.: 91 349 53 04	Authorized officer J. Moreno Rodriguez Telephone No. 91 3495556
55	Form PCT/ISA/210 (second sheet) (January 2015)	

INTERNATIONAL SEARCH REPORT

International application No. PCT/ES2022/070310
--

5

C (continuation). DOCUMENTS CONSIDERED TO BE RELEVANT		
Category *	Citation of documents, with indication, where appropriate, of the relevant passages	Relevant to claim No.
X	US 2014024506 A1 (VIXATHEP SIMON) 23/01/2014, description; figures 1 - 5.	1, 4-6,8,15
X	US 2020094101 A1 (LONG MARLON) 26/03/2020, description; figures 1 - 4.	1, 18, 20
X	US 2019308056 A1 (GUBERA EVAN) 10/10/2019, description; figures 1 - 18.	1-19
A	US 2003130096 A1 (LACROCE JOSEPH LAURENCE) 10/07/2003, description; figures 1 - 5.	1-22
A	US 2011177922 A1 (SELINGER JAYME C) 21/07/2011, description; figures 1 - 5.	1-22
A	US 2012252641 A1 (ODNEAL JOSEPH ET AL.) 04/10/2012, description; figures 1 - 10.	1-22

10

15

20

25

30

35

40

45

50

55

INTERNATIONAL SEARCH REPORT

International application No.

PCT/ES2022/070310

Information on patent family members

5
10
15
20
25
30
35
40
45
50
55

Patent document cited in the search report	Publication date	Patent family member(s)	Publication date
KR20100001829U U	19.02.2010	NONE	
-----	-----	-----	-----
US2003004040 A1	02.01.2003	US6592499 B2	15.07.2003
-----	-----	-----	-----
US2020061407 A1	27.02.2020	NONE	
-----	-----	-----	-----
JP2000093549 A	04.04.2000	JP3077683B B2	14.08.2000
-----	-----	-----	-----
US2014024506 A1	23.01.2014	NONE	
-----	-----	-----	-----
US2020094101 A1	26.03.2020	US10843030 B2	24.11.2020
-----	-----	-----	-----
US2019308056 A1	10.10.2019	ES2885244T T3	13.12.2021
		DK3549643T T3	23.08.2021
		AU2019202406 A1	24.10.2019
		AU2019202406 B2	10.09.2020
		CN110339529 A	18.10.2019
		CN110339529 B	25.03.2022
		US10881895 B2	05.01.2021
		EP3549643 A1	09.10.2019
		EP3549643 B1	19.05.2021
-----	-----	-----	-----
US2003130096 A1	10.07.2003	NONE	
-----	-----	-----	-----
US2011177922 A1	21.07.2011	NONE	
-----	-----	-----	-----
US2012252641 A1	04.10.2012	US2015105224 A1	16.04.2015
-----	-----	-----	-----