



(11)

EP 4 368 089 A1

(12)

EUROPEAN PATENT APPLICATION
published in accordance with Art. 153(4) EPC

(43) Date of publication:

15.05.2024 Bulletin 2024/20

(51) International Patent Classification (IPC):

A47L 11/24^(2006.01) A47L 11/40^(2006.01)

(21) Application number: **22836539.1**

(52) Cooperative Patent Classification (CPC):

A47L 11/24; A47L 11/40

(22) Date of filing: **24.03.2022**

(86) International application number:

PCT/CN2022/082846

(87) International publication number:

WO 2023/279780 (12.01.2023 Gazette 2023/02)

(84) Designated Contracting States:

**AL AT BE BG CH CY CZ DE DK EE ES FI FR GB
GR HR HU IE IS IT LI LT LU LV MC MK MT NL NO
PL PT RO RS SE SI SK SM TR**

Designated Extension States:

BA ME

Designated Validation States:

KH MA MD TN

(71) Applicant: **Beijing Roborock Technology Co., Ltd.
Beijing 102206 (CN)**

(72) Inventor: **YU, Guang
Beijing 102206 (CN)**

(74) Representative: **Studio Torta S.p.A.
Via Viotti, 9
10121 Torino (IT)**

(30) Priority: **05.07.2021 CN 202121515792 U**

(54) **DUST BOX AND AUTOMATIC CLEANING APPARATUS**

(57) A dust box (100) and an automatic cleaning apparatus. The dust box (100) comprises: a dust box body (10) comprising a bottom wall (15) and at least one side wall arranged surrounding the edge of the bottom wall (15), wherein the side wall extends from the bottom wall (15) and moves away from the bottom wall (15), and an accommodation space (30) is enclosed by the bottom wall (15) and the side wall; and a dust box cover (20) pivotally connected to a first side wall (11) of the dust box body (10) and configured to seal the top of the accommodation space (30), wherein a second side wall (12) of the dust box (100) is provided with a spring sheet assembly (40) elastically and pivotally connected to the second side wall (12); the spring sheet assembly (40) is rotatable, relative to the second side wall (12), around a first axis (A1) extending in a first direction (X), the first direction (X) being parallel to the bottom wall (15); and the dust box cover (20) has a protrusion (21), which is configured to match the spring sheet assembly (40) as the dust box cover (20) seals the top of the accommodation space (30), thereby preventing the omission of mounting a filter screen assembly after cleaning the dust box (100).

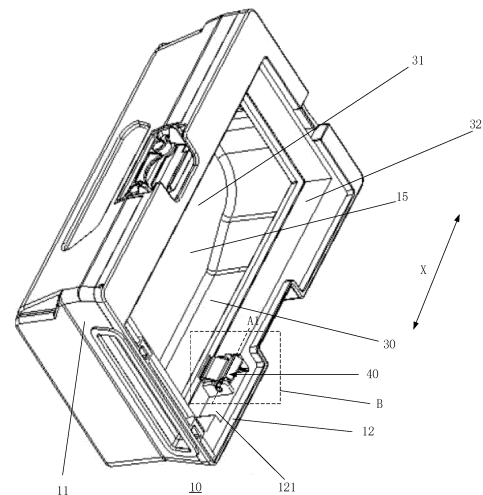

FIG. 3

EP 4 368 089 A1

Description

CROSS-REFERENCE TO RELATED APPLICATION

[0001] This application claims priority of the Chinese Patent Application No. 202121515792.8 filed on July 5, 2021, which is incorporated herein by reference in its entirety as a part of this application.

TECHNICAL FIELD

[0002] The present disclosure relates to the technical field of automatic cleaning apparatuses, and particularly to a dust box and an automatic cleaning apparatus.

BACKGROUND ART

[0003] With the continuous development of science and technology, automatic cleaning apparatuses, such as robot vacuum cleaners, have been widely used by households, and the robot vacuum cleaners are more time-saving and labor-saving than traditional manual cleaning.

[0004] It is to be noted that the information disclosed in the Background Art section merely serves to enhance the understanding of the background of the present disclosure, and thus may include information that does not constitute prior art known to those of ordinary skill in the art.

SUMMARY OF THE INVENTION

[0005] Some embodiments of the present disclosure provide a dust box. The dust box includes: a dust box body including a bottom wall and at least one side wall disposed around an edge of the bottom wall, where the side wall extends away from the bottom wall from the bottom wall, and the bottom wall and the side wall enclose an accommodation space; and a dust box lid, pivotally connected to a first side wall of the dust box body and configured to cover a top of the accommodation space; where a second side wall of the dust box has an elastic sheet assembly pivotally and elastically connected to the second side wall, and the elastic sheet assembly is rotatable relative to the second side wall about a first axis extending in a first direction, the first direction being parallel to the bottom wall; and where the dust box lid has a protruding portion configured to cooperate with the elastic sheet assembly in a process in which the dust box lid covers the top of the accommodation space.

[0006] In some embodiments, the elastic sheet assembly includes: a rotating member, which is rotatable relative to the second side wall about the first axis between a first position and a second position; and an elastic member, which causes the rotating member to be biased at the first position.

[0007] In some embodiments, the rotating member includes a first portion and a second portion, a common

boundary between the first portion and the second portion is parallel to the first axis, and the first portion and the second portion form a predetermined angle.

[0008] In some embodiments, in response to the rotating member being located at the first position, a first end of the first portion away from the bottom wall presses against the second side wall; and in response to the rotating member being located at the second position, a gap is formed between the first end of the first portion and the second side wall; and the gap is configured to accommodate the protruding portion, such that the dust box lid completely covers the top of the accommodation space.

[0009] In some embodiments, the dust box further includes a filter screen assembly configured to be removably disposed in the accommodation space, where a first raised portion is provided on a first side of the filter screen assembly, and the first raised portion is configured to cooperate with the elastic sheet assembly in a process in which the filter screen assembly is placed in the accommodation space.

[0010] In some embodiments, the second portion is pressed by the first raised portion in the process in which the filter screen assembly is placed in the accommodation space, such that the rotating member rotates from the first position to the second position.

[0011] In some embodiments, a second raised portion is provided on a second side of the filter screen assembly, where the first side is provided opposite the second side, and the first raised portion is centre-symmetrical to the second raised portion with respect to a center of the filter screen assembly.

[0012] In some embodiments, the second side wall is provided with a recess, and the elastic sheet assembly is provided within the recess.

[0013] In some embodiments, the second side wall abuts against the first side wall, and the elastic sheet assembly is provided at a portion of the second side wall close to the first side wall.

[0014] Some embodiments of the present disclosure provide an automatic cleaning apparatus including the dust box according to the preceding embodiments.

[0015] Compared with the related art, the above solutions according to the embodiments of the present disclosure may have at least the following beneficial effect: the missed assembling of the filter screen assembly after the dust box has been cleaned is avoided.

BRIEF DESCRIPTION OF THE DRAWINGS

[0016] The accompanying drawings herein, incorporated in and constitute a part of the description, show the embodiments conforming to the present disclosure and are used together with the description to explain the principles of the present disclosure. Apparently, the accompanying drawings in the following description show merely some embodiments of the present disclosure, and a person of ordinary skill in the art may still derive other

accompanying drawings from these accompanying drawings without creative efforts. In the accompanying drawings:

FIG. 1 is a schematic structural diagram of a dust box according to some embodiments of the present disclosure;

FIG. 2 is a schematic structural diagram of a dust box lid of the dust box in FIG. 1;

FIG. 3 is a schematic structural diagram of a dust box body of the dust box in FIG. 1;

FIG. 4 is a partially enlarged schematic diagram of FIG. 3;

FIG. 5 is a schematic structural diagram of a filter screen assembly according to some embodiments of the present disclosure;

FIG. 6 is a schematic structural diagram after a filter screen assembly is placed into a dust box body according to some embodiments of the present disclosure; and

FIG. 7 is a schematic structural diagram of an automatic cleaning apparatus according to some embodiments of the present disclosure.

DETAILED DESCRIPTION

[0017] To make the objectives, technical solutions and advantages of the present disclosure clearer, the present disclosure will be further described in detail below with reference to the accompanying drawings. It is obvious that the described embodiments are only some, but not all of the embodiments of the present disclosure. All other embodiments obtained by those of ordinary skills in the art without creative efforts based on the embodiments in the present disclosure are within the protection scope of the present disclosure.

[0018] It is also to be noted that, the terms "comprise", "include", or any other variants are intended to cover the nonexclusive inclusion, such that a commodity or device including a series of elements includes not only those elements, but also other elements not listed explicitly or elements inherent to such a commodity or device. Without more limitations, the element defined by the phrase "comprising a ..." does not exclude the existence of other same elements in the commodity or device including an element.

[0019] An automatic cleaning apparatus typically includes a dust box for collecting garbage; and when the automatic cleaning apparatus performs a cleaning operation, the garbage, such as dust and paper scraps, in an operation area is collected in the dust box. When a great deal of garbage is collected in the dust box, a user can remove the dust box from the automatic cleaning apparatus and open the dust box to remove the garbage. When the garbage is removed from the dust box, it is usually necessary to remove the filter screen assembly from the dust box in order to remove the garbage.

[0020] The present disclosure provides a dust box,

such as a dust box of an automatic cleaning apparatus, such as a robot vacuum cleaner. The dust box includes: a dust box body including a bottom wall and at least one side wall disposed around an edge of the bottom wall, where the side wall extends away from the bottom wall from the bottom wall, and the bottom wall and the side wall enclose an accommodation space; and a dust box lid, pivotally connected to a first side wall of the dust box body and configured to cover a top of the accommodation space. A second side wall of the dust box has an elastic sheet assembly pivotally and elastically connected to the second side wall, and the elastic sheet assembly is rotatable relative to the second side wall about a first axis extending in a first direction, the first direction being parallel to the bottom wall. The dust box has a protruding portion configured to cooperate with the elastic sheet assembly in the process in which the dust box lid covers the top of the accommodation space.

[0021] With this type of dust box, missed assembling of the filter screen assembly can be avoided when the dust box is installed back into the automatic cleaning apparatus after the garbage is removed from the dust box. Specifically, with the dust box according to the present disclosure, the dust box lid can cover the top of the accommodation space and be snapped onto the dust box body only after the user has installed the filter screen assembly into the accommodation structure within the dust box body. When the user does not install the filter screen assembly, the dust box lid cannot be snapped onto the dust box body, thereby reminding the user so as to avoid the missed assembling of the filter screen assembly.

[0022] Alternative embodiments of the present disclosure are described in detail below with reference to the accompanying drawings.

[0023] FIG. 1 is a schematic structural diagram of a dust box according to some embodiments of the present disclosure; FIG. 2 is a schematic structural diagram of a dust box lid of the dust box in FIG. 1; and FIG. 3 is a schematic structural diagram of a dust box body of the dust box in FIG. 1. As shown in FIGs. 1-3, the dust box 100 includes a dust box body 10 and a dust box lid 20. The dust box body 10 includes a bottom wall 15 and at least one side wall disposed around the edge of the bottom wall 10. The side wall extends away from the bottom wall 15 from the bottom wall 15, and the bottom wall 15 and the side wall enclose an accommodation space 30 configured to accommodate garbage and a filter screen assembly.

[0024] The dust box lid 20 is pivotally connected to a first side wall 11 of the dust box body 10 and is configured to cover the top of the accommodation space 30. The dust box body 10 is roughly cuboidal, and an orthographic projection of the dust box body 10 on a plane where the bottom wall 15 is located is substantially rectangular. The first side wall 11 of the dust box body 10 is, for example, a short-side wall of the dust box body 10. The short-side wall herein refers to a side wall of the cuboid correspond-

ing to a short side of the rectangular projection, and correspondingly, a long-side wall herein refers to a side wall of the cuboid corresponding to a long side of the rectangular projection. The dust box lid 20 is rotatable about a pivot axis with respect to the first side wall 11 of the dust box body 10, such that the dust box 100 can be switched between an open state and a closed state.

[0025] The dust box 100 is in the closed state when the dust box lid 20 completely covers the top of the accommodation space and is clamped with the dust box body 10 by a snap-fit structure. The dust box 100 is in the open state when the dust box lid 20 is rotated to enable at least a portion of the accommodation space 30 to be exposed. The dust box 100 can be switched between the closed state and the open state, so that it is convenient for the user to carry out operations, such as clearing the garbage in the dust box 100, cleaning or replacing a filter screen structure.

[0026] A second side wall 12 of the dust box 10 has an elastic sheet assembly 40 pivotally and elastically connected to the second side wall 12, and the elastic sheet assembly 40 is rotatable relative to the second side wall 12 about a first axis A1 extending in a first direction X. The first direction X is parallel to the bottom wall 15, and the first direction X is also parallel to the extending direction of the second side wall 12.

[0027] The dust box lid 20 has a protruding portion 21 configured to cooperate with the elastic sheet assembly 40 in a process in which the dust box lid 20 covers the top of the accommodation space 30. The protruding portion 21 is located on a side surface of the dust box lid 20 facing the dust box body 10 when the dust box lid 20 is snapped onto the dust box body 10, and extends away from the dust box lid 20 from the body of the dust box lid 20.

[0028] With this type of dust box, missed assembling of the filter screen assembly can be avoided when the dust box is installed back into the automatic cleaning apparatus after the garbage is removed from the dust box. Specifically, with the dust box according to the present disclosure, the dust box lid can cover the top of the accommodation space and be snapped onto the dust box body only after the user has installed the filter screen assembly into the accommodation structure within the dust box body. When the user does not install the filter screen assembly, the elastic sheet assembly abuts against the protruding portion of the dust box lid during snapping the dust box lid, such that the dust box lid cannot be snapped onto the dust box body, thereby reminding the user so as to avoid the missed assembling of the filter screen assembly.

[0029] FIG. 4 is a partially enlarged schematic diagram of FIG. 3. Specifically, FIG. 4 is an enlarged schematic diagram of a region B in FIG. 3. As shown in FIGs. 1-4, the elastic sheet assembly 40 includes a rotating member 41 and an elastic member 42. The rotating member 41 is rotatable relative to the second side wall 12 about the first axis A1 between a first position and a second posi-

tion, and the elastic member 42 enables the rotating member 41 to be biased at the first position. The rotating member 41 includes a first portion 411 and a second portion 412, a common boundary between the first portion 411 and the second portion 412 is parallel to the first axis A1, and the first portion 411 and the second portion 412 form a predetermined angle. The cross-section of the rotating member 41 perpendicular to the first axis A1 is, for example, approximately "L" shaped.

[0030] In response to the rotating member 41 being located at the first position, the first end 4111 of the first portion 411 away from the bottom wall 15 presses against the second side wall 12, and specifically presses against the inner wall of the second side wall 12. At this point, in the process in which the dust box lid 20 is snapped towards the dust box body 10, the protruding portion 21 of the dust box lid 20 may press against the first end 4111 of the first portion 411, such that the dust box lid 20 cannot be snapped onto the dust box body 10, thereby reminding the user so as to avoid the missed assembling of the filter screen assembly. In response to the rotating member 41 being located at the second position, a gap G is formed between the first end 4111 of the first portion 411 and the second side wall 12. The gap G is configured to accommodate the protruding portion 21, such that the dust box lid 20 completely covers the top of the accommodation space 30 and at this point the dust box lid 20 can be completely snapped onto the dust box body 10.

[0031] FIG. 5 is a schematic structural diagram of a filter screen assembly according to some embodiments of the present disclosure, and FIG. 6 is a schematic structural diagram when the filter screen assembly is placed into a dust box body according to some embodiments of the present disclosure. As shown in FIGs. 1-6, the dust box 100 further includes a filter screen assembly 50 that is configured to be removably disposed within the accommodation space 30. The filter screen assembly 50 is, for example, shaped like a substantially rectangular plate. A step structure is provided on an inner wall of a side wall of the dust box body 10 and configured to support the filter screen assembly 50. The accommodation space 30 is divided into a first accommodation space 31 and a second accommodation space 32. The first accommodation space 31 is disposed on a side of the second accommodation space 32 away from the bottom wall 15 and is configured to accommodate the filter screen assembly 50, and the second accommodation space 32 is configured to accommodate garbage collected by the dust box 100.

[0032] As shown in FIG. 5 and FIG. 6, a first raised portion is provided on a first side 51 of the filter screen assembly 50, and the first raised portion 511 is configured to cooperate with the elastic sheet assembly 40 in the process in which the filter screen assembly 50 is placed in the first accommodation space 31. Specifically, in the process in which the filter screen assembly 50 is placed in the first accommodation space 31, the second portion 412 of the rotating member 41 is pressed by the first

raised portion 511, which causes the rotating member 41 to rotate from the first position to the second position. The rotating member 41 is at the second position when the filter screen assembly 50 is fully placed in the first accommodation space 31. At this point, the gap G exists between the first end 4111 of the first portion 411 of the rotating member 41 and the second side wall 12. In the process in which the dust box lid 20 is snapped onto the dust box body 10, the protruding portion 21 of the dust box lid 20 can be accommodated in the gap G, such that the dust box lid 20 can be fully snapped onto the dust box body 10.

[0033] In a case where the filter screen assembly 50 is missed, for example, after the user opens the dust box 100, dismounts the filter screen assembly 50 and removes the garbage inside the dust box 100, he/her forgets to install the filter screen assembly 50 back into the first accommodation space 31, at this point, due to the elastic biasing effect of the elastic member 42, the rotating member 41 is located at the first position. That is, the first end 4111 of the first portion 411 of the rotating member 41 away from the bottom wall 15 presses against the second side wall 12. At this point, in the process in which the dust box lid 20 is snapped onto the dust box body 10, the protruding portion 21 of the dust box lid 20 may press against the first end 4111 of the first portion 411, such that the dust box lid 20 cannot be snapped onto the dust box body 10, thereby reminding the user so as to avoid the missed assembling of the filter screen assembly.

[0034] In some embodiments, a handle structure 55 is provided at a middle position of a surface, such as the top surface, of the filter screen assembly 50, so that it is convenient for the user to hold the filter screen assembly 50 to perform operations of removing the filter screen assembly 50 from the dust box 100 or installing the filter screen assembly back into the dust box 100.

[0035] In some embodiments, the filter screen assembly 50 is of a centro-symmetric structure, and a second raised portion 521 is provided on the second side 52 of the filter screen assembly 50. The first side 51 is provided opposite the second side 52, and the first raised portion 511 is centro-symmetrical to the second raised portion 521 with respect to the center of the filter screen assembly 50.

[0036] With the filter screen assembly 50 so designed, the user does not have to pay too much attention to the installation alignment of the filter screen assembly when installing the filter screen assembly 50 back into the dust box 100. As long as the filter screen assembly 50 is installed back into the first accommodation space 31, one of the first raised portion 511 and the second raised portion 521 may press the second portion 412 of the rotating member 41, such that the rotating member 41 is at the second position and the dust box lid 20 can be fully snapped onto the dust box body 10.

[0037] In some embodiments, as described in FIG. 3, the second side wall 12 is provided with a recess 121,

and the elastic sheet assembly 40 is provided within the recess 121. With such a configuration, the overall structure of the dust box is relatively compact, which avoids the excessive extension of the elastic sheet assembly 40 from the second side wall 12 into the accommodation space 30, ensures the substantially rectangular plate-like structure of the filter screen assembly 50, and facilitates the manufacturing of the filter screen assembly.

[0038] In some embodiments, as shown in FIG. 1 to FIG. 3, the second side wall 12 abuts against the first side wall 11, and the elastic sheet assembly 40 is provided at a portion of the second side wall 12 close to the first side wall 11. However, the present disclosure is not limited thereto, and the elastic sheet assembly 40 may also be provided at a portion of the second side wall 12 away from the first side wall 11.

[0039] In other embodiments, the elastic sheet assembly 40 may also be disposed on a side wall opposite the first side wall 11, which is not specifically limited in the present disclosure as long as the dust box lid 20 and the elastic sheet assembly 40 correspond to each other in position, and cooperate with each other in the process in which the dust box lid covers the top of the accommodation space.

[0040] FIG. 7 is a schematic structural diagram of an automatic cleaning apparatus according to some embodiments of the present disclosure. As shown in FIG. 7, the automatic cleaning apparatus 200, such as a robot vacuum cleaner, includes a steering wheel and driving wheels. Under the action of the steering wheel and the driving wheels, the automatic cleaning apparatus 200 can be moved on a support surface, such as ground, to perform the cleaning operation. The automatic cleaning apparatus 200 includes a dust box 100 in the preceding embodiment for accommodating the garbage collected by the automatic cleaning apparatus 200 during the cleaning operation.

[0041] Finally, it should be noted that various embodiments in the Description are described in a progressive manner, each embodiment focuses on the differences from other embodiments, and the same or similar parts among the various embodiments may refer to one another. Since the system or device disclosed in the embodiment corresponds to the method disclosed in the embodiment, the description is relatively simple, and the relevant parts may refer to the description of the method part.

[0042] The above embodiments are only used to illustrate the technical solutions of the present disclosure and are not intended to limit the present disclosure. Although the present disclosure has been described in detail with reference to the foregoing embodiments, those of ordinary skills in the art should understand that, they can still make modifications to the technical solutions described in the foregoing embodiments or make equivalent substitutions to some of the technical features; and these modifications or substitutions do not make the essence of the corresponding technical solutions deviate from the

spirit and scope of the technical solutions of the various embodiments of the present disclosure.

Claims

1. A dust box, comprising:

a dust box body, comprising a bottom wall and at least one side wall disposed around an edge of the bottom wall, wherein the side wall extends away from the bottom wall from the bottom wall, and the bottom wall and the side wall enclose an accommodation space; and

a dust box lid, pivotally connected to a first side wall of the dust box body and configured to cover a top of the accommodation space, wherein a second side wall of the dust box has an elastic sheet assembly pivotally and elastically connected to the second side wall, and the elastic sheet assembly is rotatable relative to the second side wall about a first axis extending in a first direction, the first direction being parallel to the bottom wall; and

the dust box lid has a protruding portion configured to cooperate with the elastic sheet assembly in a process in which the dust box lid covers the top of the accommodation space.

2. The dust box according to claim 1, wherein the elastic sheet assembly comprises:

a rotating member, which is rotatable relative to the second side wall about the first axis between a first position and a second position; and
an elastic member, which causes the rotating member to be biased at the first position.

3. The dust box according to claim 2, wherein the rotating member comprises a first portion and a second portion, a common boundary between the first portion and the second portion is parallel to the first axis, and the first portion and the second portion form a predetermined angle.

4. The dust box according to claim 3, wherein in response to the rotating member being located at the first position, a first end of the first portion away from the bottom wall presses against the second side wall; and in response to the rotating member being located at the second position, a gap is formed between the first end of the first portion and the second side wall; and the gap is configured to accommodate the protruding portion, such that the dust box lid completely covers the top of the accommodation space.

5. The dust box according to claim 3, further comprising:

a filter screen assembly configured to be removably disposed in the accommodation space, wherein a first raised portion is provided on a first side of the filter screen assembly, and the first raised portion is configured to cooperate with the elastic sheet assembly in a process in which the filter screen assembly is placed in the accommodation space.

6. The dust box according to claim 5, wherein the second portion is pressed by the first raised portion in the process in which the filter screen assembly is placed in the accommodation space, such that the rotating member rotates from the first position to the second position.

7. The dust box according to claim 5, wherein a second raised portion is provided on a second side of the filter screen assembly, the first side is provided opposite the second side, and the first raised portion is centro-symmetrical to the second raised portion with respect to a center of the filter screen assembly.

8. The dust box according to claim 1, wherein the second side wall is provided with a recess, and the elastic sheet assembly is provided within the recess.

9. The dust box according to claim 1, wherein the second side wall abuts against the first side wall, and the elastic sheet assembly is provided at a portion of the second side wall close to the first side wall.

10. An automatic cleaning apparatus, comprising the dust box according to any one of claims 1 to 9.

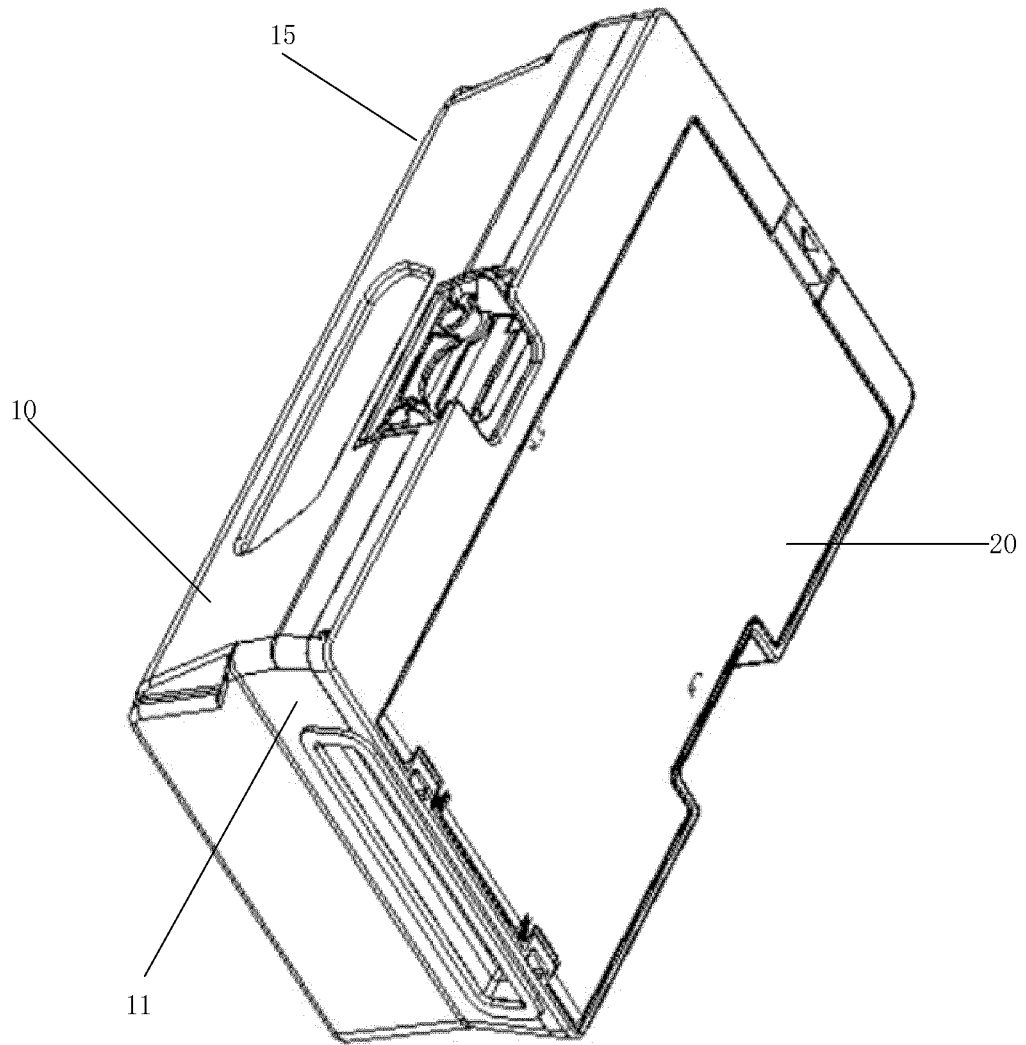

100

FIG. 1

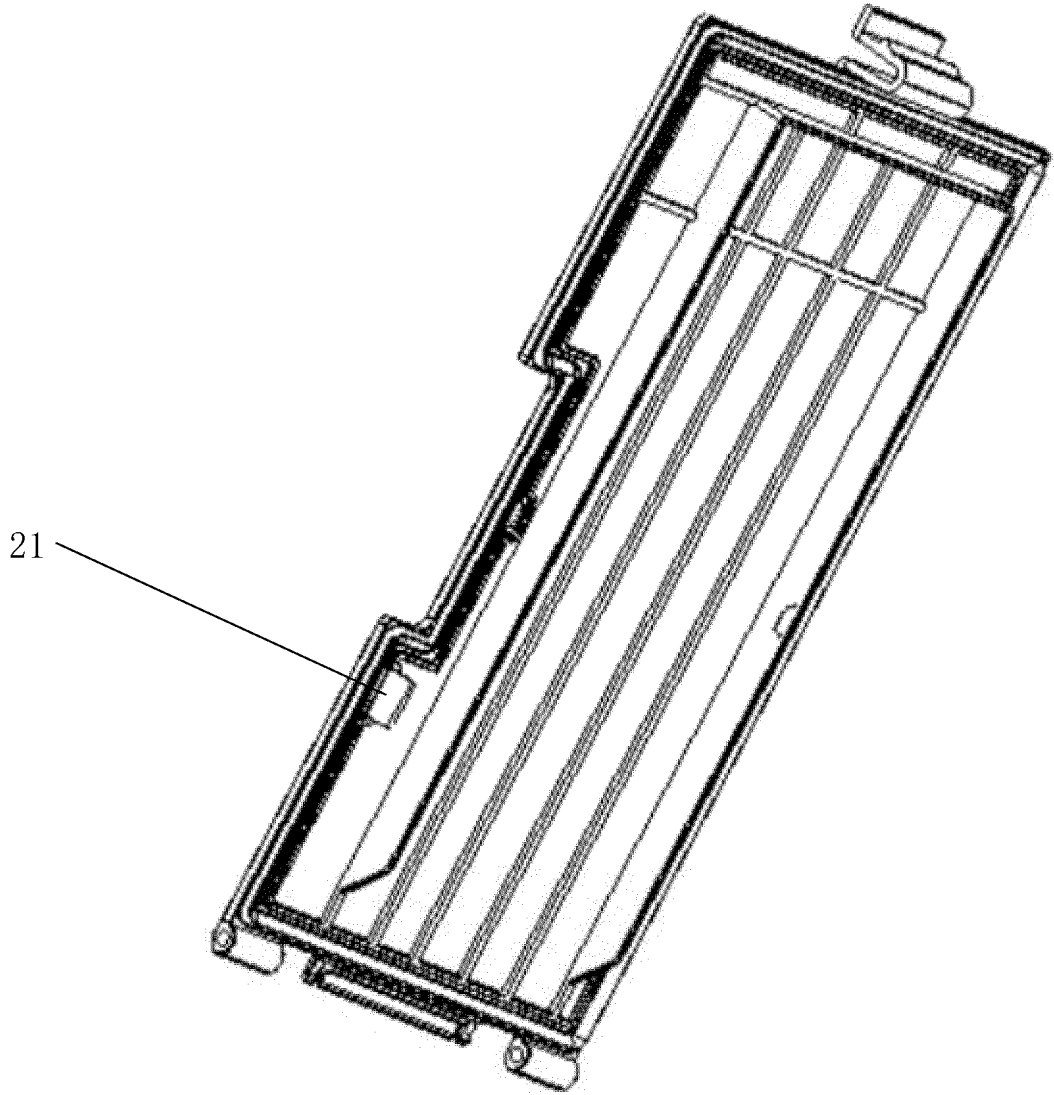

20

FIG. 2

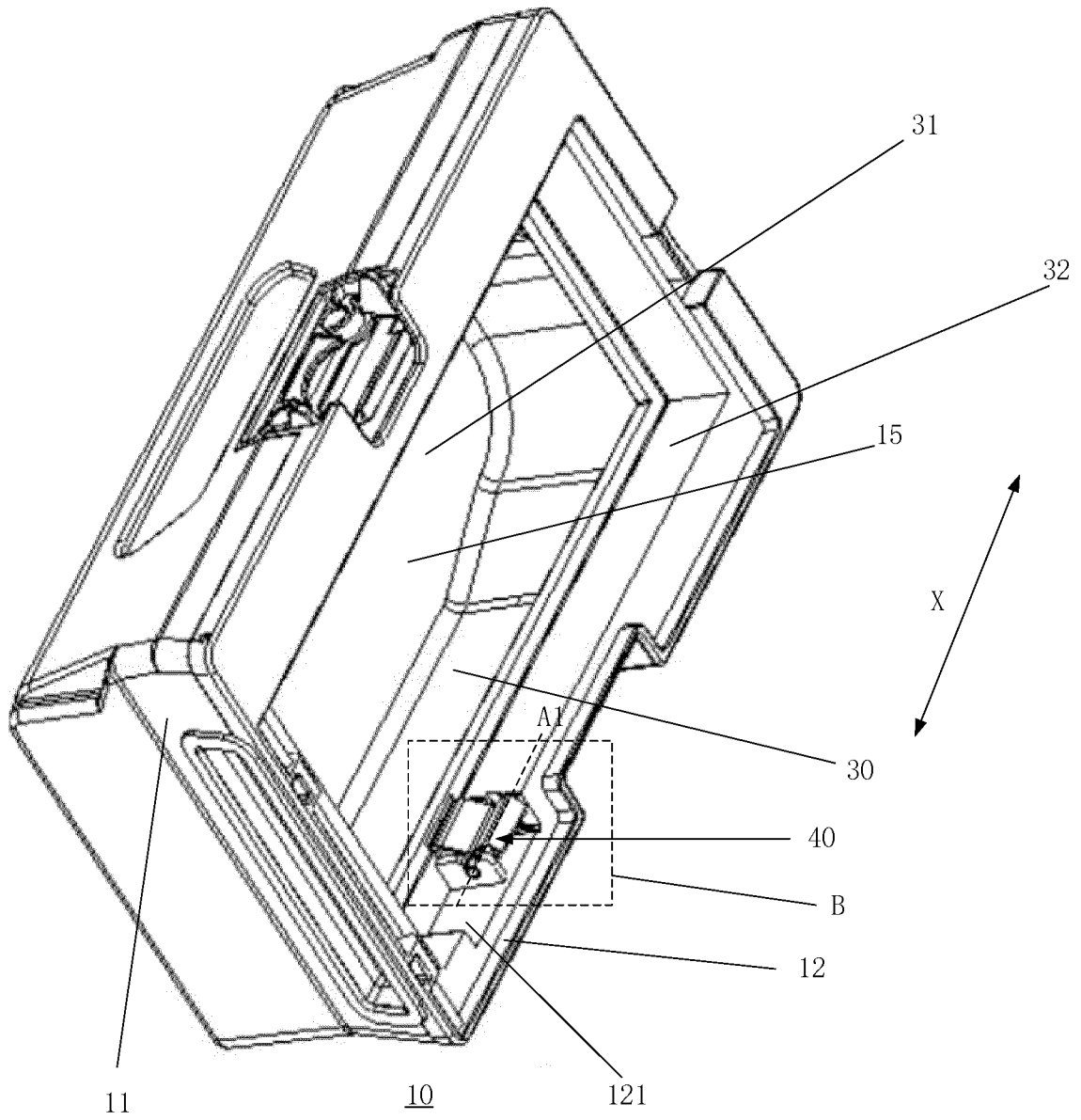

FIG. 3

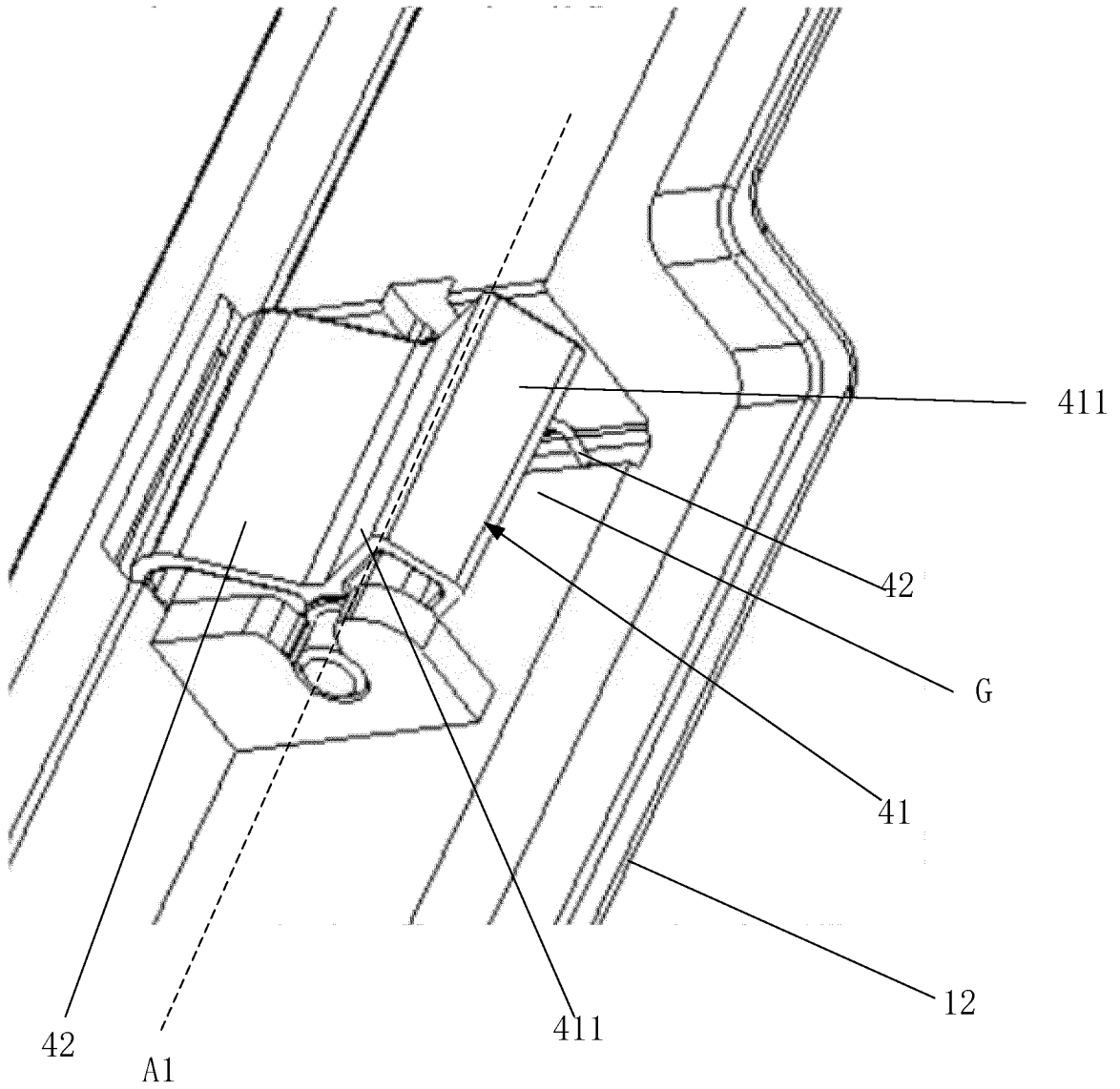

FIG. 4

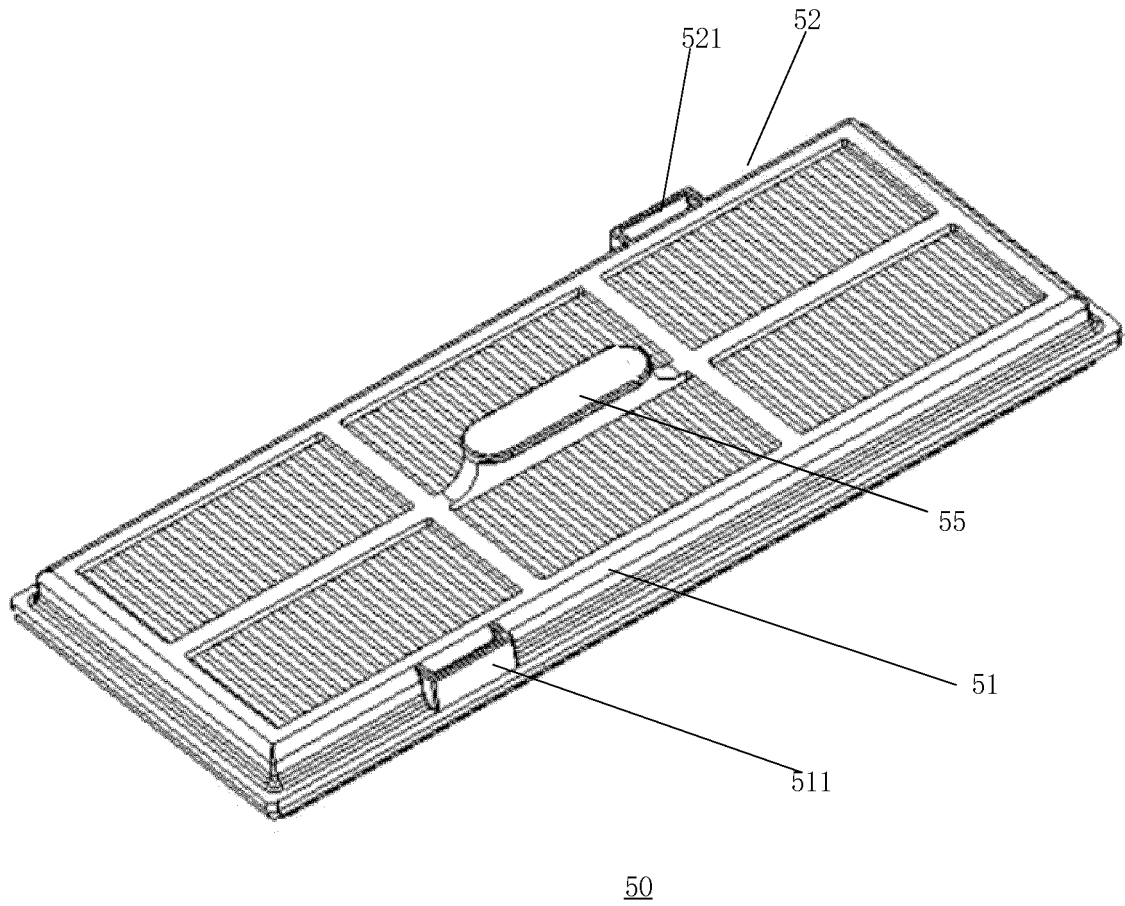

FIG.5

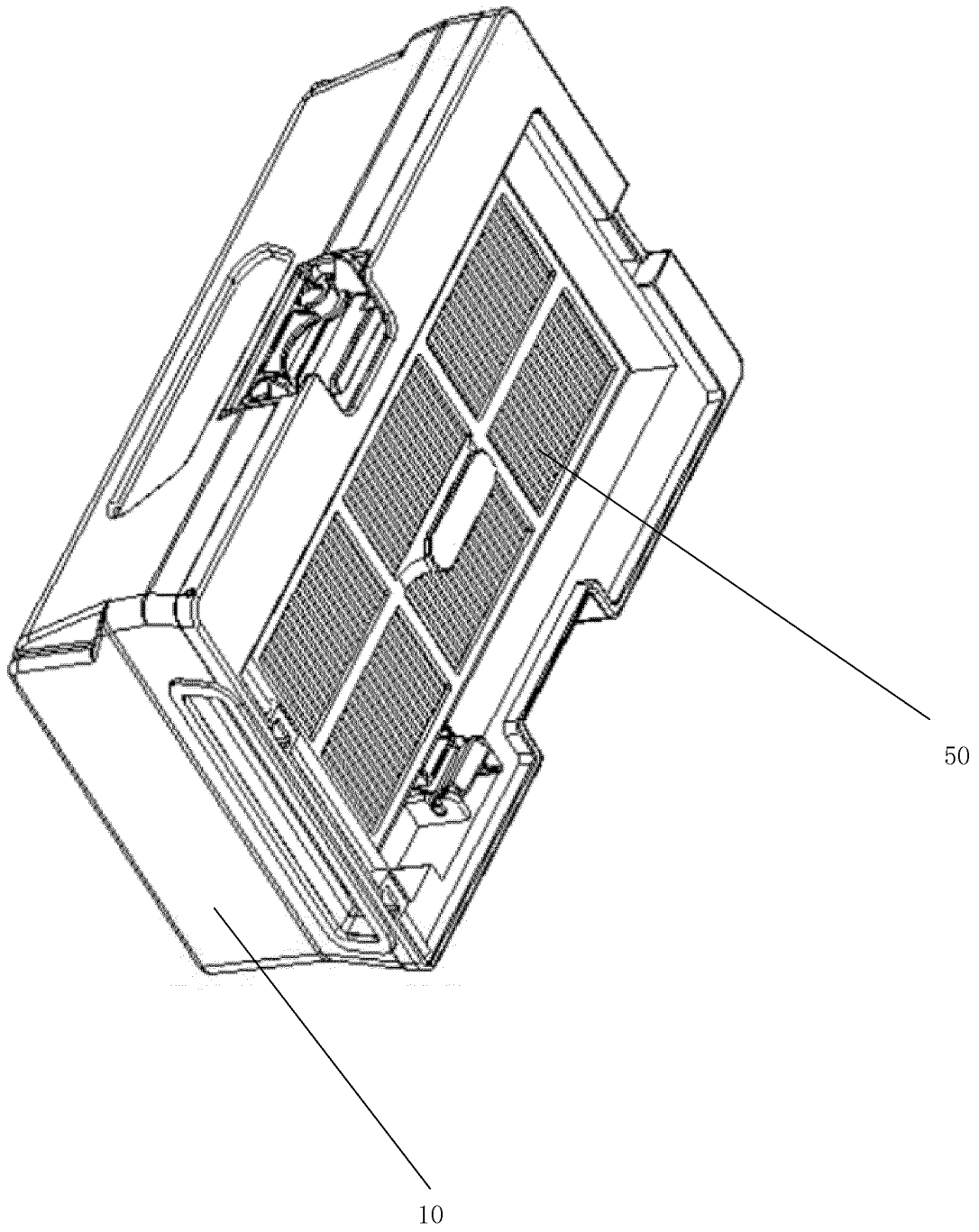

FIG. 6

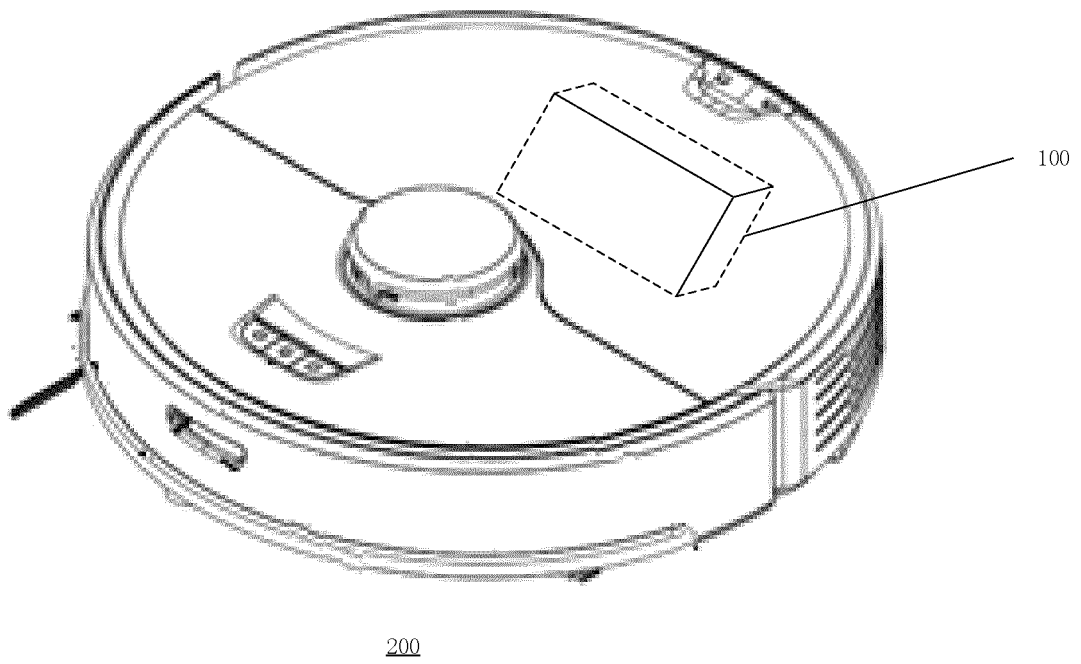

FIG. 7

INTERNATIONAL SEARCH REPORT

International application No.

PCT/CN2022/082846

5

A. CLASSIFICATION OF SUBJECT MATTER		
A47L 11/24(2006.01)i; A47L 11/40(2006.01)j		
According to International Patent Classification (IPC) or to both national classification and IPC		
B. FIELDS SEARCHED		
Minimum documentation searched (classification system followed by classification symbols)		
A47L		
Documentation searched other than minimum documentation to the extent that such documents are included in the fields searched		
Electronic data base consulted during the international search (name of data base and, where practicable, search terms used)		
WPABSC; CNTXT; WPABS; ENTXT; ENTXTC; VEN: 尘盒, 集尘, 尘, 收集, 滤网, 滤, 漏, 装; dust, collect+, filter, neglection, neglect+, dismount+, miss+		
C. DOCUMENTS CONSIDERED TO BE RELEVANT		
Category*	Citation of document, with indication, where appropriate, of the relevant passages	Relevant to claim No.
PX	CN 215305537 U (BEIJING ROBOROCK TECHNOLOGY CO., LTD.) 28 December 2021 (2021-12-28) description, paragraphs 25-45, and figures 1-7	1-10
X	CN 109106289 A (SHENZHEN WATER WORLD CO., LTD.) 01 January 2019 (2019-01-01) description, paragraphs 44-75, and figures 1-12	1-10
X	CN 108371515 A (LIAN YANMEI) 07 August 2018 (2018-08-07) description, paragraphs [0017]-[0024], and figures 1-3	1-10
A	CN 107080494 A (JIANGSU MIDEA CLEAN ELECTRIC APPLIANCE CO., LTD.) 22 August 2017 (2017-08-22) entire document	1-10
A	CN 208659189 U (JIANGSU MIDEA CLEANING APPLIANCES CO., LTD. et al.) 29 March 2019 (2019-03-29) entire document	1-10
A	US 2014359966 A1 (SAMSUNG ELECTRONICS CO., LTD.) 11 December 2014 (2014-12-11) entire document	1-10
<input checked="" type="checkbox"/> Further documents are listed in the continuation of Box C. <input checked="" type="checkbox"/> See patent family annex.		
* Special categories of cited documents:	"T" later document published after the international filing date or priority date and not in conflict with the application but cited to understand the principle or theory underlying the invention "X" document of particular relevance; the claimed invention cannot be considered novel or cannot be considered to involve an inventive step when the document is taken alone "Y" document of particular relevance; the claimed invention cannot be considered to involve an inventive step when the document is combined with one or more other such documents, such combination being obvious to a person skilled in the art "&" document member of the same patent family	
"A" document defining the general state of the art which is not considered to be of particular relevance		
"E" earlier application or patent but published on or after the international filing date		
"L" document which may throw doubts on priority claim(s) or which is cited to establish the publication date of another citation or other special reason (as specified)		
"O" document referring to an oral disclosure, use, exhibition or other means		
"P" document published prior to the international filing date but later than the priority date claimed		
Date of the actual completion of the international search	Date of mailing of the international search report	
29 May 2022	29 June 2022	
Name and mailing address of the ISA/CN	Authorized officer	
China National Intellectual Property Administration (ISA/CN) No. 6, Xitucheng Road, Jimenqiao, Haidian District, Beijing 100088, China		
Facsimile No. (86-10)62019451	Telephone No.	

55

Form PCT/ISA/210 (second sheet) (January 2015)

INTERNATIONAL SEARCH REPORT

International application No.
PCT/CN2022/082846

5

C. DOCUMENTS CONSIDERED TO BE RELEVANT		
Category*	Citation of document, with indication, where appropriate, of the relevant passages	Relevant to claim No.
A	KR 20060025429 A (SAMSUNG GWANGJU ELECTRONICS CO., LTD.) 21 March 2006 (2006-03-21) entire document	1-10
.....		

10

15

20

25

30

35

40

45

50

55

INTERNATIONAL SEARCH REPORT
Information on patent family members

International application No.
PCT/CN2022/082846

5
10
15
20
25
30
35
40
45
50
55

Patent document cited in search report			Publication date (day/month/year)	Patent family member(s)			Publication date (day/month/year)
CN	215305537	U	28 December 2021	None			
CN	109106289	A	01 January 2019	None			
CN	108371515	A	07 August 2018	None			
CN	107080494	A	22 August 2017	None			
CN	208659189	U	29 March 2019	EP	3741279	A1	25 November 2020
				WO	2019184174	A1	03 October 2019
				JP	2021514706	A	17 June 2021
				KR	20200109348	A	22 September 2020
US	2014359966	A1	11 December 2014	KR	20140144435	A	19 December 2014
				US	2015265120	A1	24 September 2015
				EP	2813169	A1	17 December 2014
KR	20060025429	A	21 March 2006	None			

REFERENCES CITED IN THE DESCRIPTION

This list of references cited by the applicant is for the reader's convenience only. It does not form part of the European patent document. Even though great care has been taken in compiling the references, errors or omissions cannot be excluded and the EPO disclaims all liability in this regard.

Patent documents cited in the description

- CN 202121515792 [0001]