



(11) **EP 4 379 130 A1**

(12) **EUROPEAN PATENT APPLICATION**

(43) Date of publication:  
**05.06.2024 Bulletin 2024/23**

(51) International Patent Classification (IPC):  
**D21F 1/02<sup>(2006.01)</sup> D21H 23/24<sup>(2006.01)</sup>**

(21) Application number: **22210936.5**

(52) Cooperative Patent Classification (CPC):  
**D21F 1/026; D21F 1/028; D21H 23/24**

(22) Date of filing: **01.12.2022**

(84) Designated Contracting States:  
**AL AT BE BG CH CY CZ DE DK EE ES FI FR GB GR HR HU IE IS IT LI LT LU LV MC ME MK MT NL NO PL PT RO RS SE SI SK SM TR**  
Designated Extension States:  
**BA**  
Designated Validation States:  
**KH MA MD TN**

(72) Inventors:  
• **BOERSMA, Tjerk**  
**3590 Diepenbeek (BE)**  
• **JASPERS, Willy**  
**6241 GK Bunde (NL)**

(71) Applicant: **SAPPI Netherlands BV**  
**6211 AA Maastricht (NL)**

(74) Representative: **Schmitz, Joseph**  
**Isler & Pedrazzini AG**  
**Giesshübelstrasse 45**  
**Postfach 1772**  
**8027 Zürich (CH)**

(54) **HEADBOX AND METHOD FOR APPLYING COATING COMPOSITIONS ONTO A MOVING WET PULP SUBSTRATE USING SAID HEADBOX**

(57) A headbox (1) for a paper machine, in particular a secondary headbox for applying a stream of a coating composition onto a moving wet pulp substrate in a paper machine, comprising a stock chamber (2), a stilling chamber (3), a slice chamber (4), a valve assembly for controlling the flow of coating composition from the stock chamber (2) into the stilling chamber (3) and for controlling the flow of coating composition from the stilling chamber (3) to the slice chamber (4), wherein the valve assembly comprises a rotatable valve body (5) and a valve case body (6), said rotatable valve body (5) being located within the valve case body (6), wherein said rotatable valve body (5) is rotatable into a closed state and into one or more opened states, wherein said rotatable valve body (5) comprises a first and second sealing element (7, 8) and said valve case body (6) comprises a first and second sealing surface (9, 10), wherein in an open state, the first sealing element (7) is at a first distance  $d_1$  from the first sealing surface (9) on the valve case body (6) forming a first clearance and thereby fluidly connecting the stock chamber (2) to the stilling chamber (3) and the second sealing element (8) is at a second distance  $d_2$  from the second sealing surface (10) on the valve case body (6) forming a second clearance and thereby fluidly connecting the stilling chamber (3) to the slice chamber (4), and wherein in an open state, the first clearance is larger than the second clearance.

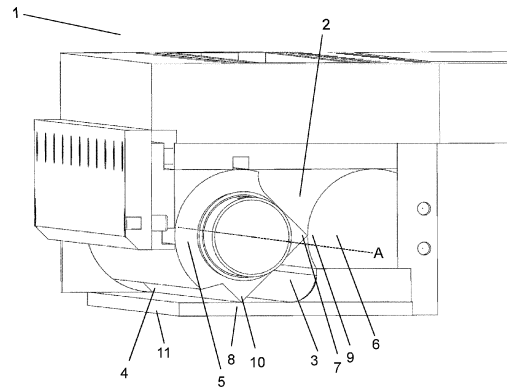

FIG. 3

**EP 4 379 130 A1**

**Description**

## TECHNICAL FIELD

5 **[0001]** The present invention relates to the field of paper machines, in general, and in particular to a headbox, such as a secondary headbox, for applying a coating composition onto a moving wet pulp substrate in a paper machine, as well as a method of applying a coating composition onto a moving wet pulp substrate in a paper machine equipped with such a headbox, a paper machine comprising such a headbox as well as the use of such a headbox in a method of applying a horizontal stream of a coating composition onto a horizontally moving wet pulp substrate in a paper machine.

10

## PRIOR ART

**[0002]** Paper machines use a moving woven mesh, also known as wire, to create a continuous paper web by filtering out the fibres held in a wet paper stock and producing a continuously moving wet mat of fibre.

15 **[0003]** In the paper machine, the wet paper stock is dispensed onto the wire mesh from a so-called headbox. The headbox essentially holds the wet paper stock and must, on one hand, keep the fibers from clumping together by generating turbulence in its interior, and on the other hand, uniformly distribute the wet paper stock across the width of the wire. Fulfilling both requirements ensures the formation of a homogenous mat of wet pulp on the wire.

20 **[0004]** It is known in the art of papermaking to add a second headbox downstream of the primary headbox to apply a different pulp blend or other coatings on top of a base pulp layer provided by the primary headbox. Such a traditional secondary headbox is normally located at a point where the base sheet is drained, i.e. at some point after the wet end section, and are a common configuration when manufacturing on linerboard.

25 **[0005]** However, in recent years, the use of novel materials as coating compositions, to be applied via a secondary headbox, has been hindered due to the special rheological properties that said materials impose on coating compositions. While secondary headbox designs are plentiful, the existing designs are mostly suitable and optimized for the application of coating compositions having low viscosity at low shear and thus, it is not possible to apply the novel materials in a way such that a homogenous layer, in width and thickness, is reliably formed, if said material exhibits high viscosity at low shear.

30 **[0006]** The formation of such a homogenous layer will in any case depend on multiple factors, such as matching of the speed at which the coating composition contacts the moving wet pulp layer from the primary headbox to the speed of the moving wet pulp layer, as well as adjusting the angle at which the coating composition contacts the moving wet pulp layer from the primary headbox, all the while warranting that the flow rate, width, thickness, rheology and consistency of the coating composition exiting the secondary head box is on-target.

35 **[0007]** There exists therefore a need to provide a headbox design that is capable of providing a homogenous stream of a coating composition, in both width and thickness, when the coating composition has is highly viscous.

## SUMMARY OF THE INVENTION

40 **[0008]** The present invention provides for a headbox design that is capable of providing a stream, such as for example a curtain, of a coating composition onto a moving wet pulp substrate in a paper machine that results in the formation of a coating layer on the wet pulp substrate that is homogenous in thickness and width. The headbox design of the present invention is particularly suited for coating compositions having a particular rheology profile, such as for example coating compositions comprising microfibrillated cellulose. It has further been found that the design of the headbox provides excellent rigidity, or less bending propensity, which leads to a more homogenous coating on the moving wet pulp substrate.

45 **[0009]** It is therefore a first object of the present invention to provide a headbox for a paper machine, in particular a secondary headbox for applying a stream, or jet, of a coating composition onto a moving wet pulp substrate in a paper machine, comprising a stock chamber, a stilling chamber and a slice chamber

50 - a valve assembly for controlling the flow of coating composition from the stock chamber into the stilling chamber and for controlling the flow of coating composition from the stilling chamber to the slice chamber

wherein the valve assembly comprises a rotatable valve body and a valve case body, said rotatable valve body being located within the valve case body ,  
 wherein said rotatable valve body is rotatable into a closed state and into one or more opened states,  
 55 wherein said rotatable valve body comprises a first and second sealing element and said valve case body comprises a first and second sealing surface ,  
 wherein in a closed state,

- a) the first sealing element is in sealing contact with a first sealing surface on the valve case body , thereby forming a first seal which seals the stock chamber from the stilling chamber, and  
 b) the second sealing element is in sealing contact with a second sealing surface on the valve case body forming a second seal, which seals the stilling chamber from the slice chamber,

5

wherein in an open state,

- a) the first sealing element is at a first distance  $d_1$  from the first sealing surface on the valve case body forming a first clearance of size  $s_1$  and thereby fluidly connecting the stock chamber to the stilling chamber and  
 b) the second sealing element is at a second distance  $d_2$  from the second sealing surface on the valve case body forming a second clearance of size  $s_2$  and thereby fluidly connecting the stilling chamber to the slice chamber, and

10

15

wherein when the rotatable valve body is rotated from an open state to the closed state, the first and second sealing elements are simultaneously moved along a circular path into sealing contact with a first and second sealing surface

wherein when the rotatable valve body is rotated from an closed state to the open state, the first and second sealing elements are simultaneously moved away along a circular path from a first and second sealing surface , and wherein

20

in any open state, the first clearance is larger than the second clearance.

**[0010]** It is a second object of the present invention to provide a paper machine comprising a primary headbox for forming a wet pulp substrate and secondary headbox according to first object of the present invention for applying a stream, or jet, of a coating composition onto a moving wet pulp substrate.

25

**[0011]** It is a third object of the present invention to provide a method of applying a stream, or jet, of a coating composition onto a moving wet pulp substrate in a paper machine, wherein the stream of a coating composition exits the slice chamber of a headbox according the first object of the present invention to provide, in its open state, and wherein the ratio of the speeds between said stream of a coating composition  $V_1$  and said moving wet pulp substrate  $V_2$  is between 0.9 and 1.1.

30

**[0012]** It is a fourth object of the present invention to provide a use of a headbox according the first object of the present invention in a method of applying a horizontal stream, or jet, of a coating composition onto a horizontally moving wet pulp substrate in a paper machine, preferably in a method according the third object of the present invention, wherein the horizontal stream of a coating composition exits the slice chamber of the headbox according the first object of the present invention, in its open state, at a horizontal speed ( $V_1$ ) and wherein the ratio of the horizontal speeds of said horizontal stream of a coating composition and horizontally moving wet pulp substrate ( $V_2$ ) is between 0.9 and 1.1.

35

**[0013]** It is a fifth object of the present invention to provide a coated paper comprising one or more substrate and one or more coating layer, said coating layer preferably comprising microfibrillated cellulose, wherein said coated paper has a Bendtsen porosity of less than 15 ml/min and/or a water and oil absorption according to Cobb Unger of less than 5 s, wherein said paper coated paper is preferably obtained via the method according to the third object of the present invention.

40

#### BRIEF DESCRIPTION OF THE DRAWINGS

**[0014]** Preferred embodiments of the invention are described in the following with reference to the drawings, which are for the purpose of illustrating the present preferred embodiments of the invention and not for the purpose of limiting the same. In the drawings,

45

Fig. 1 shows a cross-section view of the headbox (1) for a paper machine according to the present invention, comprising a stock chamber (2), which comprises a coating solution during operation, connected to a downstream stilling chamber (3) and a further downstream a slice chamber (4). A double valve assembly for controlling the flow of coating composition from the stock chamber (2) into the stilling chamber (3) and for controlling the flow of coating composition from the stilling chamber (3) to the slice chamber (4) comprises a rotatable valve body (5) and a valve case body (6), said rotatable valve body (5) being located within the valve case body (6), wherein said rotatable valve body (5) is rotatable around an axis A, and is shown in a closed state, where a first sealing element (7) is in sealing contact with a first sealing surface (9) on the valve case body (6), thereby forming a first seal which seals the stock chamber (2) from the stilling chamber (3), and a second sealing element (8) is in sealing contact with a second sealing surface (10) on the valve case body (6) forming a second seal, which seals the stilling chamber (3) from the slice chamber (4). When the rotatable valve body (5) is rotated around

55

axis A, from a closed state (shown) to the open state (shown in Fig. 2), the first and second sealing elements (7, 8) are simultaneously moved away along a circular path C from a first and second sealing surface (9, 10). The solid black cross-shaped elements in the drawing show gaskets.

5 Fig. 2 shows a cross-section view of the headbox (1) for a paper machine according to the present invention, comprising a stock chamber (2), which comprises a coating solution during operation, connected to a downstream stilling chamber (3) and a further downstream a slice chamber (4). A double valve assembly for controlling the flow of coating composition from the stock chamber (2) into the stilling chamber (3) and for controlling the flow of coating composition from the stilling chamber (3) to the slice chamber (4) comprises a rotatable valve body (5) and a valve case body (6), said rotatable valve body (5) being located within the valve case body (6), and wherein said rotatable valve body (5) is rotatable around an axis A, and is shown in an open state, where a first sealing element (7) is at a distance from a first sealing surface (9) on the valve case body (6) forming a first clearance and thereby fluidly connecting the stock chamber (2) to the stilling chamber (3) and a second sealing element (8) is at a second distance from the second sealing surface (10) on the valve case body (6) forming a second clearance and thereby fluidly connecting the stilling chamber (3) to the slice chamber (4), and where the first clearance is larger than the second clearance, and is in particular two times larger than the second clearance. In the cross-section view, the size of the first and second clearances is indicated by the first distance  $d_1$  and second distance  $d_2$ , respectively. When the rotatable valve body (5) is rotated around axis A, from an open state (shown,  $\alpha=17^\circ$ ) to the closed state (shown in Fig. 1,  $\alpha=0^\circ$ ), the first and second sealing elements (7, 8) are simultaneously moved along a circular path C into sealing contact with a first and second sealing surface (9, 10). The solid black cross-shaped elements in the drawing show gaskets.

Fig. 3 shows an open view of the headbox (1) for a paper machine according to the present invention, comprising a stock chamber (2), which comprises a coating solution during operation, connected to a downstream stilling chamber (3) and a further downstream a slice chamber (4). A double valve assembly for controlling the flow of coating composition from the stock chamber (2) into the stilling chamber (3) and for controlling the flow of coating composition from the stilling chamber (3) to the slice chamber (4) comprises a rotatable valve body (5) with an axle (5a) and a valve case body (6), said rotatable valve body (5) being located within the valve case body (6), wherein said rotatable valve body (5) is rotatable around an axis A, and is shown in a closed state, where a first sealing element (7), in the form of an edge of the rotatable valve body (5) and extending along the longitudinal axis of the rotatable valve body (5), is in sealing contact with a first sealing surface (9) on the valve case body (6), thereby forming a first seal which seals the stock chamber (2) from the stilling chamber (3), and a second sealing element (8) in the form of an edge of the rotatable valve body (5) and extending along the longitudinal axis of the rotatable valve body (5), is in sealing contact with a second sealing surface (10) on the valve case body (6) forming a second seal, which seals the stilling chamber (3) from the slice chamber (4). When the rotatable valve body (5) is rotated around axis A, from a closed state (shown) to the open state (not shown), the first and second sealing elements (7, 8) are simultaneously moved away along a circular path C (not shown) from a first and second sealing surface (9, 10).

#### 40 DESCRIPTION OF PREFERRED EMBODIMENTS

**[0015]** In a first object of the present invention provides for a headbox (1) for a paper machine, in particular a secondary headbox for applying a stream of, preferably a jet of, a coating composition onto a moving wet pulp substrate in a paper machine, comprising

- 45
- a stock chamber (2)
  - a stilling chamber (3)
  - a slice chamber (4)
  - a valve assembly for controlling the flow of coating composition from the stock chamber (2) into the stilling chamber (3) and for controlling the flow of coating composition from the stilling chamber (3) to the slice chamber (4)
- 50

wherein the valve assembly comprises a rotatable valve body (5) and a valve case body (6), said rotatable valve body (5) being located within the valve case body (6),

wherein said rotatable valve body (5) is rotatable into a closed state and into one or more opened states,

55 wherein said rotatable valve body (5) comprises a first and second sealing element (7, 8) and said valve case body (6) comprises a first and second sealing surface (9, 10), wherein in a closed state,

a) the first sealing element (7) is in sealing contact with a first sealing surface (9) on the valve case body

(6), thereby forming a first seal which seals the stock chamber (2) from the stilling chamber (3), and/or  
 b) the second sealing element (8) is in sealing contact with a second sealing surface (10) on the valve case  
 body (6) forming a second seal, which seals the stilling chamber (3) from the slice chamber (4),

5 wherein in an open state,

a) the first sealing element (7) is at a first distance  $d_1$  from the first sealing surface (9) on the valve case  
 body (6) forming a first clearance and thereby fluidly connecting the stock chamber (2) to the stilling chamber  
 (3) and

10 b) the second sealing element (8) is at a second distance  $d_2$  from the second sealing surface (10) on the  
 valve case body (6) forming a second clearance and thereby fluidly connecting the stilling chamber (3) to  
 the slice chamber (4), and

15 wherein when the rotatable valve body (5) is rotated from an open state to the closed state, the first and second  
 sealing elements (7, 8) are simultaneously moved along a circular path into sealing contact with a first and  
 second sealing surface (9, 10)

wherein when the rotatable valve body is rotated from an closed state to the open state, the first and second  
 sealing elements (7, 8) are simultaneously moved away along a circular path C from a first and second sealing  
 surface (9, 10),

20 and wherein, in an open state, the first clearance is larger than the second clearance.

**[0016]** In the headbox according to the present invention, the ratio ( $d_1/d_2$ ) between distance  $d_1$  and distance  $d_2$  is  
 more than 1, preferably is between 1 and 3 and/or the distance  $d_2$  is between 0.4 and 20 mm, preferably between 0.4  
 and 10 mm, more preferably between 0.8 and 3 mm. 1. In a more preferred embodiment, in any open state, ( $d_1/d_2$ )  
 25 between distance  $d_1$  and distance  $d_2$  is constant, and is preferably about 2.

**[0017]** The headbox (1) according to the present invention is preferably a secondary headbox for applying a stream  
 of a coating composition onto a moving wet pulp substrate in a paper machine, which wet pulp substrate is formed by  
 dispensing a stock made of water, paper pulp and suitable additives from a primary headbox onto the moving wire mesh  
 of the paper machine in the wet end of the paper machine.

30 **[0018]** The headbox (1) according to the present invention is preferably equipped with one or more pressure sensors,  
 which one or more pressure sensors may be disposed in the stock chamber (2), stilling chamber (3) or slice chamber  
 (4), or in each one, or in at least two of them. By monitoring the pressure within the headbox, it is possible to control the  
 pressure within the headbox, and thereby control the speed  $V_1$  of the jet of coating composition. Thus, in a preferred  
 embodiment, the one or more pressure sensors are connected to a jet speed control unit, which control unit is capable  
 35 receiving a pressure sensor signal and of adjusting the pressure in the headbox (1), depending on the pressure signal  
 received, via a pressure control unit fluidly connected to the headbox (1), to ensure the speed  $V_1$  of the jet of coating  
 composition is controlled such as to not deviate from a set value and/or such as to achieve the ratio of the speeds of  
 said jet of a coating composition  $V_1$  and moving wet pulp substrate  $V_2$  is between 0.9 and 1.1.

40 **[0019]** The stock from which the wet pulp substrate is formed may comprise one or more pulps, preferably wood pulps,  
 which may further be chemical wood pulps such as for example sulphite pulp or kraft pulp. The chemical wood pulps  
 may further be bleached chemical wood pulps.

**[0020]** Generally, a mixture of pulps, in particular a mixture of chemical softwood pulp and chemical hardwood pulp,  
 is used in the stock from which the wet pulp substrate is formed.

**[0021]** Consequently, the wet pulp substrate formed from said stock comprises the one or more pulps given above.

45 **[0022]** Because a primary headbox essentially holds the stock from which wet pulp substrate is formed, in some  
 designs, turbulence is generated its interior with a mixing device, usually a submerged fan or perforated rollers spinning  
 within the stock.

**[0023]** In contrast, the headbox (1) according to the present invention, which is preferably a secondary headbox, does  
 not comprise a mixing device in one embodiment, in particular in the stock chamber (2) and the stilling chamber (3). The  
 50 needed shear for stable operation of the headbox is provided by inner surfaces of the headbox (1), which deviate the  
 stock in the headbox (1) as it passes through the headbox (1), in particular in the stilling chamber (3).

**[0024]** The headbox (1) according to the present invention is preferably a secondary headbox for applying a stream  
 of a coating composition onto a moving wet pulp substrate in a paper machine, which stream of a coating composition  
 is preferably in the form of a curtain of a coating composition. The curtain form is mainly due to the outline of the second  
 55 clearance that is formed when the second sealing element (8) on the rotatable valve body (5) moves away from the  
 second sealing surface (10) on the valve case body (6), once the rotatable valve body (5) is rotated into an open position.  
 Thus, the thickness of the stream, or curtain, can be controlled via the height of the second clearance achieved by the  
 opened rotatable valve body (5). Likewise, the width of the stream, or curtain, can be controlled via the width of the

second clearance achieved by the opened rotatable valve body (5).

**[0025]** The headbox (1) according to the present invention is preferably a secondary headbox for applying a stream of a coating composition onto a moving wet pulp substrate in a paper machine, which moving wet pulp substrate moves at a speed  $V_2$ .

**[0026]** The headbox (1) according to the present invention is preferably a secondary headbox for applying a stream of a coating composition onto a moving wet pulp substrate in a paper machine, which headbox (1) comprises a stock chamber (2) for providing a coating composition to the downstream stilling chamber (3). During operation of the headbox (1), the stock chamber (2) thus holds a coating composition. In a preferred embodiment of the headbox (1) according to the present invention, the headbox (1), and in particular the stock chamber (2), is preferably pressurized, and more preferably is configured to be controllable with respect to the pressure within the stock chamber (2). In one embodiment, the stock chamber (2) is equipped with a plurality of inlets, which inlets are each fluidly connected to a plurality of conveyor pipes, that are suitable for conveying a preferably pressurized coating composition into the stock chamber (2). In general, the coating composition can be held in a preferably pressurized, holding tank from which the plurality of conveyor pipe lead to the plurality of inlets of the stock chamber (2). In one embodiment, the stock chamber (2) is equipped with a plurality of inlets, which are distributed along the width of the headbox, i.e. in a direction parallel to the rotation axis of rotatable valve body (5).

**[0027]** In one embodiment, a lower part of the stock chamber (2) is tapered towards the first seal in the headbox (1), which seals the stock chamber (2) from the downstream stilling chamber (3), in the closed state. In a further embodiment, the lower part of the stock chamber (2) is tapered towards the first seal in the headbox (1), which seals the stock chamber (2) from the downstream stilling chamber (3), in the closed state, wherein one surface of the stock chamber (2), in the lower part, is a substantially planar surface formed by the rotatable valve body (5) and the opposed surface to that surface is a convex surface of the valve case body (6). The tapered form of the stock chamber (2) ensures that a coating composition passing through, from stock chamber (2) to stilling chamber (3), is accelerated and thus experiences more shear.

**[0028]** The headbox (1) according to the present invention is preferably a secondary headbox for applying a stream of a coating composition onto a moving wet pulp substrate in a paper machine, which headbox (1) comprises a stilling chamber (3) for providing a coating composition to the downstream slice chamber (4). During operation of the headbox (1), the stilling chamber (3) thus holds a coating composition.

**[0029]** In a preferred embodiment of the headbox (1) according to the present invention, the headbox (1), and in particular the stilling chamber (3), is preferably pressurized, and more preferably is configured to be controllable with respect to the pressure within the stilling chamber (3). The stilling chamber (3) is fluidly connected to the stock chamber (2), in an open state, and thus the pressure of the stock chamber (2) is established in the stilling chamber (3) once the rotatable valve body (5) is rotated into an open state. The stilling chamber (3) may comprise one or more surfaces that are configured to either induce or avoid turbulence when a coating composition flows through the stilling chamber (3), i.e. between the first sealing surface (9) and the second sealing surface (10).

**[0030]** In one embodiment, the stilling chamber (3) comprises a concave surface positioned in between the first sealing surface (9) and the second sealing surface (10). By forcing the coating composition along a given path, the coating composition is sheared, such as to achieve a thinning of the coating composition to allow a homogenous flow of coating composition across the headbox (1).

**[0031]** In one embodiment, in the headbox (1) according to the present invention, either when moving into an open or closed state, the first and second sealing elements (7, 8) are simultaneously moved along the same circular path C.

**[0032]** The headbox (1) according to the present invention is preferably a secondary headbox for applying a stream of a coating composition onto a moving wet pulp substrate in a paper machine, which headbox (1) comprises a slice chamber (4) for providing a stream of a coating composition ejected via the clearance formed by the second sealing element (8) and the second sealing surface (10), in a opened state of the rotatable valve body (5).

**[0033]** Thus, the thickness of the stream can be controlled via the height of the second clearance achieved by the opened rotatable valve body (5). Likewise, the width of the stream can be controlled via the width of the second clearance achieved by the opened rotatable valve body (5).

**[0034]** The headbox (1) according to the present invention is preferably a secondary headbox for applying a stream of a coating composition onto a moving wet pulp substrate in a paper machine, which headbox (1) comprises a valve assembly, which comprises a rotatable valve body (5) and a valve case body (6), where the rotatable valve body (5) is located within the valve case body (6) in a rotatable manner. The valve assembly controls the flow of coating composition from the stock chamber (2) into the stilling chamber (3) and for controlling the flow of coating composition from the stilling chamber (3) to the slice chamber (4).

**[0035]** The rotatable valve body (5) and the valve case body (6) may be formed of any suitable material, and are preferably formed of metal such as for example brass, bronze, copper or steel. In a preferred embodiment, the rotatable valve body (5) and the valve case body (6) are formed of stainless steel and alloys thereof.

**[0036]** The rotatable valve body (5) is rotatable with respect to the valve case body (6), into a closed state, and into

one or more opened states. In its opened state, a coating composition can flow through the headbox (1). The rotatable valve body (5) can be adjusted by rotation to be in a more open state or a less open state, which in turn adjusts the size of the resulting clearance at the first and second seal, and ultimately regulating the pressure, speed and flow rate of the coating composition exiting the second clearance. When the rotatable valve body (5) is rotated from an closed state to the open state, the first and second sealing elements (7, 8) are simultaneously moved away along a circular path from a first and second sealing surface (9, 10), and since the rotatable valve body (5) has predefined geometry and/or cross-sectional shape, together with the valve case body (6), the size ratio between first and second clearance is determined by the degree of opening and the geometry and/or cross-sectional shape of the rotatable valve body (5) and valve case body (6). In the headbox (1) according to the present invention, the rotatable valve body (5) and the valve case body (6) have a geometry and/or cross-sectional shape such that in any open state, the first clearance is larger than the second clearance. In a more preferred embodiment, the rotatable valve body (5) and the valve case body (6) have a geometry and/or cross-sectional shape such that in any open state, the first clearance is larger than the second clearance and the size of the first clearance and size of the second clearance have a constant ratio, which ratio is preferably about 2, and which may be between 1 and 3. Because the first clearance is larger, the stilling chamber (3) can be provided with sufficient coating composition from the stock chamber (2) and warrant the pressure that is provided from the pressure in the stock chamber (2).

**[0037]** In one embodiment of the headbox according to claim 1, wherein the first clearance is larger than the second clearance by a factor of more than 1, preferably by a factor of more than 1 and up to 3. By reducing the size of the clearance, it is possible to provide a progressive increase of speed and/or shear imparted onto the coating composition, as it passes through the headbox (1), which leads to a more stable stream of coating composition being discharged from the headbox (1).

**[0038]** The coating composition, upon being forced through the first larger clearance, is accelerated and exposed to a first amount of shear, and when forced through the second clearance, is further accelerated and exposed to a second amount of shear. In coating compositions that are shear-thinning, the consecutive acceleration and/or shearing leads to a decrease in viscosity which enables the coating composition to be coated homogenously onto the moving wet pulp substrate.

**[0039]** It is understood that the clearances, which on one side may be delimited in width, which is generally constant, by the sidewalls of the headbox (1) which may for example be formed by lateral walls of the valve case body (6) or by separate wall plates affixed to the valve case body (6), and which may be delimited in height by the respective sealing elements of the rotatable valve body (5) and sealing surfaces (9, 10) of the valve case body (6), in the open state, have a rectangular shape, where the larger sides correspond to the width and the smaller sides correspond to the height.

**[0040]** In one embodiment, the rotatable valve body (5), in an open state, leads to a height of the second clearance of from 0.3 to 5 mm, preferably of from 0.8 mm to 3 mm, which translates into essentially the same height, or stated alternatively, thickness, of the stream of a coating composition exiting the slice chamber (4).

**[0041]** The rotatable valve body (5) comprises a first and second sealing element (7, 8) and said valve case body (6) comprises a first and second sealing surface (9, 10), wherein in a closed state, the first sealing element (7) is in sealing contact with a first sealing surface (9) on the valve case body (6), thereby forming a first seal which seals the stock chamber (2) from the stilling chamber (3), and the second sealing element (8) is in sealing contact with a second sealing surface (10) on the valve case body (6) forming a second seal, which seals the stilling chamber (3) from the slice chamber (4), wherein in an open state, the first sealing element (7) is spaced from the first sealing surface (9) on the valve case body (6), preferably by a first distance  $d_1$ , thereby forming a first clearance having a first size  $s_1$ , and thereby fluidly connecting the stock chamber (2) to the stilling chamber (3) and the second sealing element (8) is spaced from the second sealing surface (10) on the valve case body (6), preferably by a second distance  $d_2$ , thereby forming a second clearance having a second size  $s_2$  and thereby fluidly connecting the stilling chamber (3) to the slice chamber (4).

**[0042]** The headbox (1) according to the present invention is preferably a secondary headbox for applying a stream of a coating composition onto a moving wet pulp substrate in a paper machine, and is rotatable as a whole such as to modify the direction of the stream of the coating composition exiting the slice chamber (4) and/or wherein the headbox (1) is moveable as a whole in one or more directions, preferably at least in a direction perpendicular to the plane of the moving wet pulp substrate, such as to modify the direction of the stream of the coating composition contacting the moving wet pulp substrate in a paper machine, which moving wet pulp substrate is preferably moving in a horizontal direction. The direction, or angle, at which the stream of a coating composition contacts the moving wet pulp substrate in the paper machine will depend on the position and angle of the headbox (1) relative to the plane the moving wet pulp substrate. For instance, when the headbox (1) is moved away in at least in a direction perpendicular to the plane of the moving wet pulp substrate, the stream will be deviated from its original direction towards the direction of gravity, the longer it is allowed to fall. On the other hand, the initial angle will make that deviation more or less pronounced if headbox (1) is rotated such that the direction of the stream of the coating composition exiting the slice chamber (4) is closer or further from the direction of gravity. In one embodiment, the headbox (1) according to the present invention is rotatable as a whole and/or moveable as a whole, via linear or rotary actuators coupled to the headbox (1) as a whole, where preferably

linear actuators are configured such as to move the headbox (1) as a whole and/or rotary actuators are configured such as to rotate the headbox (1) as a whole.

**[0043]** In one embodiment, the headbox (1) according to the present invention is rotatable as a whole by an angle of  $-15$  to  $15^\circ$  with respect to the plane of the moving wet pulp substrate in the paper machine. Thus, the headbox (1) according to the present invention is in general rotatable towards, or away from, the plane of the moving wet pulp substrate

**[0044]** In one embodiment, the headbox (1) according to the present invention is moveable as a whole to a distance of from 10 to about 80 mm, at least in a direction perpendicular to the plane of the moving wet pulp substrate. It is noted that the headbox (1) according to the present invention may also be moveable along the direction of movement of the moving wet pulp substrate in the paper machine. This allows the headbox (1) to be positioned above a section of the moving wet pulp substrate in the paper machine that is either upstream or downstream, or stated alternatively, closer or farther from a primary headbox (1), in the direction of movement of the moving wet pulp substrate in the paper machine.

**[0045]** In one embodiment the headbox (1) according to the present invention is positioned in the wet end section of the paper machine, and is in particular positioned in the wet end section where the moving wet pulp substrate has a solids content of less than 20% by weight, or of about 4 to 20%, preferably of about 4 to 8% by weight.

**[0046]** In one embodiment, the headbox (1) according to the present invention the rotatable valve body (5) has an elongated shape, and may be formed as shaft, which rotatable valve body is rotatable around a longitudinal axis (A) of the rotatable valve body (5). In preferred embodiment, the distance in radial direction, from the longitudinal axis (A) of the rotatable valve body (5) to the first sealing element (7) is equal to the distance in radial direction, from the longitudinal axis (A) of the rotatable valve body (5), to the second sealing element (8). In one embodiment, the rotatable valve body (5) may have a length, along its longitudinal axis, of about from 1 m to about 8 m, preferably a width of about from about 2 m to about 7 m. Thus, in an embodiment of the headbox according to the present invention, the rotatable valve body (5), being preferably a shaft, is rotatable along a longitudinal axis (A) of the shaft, wherein the first and second sealing elements (7, 8) are located at the same radial distance from the longitudinal axis (A) of the shaft.

**[0047]** In one embodiment, the headbox (1) according to the present invention, the rotatable valve body (5) comprises an axle extending along a longitudinal axis (A) of the rotatable valve body (5), which axle is coupled to a controllable rotary driving means, such as to rotate the rotatable valve body (5) in one or the other direction. In one embodiment, the axle extending along a longitudinal axis (A) of the rotatable valve body (5) and the rotatable valve body (5) are made integrally from one piece of material, such as steel, for example by machining from one blank. Suitable technologies include milling, turning or combinations of both. The rotatable valve body (5) is preferably made from one piece of a massive material, i.e. the rotatable valve body (5) is not hollow.

**[0048]** In one embodiment, the headbox (1) according to the present invention, the rotatable valve body (5) comprises one or more rods connected via an articulation to a periphery of the rotatable valve body (5), which rod(s) may for example be coupled to a controllable linear driving means, such as to rotate the rotatable valve body (5) in one or the other direction. In one embodiment, the axle extending along a longitudinal axis (A) of the rotatable valve body (5) and the rotatable valve body (5) are made integrally from one piece of material, such as steel, for example by machining from one blank. Suitable technologies include milling, turning or combinations of both.

**[0049]** In one embodiment, the headbox (1) according to the present invention, the first and/or second sealing elements (7, 8) are formed by sealing ribs, in particular sealing ribs extending, in a preferably rectilinear manner, in parallel to a longitudinal axis (A) of the rotatable valve body (5), said ribs preferably having a rounded, square or pointed tip. In one embodiment, the headbox (1) according to the present invention, the first and second sealing elements (7, 8) are formed by rectilinear edges extending in parallel to a longitudinal axis (A) of the rotatable valve body (5), preferably having a square tip. In one embodiment, the first and second sealing elements (7, 8) are formed by rectilinear edges extending in parallel to a longitudinal axis (A) of the rotatable valve body (5), preferably having a square tip, and are connected to each other via a planar surface spanning between the first and second sealing elements (7, 8). In an alternative embodiment, the first and second sealing elements (7, 8) are formed by rectilinear edges extending in parallel to a longitudinal axis (A) of the rotatable valve body (5), preferably having a square tip, and are connected to each other via a non-planar surface, which may be concave or convex, spanning between the first and second sealing elements (7, 8). It is understood that the sealing elements may be formed integrally on the rotatable valve body (5), and may be obtained from machining a blank into a rotatable valve body (5) with sealing elements. Alternatively, the sealing elements may be formed separately from the rotatable valve body (5) and fixed to the rotatable valve body (5).

**[0050]** In one embodiment, the headbox (1) according to the present invention, in a closed state, the rotatable valve body (5) in the headbox (1) is at a rotation angle  $\alpha$  of  $0^\circ$ , i.e. when both seals are formed by contact between the sealing elements and the sealing surfaces (9, 10), and in an opened state, the rotatable valve body (5) in the headbox (1) is at a rotation angle  $\alpha$  of up to  $40^\circ$ , e.g. between  $1$  and  $40^\circ$ .

**[0051]** In one embodiment, in the headbox (1) according to the present invention, the rotatable valve body (5) has a cross-sectional shape, in a direction perpendicular to its longitudinal axis, that is in partially circular, wherein the circular section of the cross-sectional shape of the rotatable valve body (5) is slidingly in sealing contact with valve case body (6). In one embodiment, the circular section of the cross-sectional shape of the rotatable valve body (5) is slidingly in

sealing contact with a circular recess in the valve case body (6), or alternatively is slidingly in sealing contact with a circular recess in the valve case body (6) comprising additionally one or two gaskets. The partially circular section of the rotatable valve body (5) ensures that the rotatable valve body (5) may be rotated into either open or closed state of the headbox (1) while keeping in sealing contact with gaskets that are located on the valve case body (6). In one embodiment, the one or two gaskets are held in one or more recesses, respectively, that are formed in the valve case body (6).

**[0052]** In one embodiment, in the headbox (1) according to the present invention, the first sealing surface (9) is a convex surface of the valve case body (6), said convex surface having preferably a circular shape. When the first sealing surface (9) is a convex surface of the valve case body (6), the flow of a coating composition flowing through the clearance, from the stock chamber (2) to the stilling chamber (3) that is formed in an open state of the headbox (1), is directed by the convex surface of the valve case body (6).

**[0053]** In one embodiment, in the headbox (1) according to the present invention, the second sealing surface (10) is a planar surface of the valve case body (6). When the second sealing surface (10) is a planar surface of the valve case body (6), the flow of a coating composition flowing through the clearance, from the stilling chamber (3) to the slice chamber (4) that is formed in an open state of the headbox (1) is directed by the planar surface of the valve case body (6), thereby providing a stable and unidirectional stream, or jet, of coating composition. In one embodiment, the planar surface of the valve case body (6) extends in opposing directions, with respect to the second seal, i.e. both in an upstream direction and an downstream direction with respect to the flow of a coating composition,

**[0054]** In one embodiment, in the headbox (1) according to the present invention, the stilling chamber (3) comprises a concave surface on the valve case body (6), in between the first sealing surface (9) and the second sealing surface (10). In one embodiment, the convex surface of the first sealing surface (9) on the valve case body (6) transitions into the concave surface on the valve case body (6) of the stilling chamber (3). Thereby, in an open state, the flow of a coating composition in the headbox (1) across the first clearance is diverted consecutively in two different directions, first by the convex surface of the first sealing surface (9) on the valve case body (6) and secondly by the concave surface on the valve case body (6) of the stilling chamber (3). In one embodiment, the concave surface on the valve case body (6) of the stilling chamber (3) is configured such that it directs the flow of a coating composition towards the second clearance and/or in a direction that lies in the plan of the planar surface of the valve case body (6). In that case, the concave surface on the valve case body (6) of the stilling chamber (3) transitions into the planar surface of the valve case body (6).

**[0055]** In one embodiment, in the headbox (1) according to the present invention, in an open state, the slice chamber (4), at the second sealing element (8) and second sealing surface (10), forms a clearance in the form of a horizontal rectangular slit, for ejecting the stream, or curtain, of a coating composition from the stilling chamber (3) into the slice chamber (4), where the height of the clearance, and consequently, of the horizontal slit is of from 0.3 to 5 mm, preferably of from 0.8 mm to 3 mm. In one embodiment, the width of the horizontal rectangular slit is about from 1 m to about 8 m, preferably about from about 2 m to about 7 m.

**[0056]** In one embodiment, in the headbox (1) according to the present invention, the slice chamber (4) comprises, at its downstream end, a bottom lip (11) for guiding the stream of a coating composition exiting the slice chamber (4) through the second clearance. In one embodiment, the bottom lip (11) has a variable length, since when the rotatable valve body (5) is rotated into an open position, the second sealing element (8) moves away from the second sealing surface (10) along a circular path thereby also moves the second clearance, where the jet is formed, further downstream of the intended direction of flow of the coating composition. The coating composition, when the headbox (1) is in an open state, leaves the stilling chamber (3) through the second clearance into the slice chamber (4) in the form of a stream, or jet, of a coating composition and subsequently leaves the slice chamber (4) to fall onto the moving wet pulp substrate in a paper machine. A bottom lip extending from the slice chamber (4) allows creating a stable stream or jet of a coating composition. The length of the bottom lip, in a closed state of the headbox (1), is fix, and defined as the distance between the second seal and the downstream end of the bottom lip, and may be, for example 32 mm. The length of the bottom lip, in an open state of the headbox (1), is variable instead of fix, and is inferior to the length of the bottom lip, in a closed state of the headbox (1), and is defined as the distance between the second clearance, in an open state of the headbox (1), and the downstream end of the bottom lip, and may be of from 4 mm to 32 mm, preferably of from 9 to 17 mm.

**[0057]** It is a second object of the present invention to provide a paper machine comprising a primary headbox (1) for forming a wet pulp substrate and secondary headbox (1) according to first object of the present invention for applying a stream of a coating composition onto a moving wet pulp substrate. A paper machine according to the present invention is capable of producing paper having a uniform coating, in thickness and composition, in an economical and simplified way, as the headbox (1) is especially rigid due to its design and can deliver a stable jet of coating composition. In particular, the paper machine according to the present invention is capable of producing paper having a uniform coating of microfibrillated cellulose, which is exceptionally difficult to apply such that the coating is uniform.

**[0058]** It is a third object of the present invention to provide a method of applying a stream of a coating composition

onto a moving wet pulp substrate in a paper machine, wherein the stream of a coating composition exits the slice chamber (4) of a headbox (1) according to the first object of the present invention to provide, in its open state, and wherein the ratio of the speeds between said stream of a coating composition V1 and said moving wet pulp substrate V2 is between 0.9 and 1.1. When the ratio of the speeds is in the aforementioned range, the coating, upon touching down on the moving substrate is neither overstretched nor compressed by the moving substrate, which avoids major shear in the bulk of the coating composition at the time of touching down.

**[0059]** It is noted that method of applying a stream of a coating composition onto a moving wet pulp substrate in a paper machine according to the present invention, the stilling chamber (3) is completely filled with a coating composition during operation of the headbox (1), so that no air cavity, or air cushion is formed.

**[0060]** In the method of applying a stream of a coating composition onto a moving wet pulp substrate in a paper machine according to the present invention, the stream of a coating composition can be applied onto a moving wet pulp substrate in a paper machine according to the second object such that the stream of a coating composition contacting the moving wet pulp substrate contacts the moving wet pulp substrate at an angle of between 3 and 75°, preferably of 15 to 40°. Controlling the angle at which a coating composition can be applied onto a moving wet pulp substrate can be useful when adjusting the degree of shear that is imparted on the coating composition immediately after contacting the moving wet pulp substrate. At smaller angles, the lateral shear is minimized, as the stream of a coating composition gets barely deflected whereas at larger angles, the stream of a coating composition gets deflected significantly in the direction of the moving wet pulp substrate.

**[0061]** In the method of applying a stream of a coating composition onto a moving wet pulp substrate in a paper machine according to the present invention, the length of the falling stream of a coating composition is between 3 mm and 500 mm. The length of the falling stream of a coating composition corresponds to the distance between the point where the stream leaves the bottom lip (11) extending from the slice chamber (4) to the point where the stream of a coating composition contacts the moving wet pulp substrate.

**[0062]** In the method of applying a stream of a coating composition onto a moving wet pulp substrate in a paper machine according to the present invention, the flow rate of the stream of a coating composition is in the range of 50 till 4000 l/min per meter width of the second clearance. In one embodiment, the width of the stream of a coating composition is in the range of about from 1 m to about 8 m, preferably a width of about from about 1,5 m to about 5 m, or from about 2 m to about 7 m.

**[0063]** In the method of applying a stream of a coating composition onto a moving wet pulp substrate in a paper machine according to the present invention, the speed of the stream of a coating composition is in the range of 50 to 700 m/min or may be in the range of 50 to 1200 m/min.

**[0064]** In the method of applying a stream of a coating composition onto a moving wet pulp substrate in a paper machine according to the present invention, the coat weight of microfibrillated cellulose that can be applied to the wet pulp substrate is of from 3 to 20 gr/m<sup>2</sup> in dry weight (air dry, *lutro*).

**[0065]** In the method of applying a stream of a coating composition onto a moving wet pulp substrate in a paper machine according to the present invention, the coating composition comprises microfibrillated cellulose. Preferably the coating composition is an aqueous suspension of microfibrillated cellulose. When the coating composition comprises microfibrillated cellulose, the microfibrillated cellulose may be comprised in an amount of less than 2.5 weight percent, based on the total weight of the coating composition, more preferably in an amount of from 0.5 to 2.0 weight percent, even more preferably in an amount of 0.8 to 1.0 weight percent.

**[0066]** In the method of applying a stream of a coating composition onto a moving wet pulp substrate in a paper machine according to the present invention, when the coating composition comprises microfibrillated cellulose, the microfibrillated cellulose is preferably microfibrillated cellulose made from hardwood. The microfibrillated cellulose enzymes, shear thinning

**[0067]** While coating compositions comprising microfibrillated cellulose are a prominent example of coating compositions that can be applied with the headbox (1) according to the present invention, and in the method of applying a stream of a coating composition onto a moving wet pulp substrate in a paper machine according to the present invention, other coating compositions that may be applied are coating compositions that, in general, are shear-thinning and/or which have a viscosity of about 5 to 100 mPas when under shear rate of about 1000 to 8000 s<sup>-1</sup>, when measured according to ISO 3219 on a Physica Anton Paar MCR 300 using spindle CC27 SN4989 and cup CC27 SS43953.

**[0068]** In the method of applying a stream of a coating composition onto a moving wet pulp substrate in a paper machine according to the present invention, and particularly in the wet end section of the paper machine, the moving wet pulp substrate has a solids content of less than 20% by weight, about 4 to 20%, preferably of 4 to 8% by weight, based on the total weight of the moving wet pulp substrate. By complement, the remaining weight is formed by at least 80% by weight of aqueous liquids such as water. It is believed that since the water content in the moving wet pulp substrate is high, an entanglement between the loosened wet pulp substrate fibers and the microfibrillated fibers of the coating composition is thereby enhanced, and therefore results in better adhesion between these layers in the final paper product.

**[0069]** It is a fourth object of the present invention to provide a use of a headbox (1) according the first object of the present invention in a method of applying a horizontal stream of a coating composition onto a horizontally moving wet pulp substrate in a paper machine, preferably in a method according the third object of the present invention, wherein the horizontal stream of a coating composition exits the slice chamber (4) of the headbox (1) according the first object of the present invention, in its open state, at a horizontal speed (V1) and wherein the ratio of the horizontal speeds of said horizontal stream of a coating composition and horizontally moving wet pulp substrate (V2) is between 0.9 and 1.1.

EXAMPLES

**[0070]** A coating composition comprising microfibrillated cellulose at about 8 g/l was prepared and provided to a headbox (1) according to the present invention via feeding lines placed along the longitudinal dimension of the headbox (1) (i.e. transverse paper machine direction), and fed to the stock chamber (2) of the headbox (1) at about a pressure of 51 kPa. The headbox (1) was then opened by an angle of 14 °, such as to provide a jet having a thickness of 1.4 mm and of a width of 1000 mm, at a flow rate of 840 l/min per meter width of the second clearance of the headbox (1). The angle of the headbox (1) with respect to the plane of the moving wet substrate was about 12° and the headbox (1) was positioned at about 5mm above the moving wet substrate. The velocity of the moving wet substrate and the velocity of the jet exiting the headbox (1) was 10 m/s and 10,08 m/s, respectively.

**[0071]** The moving wet substrate was prepared by discharging a stock having a consistency of about 10 g/l of a chemical wood pulp having refining degree more than 90 °SR. The weight of the coating composition on the moving wet substrate was checked by online measuring of the freshly deposited coating composition and found to be homogenous across the entire width, and to be about 14 gr/m<sup>2</sup>.

**[0072]** In the paper product obtained according to the above, the Bendtsen porosity was dropped lower than 15 ml/min and also Cobb Unger was dropped lower than 5 s. Bendtsen porosity was determined according to ISO 5636-1,3; and Cobb Unger was determined according to SCAN-P 37:77.

LIST OF REFERENCE SIGNS

**[0073]**

|   |                  |    |                        |
|---|------------------|----|------------------------|
| 1 | headbox          | 7  | first sealing element  |
| 2 | stock chamber    | 8  | second sealing element |
| 3 | stilling chamber | 9  | first sealing surface  |
| 4 | slice chamber    | 10 | second sealing surface |
| 5 | valve body       | 11 | lip                    |
| 6 | valve case body  |    |                        |

**Claims**

1. A headbox (1) for a paper machine, in particular a secondary headbox for applying a stream of a coating composition onto a moving wet pulp substrate in a paper machine, comprising

- a stock chamber (2)
- a stilling chamber (3)
- a slice chamber (4)
- a valve assembly for controlling the flow of coating composition from the stock chamber (2) into the stilling chamber (3) and for controlling the flow of coating composition from the stilling chamber (3) to the slice chamber (4)

wherein the valve assembly comprises a rotatable valve body (5) and a valve case body (6), said rotatable valve body (5) being located within the valve case body (6), wherein said rotatable valve body (5) is rotatable into a closed state and into one or more opened states, wherein said rotatable valve body (5) comprises a first and second sealing element (7, 8) and said valve case body (6) comprises a first and second sealing surface (9, 10),

wherein in a closed state,

a) the first sealing element (7) is in sealing contact with a first sealing surface (9) on the valve case body (6), thereby forming a first seal which seals the stock chamber (2) from the stilling chamber (3), and/or  
 b) the second sealing element (8) is in sealing contact with a second sealing surface (10) on the valve case body (6) forming a second seal, which seals the stilling chamber (3) from the slice chamber (4),

5

wherein in an open state,

a) the first sealing element (7) is at a first distance  $d_1$  from the first sealing surface (9) on the valve case body (6) forming a first clearance and thereby fluidly connecting the stock chamber (2) to the stilling chamber (3) and  
 b) the second sealing element (8) is at a second distance  $d_2$  from the second sealing surface (10) on the valve case body (6) forming a second clearance and thereby fluidly connecting the stilling chamber (3) to the slice chamber (4), and

10

15

wherein when the rotatable valve body (5) is rotated from an open state to the closed state, the first and second sealing elements (7, 8) are simultaneously moved along a circular path into sealing contact with a first and second sealing surface (9, 10)

20

wherein when the rotatable valve body (5) is rotated from an closed state to the open state, the first and second sealing elements (7, 8) are simultaneously moved away along a circular path C from a first and second sealing surface (9, 10),

and wherein

in any open state, the first clearance is larger than the second clearance.

2. The headbox according to claim 1, wherein the first clearance is larger than the second clearance by a factor of more than 1 and up to 3.

25

3. The headbox according to claim 1 or 2, wherein the headbox (1) is rotatable as a whole such as to modify the direction of the stream of the coating composition exiting the slice chamber (4) and/or wherein the headbox (1) is moveable as a whole in one or more directions, preferably at least in a direction perpendicular to the plane of the moving wet pulp substrate, such as to modify the direction of the stream of the coating composition contacting the moving wet pulp substrate in a paper machine, which moving wet pulp substrate is preferably moving in a horizontal direction.

30

4. The headbox according to any preceding claim, wherein the rotatable valve body (5) is a shaft and/or wherein the rotatable valve body (5) is rotatable around a longitudinal axis (A) of the rotatable valve body (5).

35

5. The headbox according to any preceding claim, wherein the rotatable valve body (5) comprises an axle extending along a longitudinal axis (A) of the rotatable valve body (5), which axle is coupled to a controllable rotating driving means, such as to rotate the rotatable valve body (5).

40

6. The headbox according to any preceding claim, wherein the rotatable valve body (5) comprises one or more rods connected via an articulation to a periphery of the rotatable valve body (5), which rod is coupled to a controllable linear driving means, such as to rotate the rotatable valve body (5).

45

7. The headbox according to any preceding claim, wherein the first and/or second sealing elements (7, 8) are formed by sealing ribs, in particular sealing ribs extending, in a preferably rectilinear manner, in parallel to a longitudinal axis (A) of the rotatable valve body (5), said ribs preferably having a rounded, square or pointed tip.

50

8. The headbox according to any preceding claim, wherein in an opened state, the rotatable valve body (5) is at a rotation angle  $\alpha$  of up to  $40^\circ$  and/or in a closed state, the rotatable valve body (5) is at a rotation angle  $\alpha$  of  $0^\circ$ .

9. The headbox according to any preceding claim, wherein the rotatable valve body (5) has a cross-sectional shape that is partially circular, wherein the circular section of the cross-sectional shape of the rotatable valve body (5) is slidingly in sealing contact with one or two gaskets.

55

10. The headbox according to any preceding claim, wherein the rotatable valve body (5) is a shaft and wherein the rotatable valve body (5) is rotatable along a longitudinal axis (A) of the shaft, wherein the first and second sealing elements (7, 8) are located at the same radial distance from the longitudinal axis (A) of the shaft.

11. The headbox according to any preceding claim, wherein the first sealing surface (9) is a convex surface of the valve case body (6), said convex surface having preferably a circular shape, and/or the second sealing surface (10) is a planar surface of the valve case body (6).
- 5 12. The headbox according to any preceding claim, wherein the stilling chamber (3) comprises a concave surface positioned in between the first sealing surface (9) and the second sealing surface (10).
- 10 13. The headbox according to any preceding claim, wherein the clearance formed between the stilling chamber (3) and the slice chamber (4) has the form of a horizontal rectangular slit for ejecting the stream of a coating composition from the slice chamber (4), where the height of the horizontal slit is of from 0.3 to 5 mm, preferably of from 0.8 mm to 3 mm.
- 15 14. The headbox according to any preceding claim, wherein the slice chamber (4) comprises, at its downstream end, a bottom lip (11) for guiding the stream of a coating composition exiting the slice chamber (4), and wherein preferably the bottom lip (11) is a variable length bottom lip (11).
- 20 15. A paper machine comprising a primary headbox for forming a wet pulp substrate and secondary headbox according to any one of claims 1 to 14 for applying a stream of a coating composition onto a moving wet pulp substrate.
- 25 16. A method of applying a stream of a coating composition onto a moving wet pulp substrate in a paper machine, wherein the stream of a coating composition exits the slice chamber (4) of a headbox according to any one claims 1 to 14 in its open state, and wherein the ratio of the speeds of said stream of a coating composition  $V_1$  and moving wet pulp substrate  $V_2$  is between 0.9 and 1.1.
- 30 17. The method of applying a stream of a coating composition onto a moving wet pulp substrate in a paper machine according to claim 16, wherein the stream of a coating composition contacting the moving wet pulp substrate contacts the moving wet pulp substrate at an angle of between 3 and 75°.
- 35 18. The method of applying a stream of a coating composition onto a moving wet pulp substrate in a paper machine according to claim 16 or 17, wherein length of the falling stream of a coating composition is between 3 mm and 500 mm, and/or wherein the flow rate of the stream of a coating composition in the range of 50 till 4000 l/min per meter width of the second clearance.
- 40 19. The method of applying a stream of a coating composition onto a moving wet pulp substrate in a paper machine according to any one claim 16 to 18, wherein the wet pulp substrate has a solids content of less than 20% by weight, or of about 4 to 20%, preferably of about 4 to 8% by weight.
- 45 20. The method of applying a stream of a coating composition onto a moving wet pulp substrate in a paper machine according to any one claim 16 to 19, wherein the coating composition comprises microfibrillated cellulose, preferably is an aqueous suspension of microfibrillated cellulose, and wherein the coating composition more preferably comprises the microfibrillated cellulose in an amount of less than 2.5 weight percent, based on the total weight of the coating composition, more preferably in an amount of from 0.5 to 2.0 weight percent.
- 50 21. Use of a headbox according to any one of claims 1 to 14 in a method of applying a horizontal stream of a coating composition onto a horizontally moving wet pulp substrate in a paper machine, preferably in a method according to any one claims 16 to 20, wherein the horizontal stream of a coating composition exits the slice chamber of the headbox according to any one of claims 1 to 14, in its open state, at a horizontal speed ( $V_1$ ) and wherein the ratio of the horizontal speeds of said horizontal stream of a coating composition and horizontally moving wet pulp substrate ( $V_2$ ) is between 0.9 and 1.1.
- 55

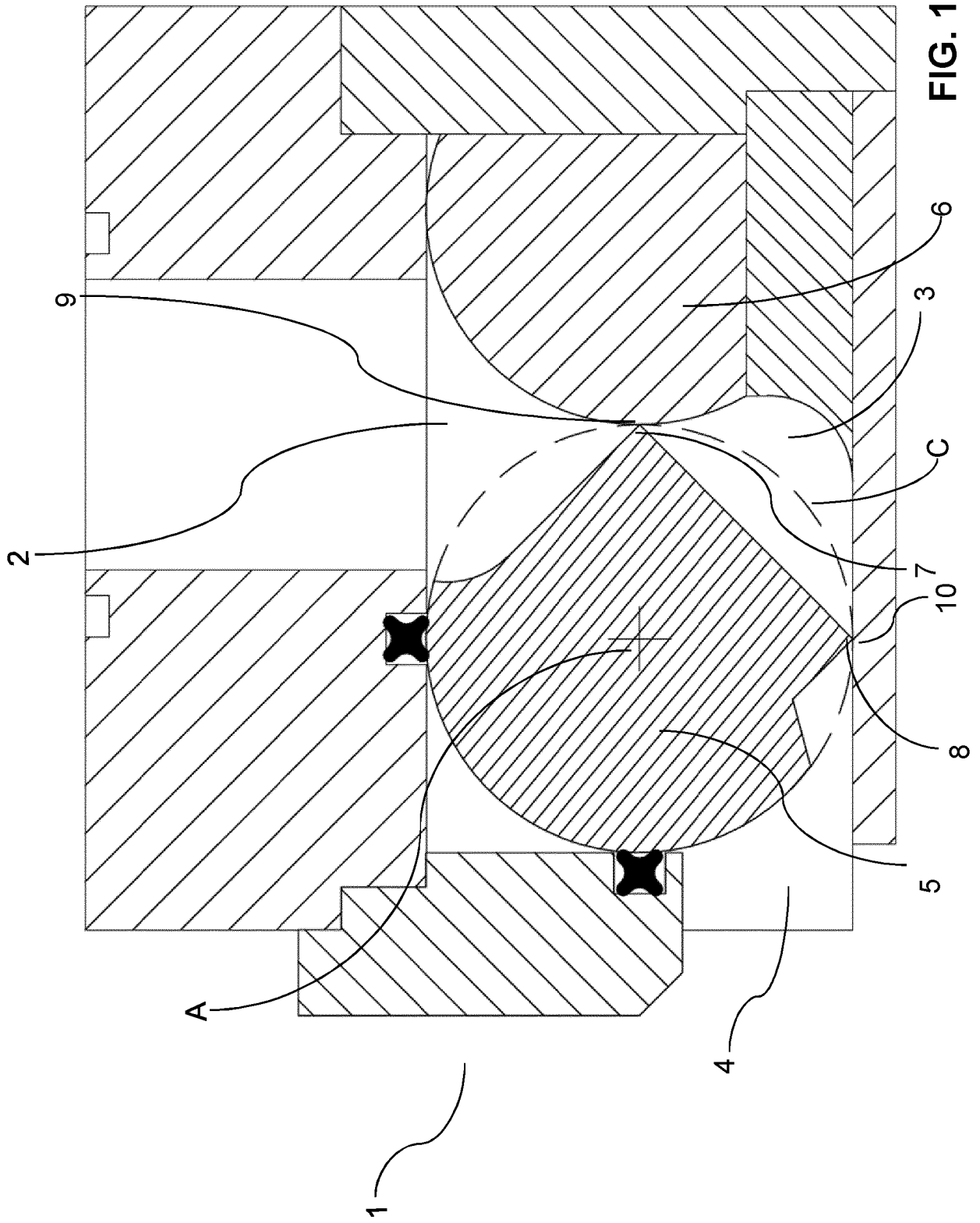



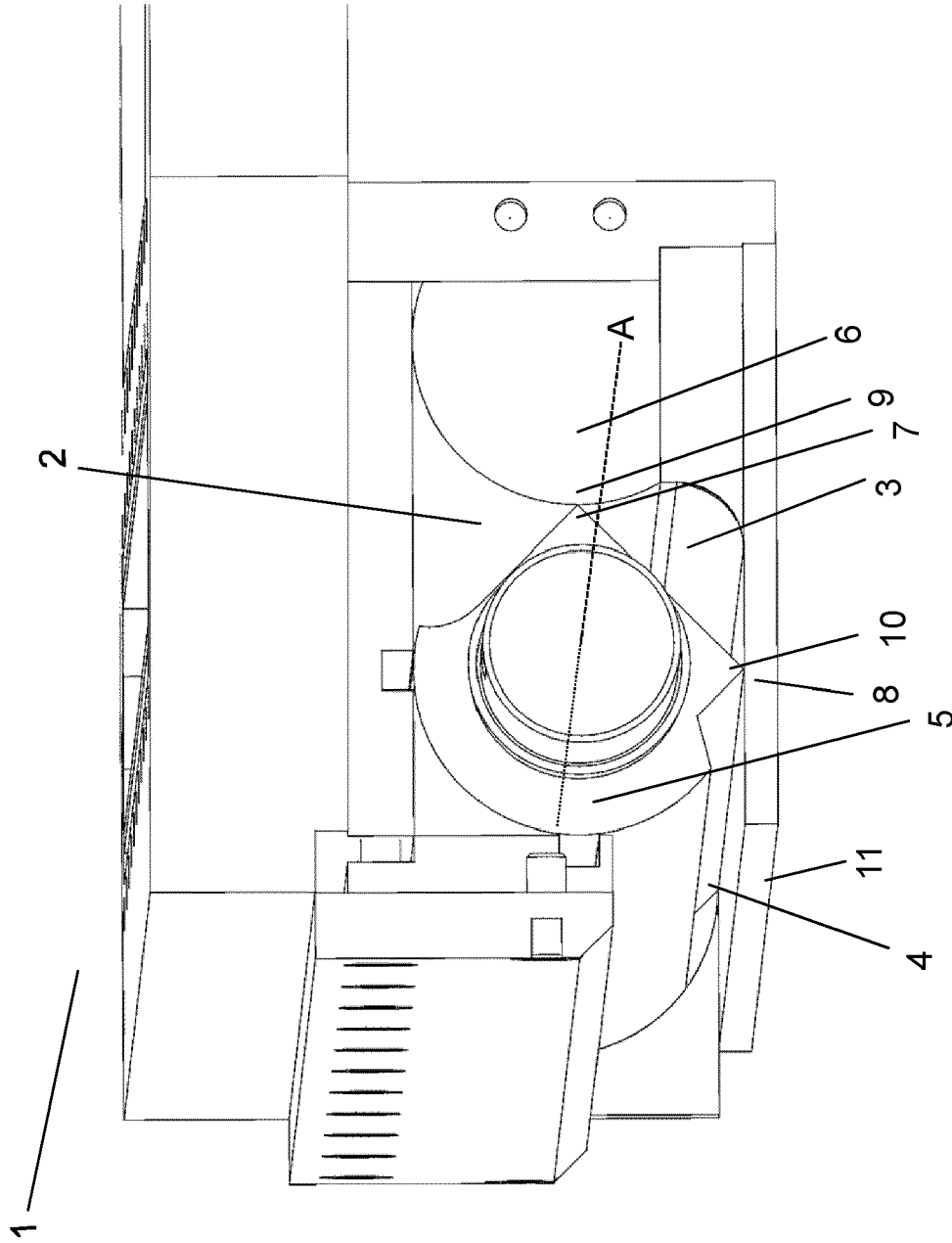

FIG. 3



EUROPEAN SEARCH REPORT

Application Number

EP 22 21 0936

5

10

15

20

25

30

35

40

45

50

55

| DOCUMENTS CONSIDERED TO BE RELEVANT  |  |   |   |
|--|--|---|---|
| Category   | Citation of document with indication, where appropriate, of relevant passages                | Relevant to claim   | CLASSIFICATION OF THE APPLICATION (IPC) |
| A  | US 5 104 011 A (CLARKE-POUNDER IAN J H [US] ET AL) 14 April 1992 (1992-04-14)<br>* figures * | 1-21  | INV.<br>D21F1/02<br>D21H23/24           |
| A  | US 5 456 804 A (LUTHI OSCAR [US])<br>10 October 1995 (1995-10-10)<br>* figures *             | 1-21  |   |
|  |  |   | TECHNICAL FIELDS SEARCHED (IPC)         |
|  |  |   | D21F<br>D21J<br>D21H                    |
| The present search report has been drawn up for all claims   |  |   |   |
| Place of search<br><b>Munich</b>   |  | Date of completion of the search<br><b>24 July 2023</b>   | Examiner<br><b>Kopacz, Ireneusz</b>     |
| CATEGORY OF CITED DOCUMENTS<br>X : particularly relevant if taken alone<br>Y : particularly relevant if combined with another document of the same category<br>A : technological background<br>O : non-written disclosure<br>P : intermediate document |  | T : theory or principle underlying the invention<br>E : earlier patent document, but published on, or after the filing date<br>D : document cited in the application<br>L : document cited for other reasons<br>.....<br>& : member of the same patent family, corresponding document |   |

1  
EPO FORM 1503 03:82 (F04C01)

**ANNEX TO THE EUROPEAN SEARCH REPORT  
ON EUROPEAN PATENT APPLICATION NO.**

EP 22 21 0936

5 This annex lists the patent family members relating to the patent documents cited in the above-mentioned European search report.  
The members are as contained in the European Patent Office EDP file on  
The European Patent Office is in no way liable for these particulars which are merely given for the purpose of information.

24-07-2023

| Patent document cited in search report | Publication date  | Patent family member(s) | Publication date  |
|--|-------------------|-------------------------|-------------------|
| <b>US 5104011 A</b>                    | <b>14-04-1992</b> | <b>AT 400585 B</b>      | <b>25-01-1996</b> |
|  |                   | <b>CA 2047513 A1</b>    | <b>04-02-1992</b> |
|  |                   | <b>FI 913692 A</b>      | <b>04-02-1992</b> |
|  |                   | <b>JP H07324294 A</b>   | <b>12-12-1995</b> |
|  |                   | <b>US 5104011 A</b>     | <b>14-04-1992</b> |
| -----                                  |                   |                         |                   |
| <b>US 5456804 A</b>                    | <b>10-10-1995</b> | <b>AT 406392 B</b>      | <b>25-04-2000</b> |
|  |                   | <b>CA 2198228 A1</b>    | <b>29-02-1996</b> |
|  |                   | <b>FI 970737 A</b>      | <b>18-04-1997</b> |
|  |                   | <b>JP 2838814 B2</b>    | <b>16-12-1998</b> |
|  |                   | <b>JP H09508680 A</b>   | <b>02-09-1997</b> |
|  |                   | <b>US 5456804 A</b>     | <b>10-10-1995</b> |
|  |                   | <b>WO 9606219 A1</b>    | <b>29-02-1996</b> |
| -----                                  |                   |                         |                   |

EPO FORM P0459

For more details about this annex : see Official Journal of the European Patent Office, No. 12/82