



(11) **EP 4 424 200 A1**

(12) **EUROPEAN PATENT APPLICATION**

- (43) Date of publication: **04.09.2024 Bulletin 2024/36**
- (51) International Patent Classification (IPC): **A44B 1/32 (2006.01)**
- (21) Application number: **24160474.3**
- (52) Cooperative Patent Classification (CPC): **A44B 1/32**
- (22) Date of filing: **29.02.2024**

- | | |
|---|--|
| <p>(84) Designated Contracting States:
AL AT BE BG CH CY CZ DE DK EE ES FI FR GB GR HR HU IE IS IT LI LT LU LV MC ME MK MT NL NO PL PT RO RS SE SI SK SM TR
Designated Extension States:
BA
Designated Validation States:
GE KH MA MD TN</p> <p>(30) Priority: 02.03.2023 IT 202300003741
25.01.2024 IT 202400001353</p> | <p>(71) Applicant: Berning Italia S.R.L.
35043 Monselice PD (IT)</p> <p>(72) Inventor: ENNIO, Franco
35043 MONSELICE PD (IT)</p> <p>(74) Representative: Modiano, Micaela Nadia
Modiano & Partners
Via Meravigli, 16
20123 Milano (IT)</p> |
|---|--|

(54) **BUTTON FOR CLOTHING**

- (57) A button (10, 210, 310) for clothing, comprising:
- a mushroom-shaped (11, 211, 311) component;
 - a tack (12, 112, 212, 312) with a head (13, 113, 213, 313) and a shaft (14, 114, 214, 314);
- the button (10, 210, 310) comprises manually removable means for associating the tack (12, 112, 212, 312) with the mushroom-shaped component (11, 211, 311).

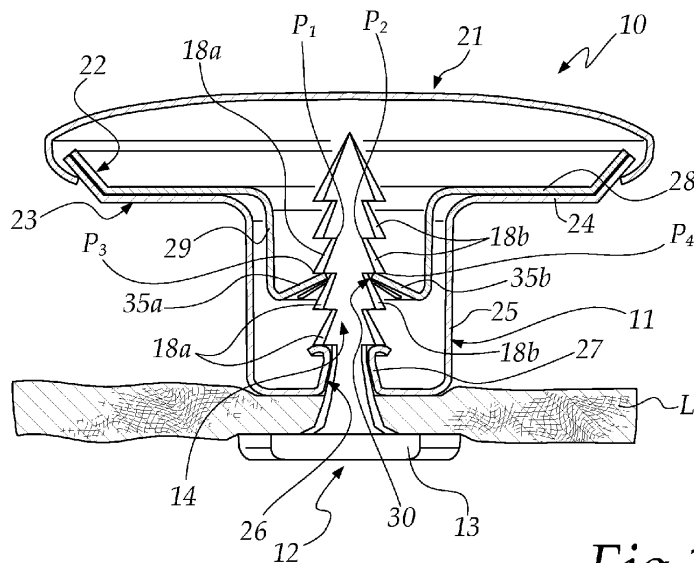

Fig.1

EP 4 424 200 A1

Description

[0001] The present invention relates to a button for clothing.

[0002] The invention can be used in the textile industry for manufacturing items of clothing.

[0003] Nowadays button fastenings are widely used in the textile sector, wherein:

- a button, associated with a first flap of an item of clothing, is inserted into a corresponding buttonhole, in a second flap of the item of clothing, in order to stably associate the two flaps and close the garment,
- or a button made up of two complementary elements, each one arranged on a flap of an item of clothing, which are associated by shape coupling, in order to close the garment.

[0004] Among the various different types of buttons, press-studs are widely used that are made of metal and/or plastic material, and are used in particular on garments made of denim, such as jeans, jackets or shirts.

[0005] The following types of press-studs exist:

- automatic buttons,
- tack buttons.

[0006] Automatic buttons are made up of two complementary elements arranged on two separate flaps of the item of clothing, and can be coupled and decoupled elastically.

[0007] In these buttons, the pressure is exerted between the two complementary elements.

[0008] Tack buttons usually have:

- a mushroom-shaped component, with a tubular shank,
- a tack/rivet with a widened head and a shaft with a cross-section that is substantially comparable to the inner cross-section of the tubular shank.

[0009] In order to fix the button to the flap of the item of clothing, the shaft of the tack is press-fitted into the tubular shank of the mushroom-shaped component, after having been passed through the flap.

[0010] In tack buttons, the pressure is exerted between the tack and the mushroom-shaped component.

[0011] The shaft of the tack/rivet and the shank of the mushroom-shaped component have such shapes and dimensions as to produce a mutual interference after the former is inserted into the latter, generating a stable and non-removable coupling.

[0012] Such prior art has a number of drawbacks.

[0013] In fact, once the garment has reached the end of its life, since the button cannot be removed, the entire garment is usually consigned to the dump together with unsorted refuse, so resulting in a waste in terms of both the materials in the buttons and the materials in the fab-

rics.

[0014] According to an estimate by the Joint Research Center reported in the 2021 document titled "Circular economy perspectives in the EU Textile sector", every year 62% of textile products placed on the market in the EU (European Union) is disposed of as unsorted refuse, and consigned to the dump.

[0015] The European Commission, with Document COM (2022) 141 of 30 March 2022, titled "EU Strategy for Sustainable and Circular Textiles", has established that makers of textile articles and articles of clothing must by 2030 produce articles that are ecologically compatible and sustainable, whereby products will have a value even when they are considered refuse, and therefore can be recycled, and so that fewer textile products will be consigned to the dump.

[0016] This aspect, together with the issues of protecting and safeguarding the environment which nowadays are increasingly a feature of public opinion, determines the need to produce recyclable clothes.

[0017] The need is therefore felt to provide items of clothing in which it is possible to remove press-studs from the fabrics in order to be able to separate the materials and recycle them.

[0018] For example, press-studs are known which have, instead of a tack/rivet, a screw with a threaded shaft which is inserted by pressure, or by screwing, into the shank of the mushroom-shaped component, and can be removed from it by unscrewing it from the mushroom-shaped component.

[0019] Such prior art also has a number of drawbacks, however.

[0020] In fact, in order to be able to remove the screw from the mushroom-shaped component, it is always necessary to use a screwdriver.

[0021] This entails the inconvenience of needing to use a tool, which might not always be to hand.

[0022] Furthermore, with such a button the operation to remove the buttons is long and inconvenient, especially when it is necessary to remove more than one button.

[0023] The aim of the present invention is to provide a button for clothing which is capable of improving the prior art in one or more of the above-mentioned aspects.

[0024] Within this aim, an object of the invention is to provide a button for clothing that can be removed from the item of clothing to which it is applied without the aid of tools.

[0025] Another object of the invention is to provide a button for clothing that can be removed from the item of clothing to which it is applied more easily and rapidly than similar, conventional buttons.

[0026] A further object of the invention is to provide a button for clothing that can be completely and easily recycled.

[0027] Another object of the present invention is to overcome the drawbacks of the prior art in a different manner to any existing solutions.

[0028] Another object of the invention is to provide a button for clothing that is highly reliable, easy to implement and at low cost.

[0029] This aim and these and other objects which will become more apparent hereinafter are achieved by a button for clothing, which comprises:

- a mushroom-shaped component,
- a tack, with a head and a shaft,

characterized in that it comprises manually removable means for associating said tack with said mushroom-shaped component.

[0030] Further characteristics and advantages of the invention will become better apparent from the detailed description that follows of a preferred, but not exclusive, embodiment of the button for clothing according to the invention, which is illustrated for the purposes of non-limiting example in the accompanying drawings wherein:

- Figure 1 is a cross-sectional side view of a button for clothing, according to the invention, in an application of use thereof;
- Figure 2a is a view from above of a first component of the button of Figure 1;
- Figure 2b is a cross-sectional side view of a component of the button of Figure 1;
- Figure 3a is a view from above of a second component of the button of Figure 1;
- Figure 3b is a side view of a component of the button of Figure 1;
- Figures 4a and 4b are two exploded views of the button of Figure 1;
- Figure 5 is a cross-sectional view of a detail of the first component of Figures 2a and 2b;
- Figure 6a is an internal view from above of the button of Figure 1 in a first configuration of use;
- Figure 6b is an internal view from above of the button of Figure 1 in a second configuration of use;
- Figure 7 is an overall view of a different embodiment of a component of the button of Figure 1;
- Figure 8 is a cross-sectional side view of a third embodiment of a button for clothing, according to the invention, in a first configuration thereof;
- Figure 9 is a cross-sectional view of a portion of the button of Figure 8, in a second configuration;
- Figure 10a is a view from above of a first component of the button of Figure 8;
- Figure 10b is a cross-sectional view of the component of Figure 10a;
- Figure 11a is a view from above of a portion of the button of Figure 8;
- Figure 11b is a cross-sectional view of the portion of Figure 11a;
- Figures 12a and 12b are two different side views of a second component of the button of Figure 8;
- Figure 12c is a view from above of the component of Figures 12a and 12b;

- Figure 13 is an exploded view of the button of Figure 8;
- Figure 14 is a cross-sectional side view of a fourth embodiment of a button for clothing, according to the invention, in a first configuration thereof.

[0031] With reference to the figures, a button for clothing, according to the invention, is generally designated by the reference number 10.

[0032] The button 10 comprises:

- a mushroom-shaped component 11,
- a tack 12.

[0033] One of the peculiarities of the invention consists in that it comprises manually removable means for associating the tack 12 with the mushroom-shaped component 11.

[0034] In the present description, the expression "manually removable" means that the tack 12 can be removed from the mushroom-shaped component 11 without the aid of tools.

[0035] The button 10 is a press-button of the "tack" type.

[0036] In the example shown in Figure 1, the button 10 is associated with a flap L of an item of clothing.

[0037] In particular, the tack 12 has a head 13 and a shaft 14.

[0038] The head 13 has two opposing straight edges 15a, 15b.

[0039] One of the peculiarities of the tack 12 consists in that the shaft 14 has:

- two opposing first longitudinal faces 16a, 16b which are at least partially flat, respectively, a first face 16a and a second face 16b,
- two opposing second longitudinal faces 17a, 17b, with a sawtooth profile, respectively a third face 17a and a fourth face 17b,
- an end tip 20, in which all the longitudinal faces 16a, 16b, 17a, 17b converge.

[0040] In the present description, the expression "longitudinal faces" means faces that extend in the longitudinal direction, i.e. the direction of extension of the tack.

[0041] In the present description, the expression "at least partially flat" means that the first longitudinal faces 16a, 16b, are flat for at least one longitudinal portion thereof.

[0042] Each one of the two second longitudinal faces 17a, 17b, is interposed between the two first longitudinal faces 16a, 16b.

[0043] In particular, the third face 17a and the fourth face 17b have a plurality of teeth 18a, 18b, with a transverse edge 19 that is at least partially rounded.

[0044] In the present description, the expression "transverse edge" means the edge lying on a transverse plane, i.e. at right angles to the longitudinal direction and

substantially at right angles to the two first longitudinal faces 16a, 16b.

[0045] In particular, this transverse edge 19 has an at least partially curvilinear profile along its plane of arrangement.

[0046] The teeth 18a of the third face 17a correspond to the teeth 18b of the fourth face 17b.

[0047] The mushroom-shaped component 11 comprises, in the following order:

- a cap 21,
- a coupling element 22 for the tack 12,
- a cap holder element 23 that slopes down in steps or indentations.

[0048] The tack 12 is adapted to be inserted in the mushroom-shaped component 11, by pushing the tip 20 and the shaft 14 inside the cap holder element 23 and the coupling element 22.

[0049] In particular, as better explained below, such means for associating the tack 12 with the mushroom-shaped component 11 comprise the shaft 14 of the tack 12 and the coupling element 22 of the tack 12.

[0050] The cap holder element 23 has:

- a substantially disk-like first portion 24,
- a tubular second portion 25, which extends at right angles to the first portion 24, having an axis of extension that coincides with the axis of the hole F1 of the first portion 24.

[0051] With reference to Figure 1, the second portion 25 has, at the free end, an inlet 26 for inserting the tack 12.

[0052] This inlet 26 is constituted by a tubular third portion 27, which is coaxial to the tubular second portion 25 and inside the latter.

[0053] Specifically the outside diameter of the third portion 27 is smaller than the inside diameter of the second portion 25.

[0054] The third portion 27 is adapted to guide the tack 12 toward the coupling element 22 while keeping it in axial alignment.

[0055] The coupling element 22 of the tack 12 is inserted into the cap holder element 23 and is closed inside the latter by the cap 21.

[0056] The coupling element 22 substantially replicates the internal contouring of the cap holder element 23 and has:

- a substantially disk-like fourth portion 28, directed toward the first portion 24 of the cap holder element 23,
- a tubular fifth portion 29, extending at right angles from the fourth portion 28, having an axis of extension that coincides with the axis of the hole F2 of the substantially disk-like fourth portion 28, such fifth portion 29 being inserted in the second portion 25 of the cap holder element 23.

[0057] The coupling element 22 is provided, at the free end of the fifth portion 29, with a hole 30 for inserting and fastening the tack 12.

[0058] This hole 30 has a substantially rectangular shape, replicating the transverse profile of the shaft 14 of the tack 12, at the transverse edges 19 of two corresponding teeth 18a, 18b, respectively of the third face 17a and of the fourth face 17b.

[0059] In particular, the hole 30 has:

- two opposing and mirror-symmetrical first edges 31a, 31b,
- two opposing and mirror-symmetrical second edges 32a, 32b arranged at a mutual distance that is greater than the mutual distance between the first edges 31a, 31b.

[0060] In particular:

- the first edges 31a, 31b are substantially shaped complementarily to the first longitudinal faces 16a, 16b,
- the second edges 32a, 32b are substantially shaped complementarily to the second longitudinal faces 17a, 17b.

[0061] Advantageously, the mutual distance between the first edges 31a and 31b of the hole 30 is:

- at least slightly smaller than the minimum distance between corresponding points P1, P2 of the second longitudinal faces 17a, 17b of the shaft 14, prior to the insertion of the tack 12 into the coupling element 22, and substantially equal to the minimum distance between corresponding points P1, P2 of the second longitudinal faces 17a, 17b of the shaft 14 after the insertion of the tack 12 into the coupling element 22,
- at least slightly smaller than the maximum distance between corresponding points P3, P4 of the second longitudinal faces 17a, 17b of the shaft 14,
- at least slightly greater than the minimum distance between the first longitudinal faces 16a, 16b of the shaft 14.

[0062] With reference to Figure 1, the minimum distance between corresponding points of the second longitudinal faces 17a, 17b is the minimum distance between a point P1 of the interface region between one tooth 18a of the third face 17a and the next tooth 18a, and the corresponding point P2 of the interface region between one tooth 18b of the fourth face 17b and the next tooth 18b.

[0063] Similarly the maximum distance between corresponding points of the second longitudinal faces 17a, 17b, is the maximum distance between a point P3 on the transverse edge 19 of a tooth 18a of the third face 17a and the corresponding point P4 on the transverse edge 19 of a tooth 18b of the fourth face 17b.

[0064] The hole 30 is substantially defined by the convergence of four slats 35a, 35b, 36a, 36b, which extend at the free end of the fifth portion 29 of the coupling element 22, toward the inside and in a single piece with the fifth portion 29.

[0065] Such slats 35a, 35b, 36a, 36b have a substantially trapezoidal shape with the major base proximate to/at the free end of the fifth portion 29 and the minor base directed toward the cap 21.

[0066] In particular, each one of the first edges 31a, 31b of the hole 30 substantially corresponds to the minor base of a respective first lamina 35a, 35b, and each one of the second edges 32a, 32b of the hole 30 substantially corresponds to the minor base of a respective second lamina 36a, 36b.

[0067] The first slats 35a, 35b are under tension as a consequence of the deformation produced by the insertion of the tack 12 into the coupling element 22.

[0068] Advantageously, the button 10 comprises rotation-preventing/retention means between the coupling element 22 and the cap holder element 23.

[0069] In the example shown in the figures, such rotation-preventing/retention means are constituted by:

- two opposing first flat faces 33a, 33b, of the fifth portion 29 of the coupling element 22, along its perimeter edge,
- two opposing second flat faces 40a, 40b, of the second portion 25 of the cap holder element 23, at and facing toward the first flat faces 33a, 33b.

[0070] In this manner, when the tack 12 is rotated so that it can be removed, as explained below, by means of the shape coupling determined by the first flat faces 33a, 33b facing toward the second flat faces 40a, 40b, the coupling element 22 is prevented from rotating with respect to the cap holder element 23 and it is therefore possible to remove the tack 12.

[0071] In other embodiments, not shown in the figures, the rotation-preventing/retention means between the coupling element 22 and the cap holder element 23 can be implemented differently, for example by means of one or more prominences or protuberances on the first portion 24 of the cap holder element 23 and corresponding and complementarily-shaped indentations on the fourth portion 28 of the coupling element 22.

[0072] The straight edges 15a and 15b of the head 13 of the tack 12 and the first flat faces 33a, 33b of the fifth portion 29 and/or the second flat faces 40a, 40b of the second portion 25 are also adapted to facilitate the orientation of the tack 12 with respect to the coupling element 22 while applying the button 10 to the flap L, and to orient the tack 12 with respect to the coupling element 22 while removing the former from the latter.

[0073] For example, if, as in the embodiment illustrated in the figures, the straight edges 15a, 15b are parallel to the first longitudinal faces 16a, 16b of the shaft 14 of the tack 12, and the first flat faces 33a, 33b of the fifth portion

29 are parallel to the first edges 31a and 31b of the hole 30, then in order to fix the tack 12 to the coupling element 22 it is necessary to orient the straight edges 15a, 15b at right angles to the first flat faces 33a, 33b, as shown in Figure 6a.

[0074] In other embodiments, not shown in the figures, the straight edges of the head of the tack and the first flat faces of the coupling element of the tack can be arranged differently, and the tack and, as a consequence, the coupling element are oriented during the step of fixing the button to the item of clothing.

[0075] Fixing of the tack 12 to the mushroom-shaped component 11 is done by using pressure to insert the shaft 14 of the tack 12 into the cap holder element 23, and simultaneously into the coupling element 22, after having suitably oriented the head 13 and therefore the shaft 14 with respect to the fourth portion 28 of the coupling element 22 using the straight edges 15a, 15b and the first flat faces 33a, 33b, as explained above.

[0076] In this step the particular shape and arrangement of the slats 35a, 35b, 36a, 36b favors the insertion of the tack 12 into the coupling element 22.

[0077] In this manner, when the shaft 14 of the tack 12 is oriented as in Figure 1 and 6a with respect to the coupling element 22, with the first longitudinal faces 16a, 16b arranged at right angles to the first edges 31a, 31b of the hole 30, an interference develops between two opposing and corresponding teeth 18a, 18b and the respective first edges 31a, 31b of the hole 30, producing an interlocking that prevents the mutual sliding between the tack 12 and the mushroom-shaped component 11.

[0078] When it is desired to remove the tack 12 from the mushroom-shaped component 11, it is sufficient to rotate the tack 12 by 90°, orienting the shaft 14 with respect to the coupling element 22 as in Figure 6b, i.e. by arranging the first longitudinal faces 16a, 16b parallel to the first edges 31a, 31b of the hole 30.

[0079] At this point, there is no longer any interference between the teeth 18a, 18b of the tack 12 and the edges of the hole 30, therefore the tack 12 can be easily pulled out from the mushroom-shaped component 11, in so doing removing the button 10 from the item of clothing.

[0080] Advantageously the button 10 is made entirely of metallic material such as stainless steel and/or plastic material such as nylon/polyamide.

[0081] Figure 7 shows another embodiment of the tack, generally designated by the reference number 112.

[0082] In particular, the tack 112 has a head 113 and a shaft 114.

[0083] One of the peculiarities of the tack 112 consists in that the shaft 114 has:

- two opposing first longitudinal faces 116a, 116b which are at least partially flat, respectively, a first face 116a and a second face 116b,
- two opposing second longitudinal faces 117a, 117b having a transverse cross-section shaped like a circular arc, respectively a third face 117a and a fourth

face 117b,

- an end tip 120, in which all the longitudinal faces 116a, 116b, 117a, 117b converge.

[0084] In the present description, the expression "transverse cross-section" means the cross-section lying on a transverse plane, i.e. at right angles to the longitudinal direction and substantially at right angles to the two first longitudinal faces 116a, 116b.

[0085] The use of the tack 112 is similar to the use of the tack 12 explained previously in the first embodiment.

[0086] Similarly to the previous embodiment, also in the second embodiment of the button according to the invention that uses the tack 112:

- the first edges 31a, 31b are substantially shaped complementarily to the first longitudinal faces 116a, 116b,
- the second edges 32a, 32b are substantially shaped complementarily to the second longitudinal faces 117a, 117b.

[0087] In this second embodiment, the mutual distance between the first edges 31a and 31b of the hole 30 is:

- at least slightly smaller than the minimum distance between the second longitudinal faces 117a, 117b of the shaft 114,
- at least slightly greater than the minimum distance between the first longitudinal faces 116a, 116b of the shaft 114.

[0088] In this manner an interference develops between the first edges 31a, 31b of the hole 30 and the second faces 117a, 117b, following the insertion of the tack 112 into the hole 30, as previously described, and it is possible to remove it, after rotating it, by orienting the first faces 116a, 116b with the first edges 31a, 31b.

[0089] With reference to Figures 1 to 7, it should be noted that the means for associating the tack 12, 112 with the mushroom-shaped component 11 comprise the shaft 14, 114 of the tack 12, 112 and the coupling element 22 of the tack 12, 112.

[0090] With reference to Figures 8 to 13, a button for clothing, according to the invention, in a third embodiment thereof, is generally designated by the reference number 210.

[0091] The button 210 comprises:

- a mushroom-shaped component 211,
- a tack 212.

[0092] The button 210 is a press-button of the "tack" type.

[0093] In the example shown in Figures 8 and 9, the button 210 is associated with a flap L' of an item of clothing.

[0094] In particular, the tack 212 has a head 213 and

a shaft 214.

[0095] The head 213 has two opposing straight edges 215a, 215b.

[0096] One of the peculiarities of the tack 212 consists in that the shaft 214 has a widened and flattened end tip 250, with two opposing faces 251a, 251b which are at least partially flat, each one extending on a plane parallel to the plane of arrangement of a respective straight edge 215a, 215b of the head 213.

[0097] In particular, the faces 251a, 251b of the tip 250 have a size, in the direction at right angles to the direction of extension of the shaft 214, that is greater than that of the shaft 214 and/or of its diameter.

[0098] In embodiments not shown in the figures, the tip of the tack is flattened and has a size, in the direction at right angles to the direction of extension of the shaft, that corresponds to that of the shaft and/or of its diameter.

[0099] The mushroom-shaped component 211 comprises, in the following order:

- a cap 221,
- a coupling element 222 for the tack 212,
- a cap holder element 223 that slopes down in steps or indentations.

[0100] The tack 212 is adapted to be inserted in the mushroom-shaped component 211, by pushing the tip 250 and the shaft 214 inside the cap holder element 223 and the coupling element 222.

[0101] In particular, as better explained below, such means for associating the tack 212 with the mushroom-shaped component 211 comprise the shaft 214 and the tip 250 of the tack 212 and the coupling element 222 of the tack 212.

[0102] The cap holder element 223 has:

- a substantially disk-like first portion 224,
- a tubular second portion 225, which extends at right angles to the first portion 224, having an axis of extension that coincides with the axis of the hole F1' of the first portion 224.

[0103] With reference to Figures 8 and 9, the second portion 225 has, at the free end, an inlet 226 for inserting the tack 212.

[0104] This inlet 226 is constituted by a tubular third portion 227, which is coaxial to the tubular second portion 225 and inside the latter.

[0105] Specifically the outside diameter of the third portion 227 is smaller than the inside diameter of the second portion 225.

[0106] The third portion 227 is adapted to guide the tack 212 toward the coupling element 222 while keeping it in axial alignment.

[0107] The coupling element 222 of the tack 212 is inserted into the cap holder element 223 and is closed inside the latter by the cap 221.

[0108] The coupling element 222 substantially repli-

ates the internal contouring of the cap holder element 223 and has:

- a substantially disk-like fourth portion 228, directed toward the first portion 224 of the cap holder element 223,
- a tubular fifth portion 229, extending at right angles from the fourth portion 228, having an axis of extension that coincides with the axis of the hole F2' of the substantially disk-like fourth portion 228, such fifth portion 229 being inserted in the second portion 225 of the cap holder element 223.

[0109] The coupling element 222 is provided, at the free end of the fifth portion 229, with a hole 230 for inserting the tack 212.

[0110] This coupling element 222 has a lamina 260 for the abutment/interlocking of the tip 250 of the tack 212, which has a slit 261 passing through its thickness, and is provided with a widened central portion 262.

[0111] In particular, the widened central portion 262 has a circular profile with:

- a diameter smaller than the dimension of the faces 251a, 251b of the tip 250 of the tack 212, in the direction at right angles to the direction of extension of the shaft 214,
- an axis coinciding with the axis of the hole F2' of the fourth portion 228.

[0112] In this manner, in the coupled configuration, shown in Figure 8, an interference/interlocking develops between the edge of the central portion 262 and the tip 250 of the tack 212.

[0113] The slit 261 is defined by two opposing flaps 266a, 266b, which are arranged, at least proximate to the central portion 262, at a mutual distance at least slightly greater than the distance between the faces 251a, 251b of the tip 250 of the tack 212.

[0114] In this manner, in the uncoupled configuration, shown in Figure 9, when the faces 251a, 251b of the tip 250 are substantially parallel to the flaps 266a, 266b, no interlocking/interference develops between the tack 212 and the coupling element 222 and it is possible to remove the tack 212.

[0115] In the embodiment shown in the figures, the lamina 260 is separated from the fourth portion 228 and is inserted into a seat 263 of the fourth portion 228, arranged on the face of the fourth element 228 located opposite to the face from which the fifth portion 229 extends.

[0116] In other embodiments, not shown in the figures, the lamina 260 is in a single piece with the fourth portion 228.

[0117] In particular, the lamina 260 has an at least partially circular profile with a straight section 264 adapted to come into abutment against a straight edge 265 of the seat 263 of the fourth portion 228, in order to prevent the

rotation of the lamina 260.

[0118] Advantageously, the button 210 comprises rotation-preventing/retention means between the coupling element 222 and the cap holder element 223.

[0119] In the embodiment shown in the figures, such rotation-preventing/retention means are constituted by:

- two opposing first flat faces 233a, 233b of the fifth portion 229 of the coupling element 222, along its perimeter edge,
- two opposing second flat faces 240a, 240b of the second portion 225 of the cap holder element 223, at and facing toward the first flat faces 233a, 233b.

[0120] In this manner, when the tack 212 is rotated so that it can be removed, as explained below, by means of the shape coupling determined by the first flat faces 233a, 233b facing toward the second flat faces 240a, 240b, the coupling element 222 is prevented from rotating with respect to the cap holder element 223 and it is therefore possible to remove the tack 212.

[0121] In other embodiments, not shown in the figures, the rotation-preventing/retention means between the coupling element 222 and the cap holder element 223 can be implemented differently, for example by means of one or more prominences or protuberances on the first portion 224 of the cap holder element 223 and corresponding and complementarily-shaped indentations on the fourth portion 228 of the coupling element 222.

[0122] The straight edges 215a and 215b of the head 213 of the tack 212 and the first flat faces 233a, 233b of the fifth portion 229 and/or the second flat faces 240a, 240b of the second portion 225 are also adapted to facilitate the orientation of the tack 212 with respect to the coupling element 222, in the step of applying the button 210 to the flap L', and to orient the tack 212 with respect to the coupling element 222 in the step of removing the former from the latter.

[0123] For example, if, as in the embodiment illustrated in the figures, the straight edges 215a, 215b of the head 213 of the tack 212 are parallel to the faces 251a, 251b of the tip 250 of the tack 212, and the first flat faces 233a, 233b of the fifth portion 229 are parallel to the flaps 266a, 266b that define the slit 261, then in order to fix the tack 212 to the coupling element 222 it is necessary to orient the straight edges 215a, 215b at right angles to the first flat faces 233a, 233b.

[0124] In other embodiments, not shown in the figures, the straight edges of the head of the tack and the faces of the tip of the tack can be arranged differently, and the tack and, as a consequence, the coupling element are oriented during the step of fixing the button to the item of clothing.

[0125] Fixing of the tack 212 to the mushroom-shaped component 211 is done by using pressure to insert the shaft 214 of the tack 212 into the cap holder element 223, and simultaneously into the coupling element 222, after having suitably oriented the head 213 and therefore the

shaft 214 of the tack 212 with respect to the fourth portion 228 of the coupling element 222 using the straight edges 215a, 215b and the first flat faces 233a, 233b, as explained above.

[0126] In this step the particular shape and arrangement of the central portion 262 favors the insertion of the tack 212 into the coupling element 222.

[0127] In this manner, when the shaft 214 of the tack 212 is oriented as in Figure 8 with respect to the coupling element 222, with the faces 251a, 251b of the tip 250 of the tack 212 arranged at right angles to the flaps 266a, 266b that define the slit 261, an interference develops between the tip 250 of the tack 212 and the edges of the central portion 262, producing an interlocking that prevents the mutual sliding between the tack 212 and the mushroom-shaped component 211.

[0128] When it is desired to remove the tack 212 from the mushroom-shaped component 211, it is sufficient to rotate the tack 212 by 90°, orienting the shaft 214 with respect to the coupling element 222 as in Figure 9, i.e. by arranging the faces 251a, 251b of the tip 250 parallel to the flaps 266a, 266b that define the slit 261.

[0129] At this point, there is no longer any interference between the tip 250 of the tack 212 and the flaps 266a, 266b, therefore the tack 212 can be easily pulled out from the mushroom-shaped component 211, in so doing removing the button 210 from the item of clothing.

[0130] Figure 14 is a cross-sectional side view of a button according to the invention in a fourth embodiment.

[0131] With reference to Figure 14, the button for clothing according to the invention is generally designated by the reference number 310 and all the components that are analogous to those of the third embodiment have been given the same reference numbers, increased by 100.

[0132] Differently from the first embodiment illustrated previously, in the fourth embodiment the mushroom-shaped component 311 comprises in the following order:

- a cap 321,
- a coupling element 322 for the tack 312, which also acts as the cap holder element.

[0133] Basically, in this embodiment there is no cap holder element separate from the coupling element; rather, the cap 321 is closed directly on the coupling element 322.

[0134] In this manner the button 310 is simpler in terms of construction and more straightforward to manufacture.

[0135] The tack 312 is adapted to be inserted in the mushroom-shaped component 311, by pushing the tip 350 and the shaft 314 directly inside the coupling element 322.

[0136] The fixing of the tack 312 to the mushroom-shaped component 311 is done by using pressure to insert the shaft 314 of the tack 312 into the coupling element 322, after having suitably oriented the head 313 and therefore the shaft 314 of the tack 312 with respect to

the fourth portion 328 of the coupling element 322 using the straight edges 315a, 315b and the first flat faces 333a, 333b of the fifth portion 329.

[0137] In this step the particular shape and arrangement of the central portion 362 favors the insertion of the tack 312 into the coupling element 322.

[0138] In this manner, when the shaft 314 of the tack 312 is oriented as in Figure 14 with respect to the coupling element 322, with the faces 351a, 351b of the tip 350 of the tack 312 arranged at right angles to the flaps (of which only the flap 366b is shown) that define the slit 361, an interference develops between the tip 350 of the tack 312 and the edges of the central portion 362, producing an interlocking that prevents the mutual sliding between the tack 312 and the mushroom-shaped component 311.

[0139] When it is desired to remove the tack 312 from the mushroom-shaped component 311, it is sufficient to rotate the tack 312 by 90°, i.e. by arranging the faces 351a, 351b of the tip 350 parallel to the flaps that define the slit 361.

[0140] At this point, there is no longer any interference between the tip 350 of the tack 312 and the flaps of the slit 361, therefore the tack 312 can be easily pulled out from the mushroom-shaped component 311, in so doing removing the button 310 from the item of clothing.

[0141] Advantageously the button 210, 310 is made entirely of metallic material such as for example stainless steel and/or plastic material such as nylon/polyamide.

[0142] With reference to Figures 8 to 14, it should be noted that the means for associating the tack 212, 312 with the mushroom-shaped component 211, 311 comprise the tip 250, 350 of the tack 212, 312 and the coupling element 222, 322 of the tack 212, 312.

[0143] It should be noted that the straight edges 15a, 15b, 215a, 215b, 315a, 315b of the head 13, 113, 213, 313 of the tack 12, 112, 212, 312 allow the removal of the tack 12, 112, 212, 312 from the mushroom-shaped component 11, 211, 311 manually, and without the need to use tools.

[0144] In practice it has been found that the invention fully achieves the intended aim and objects by providing a button for clothing that can be removed from the item of clothing to which it is applied without the aid of tools.

[0145] Furthermore, according to the invention a button for clothing has been devised that can be removed from the item of clothing to which it is applied more easily and rapidly than similar, conventional buttons.

[0146] In addition, according to the invention a button for clothing has been provided that can be completely and easily recycled.

[0147] The invention thus conceived is susceptible of numerous modifications and variations, all of which are within the scope of the appended claims. Moreover, all the details may be substituted by other, technically equivalent elements.

[0148] In practice the materials employed, provided they are compatible with the specific use, and the contingent dimensions and shapes, may be any according

to requirements and to the state of the art.

[0149] The disclosures in Italian Patent Applications No. 102023000003741 and No. 102024000001353 from which this application claims priority are incorporated herein by reference.

[0150] Where technical features mentioned in any claim are followed by reference signs, such reference signs have been inserted for the sole purpose of increasing the intelligibility of the claims and accordingly such reference signs do not have any limiting effect on the interpretation of each element identified by way of example by such reference signs.

Claims

1. A button (10, 210, 310) for clothing, comprising:

- a mushroom-shaped component (11, 211, 311),
- a tack (12, 112, 212, 312), with a head (13, 113, 213, 313) and a shaft (14, 114, 214, 314),

characterized in that it comprises manually removable means for associating said tack (12, 112, 212, 312) with said mushroom-shaped component (11, 211, 311).

2. The button (10, 210, 310) according to claim 1, **characterized in that** said head (13, 113, 213, 313) has two opposing straight edges (15a, 15b, 215a, 215b, 315a, 315b).

3. The button (10, 210, 310) according to claim 1, **characterized in that** said mushroom-shaped component (11, 211, 311) comprises, in the following order:

- a cap (21, 221, 321),
- a coupling element (22, 222, 322) for said tack (12, 112, 212, 312).

4. The button (10, 210, 310) according to one or more of the preceding claims, **characterized in that** said coupling element (22, 222, 322) of said tack (12, 112, 212, 312) has:

- a substantially disk-like fourth portion (28, 228, 328),
- a tubular fifth portion (29, 229, 329), which extends at right angles to said fourth portion (28, 228, 328), having an axis of extension that coincides with the axis of the hole (F2, F2') of said fourth portion (28, 228, 328), said coupling element (22, 222, 322) having, at the free end of said fifth portion (29, 229, 329), a hole (30, 230, 330) for the insertion of said tack (12, 112, 212, 312).

5. The button (10) according to claim 1, **characterized in that** said shaft (14, 114) of said tack (12, 112) has:

- two opposing first longitudinal faces (16a, 16b, 116a, 116b) which are at least partially flat, respectively, a first face (16a, 116a) and a second face (16b, 116b),
- two opposing second longitudinal faces (17a, 17b, 117a, 117b), respectively, a third face (17a, 117a) and a fourth face (17b, 117b), respectively,
- an end tip (20, 120) in which said first longitudinal faces (16a, 16b, 116a, 116b) and said second longitudinal faces (17a, 17b, 117a, 117b) converge.

6. The button (10) according to one or more of the preceding claims, **characterized in that** it comprises a cap holder element (23), said cap holder element (23) having:

- a substantially disk-like first portion (24),
- a tubular second portion (25), which extends at right angles to said first portion (24), having an axis of extension that coincides with the axis of the hole (F1) of said first portion (24), said second portion (25) having an inlet (26) at its free end for the insertion of said tack (12).

7. The button (10) according to one or more of the preceding claims, **characterized in that** said inlet (26) is constituted by a tubular third portion (27), which is coaxial to said second portion (25) and internal to it, the outside diameter of said third portion (27) being smaller than the inside diameter of said second portion (25).

8. The button (10) according to one or more of the preceding claims, **characterized in that** said hole (30) of said fifth portion (29) has a substantially rectangular contour which replicates the transverse profile of said shaft (14, 114) of said tack (12, 112).

9. The button (10) according to one or more of the preceding claims, **characterized in that** said hole (30) has:

- two opposing and mirror-symmetrical first edges (31a, 31b),
- two opposing and mirror-symmetrical second edges (32a, 32b) arranged at a mutual distance that is greater than the mutual distance between said first edges (31a, 31b).

10. The button (10) according to one or more of the preceding claims, **characterized in that:**

- said first edges (31a, 31b) are substantially

shaped complementarily to said first longitudinal faces (16a, 16b, 116a, 116b) of said shaft (14), - said second edges (32a, 32b) are substantially shaped complementarily to said second longitudinal faces (17a, 17b, 117a, 117b).

11. The button (10) according to one or more of the preceding claims, **characterized in that** said third face (17a) and said fourth face (17b) have a sawtooth profile and a plurality of teeth (18a, 18b) with a transverse edge (19) that is at least partially rounded.

12. The button (10) according to one or more of the preceding claims, **characterized in that** the mutual distance between said first edges (31a, 31b) of said hole (30) is:

- at least slightly smaller than the minimum distance between corresponding points (P1, P2) of said second longitudinal faces (17a, 17b) of said shaft (14), prior to the insertion of said tack (12) into said coupling element (22), and substantially equal to the minimum distance between corresponding points (P1, P2) of said second longitudinal faces (17a, 17b) of said shaft (14) after the insertion of said tack (12) into said coupling element (22),

- at least slightly smaller than the maximum distance between corresponding points (P3, P4) of said second longitudinal faces (17a, 17b) of said shaft (14),

- at least slightly greater than the minimum distance between said first longitudinal faces (16a, 16b) of said shaft (14).

13. The button (10) according to one or more of claims 1 to 10, **characterized in that** said third face (117a) and said fourth face (117b) have a transverse cross-section shaped like a circular arc.

14. The button (10) according to claim 13, **characterized in that** the mutual distance between said first edges (31a, 31b) of said hole (30) is:

- at least slightly smaller than the minimum distance between said second longitudinal faces (117a, 117b) of said shaft (114),

- at least slightly greater than the minimum distance between said first longitudinal faces (116a, 116b) of said shaft (114).

15. The button (10) according to one or more of the preceding claims, **characterized in that** it comprises rotation-preventing/retention means (33a, 33b, 40a, 40b) between said coupling element (22) and said cap holder element (23).

16. The button (210, 310) according to any one of claims

1 to 4, **characterized in that** said shaft (214, 314) has a flattened end tip (250, 350), said tip (250, 350) having two opposing and at least partially flat faces (251a, 251b, 351a, 351b), each one of said faces (251a, 251b, 351a, 351b) extending on a plane parallel to the plane of arrangement of a respective one of said straight edges (215a, 215b, 315a, 315b) of said head (213, 313).

17. The button (210, 310) according to claim 16, **characterized in that** said coupling element (222, 322) has a lamina (260, 360) for the abutment/interlocking of said tip (250, 350) of said tack (212, 312), said lamina (260, 360) having a slit (261, 361) passing through its thickness, said slit (261, 361) being provided with a widened central portion (262, 362), said central portion (262, 362) having a circular profile with:

- a diameter smaller than the dimension of said faces (251a, 251b, 351a, 351b), of said tip (250, 350) of said tack (212, 312), in the direction at right angles to the direction of extension of said shaft (214, 314),

- an axis coinciding with the axis of the hole (F2') of said fourth portion (228, 328).

18. The button (210, 310), according to claim 17, **characterized in that** said slit (261, 361) is defined by two opposite flaps (266a, 266b, 366b) which are arranged, at least proximate to said central portion (262, 362), at a mutual distance at least slightly greater than the distance between said faces (251a, 251b, 351a, 351b) of said tip (250, 350) of said tack (212, 312).

19. The button (210, 310), according to claim 17 or 18, **characterized in that** said lamina (260, 360) is inserted in a seat (263) of said fourth portion (228, 328), and has an at least partially circular profile with a straight section (264) that is adapted to come into abutment against a straight edge (265) of said seat (263) of said fourth portion (228).

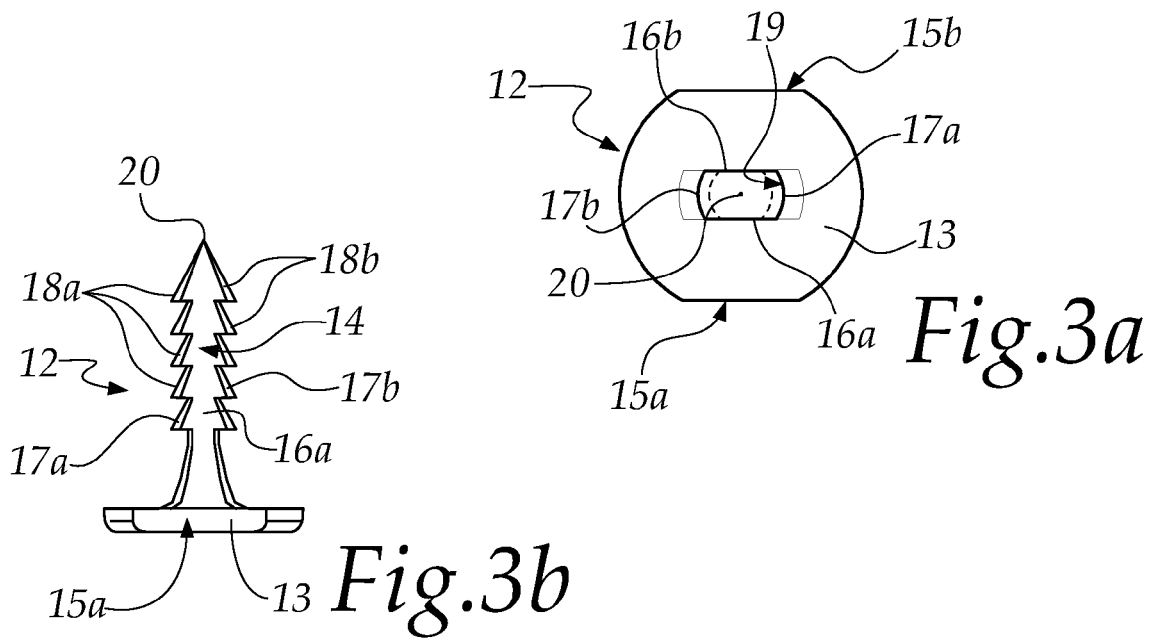
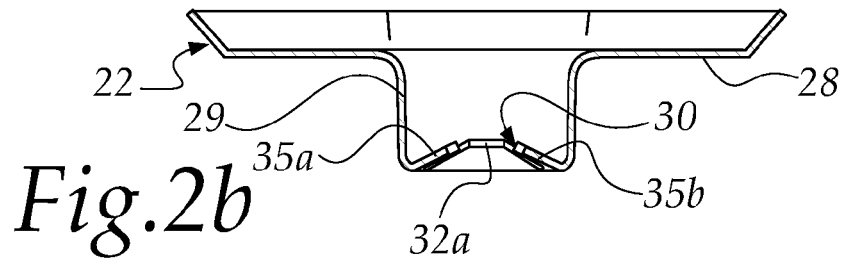
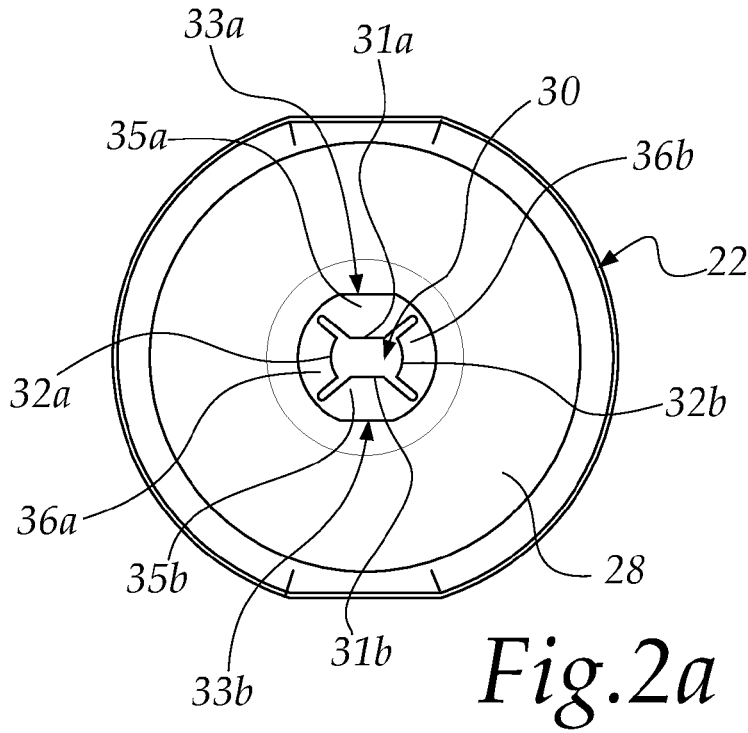

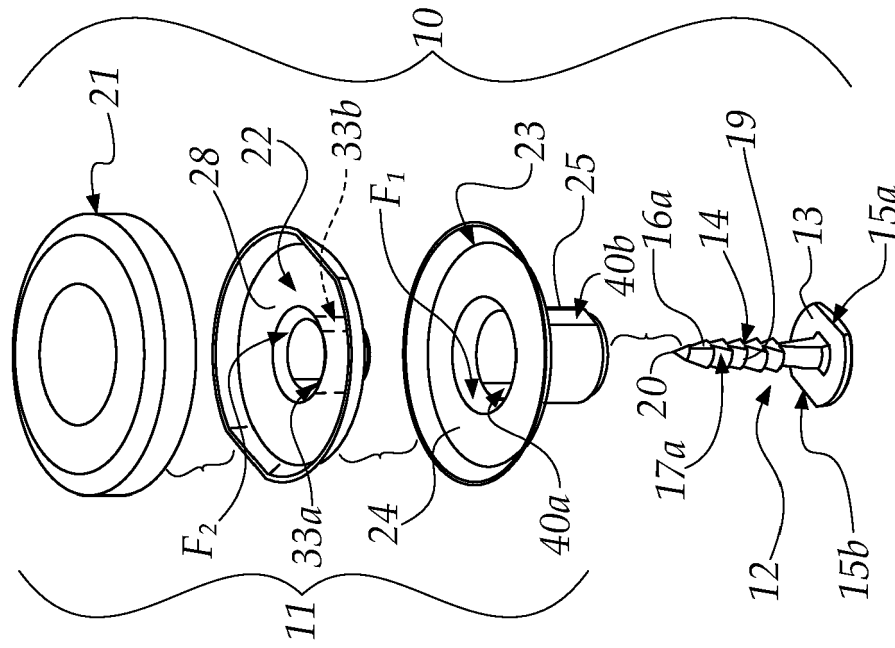

Fig. 4b

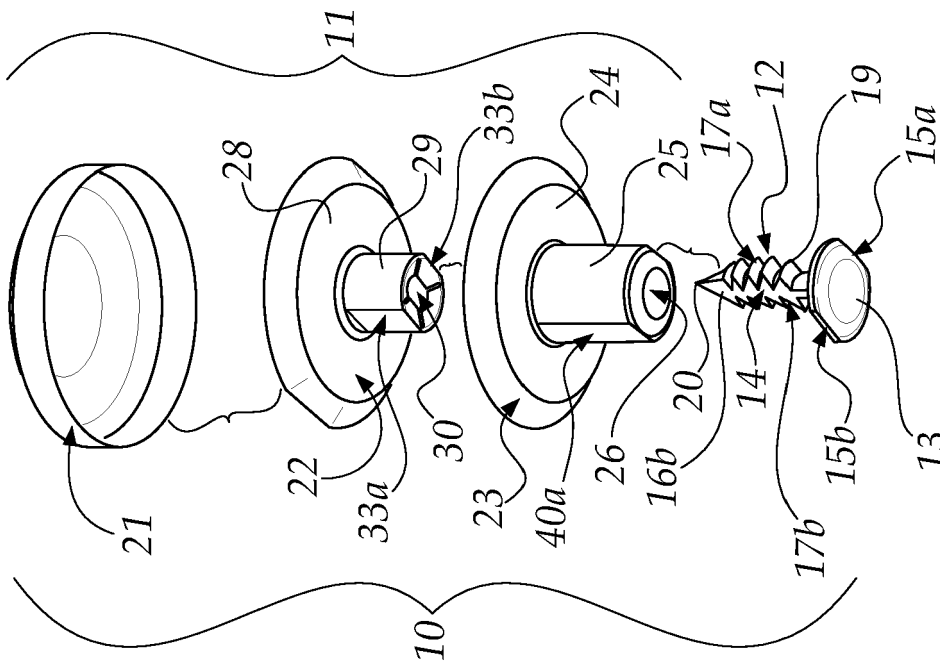

Fig. 4a

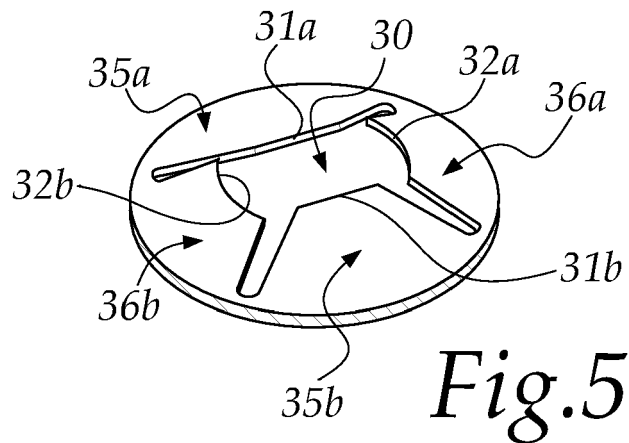

Fig. 5

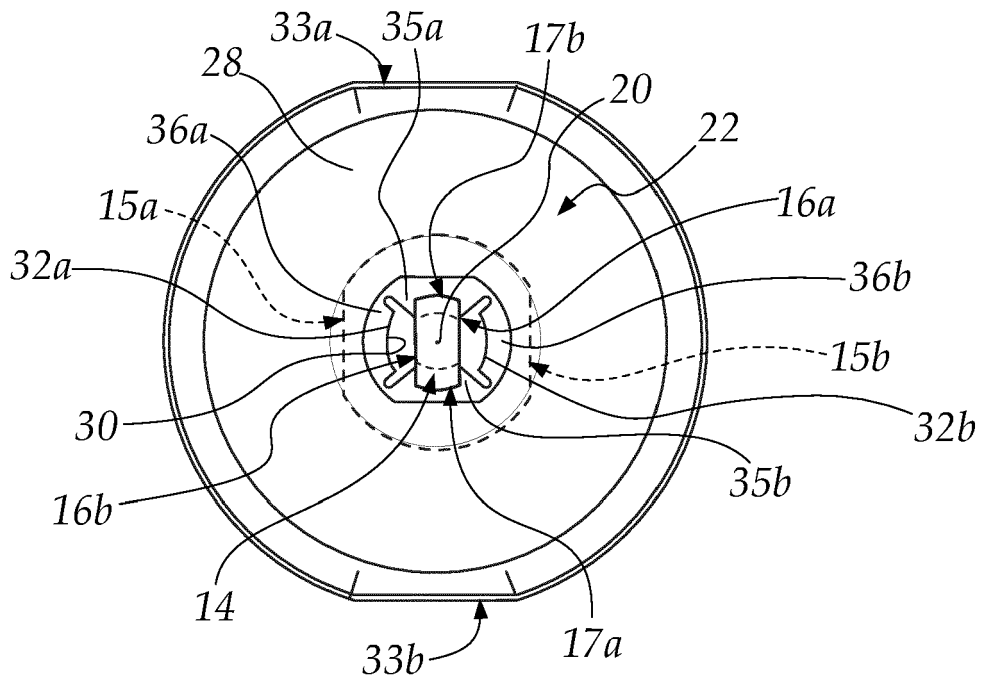

Fig. 6a

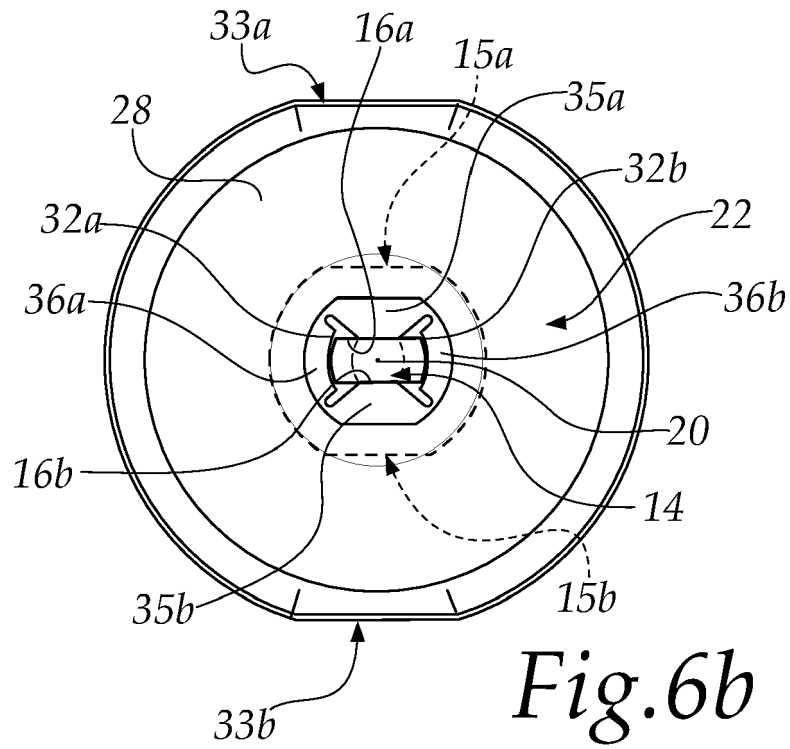

Fig. 6b

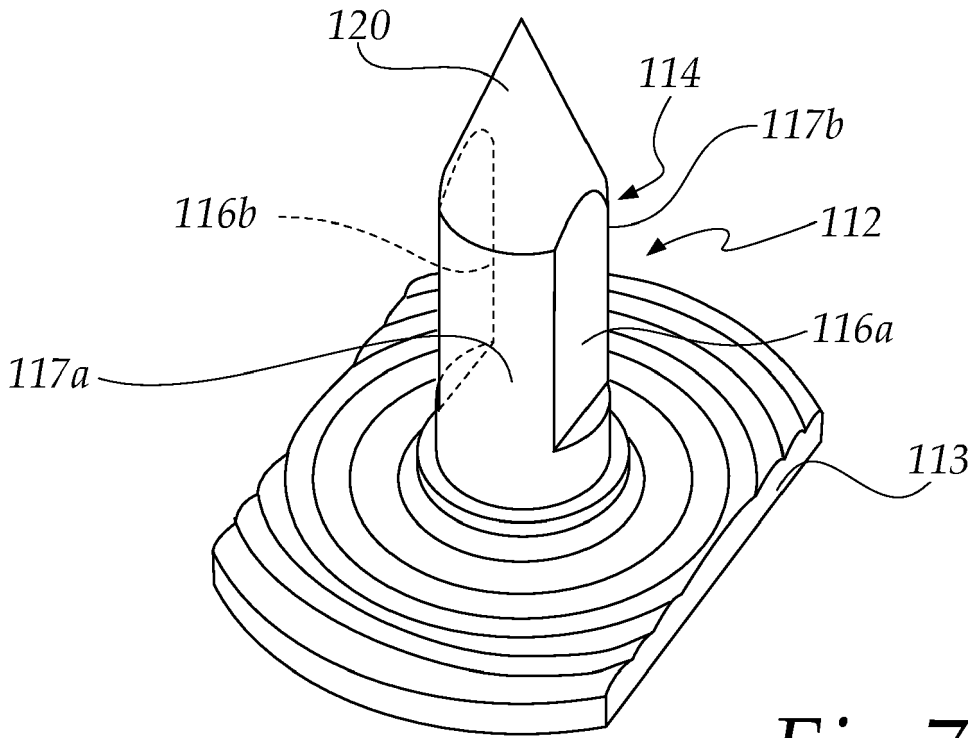

Fig. 7

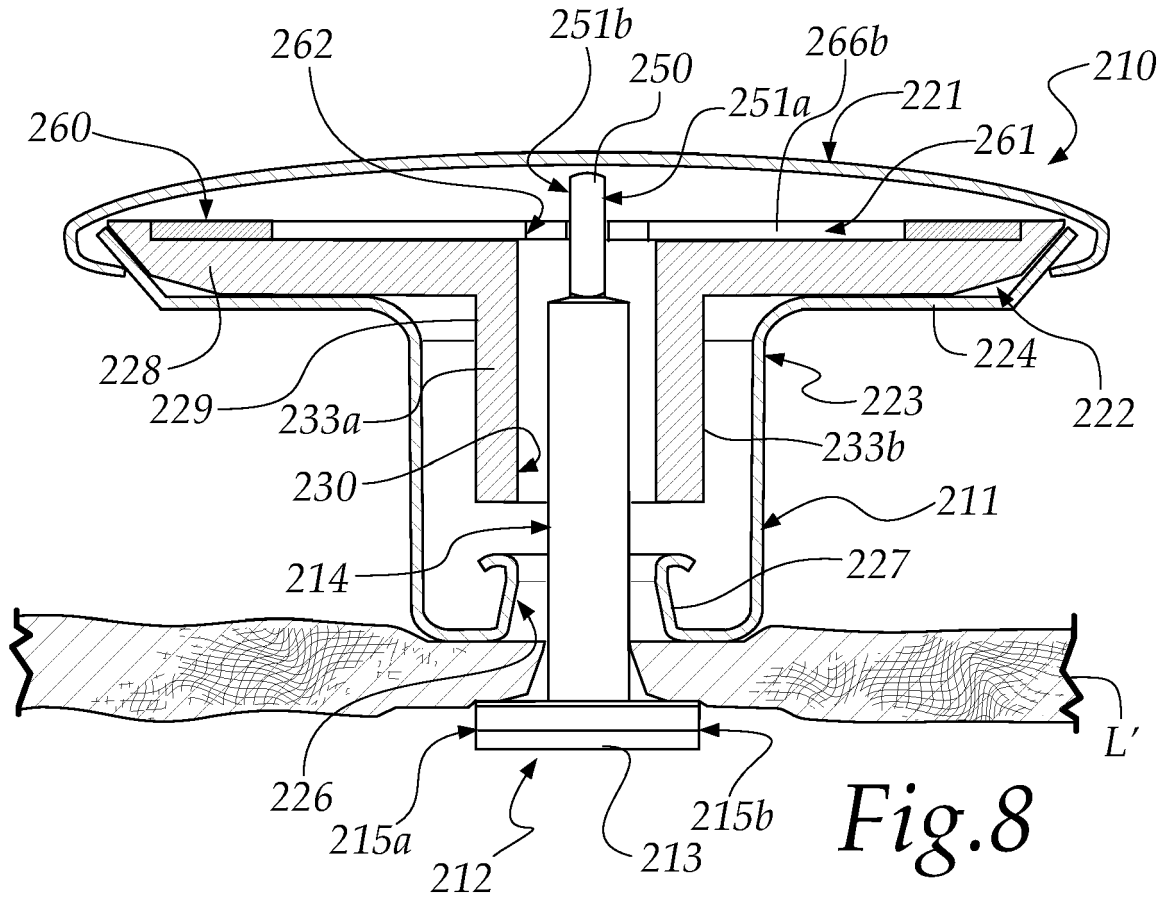

Fig. 8

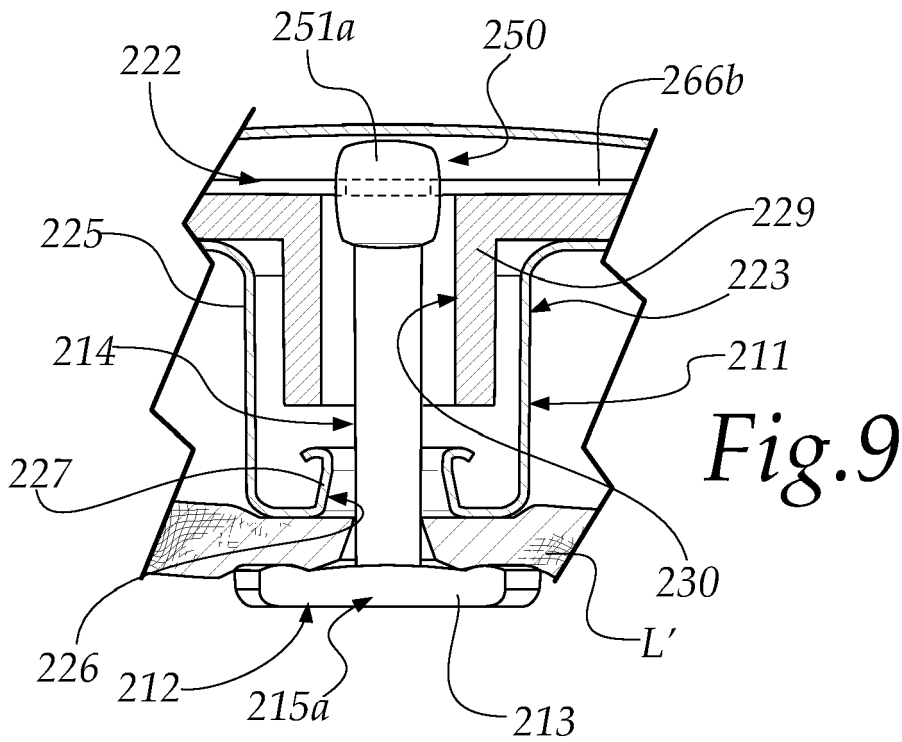

Fig. 9

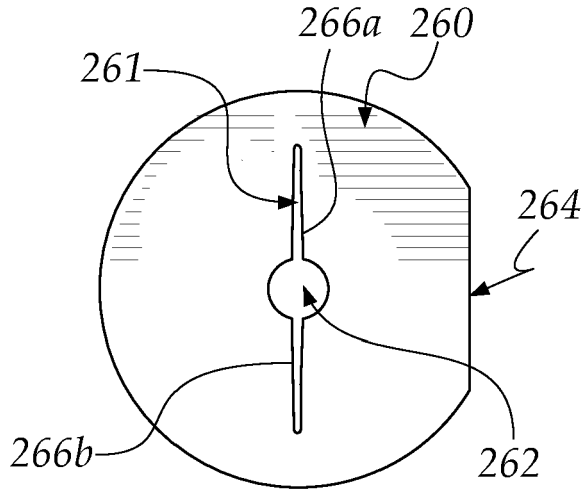

Fig. 10a

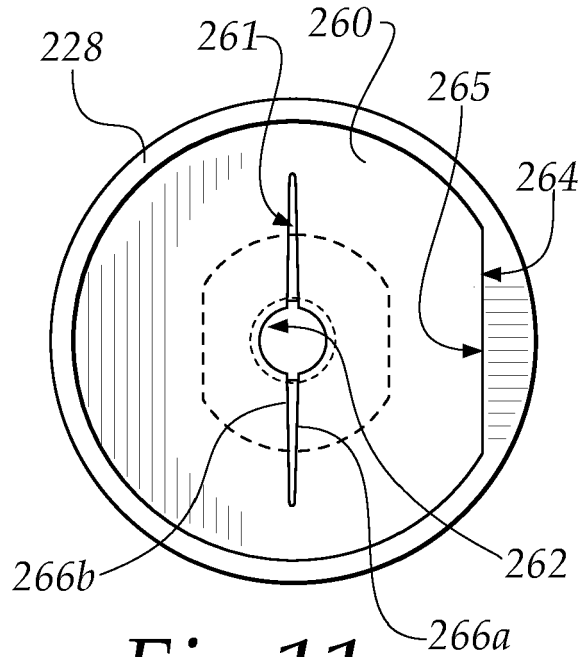

Fig. 11a

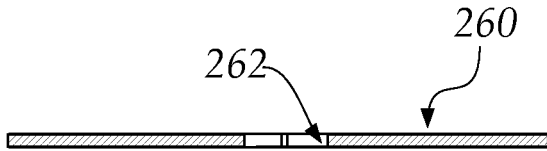

Fig. 10b

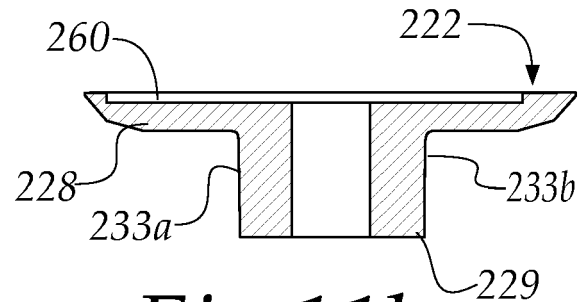

Fig. 11b

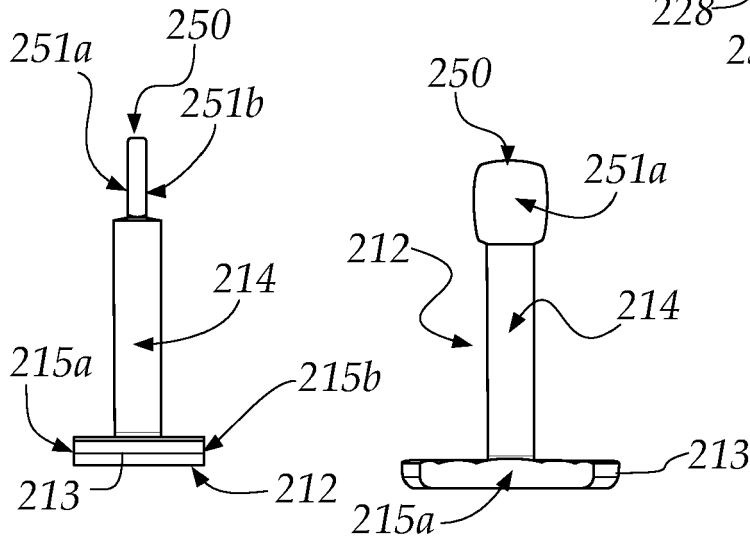

Fig. 12a

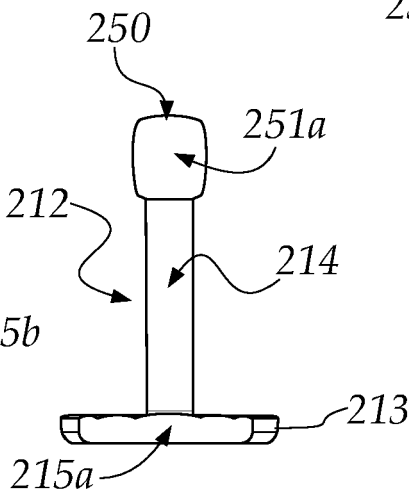

Fig. 12b

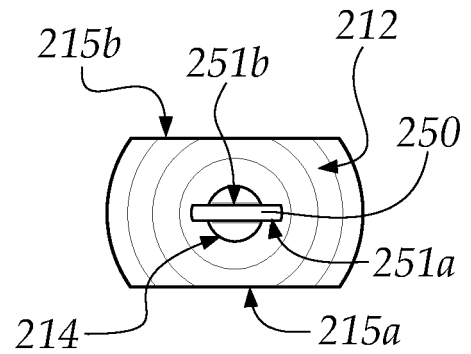

Fig. 12c

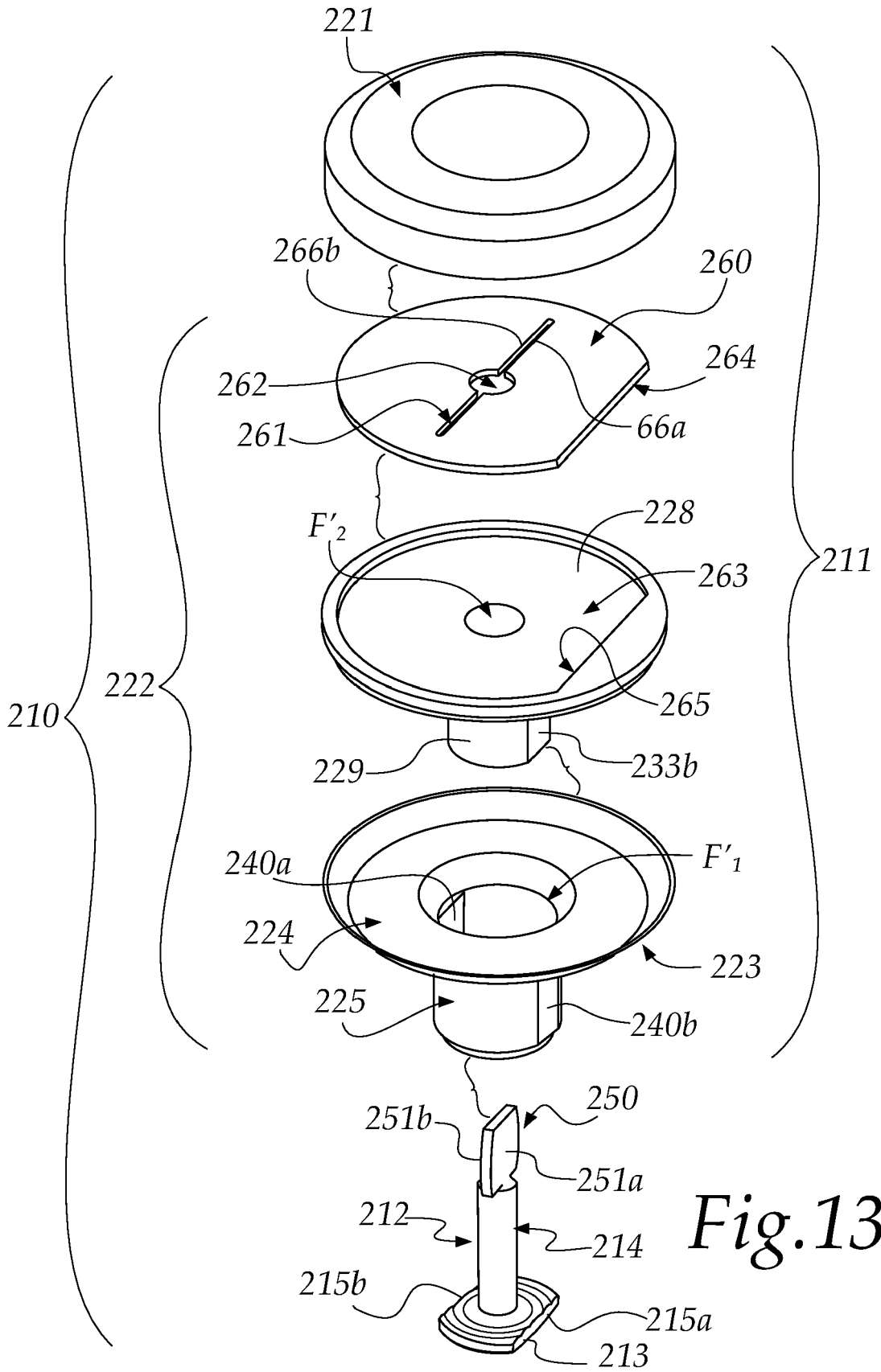

Fig.13

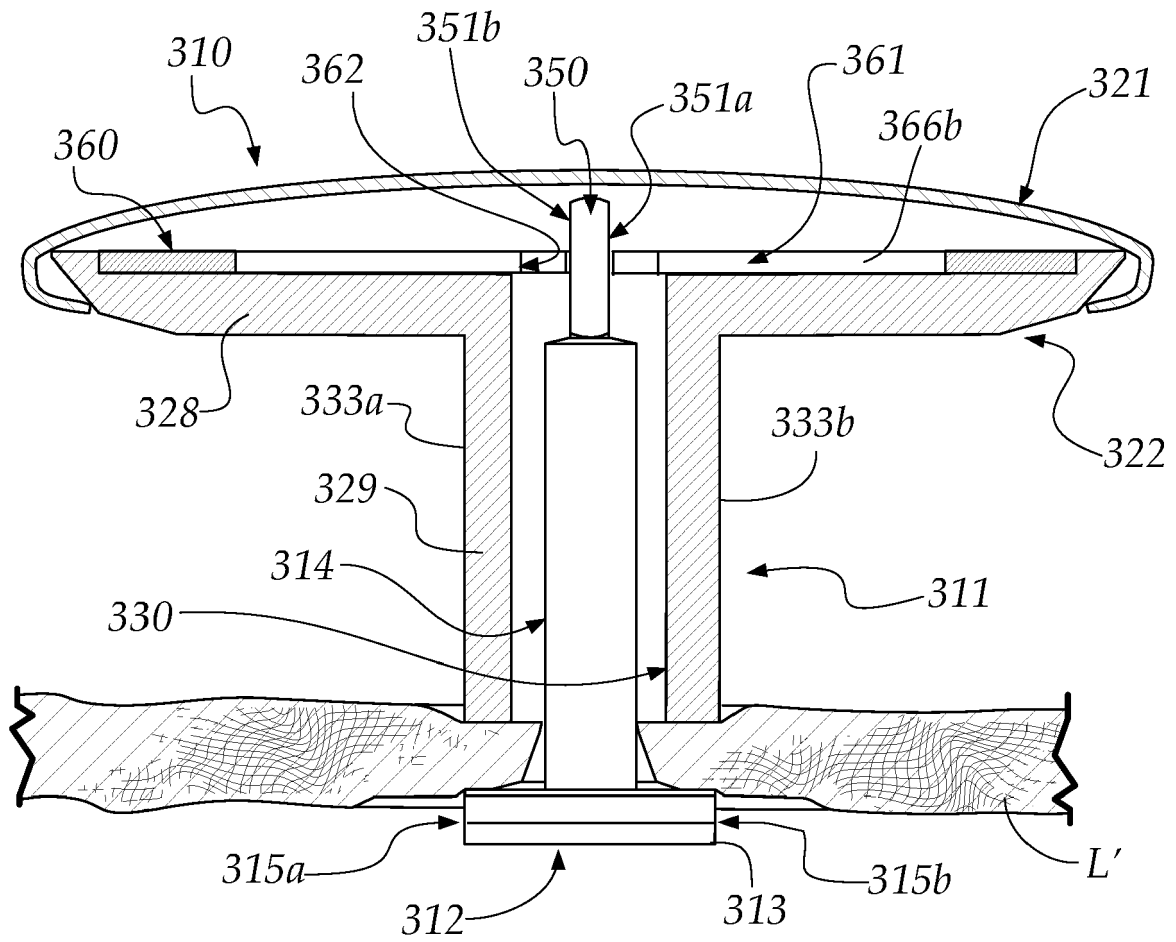

Fig.14



EUROPEAN SEARCH REPORT

Application Number

EP 24 16 0474

5

10

15

20

25

30

35

40

45

50

55

DOCUMENTS CONSIDERED TO BE RELEVANT			
Category	Citation of document with indication, where appropriate, of relevant passages	Relevant to claim	CLASSIFICATION OF THE APPLICATION (IPC)
X	DE 555 264 C (KARL HOLLERER; ADOLF KADLETZ) 20 July 1932 (1932-07-20) * page 1, column 1, line 40 - line 62; figures 1,2 *	1-11,13, 15-19	INV. A44B1/32
X	EP 0 180 436 A2 (IWASA SEWING CO LTD [JP]) 7 May 1986 (1986-05-07) * abstract; figures 1-4,8-13 * * page 2, line 27 - line 28 * * page 3, line 17 - line 24 * * page 3, line 31 - page 4, line 10 * * page 4, line 28 - page 5, line 10 * * page 7, line 8 - page 8, line 4 * * page 8, line 33 - page 9, line 16 *	1-19	
X	FR 518 828 A (ATLAS MASCHB G M B H) 31 May 1921 (1921-05-31) * the whole document *	1-7	
X	WO 2022/234510 A1 (SPRING '85 S P A [IT]) 10 November 2022 (2022-11-10) * abstract; figures 3(a)-8 * * page 6, line 16 - page 9, line 15 *	1,3,4,6, 7	TECHNICAL FIELDS SEARCHED (IPC) A44B
A	TW M 344 761 U (GUO MEI-CEN [TW]) 21 November 2008 (2008-11-21) * figure 4 *	7	
The present search report has been drawn up for all claims			
Place of search The Hague		Date of completion of the search 4 July 2024	Examiner Thielgen, Robert
CATEGORY OF CITED DOCUMENTS X : particularly relevant if taken alone Y : particularly relevant if combined with another document of the same category A : technological background O : non-written disclosure P : intermediate document		T : theory or principle underlying the invention E : earlier patent document, but published on, or after the filing date D : document cited in the application L : document cited for other reasons & : member of the same patent family, corresponding document	

EPO FORM 1503 03:82 (P04C01)

**ANNEX TO THE EUROPEAN SEARCH REPORT
ON EUROPEAN PATENT APPLICATION NO.**

EP 24 16 0474

5 This annex lists the patent family members relating to the patent documents cited in the above-mentioned European search report.
The members are as contained in the European Patent Office EDP file on
The European Patent Office is in no way liable for these particulars which are merely given for the purpose of information.

04 - 07 - 2024

Patent document cited in search report	Publication date	Patent family member(s)	Publication date
DE 555264 C	20-07-1932	NONE	
EP 0180436 A2	07-05-1986	NONE	
FR 518828 A	31-05-1921	NONE	
WO 2022234510 A1	10-11-2022	EP 4346494 A1 WO 2022234510 A1	10-04-2024 10-11-2022
TW M344761 U	21-11-2008	NONE	

EPO FORM P0459

For more details about this annex : see Official Journal of the European Patent Office, No. 12/82

REFERENCES CITED IN THE DESCRIPTION

This list of references cited by the applicant is for the reader's convenience only. It does not form part of the European patent document. Even though great care has been taken in compiling the references, errors or omissions cannot be excluded and the EPO disclaims all liability in this regard.

Patent documents cited in the description

- IT 102023000003741 [0149]
- IT 102024000001353 [0149]