

(19)



(11)

EP 4 488 188 A1

(12)

EUROPEAN PATENT APPLICATION

(43) Date of publication:
08.01.2025 Bulletin 2025/02

(51) International Patent Classification (IPC):
B65D 1/26 (2006.01) B65D 25/36 (2006.01)

(21) Application number: **23183842.6**

(52) Cooperative Patent Classification (CPC):
B65D 1/265; B65D 25/36

(22) Date of filing: **06.07.2023**

(84) Designated Contracting States:
**AL AT BE BG CH CY CZ DE DK EE ES FI FR GB
 GR HR HU IE IS IT LI LT LU LV MC ME MK MT NL
 NO PL PT RO RS SE SI SK SM TR**
 Designated Extension States:
BA
 Designated Validation States:
KH MA MD TN

(72) Inventor: **Lloyd, Simon
Willingham CB245JT (GB)**

(74) Representative: **König Szynka Tilmann von
Renesse
Patentanwälte Partnerschaft mbB Düsseldorf
Mönchenwerther Straße 11
40545 Düsseldorf (DE)**

(71) Applicant: **PACCOR Packaging GmbH
40468 Düsseldorf (DE)**

(54) **PACKAGING CONTAINER FOR FOOD AND METHOD TO PRODUCE A PACKAGING CONTAINER**

(57) The present invention pertains to packaging container (2) for food comprising an outer part (4) and an inner part (6), wherein the outer part (4) comprises paper and/or cardboard, wherein the inner part (6) comprises a plastic, wherein the inner part (6) is thermoformed, wherein the inner part (6) comprises a bottom (8), a flange (10) and a wall (12), wherein the wall (12) connects the flange (10) and the bottom (8), wherein the

outer part (4) is at least partially enclosing the inner part (6), wherein in particular the outer part (4) is enclosing the wall (12) of the inner part (6), wherein the inner part (6) comprises a circumferential shoulder (14) at the bottom (8), wherein the outer part (4) is arranged on the shoulder (14) and the shoulder (14) supports the outer part (4), wherein the shoulder (14) comprises at least one recess (16).

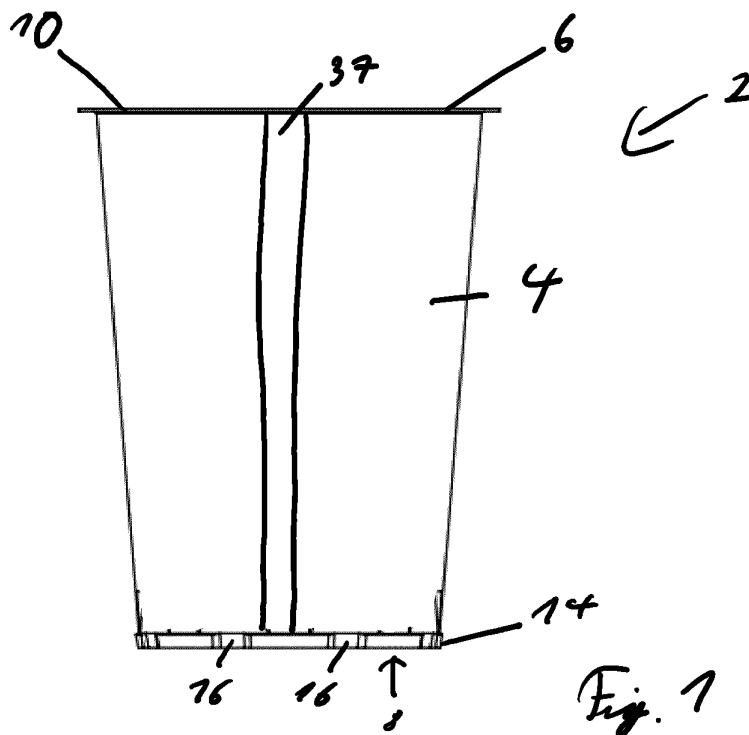

EP 4 488 188 A1

Description**FIELD OF THE INVENTION**

[0001] The present invention pertains to a packaging container for food and a method to produce a packaging container.

BACKGROUND OF THE INVENTION

[0002] The packaging container for food is used to store different types of food for example yoghurt, drinks or coffee.

[0003] The packaging container for food comprises an outer part and an inner part. The outer part usually comprises paper and/or cardboard. The inner part comprises a plastic, wherein the inner part is thermoformed. The inner part comprises a bottom, a flange, and a wall, wherein the wall connects the flange and the bottom. Usually, the outer part is at least partially enclosing the inner part, wherein in particular the outer part is enclosing the wall of the inner part. Therefore, the inner part comprises a circumferential shoulder at the bottom and wherein the outer part is arranged on the shoulder and the shoulder supports the outer part.

[0004] The combination of the inner part comprising a plastic and the outer part comprising paper and/or cardboard enables the adjustment of the mechanical properties of the packaging container. Thus, a packaging container with beneficial mechanical properties for storing, transportation and filling can be achieved by the combination of the materials.

[0005] Moreover, because of the outer part, which comprises paper and/or cardboard, the inner part can be thin. Hence, less plastic is used for a packaging container, so that the production of the packaging container is environmentally friendly. Further, the inner part and the outer part can be separated so that the different materials of the packaging container can be recycled separately. In doing so, the recycling and consequently the environmental friendliness of the packaging container is improved.

[0006] However, the attachment of the outer part to the inner part is difficult. The outer part is arranged on the shoulder and supported by the shoulder. Hence, the outer part and the inner part are mainly connected by the shoulder. Though, the shoulder is usually rounded and small, because the shoulder is an undercut during the thermoforming of the inner part. Thus, the shoulder hinders the removal of the inner part as force must be applied to remove the shoulder from the thermoforming machine. Consequently, only small shoulders can be produced to enable a removal of the inner part from the thermoforming machine. Big shoulders would be destroyed during the removal.

[0007] A small shoulder badly supports the outer part. Hence, a detachment of the outer part from the inner part regularly happens. After the detachment of the outer part

from the inner part the packaging container is disposed, or the outer part is manually attached to the inner part.

[0008] In addition, during the filling of the packaging container there is high humidity. Thus, the outer part comprising paper and/or cardboard expands and falls off.

[0009] To prevent the separation of the inner part and the outer part usually the outer part is fixed to the inner part by an adhesive bond. However, this complicates the recycling of the packaging container. On the one hand, the adhesive bond is another material that is used to manufacture the packaging container. Hence, for recycling besides the inner part and the outer part, the adhesive bond must be separated and recycled separately. Hence, another separation step and recycling step is necessary for the adhesive bond. On the other hand, the adhesive bond complicates the separation or even self-separation of the outer part and the inner part. Usually, the region of the packaging container, where the outer part is adhesively bonded to the inner part cannot be separated mechanically. Thus, there is a region of the packaging container that cannot be mechanically separated since the adhesive bond joins the inner part and the outer part. Consequently, this region cannot be recycled.

[0010] For example, from EP 2 377 766 A1 a packaging container is known with an inner part and an outer part. The inner part comprises two, three or more radially outwardly projecting support projections arranged one behind the other in the circumferential direction. However, to fix the outer part firmly to the inner part EP 2 377 766 A1 also recommends gluing the outer part on the inner part. This complicates the recycling of the packaging container.

[0011] Based on this prior art it is the object of the invention to provide an environmentally friendly and durable packaging container, which is also cost-effective and efficient. It is another object of the invention to provide a method to produce a packaging container.

SUMMARY OF THE INVENTION

[0012] According to a first aspect of the invention the object is solved by a packaging container for food comprising an outer part and an inner part, wherein the outer part comprises paper and/or cardboard, wherein the inner part comprises a plastic, wherein the inner part is thermoformed, wherein the inner part comprises a bottom, a flange and a wall, wherein the wall connects the flange and the bottom, wherein the outer part is at least partially enclosing the inner part, wherein in particular the outer part is enclosing the wall of the inner part, wherein the inner part comprises a circumferential shoulder at the bottom, wherein the outer part is arranged on the shoulder and the shoulder supports the outer part, wherein the shoulder comprises at least one recess.

[0013] The at least one recess facilitates the removal of the inner part since the shoulder is more flexible because of the recesses. Therefore, the shoulder is improved as it is larger and it is also not destroyed during the removal

from the thermoforming machine. Hence, the support of the outer part by the shoulder of the inner part is significantly improved. Hereby, the connection of the outer part to the inner part is enhanced. Therefore, during filling, transport and storing a detachment of the outer part from the inner part can be prevented. Therefore, the waste is reduced as the packaging container is more durable and thus environmentally friendly. Further, due to the reduction of waste the packaging container is more efficient and more cost-effective. Moreover, there is no need to attach the outer part for example by an adhesive bond to the inner part, so that the recycling of the packaging container is facilitated. Thus, the packaging container becomes more environmentally friendly. In addition, due to the better support of the outer part by the inner part the force transmission from the inner part to the outer part and vice versa is enhanced, so that the packaging container is more durable.

[0014] The packaging container for food can be used for yoghurt, drinks and/or coffee. The packaging container can be impermeable to fluids, in particular water. The packaging container can comprise a lid and/or a covering foil to seal the packaging container. The packaging container can have the shape of truncated cone, wherein in particular the packaging container tapers from the flange to the bottom.

[0015] The outer part can fit snugly to the inner part. The outer part can comprise recycled paper and/or recycled cardboard. The outer part can consist of paper, in particular recycled paper, and/or cardboard, in particular recycled cardboard. The outer part is at least partially enclosing the inner part can mean that the outer surface of the inner part is at least partially covered by the outer part. If the outer part can be enclosing the wall of the inner part a very reliable and sustainable force transmission can be assured. In addition, a contamination of the outer part for example by liquids can be prevented, so that the paper and/or cardboard cannot soak the liquid. Hence, the packaging container becomes more durable. The outer part can be printed.

[0016] The inner part can form a hollow space for storing the food. The inner part can limit this hollow space. The packaging container can be configured such that only the inner part can contact the food. The flange of the inner part can comprise a sealing edge. In doing so, the packaging container can be easily closed. The inner part can consist of a plastic.

[0017] Thermoforming can be a manufacturing process. During thermoforming a sheet of plastic can be heated to a pliable temperature, formed into a specific shape in a mould and in particular cut into a usable product. The sheet can be heated in an oven to a temperature high enough to stretch it into or onto a mould and cool it to a finished shape. Hence, the inner part can only comprise materials which can be thermoformed. Those materials can have a high elastic elongation. The inner part can have a wall with continuous or slightly reducing wall thickness from the flange to the bottom due to the

thermoforming.

[0018] The circumferential shoulder can be placed at the bottom. The bottom can be the lowest tenth of the inner part. The shoulder can be arranged on the outside of the inner part. The shoulder can have a wider diameter than the bottom. The diameter can be the extension in the radial direction. The diameter can be the extension perpendicular to the longitudinal axis. The longitudinal axis can extend from the centre of the bottom to the centre of the flange. The shoulder can have a rectangular cross section perpendicular to the radial axis. In doing so, the shoulder can be very durable and provide a good support for the outer part. Hence, the packaging container can be produced without an adhesive bond so that the packaging container can be more environmentally friendly.

[0019] The outer part is arranged on the shoulder and the shoulder supports the outer part. The outer part can have no connection to the ground. Hence, the weight of the outer part and the forces applied to the outer part can only be transferred to the ground via the shoulder and finally via the bottom of the inner part. The shoulder supports the outer part can mean that the outer part can rest on the shoulder of the inner part.

[0020] The outer part can be fixed between the shoulder and the flange. In this way, the outer part can be easily and securely fixed to the inner part by the shoulder and the flange. The outer part can be only attached to the inner part in an interlocking and/or force-fitting manner. In this way no substance-to-substance bond can be necessary so that the packaging container can be easy to recycle and hence more environmentally friendly.

[0021] The at least one recess can have smaller radius than the shoulder at its maximum circumference. The at least one recess can lay behind the outer edge of the shoulder in the radial direction. The radius can be the extension in the radial direction. The radius can be the extension perpendicular to the longitudinal axis. The longitudinal axis can extend from the centre of the bottom to the centre of the flange. The shoulder can comprise any number of recesses. The at least one recess can be a material recess. The at least one recess can have the recess of the bottom. In doing so, the at least one recess can be an area at the bottom without the shoulder. In the cross section along the longitudinal axis the radius of the shoulder can change, wherein the at least one recess can have a smaller radius than the residual part of the shoulder.

[0022] In one embodiment the shoulder can comprise a holding range, wherein the holding range can extend in the radial direction of the shoulder, wherein the holding range can be between the outer edge of the shoulder and the intersection of the surface of the shoulder and the connecting line from the flange to the bottom along the wall, wherein the holding range can be at least 0.3 mm, preferably at least 0.8 mm and most preferably at least 1.5 mm.

[0023] In doing so, the shoulder can efficiently and

stably support the outer part. Therefore, the support of the outer part by the shoulder of the inner part can be significantly improved. Hereby, the connection of the outer part to the inner part can be enhanced. Therefore, during filling, transport and storing a detachment of the outer part from the inner part can be prevented. Therefore, the waste can be reduced as the packaging container can be more durable and thus environmentally friendly. Further, due to the reduction of waste the packaging container can be more efficient and more cost-effective. Moreover, there can be no need to attach the outer part for example by an adhesive bond to the inner part, so that the recycling of the packaging container can be facilitated. Thus, the packaging container can become more environmentally friendly. In addition, due to the better support of the outer part by the inner part the force transmission from the inner part to the outer part and vice versa can be enhanced, so that the packaging container can be more durable.

[0024] If the holding range can be at least 0.8 mm the connection of the outer part and the inner part can be significantly enhanced. If the holding range can be at least 1.5 mm a detachment of the inner part and the outer part can be prevented.

[0025] The holding range can support the outer part. The outer part can be arranged on the holding range. The holding range can be a circumferential plane on the upper surface of the shoulder.

[0026] The radial direction of the shoulder can be perpendicular to the longitudinal axis. The longitudinal axis can extend from the centre of the bottom to the centre of the flange. The holding range can extend in the radial direction, while at the same time also extend to a certain amount in along the longitudinal axis. The holding range can be inclined to the radial axis, but it can still extend in the radial direction in this case.

[0027] The outer edge of the shoulder can be the part of the shoulder with the largest radius starting from the longitudinal axis. The outer edge of the shoulder can be part of the shoulder which extends furthest in the radial direction of the shoulder. The outer edge can be the maximum circumference of the shoulder.

[0028] The intersection of the surface of the shoulder and the connecting line from the flange to the bottom along the wall can be connection point of the wall and the surface of the shoulder. The connecting line can extend from the flange to the bottom along the wall on the outside of the inner part. If the wall can comprise an undercut or any other minor geometrical feature like an elevation or an indentation, the connecting line can linearly extend along the main portion of the surface of the wall. The connecting line can be linear. The surface of the shoulder can be the upper surface of the shoulder. The upper surface of the shoulder can be the plane facing the flange of the inner part.

[0029] In one embodiment the at least one recess can be offset towards the centre of the inner part compared to the outer edge of the shoulder, wherein the at least one

recess can be connected with the outer edge of the shoulder by at least one ramp, wherein in particular the at least one ramp can have an angle of 10°-80°, preferably 30°-60°, most preferably 40°-50°.

[0030] In doing so, the connection of the outer edge of the shoulder and the at least one recess can be very stable and reliable as a material cracking at the connection can be prevented. Hence, the inner part can be durable so that the packaging container can be very durable, which can make the packaging container very environmentally friendly and cost-effective.

[0031] If the ramp can have an angle of 10°-80° a material breach can reliably be prevented. If the ramp can have an angle of 30°-60° the durability can be enhanced.

[0032] If the ramp can have an angle of 40°-50° a material breach can reliably be prevented. In addition, the removal of the inner part from the thermoforming machine can be simplified so that larger shoulders can be produced. Hence, the attachment of the outer part to the inner part can be improved so that the packaging container can be very durable, which can make the packaging container very environmentally friendly and cost-effective.

[0033] The ramp can be a flat surface that can be inclined to the outer edge of the shoulder and/or to the circumference of the at least one recess. The ramp can have a constant gradient.

[0034] In one embodiment the at least one recess can taper in the circumferential direction along the direction from the flange to the bottom, in particular with a maximum angle of 15°, or wherein the at least one recess can have a continuous width in the circumferential direction along the direction from the flange to the bottom.

[0035] If the at least one recess can taper in the circumferential direction along the direction from the flange to the bottom, the removal of the inner part from the thermoforming machine can be simplified leading to a better shoulder. Hence, the attachment of the outer part to the inner part by the shoulder can be improved so that the packaging container can become more durable. A maximum angle of 15° can ensure a simple removal and an enhanced stability of the packaging container.

[0036] If the at least one recess can have a continuous width in the circumferential direction along the direction from the flange to the bottom, the packaging container can be very stable and durable since the continuous width can stabilise the inner part.

[0037] The direction from the flange to the bottom can be a straight line from the flange to the bottom along the wall on the outside of the inner part. If the wall can comprise an undercut or any other minor geometrical feature like an elevation or an indentation, the direction from the flange to the bottom can linearly extend along the main portion of the surface of the wall.

[0038] The circumferential direction can be the rotational direction along the wall of the inner part around the longitudinal axis of the packaging container.

[0039] Taper can mean that the width in the circumferential direction of the at least one recess decreases in the direction from the flange to the bottom of the inner part.

[0040] In one embodiment the at least one recess can be 5-80%, preferably 10-60% and most preferably 15-40% of the shoulder.

[0041] In doing so, the removal of the inner part can be simplified with increasing amount of the at least one recess. Hence, the shoulder can be larger so that the attachment of the outer part to the inner part can be improved. In doing so, no substance-to-substance bond can be necessary so that the packaging container can be easy to recycle and hence more environmentally friendly. At the same time the outer part can be durably attached to the inner part because the recess can be at most 80% of the shoulder.

[0042] If the at least one recess can be 10-60% of the shoulder the effect can be enhanced.

[0043] If the at least one recess can be 15-40% of the shoulder the effect can be further enhanced. In addition, a force can be reliably transferred from the inner part to the outer part and vice versa. Hence, the stability and the durability of the packaging container can be enhanced. Moreover, forces can also be reliably transferred from the inner part to the outer part and vice versa during crushing of the packaging container for recycling. Hence, the recycling can be simplified so that the packaging container can become more environmentally friendly.

[0044] The amount of the at least one recess can be the amount of the circumference of the shoulder which can consist of the at least one recess. The circumference of the shoulder can be the outer edge of the shoulder running in the circumferential direction.

[0045] In one embodiment the shoulder can comprise at least two recesses, and wherein the at least two recesses can be spaced apart in the circumferential direction.

[0046] In doing so, the removal of the inner part can be further simplified. Thus, the shoulder can be larger so that the attachment of the outer part to the inner part can be improved.

[0047] In one embodiment the at least two recesses can be equidistantly arranged in the circumferential direction.

[0048] In doing so, the removal of the inner part can be simplified. Hence, the shoulder can be larger so that the attachment of the outer part to the inner part can be improved. Equidistantly arranged can mean that in the circumferential direction of the inner part the at least two recesses can be separated by the same angle. For example, two recesses can be spaced apart by 180°, while four recesses can be spaced apart by 90°.

[0049] In one embodiment the inner part can comprise a stacking edge, wherein the stacking edge can be arranged on the inside of the inner part, and wherein the stacking edge can be circumferential.

[0050] In doing so, the packaging containers can be efficiently stored and transported. Hence, the packaging

container can become more environmentally friendly and more cost-effective.

[0051] The stacking edge can be an element configured to prevent packaging containers from attaching firmly to each other. The stacking edge can comprise a plane perpendicular to the longitudinal axis of the packaging container. The plane of the stacking edge can be configured to receive the bottom of a packaging container.

[0052] In one embodiment the stacking edge can comprise at least one interruption, and wherein in particular the at least one interruption can taper in the circumferential direction along the direction from the flange to the bottom, in particular with a maximum angle of 15°, or wherein in particular the at least one interruption can have a continuous width in the circumferential direction along the direction from the flange to the bottom.

[0053] This can have the advantage that the flexibility of the inner part for the removal from the thermoforming machine is further increased. Thus, the removal of a larger shoulder can be simplified. Hence, the attachment of the outer part to the inner part can be improved. Thus, the packaging container can be very cost-effective and environmentally friendly since a detachment and hence waste can be prevented.

[0054] If the at least one interruption can taper in the circumferential direction along the direction from the flange to the bottom, the removal of the inner part from the thermoforming machine can be simplified leading to a better shoulder. Hence, the attachment of the outer part to the inner part by the shoulder can be improved so that the packaging container can become more durable. A maximum angle of 15° can ensure a simple removal and an enhanced stability of the packaging container.

[0055] If the at least one interruption can have a continuous width in the circumferential direction along the direction from the flange to the bottom, the packaging container can be very stable and durable since the continuous width can stabilise the inner part.

[0056] Taper can mean that the width in the circumferential direction of the at least one interruption decreases in the direction from the flange to the bottom of the inner part.

[0057] The at least one interruption can have larger diameter than the minimum circumference of the stacking edge. The at least one interruption can extend further in the radial direction than the stacking edge. The diameter can be the extension in the radial direction. The diameter can be the extension perpendicular to the longitudinal axis. The longitudinal axis can extend from the centre of the bottom to the centre of the flange. The stacking edge can comprise any number of interruptions. The at least one interruption can have the diameter of the wall. In doing so, the at least one interruption can be an area at the wall without a stacking edge.

[0058] The stacking edge can comprise at least two interruptions, wherein the at least two interruptions can be spaced apart in the circumferential direction. The at

least two interruptions can be equidistantly arranged in the circumferential direction.

[0059] In one embodiment the at least one interruption can be 5-90%, preferably 20-75% and most preferably 35-60% of the stacking edge.

[0060] In doing so, the removal of the inner part can be simplified with increasing amount of the at least one interruption. Hence, the shoulder can be larger so that the attachment of the outer part to the inner part can be improved. At the same time the stacking of packaging containers can be assured because the at least one interruption is at most 90% of the stacking edge.

[0061] If the at least one interruption can be 20-75% of the stacking edge the effect can be enhanced.

[0062] If the at least one interruption can be 35-60% of the stacking edge the effect can be further enhanced. In addition, since the at least one interruption can be 35-60% of the stacking edge the flexibility of the inner part can be enhanced. Therefore, the shoulder can be maximized so that a force can be reliably transferred from the inner part to the outer part and vice versa. Hence, the stability and the durability of the packaging container can be enhanced. Moreover, during transport and storing forces can also be reliably transferred from one packaging container to another packaging container and absorbed from the packaging container by the stacking edge. Hence, the packaging container can be more durable.

[0063] The amount of the at least one interruption can be the amount of the circumference of the stacking edge which can consist of the at least one interruption. The circumference of the stacking edge can be the inner edge of the stacking edge running in the circumferential direction.

[0064] In one embodiment the at least one recess can be spaced apart in the circumferential direction from the at least one interruption.

[0065] In doing so, the flexibility of the inner part can be significantly increased due to the at least one recess and the at least one interruption. As the at least one recess and the at least one interruption can be spaced apart from each other, different regions of the inner part can be more flexible because of the at least one recess and the at least one interruption. Hence, the removal from the thermoforming machine can be further simplified in the different regions where the at least one recess and the at least one interruption can be located. Thus, the removal of a larger shoulder can be simplified. Hence, the attachment of the outer part to the inner part can be increased. Thus, the packaging container can be very cost-effective and environmentally friendly since a detachment and hence waste can be prevented. At the same time the function of the shoulder and the stacking edge can be assured.

[0066] Spaced apart can be mean that the at least one recess and the at least one interruption can be located at different regions along the circumference of the packaging container around the longitudinal axis. Additionally, the at least one recess and the at least one interruption

can be spaced apart along the longitudinal axis.

[0067] In one embodiment the at least one interruption can extend further in the circumferential direction of the inner part than the at least one recess.

5 **[0068]** In this way, the flexibility of the inner part can be maximized for the removal from the thermoforming machine. Therefore, the removal of a larger shoulder can be simplified, so that the attachment of the outer part to the inner part can be increased. Here, the flexibility can be increased by the at least one interruption, which can extend further in the circumferential direction of the inner part than the at least one recess. At the same time the at least one recess can be smaller in the circumferential direction, so that the part of the shoulder supporting the outer part can be larger. Hence, the attachment of the outer part to the inner part can be improved, while at the same time the removal of a larger shoulder can be simplified due to the increased flexibility by the at least one interruption.

20 **[0069]** In one embodiment the outer part can comprise at least one separation region.

[0070] In doing so, the outer part and the inner part can be easily separated to facilitate the separation of the outer part and the inner part. In this way, the recycling of the packaging container can be simplified. Hence, the packaging container can be more environmentally friendly. In particular, due to the at least one recess and/or the at least one interruption the outer part can be safely attached to the inner part so that no additional bonding can be needed. Hence, the at least one recess and/or the at least one interruption in combination with the at least one separation region improve the recyclability of the packaging container so that the packaging container can be more environmentally friendly.

30 **[0071]** Therefore, the outer part can comprise a planar material, the planar material can include a first periphery and a diametrically opposed second periphery, the planar material can include an upper periphery and a diametrically opposed lower periphery, the peripheries can at least generally limit the planar material, the planar material can have a front side and a rear side, the planar material can include a first connecting portion which can be disposed at the first periphery and between the upper periphery and the lower periphery, the planar material can have a second connecting portion which can be disposed at the second periphery and between the upper periphery and the lower periphery, the planar material can include a separation region, the separation region being disposed between the first connecting portion and the second connecting portion, the separation region extending at least partially from the lower periphery to the upper periphery, wherein the separation region can comprise a central separation portion, an upper separation portion and a lower separation portion, wherein the upper separation portion can be disposed above the central separation portion and between the central separation portion and the upper periphery, wherein the lower separation portion can be disposed below the

central separation portion and between the central separation portion and the lower periphery, wherein the upper separation portion and the lower separation portion can each have at least one front incision on the front side, wherein the front incision can extend at least partially from the lower periphery to the upper periphery, wherein the upper separation portion and the lower separation portion can each have at least one rear incision on the rear side, wherein the rear incision can extend at least partially from the lower periphery to the upper periphery, wherein the central separation portion can have at least one opening.

[0072] In this way, the outer part can be reliably and easily detached from the inner part, so that the packaging container can be particularly easy to recycle and can thus be particularly environmentally friendly.

[0073] The outer part can comprise a planar material, said planar material can include a first periphery, a diametrically opposed second periphery, said planar material can include an upper periphery and a diametrically opposed lower periphery, said peripheries can at least generally limit said planar material, said planar material can have a front side and a rear side, wherein the planar material can have a first connecting portion disposed at the first periphery and between the upper periphery and the lower periphery, wherein the planar material can have a second connecting portion disposed at the second periphery and between the upper periphery and the lower periphery, wherein the planar material can include a perforation, wherein said perforation can be disposed between said first connecting portion and said second connecting portion, said perforation can extend at least partially from said upper periphery to said lower periphery, said perforation can comprise a plurality of incisions into and/or through said planar material, said incisions can be at least partially lined up in sequence and can define predetermined separation portions by common spacing, wherein at least one incision can be formed as an engagement incision for manual engagement into or through the planar material so that the predetermined separation portions can be separated, wherein the perforation can comprise a central perforation portion, an upper perforation portion and a lower perforation portion, wherein the upper perforation portion can be disposed above the central perforation portion and between the central perforation portion and the upper periphery, wherein the lower perforation portion can be disposed below the central perforation portion and between the central perforation portion and the lower periphery, wherein the upper perforation portion, said lower perforation portion and said central perforation portion can each comprise at least one of said incisions, said engagement incision can be associated with said central perforation portion, said engagement incision can have an upper end, said upper end being located closer to said upper perforation portion than to said lower perforation portion, said upper perforation portion can comprise a lower incision wherein the lower incision can be located closest

to the engagement incision, wherein the lower incision can have a lower end, wherein the engagement incision can have a lower end, wherein the lower end can be located closer to the lower perforation portion than to the upper perforation portion, wherein the lower perforation portion can have an upper incision, wherein the upper incision can be located closest to the engagement incision, wherein the upper incision can have an upper end, wherein the upper end of the engagement incision can be spaced apart from and located below the lower end of the lower incision, wherein the lower end of the engagement incision can be spaced apart from and located above the upper end of the upper incision.

[0074] In this way, the outer part can be reliably and easily detached from the inner part, so that the packaging container can be particularly recyclable and thus particularly environmentally friendly.

[0075] In one embodiment the inner part can comprise polyethylene terephthalate, in particular recycled polyethylene terephthalate, polystyrene, in particular recycled polystyrene, and/or polypropene, in particular recycled polypropene, or wherein the inner part can consist of polyethylene terephthalate, in particular recycled polyethylene terephthalate, polystyrene, in particular recycled polystyrene, and/or polypropene, in particular recycled polypropene.

[0076] Polyethylene terephthalate can be particularly light, so that the inner part and thus also the packaging container can be particularly light. In this way, energy can be saved when transporting the packaging container due to its light weight. In this way, the packaging container can be more environmentally friendly.

[0077] Polypropylene can be easily processed so that the inner part can be manufactured precisely. Thus, the inner part can be particularly thin, so that the inner part and thus also the packaging container can be produced with particularly little material. This means that material can be saved, and the packaging container can be particularly light. This means that resources can be conserved, and energy can be saved when transporting the packaging container due to its low weight. This can reduce the environmental impact. In addition, polypropylene can shrink after forming so that the removal of the inner part can be simplified.

[0078] Polystyrene can be thin and can be at the same time very durable. In addition, polystyrene can provide a large temperature window for manufacture and can be easy to thermoform. Moreover, polystyrene can be thermoformed without pre-heating. Hence, the inner part can be produced very efficiently and cost effectively.

[0079] Furthermore, polyethylene terephthalate, polystyrene and polypropylene can be easily recycled so that the inner part can be reused. This can avoid waste and by reusing polyethylene terephthalate and/or polypropylene, resources can be saved. This can reduce the impact on the environment.

[0080] Recycled polyethylene terephthalate, recycled polystyrene and/or recycled polypropylene can be ob-

tained from already used polyethylene terephthalate, polystyren and/or polypropylene. Thus, already used polyethylene terephthalate, polystyren and/or polypropylene can be saved from disposal. Furthermore, no new polyethylene terephthalate, polystyren and/or polypropylene can be used for the production of the inner part and thus also of the packaging container, so that resources can be conserved. This can reduce the burden on the environment.

[0081] According to a second aspect of the invention the object is solved by a method to produce a packaging container, in particular a packaging container according to the invention, comprising the steps:

- Providing a plastic blank,
- Thermoforming the plastic blank into an inner part, wherein the inner part comprises a circumferential shoulder at the bottom, wherein the shoulder comprises at least one recess,
- Arranging an outer part on the outside of the inner part, such that the outer part is arranged on the shoulder and the shoulder supports the outer part.

[0082] The method provides the advantage that the at least one recess facilitates the removal of the inner part since the shoulder is more flexible because of the recesses. Therefore, the shoulder is lager and is also not destroyed during the removal from the thermoforming machine. Hence, the support of the outer part by the shoulder of the inner part is significantly improved. Hereby, the connection of the outer part to the inner part is enhanced. Therefore, during filling, transport and storing a detachment of the outer part from the inner part can be prevented. Therefore, the waste is reduced so that the packaging container is more durable and thus environmentally friendly. Further, due to the reduction of waste the packaging container is more efficient and more cost-effective. Moreover, there is no need to attach the outer part for example by an adhesive bond to the inner part, so that the recycling of the packaging container is facilitated. Thus, the method provides a more environmentally friendly packaging container. In addition, due to the better support of the outer part by the inner part the force transmission from the inner part to the outer part and vice versa is enhanced, so that the method provides a more durable packaging container.

[0083] Other objects, features, advantages and aspects of the present invention will become apparent to those skilled in the art from the following description and appended claims. It should be understood, however, that the following description, appended claims, and specific examples, which indicate preferred embodiments of the application, are given by way of illustration only. Various changes and modifications within the spirit and scope of the disclosed invention will become readily apparent to those skilled in the art from reading the following.

DEFINITIONS

[0084] As used herein, the following expressions are generally intended to preferably have the meanings as set forth below, except to the extent that the context in which they are used indicates otherwise.

[0085] The expression "comprise", as used herein, besides its literal meaning also includes and specifically refers to the expressions "consist essentially of" and "consist of". Thus, the expression "comprise" refers to embodiments wherein the subject-matter which "comprises" specifically listed elements does not comprise further elements as well as embodiments wherein the subject-matter which "comprises" specifically listed elements can and/or indeed does encompass further elements. Likewise, the expression "have" is to be understood as the expression "comprise", also including and specifically referring to the expressions "consist essentially of" and "consist of". The term "consist essentially of", where possible, in particular refers to embodiments wherein the subject-matter comprises 20% or less, in particular 15% or less, 10% or less or especially 5% or less further elements in addition to the specifically listed elements of which the subject-matter consists essentially of.

FIGURES

[0086]

Figure 1 shows a packaging container.

Figure 2 shows an inner part.

Figure 3 shows an enlargement of the bottom region of the inner part.

Figure 4 shows a cross-section through the bottom of the inner part.

Figure 5 shows an inner part from underneath.

Figure 6 shows an inner part from above.

Figure 7 shows an outer part.

Figure 8 shows an outer part.

DETAILED DESCRIPTION OF THE INVENTION

[0087] Figure 1 shows a packaging container. The packaging container 2 for food comprises an outer part 4 and an inner part 6. The outer part 4 comprises paper and/or cardboard. The inner part 6 comprises a plastic, wherein the inner part 6 is thermoformed. The inner part 6 comprises a bottom 8, a flange 10 and a wall 12, wherein the wall 12 connects the flange 10 and the bottom 8. The outer part 4 is at least partially enclosing the inner part 6.

The outer part 4 is enclosing the wall 12 of the inner part 6. The inner part 6 comprises a circumferential shoulder 14 at the bottom 8. The outer part 4 is arranged on the shoulder 14 and the shoulder 14 supports the outer part 4. The shoulder 14 comprises recesses 16.

[0088] Figure 2 shows an inner part. The inner part 6 comprises a plastic, wherein the inner part 6 is thermoformed. The inner part 6 comprises a bottom 8, a flange 10 and a wall 12, wherein the wall 12 connects the flange 10 and the bottom 8. The inner part 6 comprises a circumferential shoulder 14 at the bottom 8. The shoulder 14 comprises recesses 16.

[0089] Figure 3 shows an enlargement of the bottom region of the inner part. The shoulder 14 comprises a holding range 18, wherein the holding range 18 extends in the radial direction R of the shoulder 14. The holding range 18 is between the outer edge 20 of the shoulder 14 and the intersection I of the surface of the shoulder 14 and the connecting line from the flange 10 to the bottom 8 along the wall 12. The holding range 18 is at least 0.3 mm. The holding range can also be at least 0.8 mm or at least 1.5 mm.

[0090] Figure 4 shows a cross-section through the bottom of the inner part. The shoulder 14 comprises a holding range 18, wherein the holding range 18 extends in the radial direction R of the shoulder 14. The holding range 18 is between the outer edge 20 of the shoulder 14 and the intersection I of the surface of the shoulder 14 and the connecting line from the flange 10 to the bottom 8 along the wall 12. The holding range 18 is at least 0.3 mm. The holding range can also be at least 0.8 mm or at least 1.5 mm.

[0091] The intersection of the surface of the shoulder and the connecting line from the flange to the bottom along the wall is the connection point of the wall and the surface of the shoulder. The connecting line extends from the flange to the bottom along the wall on the outside of the inner part. Since the wall comprises an indentation, the connecting line extends linearly along the main portion of the surface of the wall as indicated by the dotted line.

[0092] As shown in Fig. 3 the recesses 16 are offset towards the centre of the inner part 6 compared to the outer edge 20 of the shoulder 14. The recesses 16 are connected with the outer edge 20 of the shoulder 14 by ramps 22. The ramps 22 have an angle of 10°-80°. The ramps 22 can also have an angle of 30°-60° or 40°-50°.

[0093] The recesses 16 have a continuous width W1 in the circumferential direction C along the direction D from the flange 10 to the bottom 8. Alternatively, the recesses 16 can taper in the circumferential direction C along the direction D from the flange 10 to the bottom 8, in particular with a maximum angle of 15°.

[0094] The recesses 16 are 15-40% of the shoulder 14.

[0095] Figure 5 shows an inner part 6 from underneath. The shoulder 14 comprises eight recesses 16. The eight recesses 16 are spaced apart in the circumferential direction C. The eight recesses 16 are equidistantly ar-

ranged in the circumferential direction C. The eight recesses 16 are 15-40% of the shoulder 14.

[0096] Figure 6 shows an inner part 6 from above. The inner part 6 comprises a stacking edge 24, wherein the stacking edge 24 is arranged on the inside of the inner part 6, and wherein the stacking edge 24 is circumferential.

[0097] The stacking edge 24 comprises eight interruptions 26. The eight interruptions 26 are 35-60% of the stacking edge 24.

[0098] The eight interruptions 26 have a continuous width W2 in the circumferential direction C along the direction D from the flange 10 to the bottom 8 as can be seen in Fig. 3. Alternatively, the interruptions 26 can taper in the circumferential direction C along the direction D from the flange 10 to the bottom 8, in particular with a maximum angle of 15°.

[0099] As can be seen in Fig. 2, the recesses 16 are spaced apart in the circumferential direction C from the interruptions 26. The interruptions 26 extend further in a circumferential direction C than the recesses 16.

[0100] As can be seen in Fig. 1, the outer part 4 comprises at least one separation region 37.

[0101] Figure 7 shows an outer part. The outer part 4 comprises a planar material 30, the planar material 30 comprising a first periphery 31 and a diametrically opposed second periphery 32. The planar material 30 comprises an upper periphery 33 and a diametrically opposed lower periphery 34, the peripheries 31, 32, 33, 34 at least generally limiting the planar material 30. The planar material 30 has a front side and a rear side.

[0102] The planar material 30 has a first connecting portion 35 disposed at the first periphery 31 and between the upper periphery 33 and the lower periphery 34. The planar material 30 has a second connection portion 36 disposed at the second periphery 32 and between the upper periphery 33 and the lower periphery 34.

[0103] The planar material 30 includes a separation region 37, the separation region 37 being disposed between the first connection portion 35 and the second connection portion 36. The separation region 37 extends at least partially from the lower periphery 34 to the upper periphery 33. The separation region 37 includes a central separation portion 38, an upper separation portion 39 and a lower separation portion 40. The upper separation portion 39 is disposed above the central separation portion 39 and between the central separation portion 39 and the upper periphery 33. The lower separation portion 40 is arranged below the central separation portion 38 and between the central separation portion 38 and the lower periphery 34.

[0104] The upper separation portion 39 and the lower separation portion 40 each have at least one front incision 41 on the front side, the front incision 41 extending at least partially from the lower periphery 34 to the upper periphery 33. The upper separation portion 39 and the lower separation portion 40 each have at least one rear incision 42 on the rear side, the rear incision 42 extending at least

partially from the lower periphery 34 to the upper periphery 33. The central separation portion 38 has at least one opening 43.

[0105] Figure 8 shows an outer part. The outer part 4 comprises a planar material 30, the planar material 30 comprising a first periphery 31 and a diametrically opposed second periphery 32. The planar material 30 comprises an upper periphery 33 and a diametrically opposed lower periphery 34, the peripheries at least generally bounding the planar material 30. The planar material 30 has a front side and a rear side. The planar material 30 has a first connecting portion 35 disposed at the first periphery 31 and between the upper periphery 33 and the lower periphery 34. The planar material 30 has a second connection portion 36 disposed at the second periphery 32 and between the upper periphery 33 and the lower periphery 34. The planar material 30 includes a perforation 44, the perforation 44 being disposed between the first connection portion 35 and the second connection portion 36.

[0106] The perforation 44 extends at least partially from the upper periphery 33 to the lower periphery 34, the perforation 44 comprising a plurality of incisions 45 into and/or through the planar material 30. The incisions 45 are at least partially lined up in sequence and define predetermined separation portions by common spacing. At least one incision is formed as an engagement incision 46 for manual engagement with or through the planar material 30 so that the predetermined separation portions can be separated. The perforation 44 comprises a central perforation portion 47, an upper perforation portion 48 and a lower perforation portion 49.

[0107] The upper perforation portion is disposed above the central perforation portion 47 and between the central perforation portion 47 and the upper periphery 33. The lower perforation portion is disposed below the central perforation portion 47 and between the central perforation portion 47 and the lower periphery 34. The upper perforation portion, the lower perforation portion and the central perforation portion each comprise at least one of the incisions 45, wherein the engagement incision 46 is associated with the central perforation portion 47.

[0108] The engagement incision 46 has an upper end, the upper end being disposed closer to the upper perforation portion 48 than to the lower perforation portion 49. The upper perforation portion has a lower incision, the lower incision being disposed closest to the engagement incision 46. The lower incision has a lower end, wherein the engagement incision 46 has a lower end. The lower end is disposed closer to the lower perforation portion 49 than to the upper perforation portion 48, the lower perforation portion having an upper incision. The upper incision is disposed closest to the engagement incision 46, the upper incision having an upper end, the upper end of the engagement incision being spaced apart from and disposed below the lower end of the lower incision. The lower end of the engagement portion is spaced from and above the upper end of the upper incision.

[0109] The inner part 6 comprises polyethylene terephthalate, in particular recycled polyethylene terephthalate, polystyrene, in particular recycled polystyrene, and/or polypropene, in particular recycled polypropene. Alternatively, the inner part 6 consists of polyethylene terephthalate, in particular recycled polyethylene terephthalate, polystyrene, in particular recycled polystyrene, and/or polypropene, in particular recycled polypropene.

Claims

1. Packaging container (2) for food comprising an outer part (4) and an inner part (6),

wherein the outer part (4) comprises paper and/or cardboard,

wherein the inner part (6) comprises a plastic,

wherein the inner part (6) is thermoformed,

wherein the inner part (6) comprises a bottom (8), a flange (10) and a wall (12),

wherein the wall (12) connects the flange (10) and the bottom (8),

wherein the outer part (4) is at least partially enclosing the inner part (6),

wherein in particular the outer part (4) is enclosing the wall (12) of the inner part (6),

wherein the inner part (6) comprises a circumferential shoulder (14) at the bottom (8),

wherein the outer part (4) is arranged on the shoulder (14) and the shoulder (14) supports the outer part (4),

characterized in that
the shoulder (14) comprises at least one recess (16).

2. Packaging container according to claim 1, **characterized in that**

the shoulder (14) comprises a holding range (18),

wherein the holding range (18) extends in the radial direction (R) of the shoulder (14),

wherein the holding range (18) is between the outer edge (20) of the shoulder (14) and the intersection (I) of the surface of the shoulder (14) and the connecting line from the flange (10) to the bottom (8) along the wall (12),

wherein the holding range (18) is at least 0.3 mm, preferably at least 0.8 mm and most preferably at least 1.5 mm.

3. Packaging container according to claim 1 or 2, **characterized in that**

the at least one recess (16) is offset towards the centre of the inner part (6) compared to the outer

- edge (20) of the shoulder (14),
 wherein the at least one recess (16) is connected with the outer edge (20) of the shoulder (14) by at least one ramp (22),
 wherein in particular the at least one ramp (22) has an angle of 10°-80°, preferably 30°-60°, most preferably 40°-50°.
4. Packaging container according to any one of claims 1 to 3,
characterized in that
 the at least one recess (16) tapers in the circumferential direction (C) along the direction (D) from the flange (10) to the bottom (8), in particular with a maximum angle of 15°, or wherein the at least one recess (16) has a continuous width (W1) in the circumferential direction (C) along the direction (D) from the flange (10) to the bottom (8).
5. Packaging container according to any one of claims 1 to 4,
characterized in that
 the at least one recess (16) is 5-80%, preferably 10-60% and most preferably 15-40% of the shoulder (14).
6. Packaging container according to any one of claims 1 to 5,
characterized in that
 the shoulder (14) comprises at least two recesses (16), and wherein the at least two recesses (16) are spaced apart in the circumferential direction (C).
7. Packaging container according to claim 6,
characterized in that
 the at least two recesses (16) are equidistantly arranged in the circumferential direction (C).
8. Packaging container according to any one of claims 1 to 7,
characterized in that
 the inner part (6) comprises a stacking edge (24), wherein the stacking edge (24) is arranged on the inside of the inner part (6), and wherein the stacking edge (24) is circumferential.
9. Packaging container according to claim 8,
characterized in that
 the stacking edge (24) comprises at least one interruption (26), and wherein in particular the at least one interruption (26) tapers in the circumferential direction (C) along the direction (D) from the flange (10) to the bottom (8), in particular with a maximum angle of 15°, or wherein in particular the at least one interruption (26) has a continuous width (W2) in the circumferential direction (C) along the direction (D) from the flange (10) to the bottom (8).
10. Packaging container according to claim 8 or 9,
characterized in that
 the at least one interruption (26) is 5-90%, preferably 20-75% and most preferably 35-60% of the stacking edge (24).
11. Packaging container according to any one of claims 8 to 10,
characterized in that
 the at least one recess (16) is spaced apart in the circumferential direction (C) from the at least one interruption (26).
12. Packaging container according to any one of claims 8 to 11,
characterized in that
 the at least one interruption (26) extends further in a circumferential direction (C) than the at least one recess (16).
13. Packaging container according to any one of claims 1 to 12,
characterized in that
 the outer part (4) comprises at least one separation region (37).
14. Packaging container according to any one of claims 1 to 13,
characterized in that
 the inner part (6) comprises polyethylene terephthalate, in particular recycled polyethylene terephthalate, polystyrene, in particular recycled polystyrene, and/or polypropene, in particular recycled polypropene, or wherein the inner part (6) consists of polyethylene terephthalate, in particular recycled polyethylene terephthalate, polystyrene, in particular recycled polystyrene, and/or polypropene, in particular recycled polypropene.
15. Method to produce a packaging container (2), in particular a packaging container (2) according to any of the preceding claims, comprising the steps:
 - Providing a plastic blank,
 - Thermoforming the plastic blank into an inner part (6), wherein the inner part (6) comprises a circumferential shoulder (14) at the bottom (8),

wherein the shoulder (14) comprises at least one recess (16),

- Arranging an outer part (4) on the outside of the inner part (6), such that the outer part (4) is arranged on the shoulder (14) and the shoulder (14) supports the outer part (4).

10

15

20

25

30

35

40

45

50

55

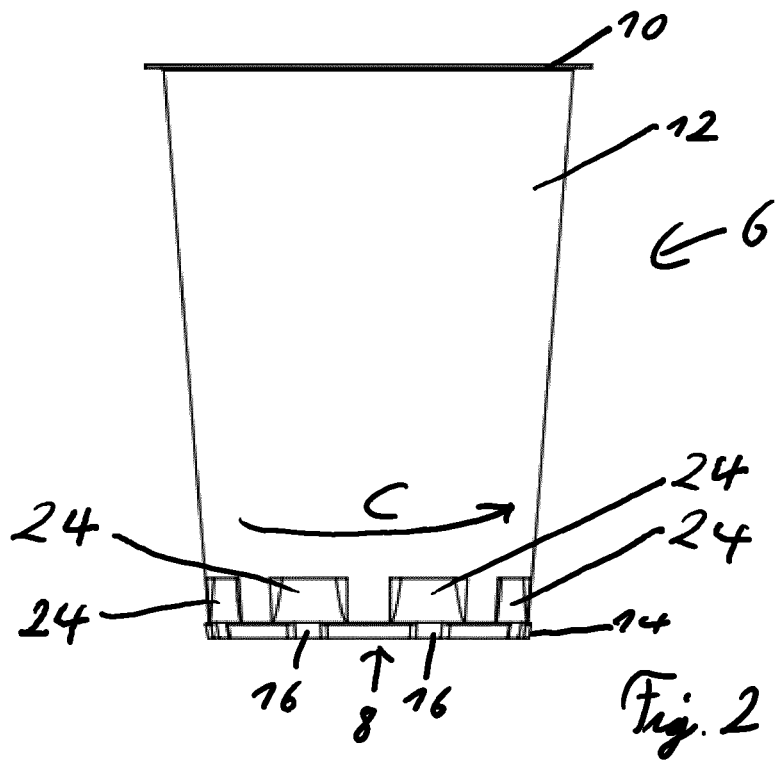
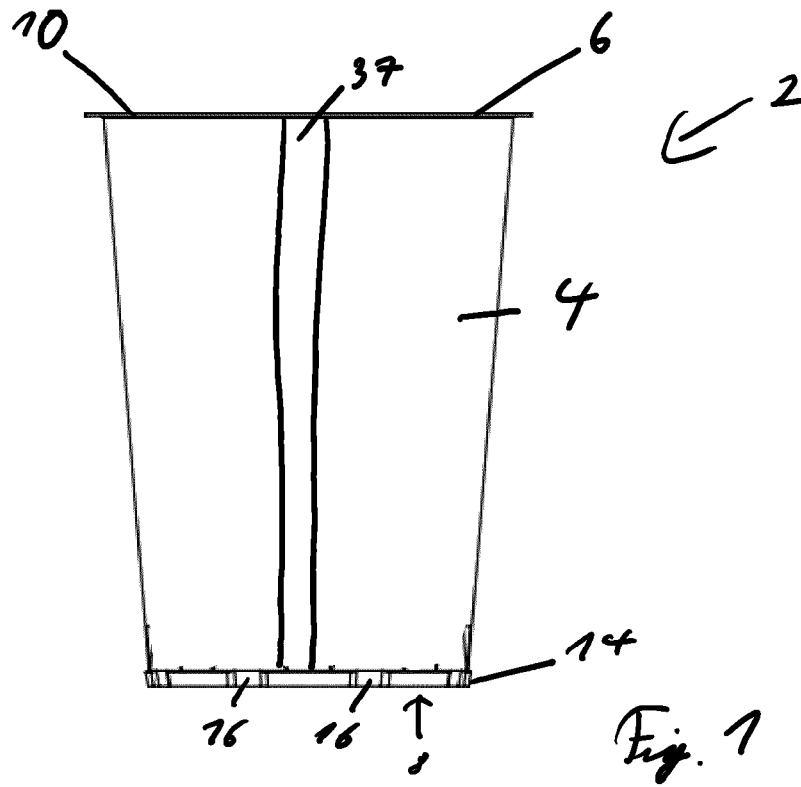

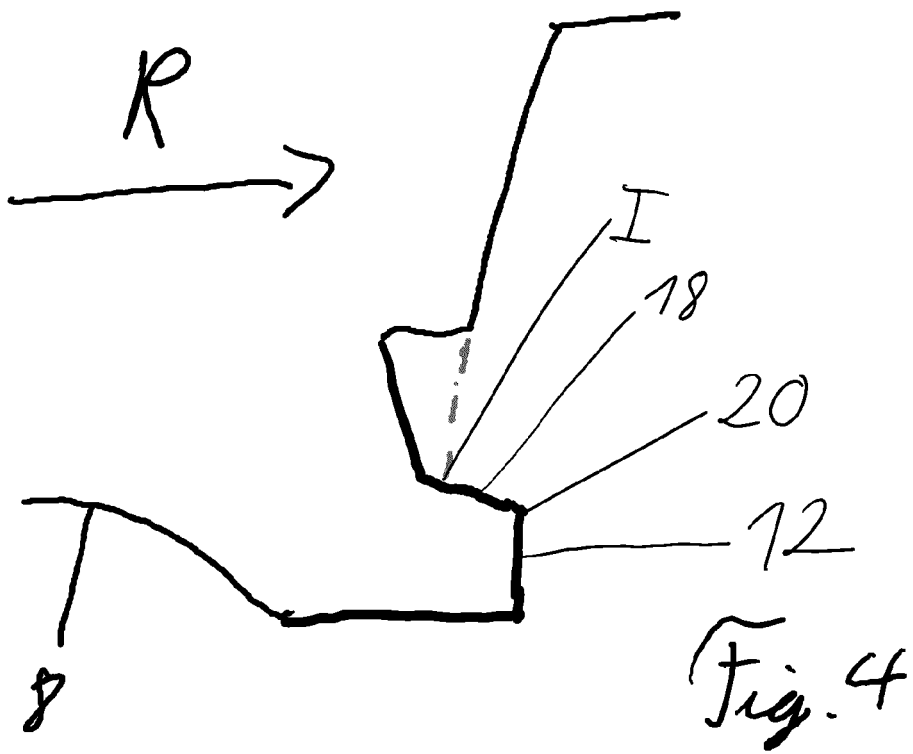
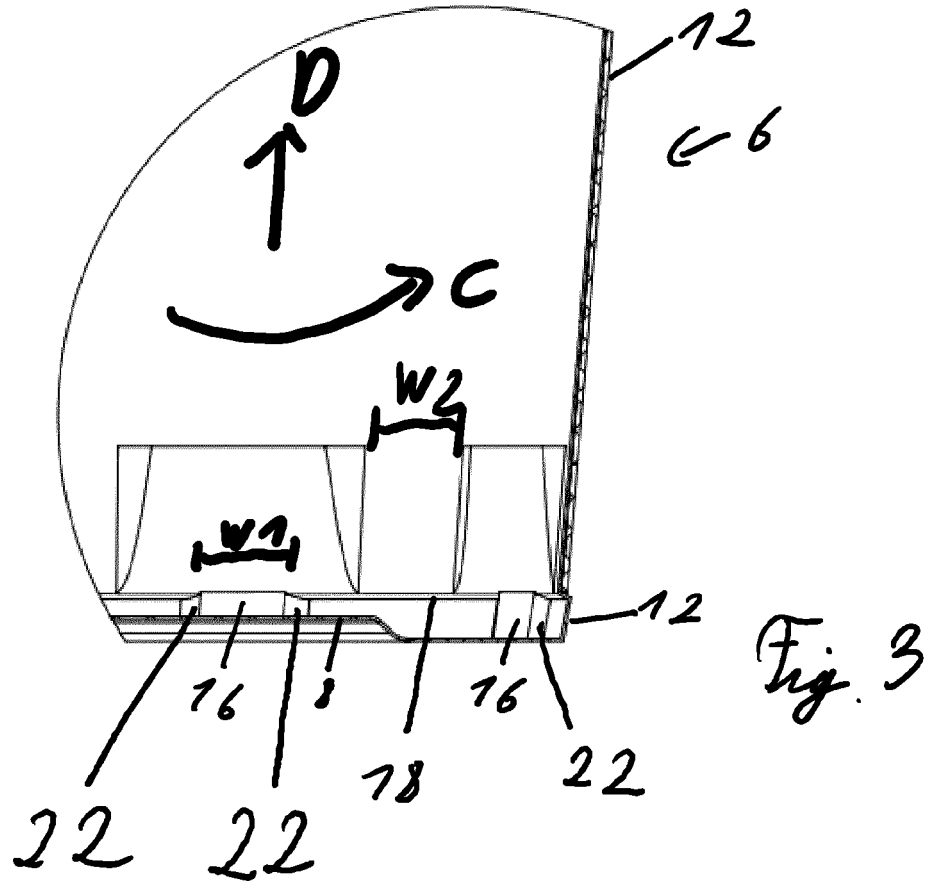

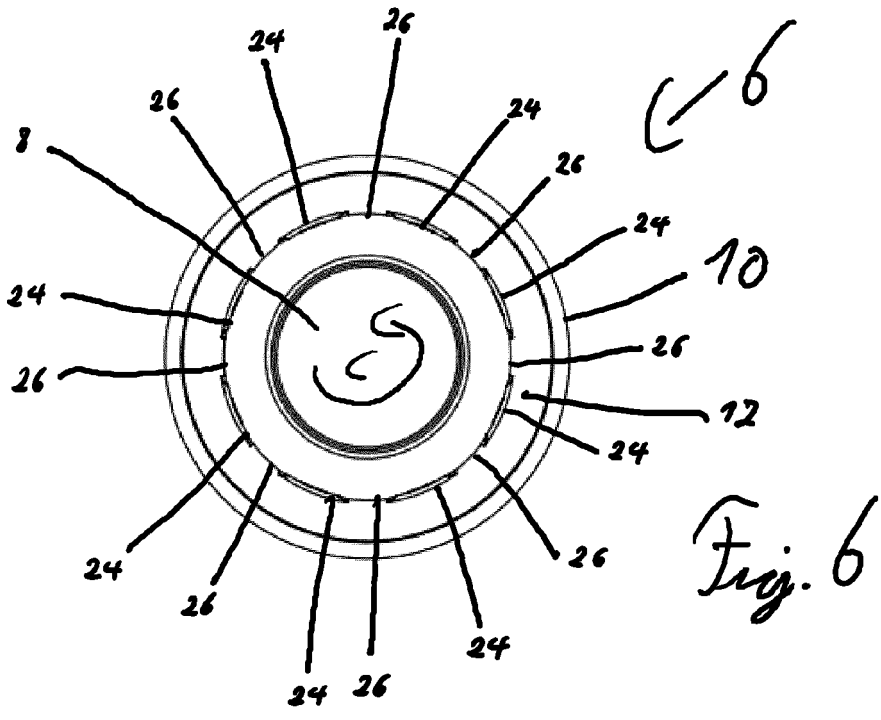
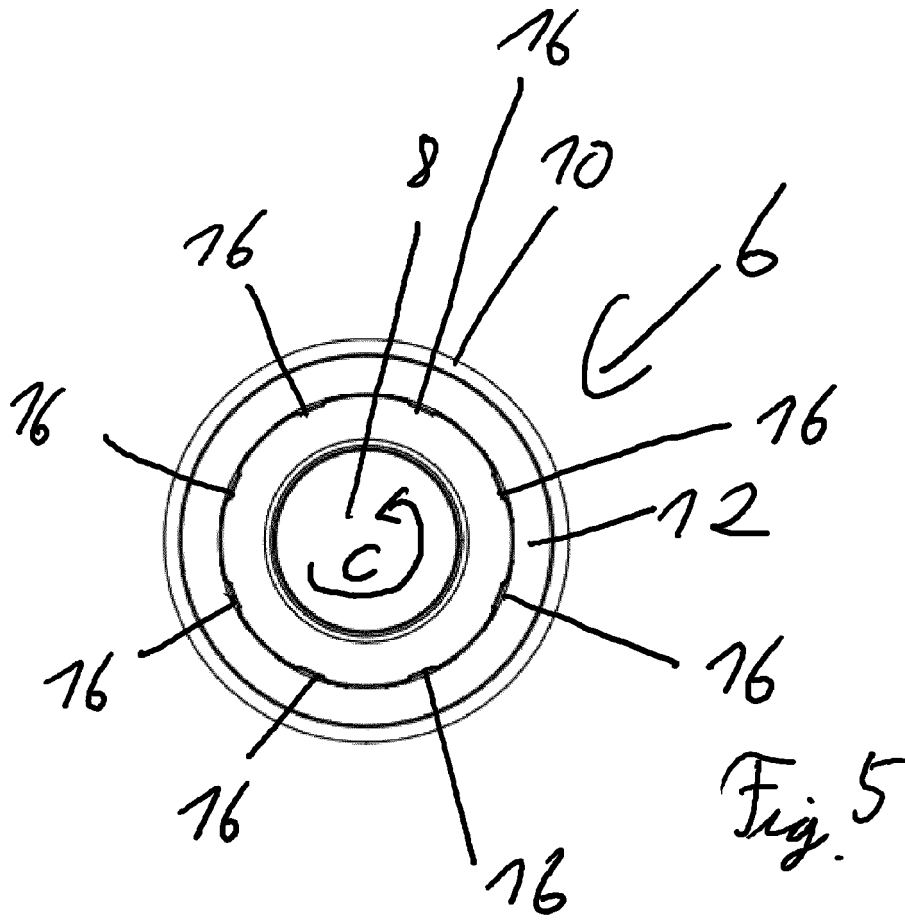

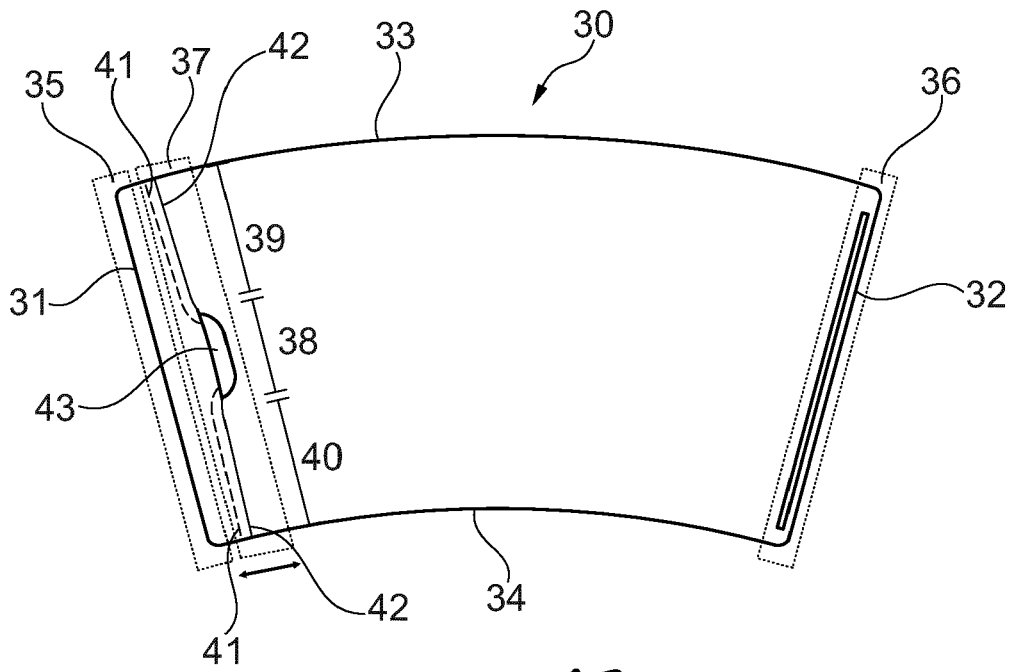

Fig. 7

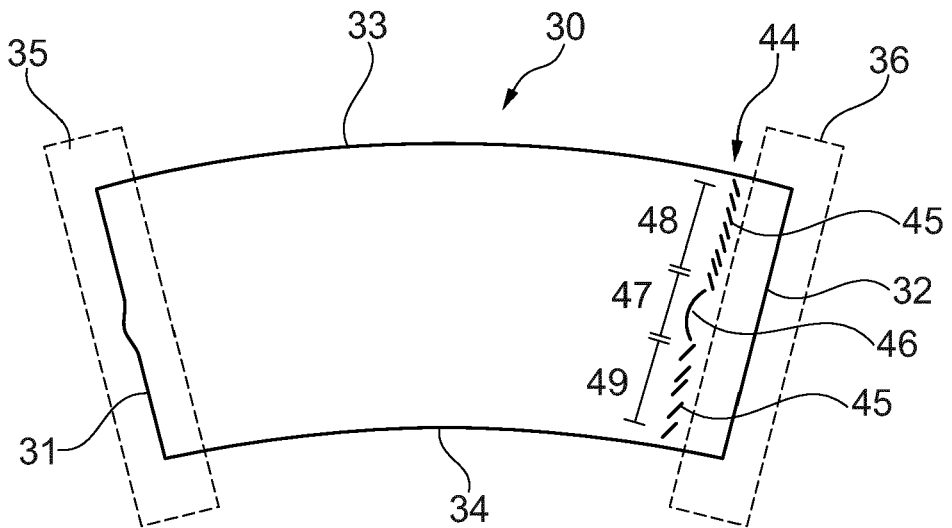

Fig. 8



EUROPEAN SEARCH REPORT

Application Number
EP 23 18 3842

5

10

15

20

25

30

35

40

45

50

55

DOCUMENTS CONSIDERED TO BE RELEVANT			
Category	Citation of document with indication, where appropriate, of relevant passages	Relevant to claim	CLASSIFICATION OF THE APPLICATION (IPC)
X	WO 2022/180079 A1 (GREINER PACKAGING AG [CH]) 1 September 2022 (2022-09-01) * page 19, line 22 - page 35, line 29; figures 1-13 *	1-15	INV. B65D1/26 B65D25/36
A	DE 20 2020 000644 U1 (GIZEH VERPACKUNGEN GMBH & CO KG [DE]) 18 May 2021 (2021-05-18) * paragraph [0027] - paragraph [0033]; figures 1-3 *	1-15	
A	EP 2 272 774 A2 (HUHTAMAEMI OYJ [FI]) 12 January 2011 (2011-01-12) * paragraph [0013] - paragraph [0015]; figures 1,2 *	1-15	
X	DE 20 2010 005753 U1 (OPTIPACK GMBH [DE]) 2 September 2010 (2010-09-02) * paragraph [0029] - paragraph [0034]; figures 1a-5b *	1-15	
			TECHNICAL FIELDS SEARCHED (IPC)
			B65D
The present search report has been drawn up for all claims			
Place of search Munich		Date of completion of the search 26 October 2023	Examiner Lämmel, Gunnar
CATEGORY OF CITED DOCUMENTS		T : theory or principle underlying the invention E : earlier patent document, but published on, or after the filing date D : document cited in the application L : document cited for other reasons & : member of the same patent family, corresponding document	
X : particularly relevant if taken alone Y : particularly relevant if combined with another document of the same category A : technological background O : non-written disclosure P : intermediate document			

1
EPO FORM 1503 03.82 (P04C01)

**ANNEX TO THE EUROPEAN SEARCH REPORT
ON EUROPEAN PATENT APPLICATION NO.**

EP 23 18 3842

5 This annex lists the patent family members relating to the patent documents cited in the above-mentioned European search report.
The members are as contained in the European Patent Office EDP file on
The European Patent Office is in no way liable for these particulars which are merely given for the purpose of information.

26-10-2023

Patent document cited in search report	Publication date	Patent family member(s)	Publication date
WO 2022180079 A1	01-09-2022	CA 3211080 A1 WO 2022180079 A1	01-09-2022 01-09-2022

DE 202020000644 U1	18-05-2021	NONE	

EP 2272774 A2	12-01-2011	EP 2272774 A2 WO 2011124290 A1	12-01-2011 13-10-2011

DE 202010005753 U1	02-09-2010	NONE	

EPO FORM P0459

For more details about this annex : see Official Journal of the European Patent Office, No. 12/82

REFERENCES CITED IN THE DESCRIPTION

This list of references cited by the applicant is for the reader's convenience only. It does not form part of the European patent document. Even though great care has been taken in compiling the references, errors or omissions cannot be excluded and the EPO disclaims all liability in this regard.

Patent documents cited in the description

- EP 2377766 A1 [0010]