

(19)



(11)

EP 4 488 193 A1

(12)

EUROPEAN PATENT APPLICATION

(43) Date of publication:
08.01.2025 Bulletin 2025/02

(51) International Patent Classification (IPC):
B65D 43/16^(2006.01) B65D 55/02^(2006.01)

(21) Application number: **24184622.9**

(52) Cooperative Patent Classification (CPC):
B65D 43/162; B65D 55/024

(22) Date of filing: **26.06.2024**

(84) Designated Contracting States:
AL AT BE BG CH CY CZ DE DK EE ES FI FR GB GR HR HU IE IS IT LI LT LU LV MC ME MK MT NL NO PL PT RO RS SE SI SK SM TR
Designated Extension States:
BA
Designated Validation States:
GE KH MA MD TN

(71) Applicant: **Bormioli Pharma S.p.A.**
20123 Milano (IT)

(72) Inventor: **PAGANUZZI, Valerio**
43126 Parma (IT)

(74) Representative: **Monelli, Alberto**
Bugnion S.p.A.
Largo Michele Novaro 1/A
43121 Parma (IT)

(30) Priority: **03.07.2023 IT 202300013803**

(54) **A CONTAINER OF A PRODUCT**

(57) Container of a product comprising:
-a vessel (2) intended to contain the product and comprising a base (22) and an opening (24) for removing the product; said opening (24) being opposite the base (22);
-a lid (3) of the vessel intended to occlude said opening (24);
-a tamper-evident seal (4) connecting the lid (3) to the vessel (2).

The tamper-evident seal (4) comprises a tab (41) and a constraining element (42) for constraining the tab (41); said tab (41) and said constraining element (42) comprising a hole (413) and the other a projection (420) suitable for interacting with the hole (413). The tamper-evident seal (4) assumes at least a first configuration in which the seal (4) signals that the container (1) is intact and a second configuration in which the seal (4) signals tam-

pering; both in the first and in the second configuration:
i) said hole (413) and said projection (420) are mutually engaged;
ii) the tab (41) and the constraining element (42) define two distinct bodies assembled to each other.

In the first configuration one from among said lid (3) and said vessel (2) is connected as a single body to the tab (41) along a frangible zone (411), the other from among said lid (3) and said vessel (2) comprises said constraining element (42).

In the second configuration said tab (41) is fractured along the frangible zone (411).

In the second configuration said hole (413) and said projection (420) enable a displacement of the tab (41) towards the base (22) of the vessel (2) with respect to the first configuration.

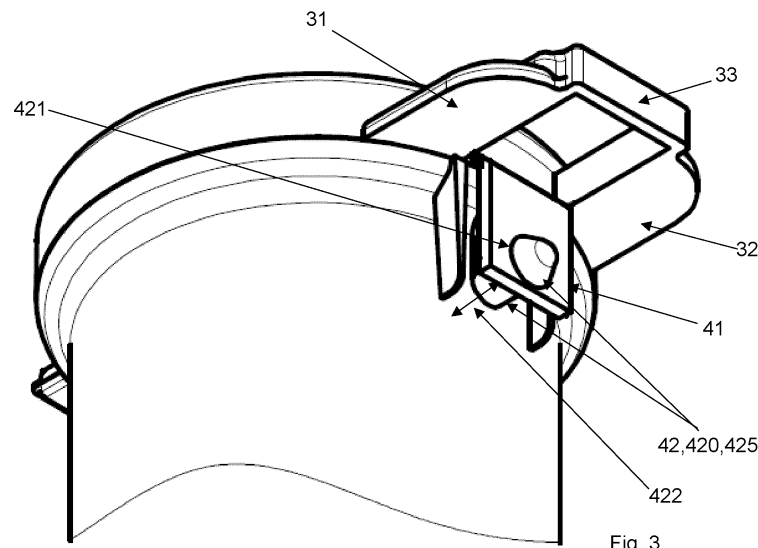
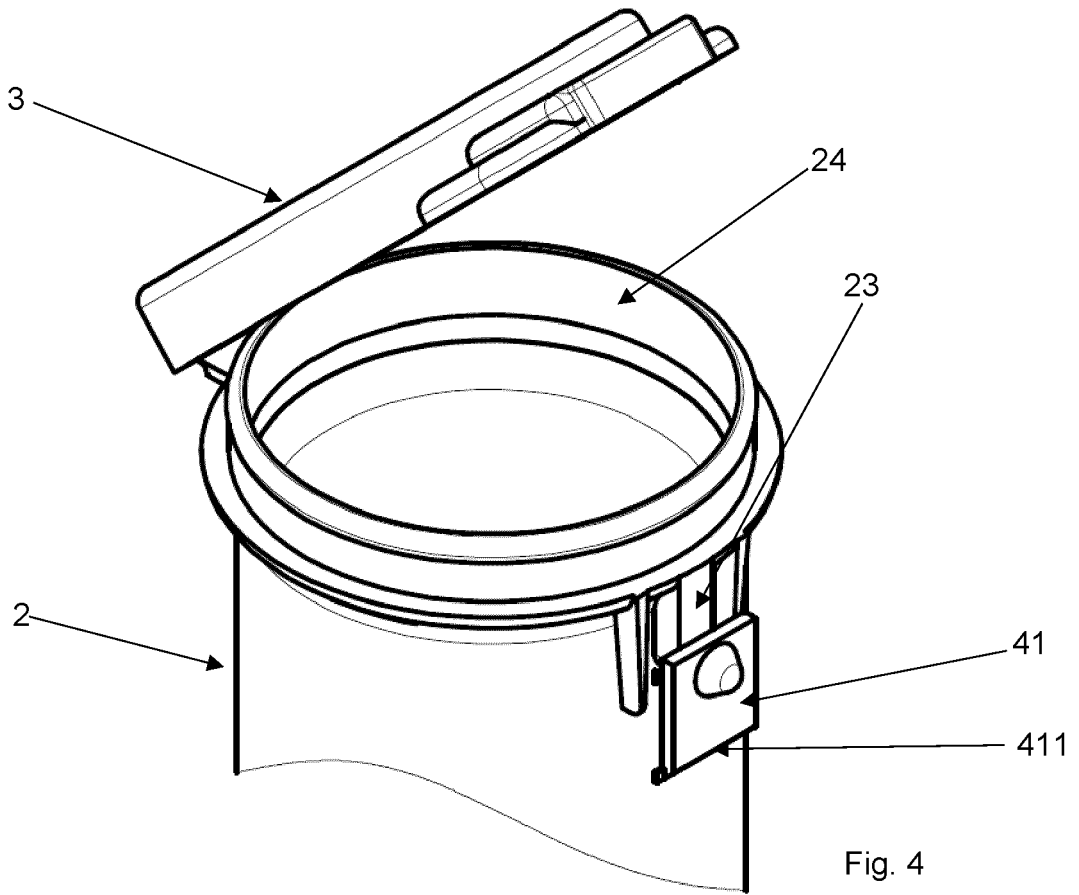

Fig. 3

EP 4 488 193 A1



Description

[0001] The present invention relates to a container of a product. Typically, this is a container intended to contain tablets or granular/powdered products. In fact, it typically defines a pillbox. Possibly the container could also be intended to contain at least one liquid.

[0002] Solutions of the type described in WO01/44102 are known. It describes a container provided with a vessel and a hinged lid provided with a tamper-evident seal.

[0003] In such a solution, there is a tab constrained to the vessel and there are a through slot and a blind slot in the lid, intended to interact with the tab. Before filling, the tab is inserted in the blind slot. Being blind, the notch of the tab cannot grasp the lid and therefore the lid can be opened and closed countless times. After filling, the tab is inserted in the through slot and the notch of the tab immovably engages the lid. To enable opening, the tab is torn off at the base, remaining constrained to the lid.

[0004] By observing the base of the tab, the user can therefore determine whether or not the container has been tampered with. A drawback of such a solution is related to the fact that a user must pay particular attention to understand whether the base of the tab has been cut or not. In fact, the latter will tend to reposition itself in the position assumed before being torn off.

[0005] The object of the present invention is to provide a container of a product which makes any tampering more evident.

[0006] The technical task set and the objects specified are substantially attained by a system, comprising the technical features as set out in one or more of the accompanying claims.

[0007] Further features and advantages of the present invention will become more apparent from the indicative and thus non-limiting description of a preferred but non-exclusive embodiment of a container, as illustrated in the attached drawings in which:

- figure 1 shows a front view of the container according to the present invention;
- figures 2 and 3 show a detail of a portion of the container in a first configuration from different viewpoints;
- figures 4 and 5 show the detail of figures 2 and 3 in a second configuration from different viewpoints;
- figures 6 and 7 show the detail of figures 2 and 3 in a further configuration from different viewpoints.

[0008] In the appended drawings, reference number 1 denotes a container of a product. Typically, but not necessarily, the product is a pharmaceutical or nutraceutical product. Such a product can comprise tablets or a granular or powdered product. In a particular solution, it could also contain liquids.

[0009] The container 1 comprises a vessel 2 intended to contain the product.

[0010] Such a vessel 2 is typically shaped as a tubular

element having a base 22 occluding one end of such a tubular element. Such a base 22 can, for example, also define a support of the vessel 2 on a plane outside the container 1.

[0011] The vessel 2 comprises an opening 24 for removing the product. Such an opening 24 defines an access mouth to the contents of the vessel 2. The access opening 24 is opposite the base 22.

[0012] The vessel 2 is substantially cylindrical or truncated cone-shaped (e.g., with a slight flaring towards the mouth).

[0013] The vessel 2 also comprises a lid 3. The lid 3 is intended to occlude the opening 24. The lid 3 enables opening/closing the vessel 2. The lid 3 is openable to allow the product to be dispensed. With respect to the base 22, the lid 3 is suitably located at an opposite end of the vessel 2.

[0014] Preferably, the lid 3 is an open and close lid. In the preferred solution, the lid 3 is constrained (in particular hinged) to the vessel 2.

[0015] Therefore in a particular solution, the lid 3 is inseparably connected to the vessel 2.

[0016] Advantageously, but not necessarily, at least one part of the lid 3 and/or at least one part of the vessel 2 comprises/comprise moisture-absorbing means, typically comprises/comprise a suitable moisture-absorbing material, such as zeolite or calcium oxide.

[0017] Suitably, the lid 1 comprises a tamper-evident seal 4 connecting the lid 3 to the vessel 2.

[0018] The tamper-evident seal 4 is also known as the "tamper-evident" element.

[0019] It enables highlighting whether there has been any tampering which has allowed access to the product placed in the container. If the purchaser finds the tamper-evident seal 4 intact, he/she has the guarantee that the container has not been opened and then re-closed by a third party.

[0020] The tamper-evident seal 4 comprises a tab 41 and a constraining element 42 for constraining the tab 41. The tab 41 and the constraining element 42 define two distinct bodies which can be assembled to each other. The tab 41 and the constraining element 42 comprise one a hole 413 and the other a projection 420 suitable to interact with the hole 413. In the preferred solution the tab 41 comprises the hole 413 and the constraining element 42 comprises/is a projection 420 (but possibly in a non-illustrated and non-preferred solution it could also be the opposite).

[0021] The tamper-evident seal 4 assumes at least a first configuration in which the seal 4 signals that the container 1 is intact (see figures 1, 2, 3) and a second configuration (see figures 4, 5) in which the seal 4 signals tampering.

[0022] Both in the first and in the second configuration, the tab 41 and the constraining element 42 define two distinct bodies assembled to each other, mutually engaging the hole 413 and the projection 420.

[0023] In the first configuration one from among said lid

3 and said vessel 2 is connected as a single body to the tab 41 along a frangible zone 411; the other (from among said lid 3 and said vessel 2) comprises said constraining element 42.

[0024] Therefore in the first configuration said constraining element 42 and said tab 41 are integrated respectively one to the lid 3 and one to the vessel 2.

[0025] In the solution exemplified in figures 2 and 3, in the first configuration the lid 3 is connected as a single monolithic body to the tab 41 at the frangible zone 411 and the vessel 2 is connected as a single monolithic body to the constraining element 42 (which preferably is said projection 420 and/or said pin 425 better defined below). However, the opposite situation could also occur (solution not illustrated) in which the lid 3 in the first configuration is a single monolithic body with the constraining element 42 and the vessel 2 is a single monolithic body with the tab 41.

[0026] In the second configuration the tab 41 is fractured along the frangible zone 411. In the second configuration the hole 413 and the projection 420 enable a displacement of the tab 41 towards the base 22 of the vessel 2 with respect to the first configuration. In the second configuration, the tab 41 is not a single monolithic body with either the lid 3 or with the vessel 2.

[0027] The frangible zone 411 comprises/is a frangible line. In the frangible zone 411 (or however along the frangible line) there is a weakening zone. For example, there can be pre-fracture zones (with yielding bridges) and/or a pre-incision (e.g., a groove) which reduces thickness. This thereby defines a lead-in to the fracture.

[0028] In the second configuration, the tamper-evident seal 4 has an irreversible fracture. It is irreparably broken. This signals to the user that someone has already gained access to the inside of the vessel 2.

[0029] The constraining element 42 or the projection 420 comprises/is preferably a pin 425. In the second configuration, the tab 41 is rotatable with respect to the pin 425. In fact, after having broken along the fracture zone 411 (and thus it is separated from the lid 3 in the solution exemplified in the drawings) it is rotatable. In the solution illustrated in the appended drawings, the constraining element 42 coincides with the projection 420 and/or with the pin 425 (suitably, also the projection 420 coincides with the pin). In the course of the present discussion, what is described with reference to one of such components (42, 420, 425) can also be referred to one of the other two.

[0030] The possibility of the tab 41 being rotatable around the pin 425 makes rendering tampering more obvious. In fact, in such a case, the user will be able to more easily notice that the tab 41 is at least partially tilted (rotated) around the pin 425. Compare, for example, figure 5 (second configuration) with figure 3 (first configuration).

[0031] The pin 425 projects outwards along a direction defining the rotation axis of the tab 41 around the pin 425 itself.

[0032] In the second configuration, the tab 41 is tilted (e.g., at least partially rotated) with respect to the first configuration. It is typically tilted downwards. In the second configuration, the tab 41 is rotatable by 360° around the pin 425. Suitably, in the second configuration, the tab 41 is rotatably idle around the pin 425.

[0033] Suitably, the constraining element 42 (or rather the projection 420 or the pin 425) defines a rotation axis identifying a direction orthogonal to that of the main extension of the vessel 2. As exemplified in the appended drawings in the second configuration, said hole 413 and said projection 420 enable a displacement of the tab 41 towards said base 22, keeping the tab 421 always parallel to the same plane.

[0034] In a particular embodiment solution exemplified in the appended drawings, in the first configuration the tab 41 is constrained to the lid 3 by means of a frangible zone 411; in the second configuration said tab 41 is ripped from the lid 3 along the frangible zone 411.

[0035] In a solution not illustrated, the constraining element 42 could be a projection 420 which engages in a slot (the hole 413) afforded on the tab 41. In the second configuration, the projection 420 is movable along the slot. In particular, after the fracture of the frangible zone 411, the tab 41 can fall by gravity along the stroke allowed by the slot in which the projection 420 is inserted. In such a case, typically the tab 41 can translate with respect to the projection 420.

[0036] In general, suitably, the vessel 2 comprises a side wall 21 from which the constraining element 42 (or said projection 420 or said pin 425) projects outwards.

[0037] However, there could also be a different solution in which the tab 41 is constrained to the vessel 2 by means of the frangible zone 411 while the constraining element 42 is connected to the lid 3.

[0038] Regardless of the above, the tab 41 comprises a hole 413 into which the constraining element 42 (or the projection 420 or the pin 425) can be engaged.

[0039] The tab 41 is typically made of plastic material.

[0040] Suitably, the constraining element 42 is made of plastic material.

[0041] The constraining element 42 is cantilevered. The constraining element 42 has one end which is free. Suitably, the constraining element 42 comprises an anti-extraction countersink 421 for retaining the tab 41 to the pin 425. Suitably, the countersink 421 is placed at such a free end. Such a countersink 421 has a smaller cross-section in a zone closer to the free end and a larger cross-section in a zone farther away from the free end. Such a larger cross-section defines an abutment which retains the tab 41 (at the hole 413 thereof).

[0042] The tab 41 extends between the frangible zone 411 and an opposite end 412. The distance between said hole 413 and said frangible zone 411 is greater than the distance between said hole 413 and said opposite end 412.

[0043] Suitably, in the first configuration, the tab 41 is constrained at the frangible zone 411 and the constrain-

ing element 42.

[0044] Suitably, the vessel 2 comprises a rear abutment 23 of the tab 41. In the first configuration, the tab 41 is interposed between the countersink 421 and said abutment 23. Such an abutment 23 is, for example, a notch obtained on a side wall of the vessel 2.

[0045] Suitably, the lid 3 comprises at least one zone 30 intended to receive a prompt from a user and aimed at the passage of the lid 3 from the first to the second configuration. Such a zone 30 intended to receive a prompt from a user can comprise, for example, a flap 300 projecting from the lid 3. Suitably, such a flap 300 extends outwards from the lid 3 (and advantageously in a plane substantially parallel to the lying plane of the lid 3).

[0046] Such a flap 300 comprises, for example, a first and a second arm 31, 32 which can possibly be connected to each other by a connector 33. Typically, the first arm 31, the second arm 32 and the connector 33 define a single monolithic body, which advantageously is in turn a single monolithic body with remaining parts of the lid 3.

[0047] The user exerting (e.g., with a finger) a force on such a flap 300 directed away from the vessel 2 allows the fracture of the frangible zone 411 and thus enables the passage from the first to the second configuration.

[0048] Suitably, the container 1 can also assume a preliminary configuration (see for example figures 6 and 7) in which the tab 41 is not associated with (or rather is not directly constrained to) the pin 425. In such a case, the constraining element 42 is outside the hole 413 of the tab 41. In the preliminary configuration, the tamper-evident seal 4 does not connect vessel 2 and lid 3. Such a preliminary configuration is typically assumed before the product is inserted inside the container (e.g., at the end of the production of the container, it will be in the preliminary configuration without the product).

[0049] Suitably, the tab 41 in the preliminary configuration is located at the zone 30 intended to receive a user prompt.

[0050] In particular in the preliminary configuration, the tab 41 is parallel to the flap 300. In the passage from the preliminary configuration to the first configuration, suitably the tab 41 is folded around the frangible zone 411.

[0051] Advantageously, in the preliminary configuration the tab 41 is interposed between the first and the second arm 31, 32. In particular in the preliminary configuration the tab 41 occludes a window defined by the combination of the first arm 31, the second arm 32 and the connector 33.

[0052] In particular in the preliminary configuration the tab 41 extends parallel to the base 22. In the first and in the second configuration the tab 41 extends orthogonally to the base 22.

[0053] An object of the present invention is also a method for producing a container 1. Such a container 1 has one or more of the features described above.

[0054] The method comprises the step of providing the container 1 with the constraining element 42 and the tab 41 mutually disengaged.

[0055] The method also comprises the step of positioning the product in the vessel 2. Such a step is subsequent to that of providing the container 1 with the constraining element 42 and tab 41 mutually disengaged.

5 **[0056]** The method also comprises the step of closing the lid 3 and engaging the constraining element 42 in the tab 41, assuming the first configuration. Such an operation typically involves folding the tab 41 around the frangible zone 411 (without fracturing the frangible zone 411).
10 In particular, the constraining element 42 is engaged in the hole 413 of the tab 41. Such a step typically occurs after the step of positioning the product in the vessel 2.

[0057] Thereby, the tamper-evident seal 4 is operational.

15 **[0058]** An object of the present invention is a method for opening a container 1. Such a container 1 suitably has one or more of the features described above. The opening method comprises the steps of:

- 20 - in the first configuration, opening the lid 3, breaking at least one portion of the tab 41 which connects the lid 3 to the vessel 2; in particular, the breakage affects the frangible zone 411. The tab 41 remains constrained to the constraining element 42 (which in the solution exemplified in the appended drawings comprises/coincides with the projection 420 or the pin 425);
25 - the tab 41, being moved by gravity around the constraining element 42, assumes a different position from the one assumed in the first configuration. As just advantageously indicated, the constraining element 42 is a pin 425. The step in which the tab 41 moves by gravity around the constraining element 42 can involve the tab 41 tilting by gravity around the pin 425, assuming a different position from that assumed in the first configuration. Typically, the portion of the tab 41 with the largest mass will be arranged below the pin 425. Typically, after the breakage the frangible zone 411 is arranged towards the base 22 of the vessel. There is a rotation of about 180°, which makes the separation more evident. In fact, in such a case the tab assumes a different configuration and is more noticeable.

45 **[0059]** The present invention achieves important advantages.

[0060] Firstly, it allows to make any tampering very evident with the tamper-evident seal. This allows the user to easily verify such a condition, which is very important given the importance of the product which is intended to be contained by these containers.

50 **[0061]** The invention thus conceived is susceptible to numerous modifications and variants, all falling within the scope of the inventive concept that characterises it.
55 Furthermore, all the details may be replaced with other technically equivalent elements. All the materials used, as well as the dimensions, may in practice be any whatsoever according to needs.

Claims

1. A container of a product comprising:

- a vessel (2) intended to contain the product and comprising a base (22) and an opening (24) for removing the product; said opening (24) being opposite the base (22);
 - a lid (3) of the vessel intended to occlude said opening (24);
 - a tamper-evident seal (4) connecting the lid (3) to the vessel (2);
 the tamper-evident seal (4) comprising a tab (41) and a constraining element (42) for constraining the tab (41); one from among said tab (41) and said constraining element (42) comprising a hole (413) and the other a projection (420) suitable to interact with the hole (413); said tamper-evident seal (4) assuming at least a first configuration in which the seal (4) signals that the container (1) is intact and a second configuration in which the seal (4) signals tampering; both in the first and in the second configuration the tab (41) and the constraining element (42) define two distinct bodies assembled to each other, said hole (413) and said projection (420) being mutually engaged;
 in the first configuration one from among said lid (3) and said vessel (2) being connected as a single body to the tab (41) along a frangible zone (411), the other from among said lid (3) and said vessel (2) comprising said constraining element (42);
 in the second configuration said tab (41) being fractured along the frangible zone (411);
characterised in that in the second configuration said hole (413) and said projection (420) are suitable to enable a displacement of the tab (41) towards the base (22) of the vessel (2) with respect to the first configuration.

2. The container according to claim 1, **characterised in that** said projection (420) is a pin (425); in the second configuration the frangible zone (411) being rotatable with respect to the pin (425).

3. The container according to claim 1, **characterised in that** in the second configuration said tab (41) is tilted with respect to the first configuration.

4. The container according to claim 1 or 2, **characterised in that** in the first configuration the tab (41) is constrained to the lid (3) by means of said frangible zone (411); in the second configuration said tab (41) being ripped from the lid (3) along the frangible zone (411).

5. The container according to any one of the preceding

claims, **characterised in that** said hole (413) is afforded on the tab (41); said vessel (2) comprising a side wall (21) from which said projection (420) projects outwards; said projection (420) mainly extending along a direction (422) orthogonal to a main extension direction (25) of the vessel (2).

6. The container according to any one of the preceding claims, **characterised in that** said tab (41) extends between the frangible zone (411) and an opposite end (412); the distance between said hole (413) and said frangible zone (411) being greater than the distance between said hole (413) and said opposite end (412).

7. The container according to any one of the preceding claims, **characterised in that** in the second configuration the tab (41) is rotatable by 360° around the projection (420).

8. The container according to any one of the preceding claims, **characterised in that** in the second configuration said hole (413) and said projection (420) enable a displacement of the tab (41) towards said base (22) keeping the tab (41) always parallel to the same plane.

9. A method for producing a container according to any one of claims 1 to 8, **characterised in that** it comprises the steps of:

- providing the container (1) with said tab (41) and said constraining element (42) disengaged;
- positioning the product in the vessel (2);
- closing the lid (3) and engaging the constraining element (42) in the tab (41) assuming the first configuration.

10. The method for opening a container according to any one of claims 1 to 8, **characterised in that** it comprises the steps of:

- in the first configuration opening the lid (3) breaking at least one portion of the tab (41) which connects the lid (3) to the vessel (2); the tab (41) remaining constrained to the constraining element (42);
- the tab (41), being displaced by gravity with respect to the constraining element (42), assumes a different position from the one assumed in the first configuration.

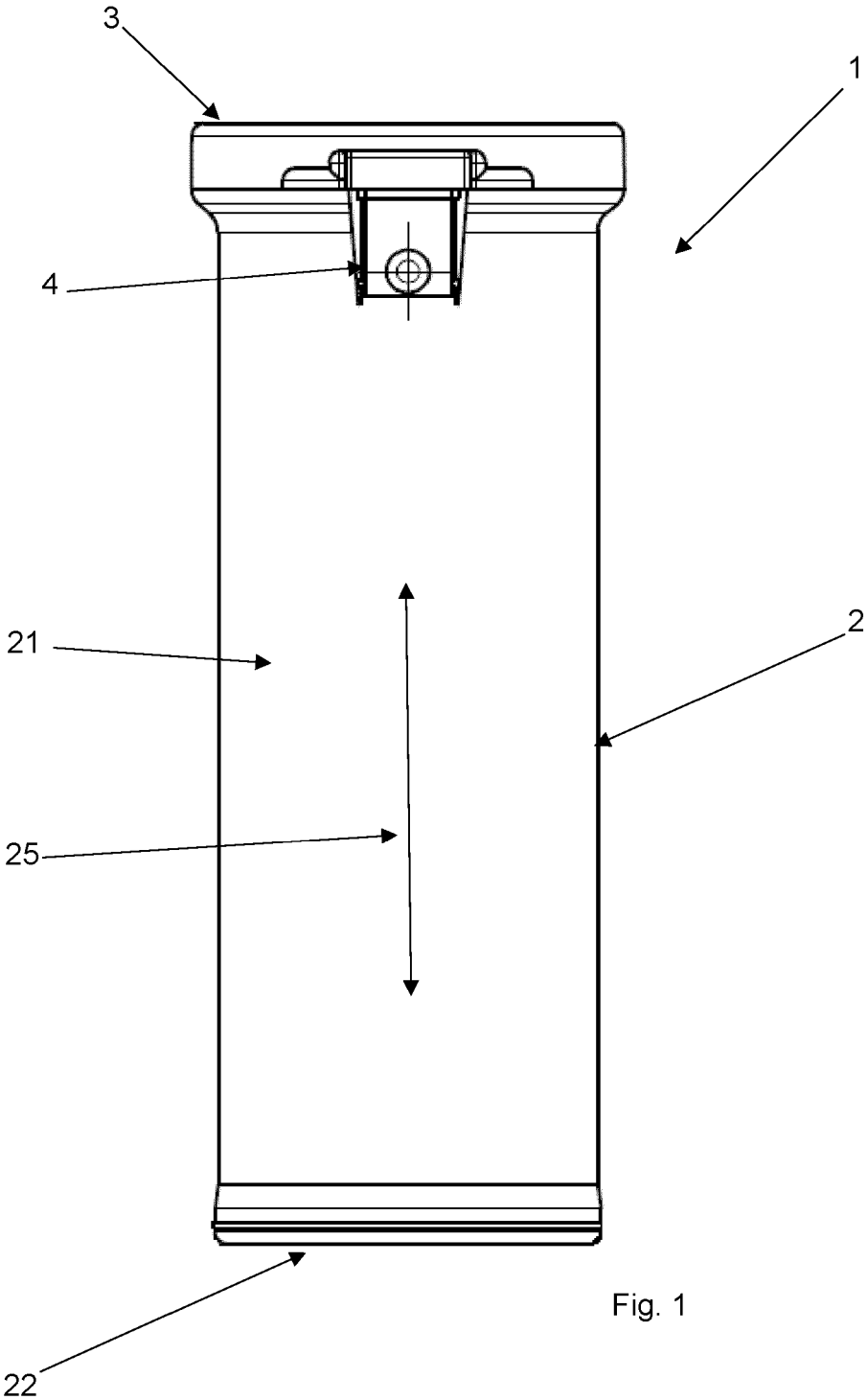
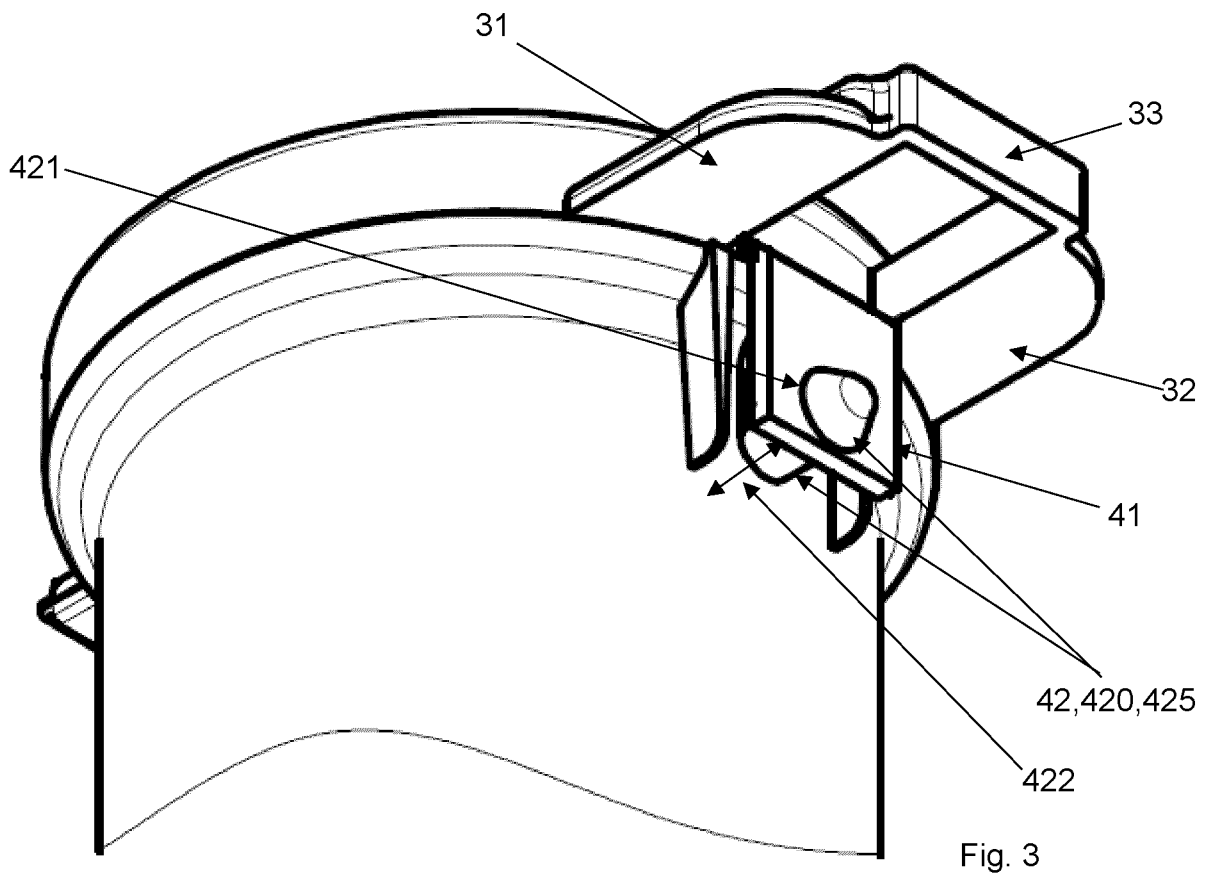
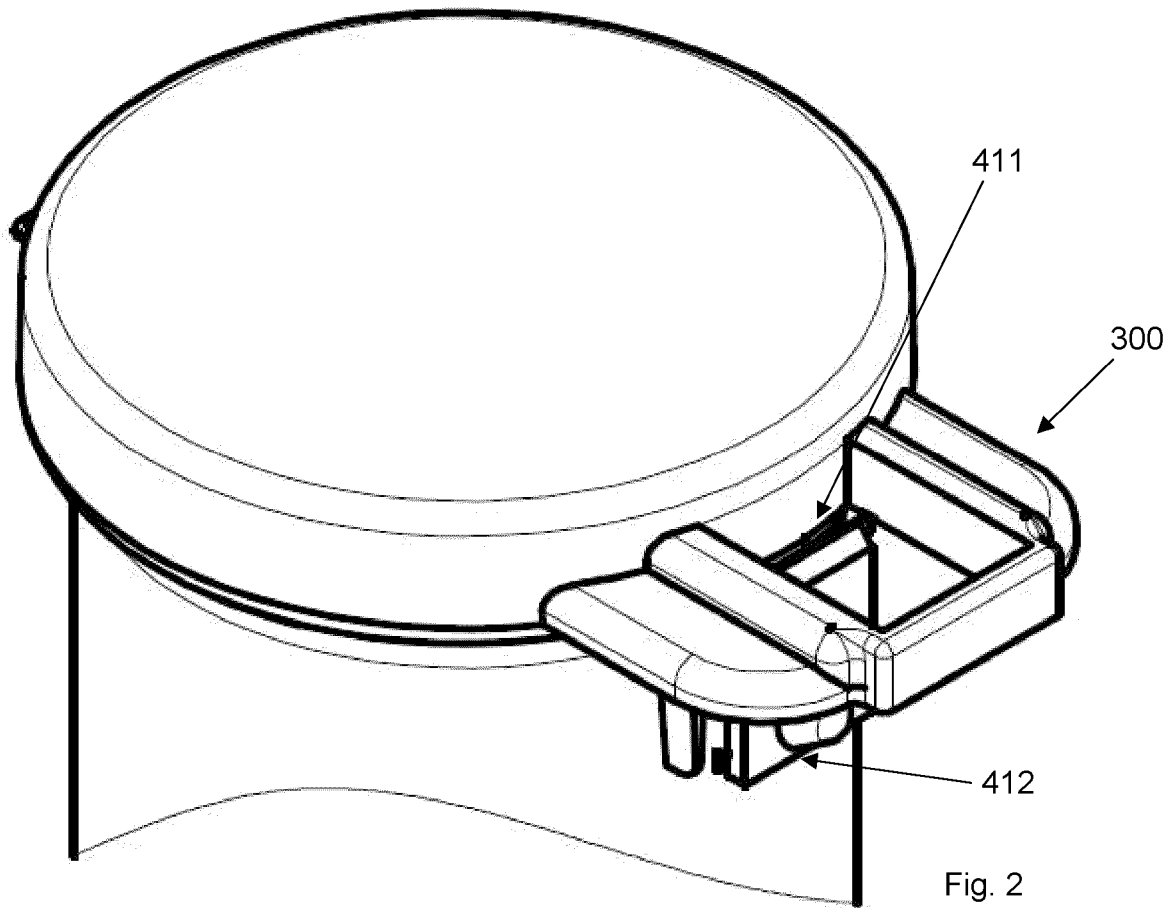

Fig. 1



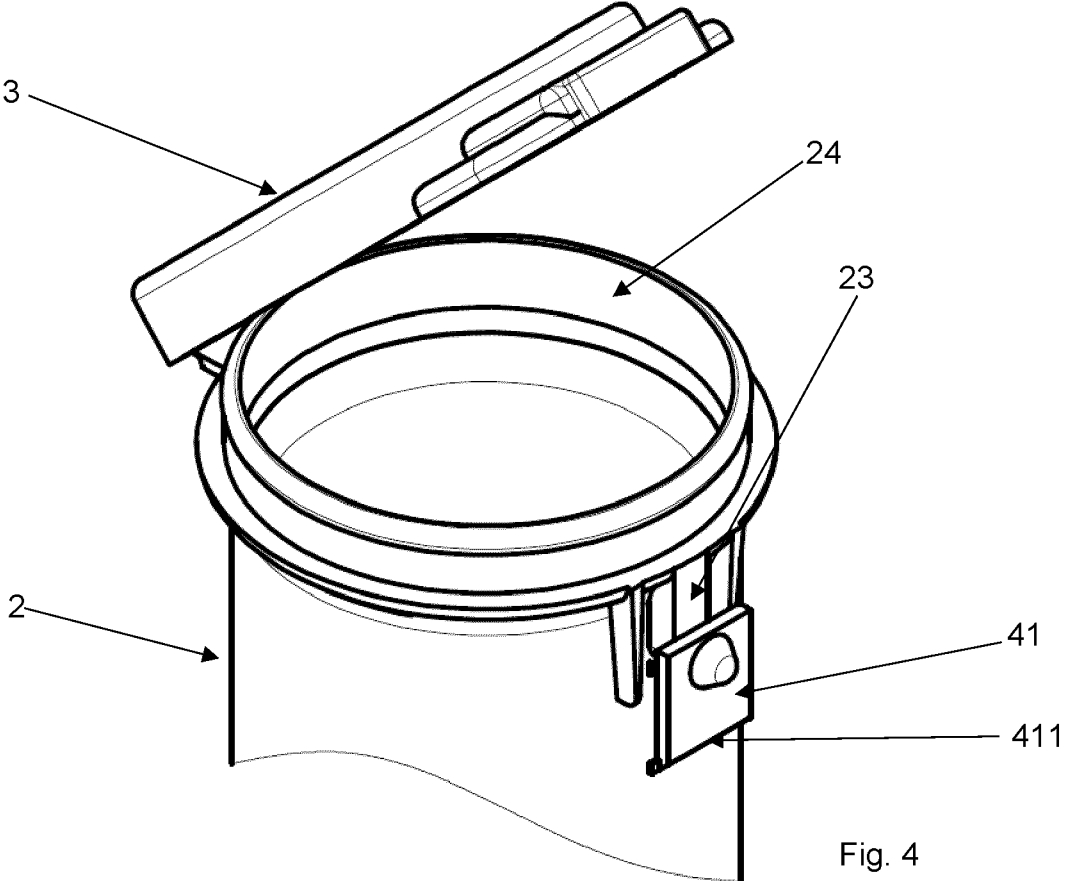

Fig. 4

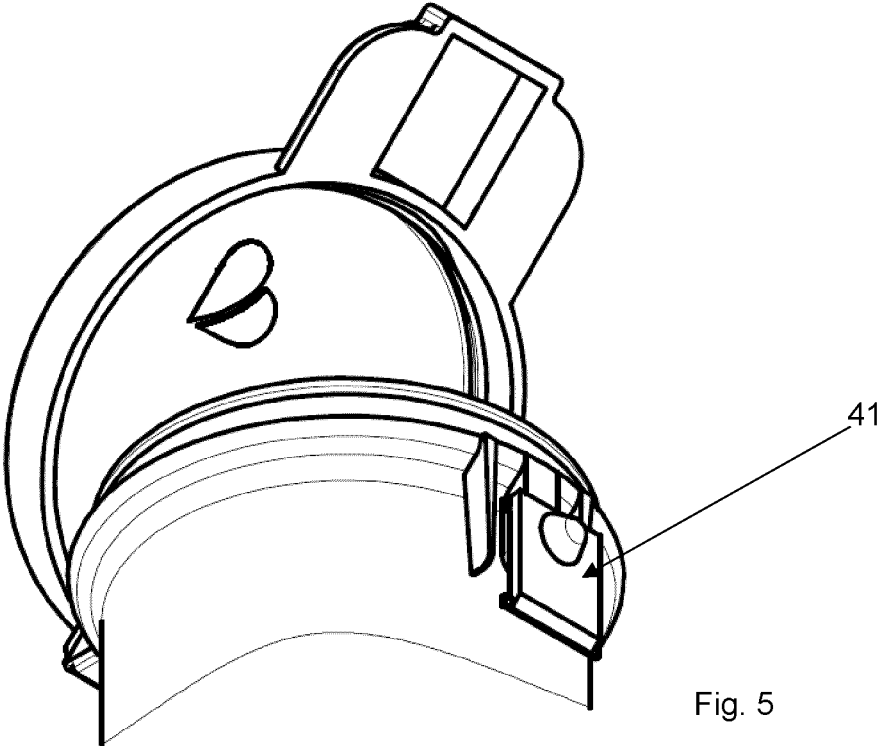

Fig. 5

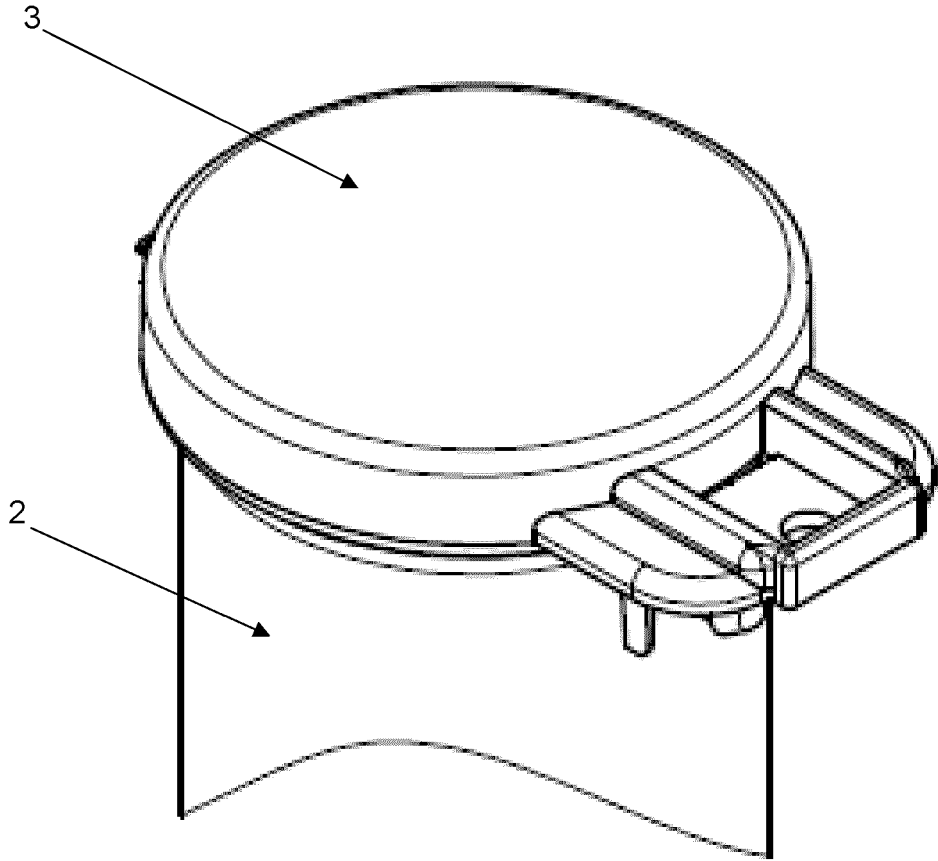

Fig. 6

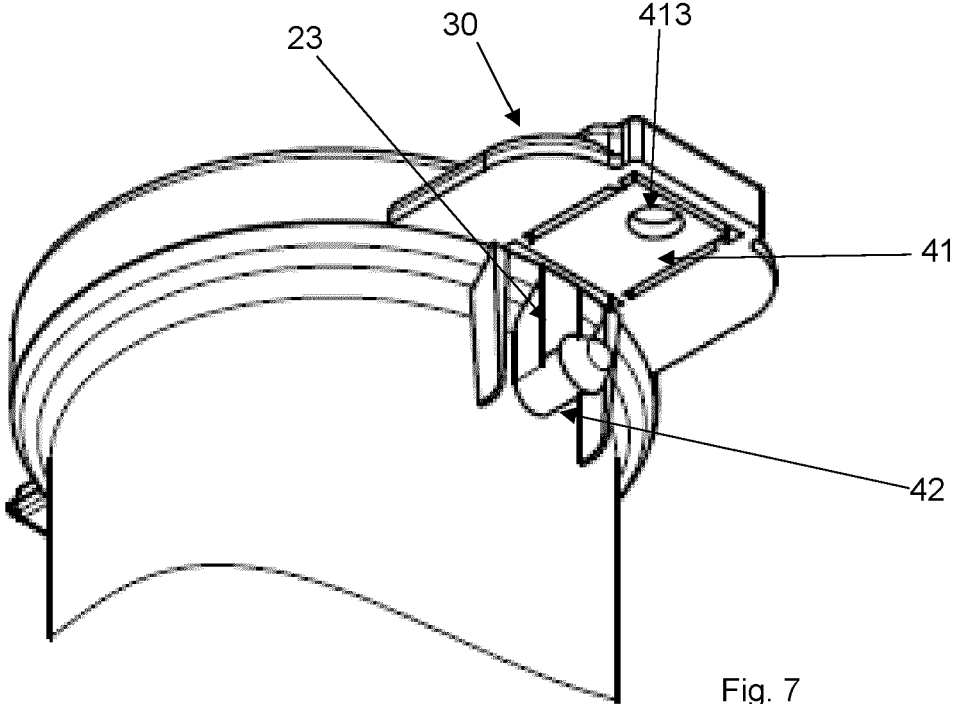

Fig. 7



EUROPEAN SEARCH REPORT

Application Number
EP 24 18 4622

5

10

15

20

25

30

35

40

45

50

55

EPO FORM 1503 03.82 (F04C01)

DOCUMENTS CONSIDERED TO BE RELEVANT			
Category	Citation of document with indication, where appropriate, of relevant passages	Relevant to claim	CLASSIFICATION OF THE APPLICATION (IPC)
A,D	WO 01/44102 A2 (CAPITOL VIAL INC [US]; BELFANCE JOHN [US]; SUPRANOWITZ RONALD [US]) 21 June 2001 (2001-06-21) * page 3, line 16 - line 26; figures 1,4,6 *	1-10	INV. B65D43/16 B65D55/02
A	WO 2008/098327 A1 (VOLLERS CLAUDIO PATRICK [BR]) 21 August 2008 (2008-08-21) * figures 1a, 2a, 3a *	1,9,10	
A	WO 2011/156912 A2 (PATHOGEN DETECTION SYSTEMS INC [CA]; UNIV KINGSTON [CA] ET AL.) 22 December 2011 (2011-12-22) * paragraph [0047] - paragraph [0053]; figures 1,9 *	1,9,10	
A	DE 100 25 265 A1 (SEAQUIST LOEFFLER KUNSTSTOFFWERK GMBH [DE]) 19 July 2001 (2001-07-19) * column 4, line 58 - column 5, line 37; figures 1,2 *	1,9,10	
			TECHNICAL FIELDS SEARCHED (IPC)
			B65D
The present search report has been drawn up for all claims			
Place of search The Hague		Date of completion of the search 12 November 2024	Examiner Bridault, Alain
CATEGORY OF CITED DOCUMENTS X : particularly relevant if taken alone Y : particularly relevant if combined with another document of the same category A : technological background O : non-written disclosure P : intermediate document		T : theory or principle underlying the invention E : earlier patent document, but published on, or after the filing date D : document cited in the application L : document cited for other reasons & : member of the same patent family, corresponding document	

ANNEX TO THE EUROPEAN SEARCH REPORT
ON EUROPEAN PATENT APPLICATION NO.

EP 24 18 4622

5

This annex lists the patent family members relating to the patent documents cited in the above-mentioned European search report. The members are as contained in the European Patent Office EDP file on
The European Patent Office is in no way liable for these particulars which are merely given for the purpose of information.

12-11-2024

10

15

20

25

30

35

40

45

50

55

Patent document cited in search report	Publication date	Patent family member(s)	Publication date
WO 0144102 A2	21-06-2001	AT E398102 T1	15-07-2008
		AU 4707301 A	25-06-2001
		EP 1233924 A2	28-08-2002
		US 6398067 B1	04-06-2002
		US 2002088814 A1	11-07-2002
		WO 0144102 A2	21-06-2001

WO 2008098327 A1	21-08-2008	BR PI0700447 A	07-10-2008
		WO 2008098327 A1	21-08-2008

WO 2011156912 A2	22-12-2011	AU 2011267802 A1	31-01-2013
		BR 112012032347 A2	08-11-2016
		CA 2802115 A1	22-12-2011
		CN 103228554 A	31-07-2013
		EP 2582590 A2	24-04-2013
		ES 2890231 T3	18-01-2022
		JP 5916148 B2	11-05-2016
		JP 2013534883 A	09-09-2013
		KR 20130138715 A	19-12-2013
		SG 186365 A1	30-01-2013
		US 2013177937 A1	11-07-2013
WO 2011156912 A2	22-12-2011		

DE 10025265 A1	19-07-2001	DE 10025265 A1	19-07-2001
		DE 20009203 U1	07-06-2001

EPO FORM P0459

For more details about this annex : see Official Journal of the European Patent Office, No. 12/82

REFERENCES CITED IN THE DESCRIPTION

This list of references cited by the applicant is for the reader's convenience only. It does not form part of the European patent document. Even though great care has been taken in compiling the references, errors or omissions cannot be excluded and the EPO disclaims all liability in this regard.

Patent documents cited in the description

- WO 0144102 A [0002]