

(19)



(11)

EP 4 488 194 A1

(12)

EUROPEAN PATENT APPLICATION

(43) Date of publication:
08.01.2025 Bulletin 2025/02

(51) International Patent Classification (IPC):
B65D 50/06^(2006.01) A24F 23/02^(2006.01)

(21) Application number: **23184288.1**

(52) Cooperative Patent Classification (CPC):
**B65D 50/061; A24F 23/00; B65D 21/0224;
B65D 51/28**

(22) Date of filing: **07.07.2023**

(84) Designated Contracting States:
**AL AT BE BG CH CY CZ DE DK EE ES FI FR GB
GR HR HU IE IS IT LI LT LU LV MC ME MK MT NL
NO PL PT RO RS SE SI SK SM TR**
Designated Extension States:
BA
Designated Validation States:
KH MA MD TN

(71) Applicant: **Holmgrens Plast AB
335 25 Gnosjö (SE)**

(72) Inventor: **HOLMGREN, Stefan
335 32 GNOSJÖ (SE)**

(74) Representative: **AWA Sweden AB
Box 45086
104 30 Stockholm (SE)**

(54) **NON-TOBACCO NICOTINE POUCH CONTAINER AND USE THEREOF**

(57) The present disclosure relates to a non-tobacco nicotine pouch container (1), comprising a first (10) and second (20) part. A side wall (13) of the first part comprises a sealing protrusion (14) and a side wall (23) of the second part comprises a sealing groove (24) complementary to the sealing protrusion and configured to engage with each other when the container is in a closed position. The first part further comprises a first locking protrusion (15) and the side wall of the second part

comprises a plurality of second locking protrusions (25) configured to engage with the first locking protrusion when the container is in the closed position. The first locking protrusion has an opening (16) complementary to one of said second locking protrusions, such that the first and second part are only allowed to be bent apart when the opening is aligned with one of the second locking protrusions.

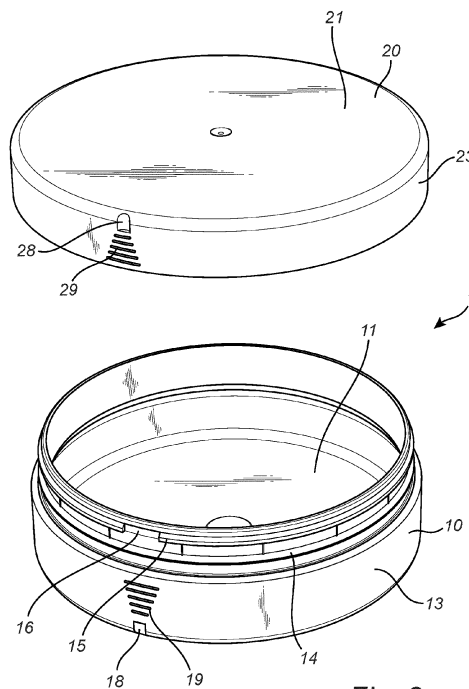

Fig. 3

EP 4 488 194 A1

Description

Technical field

[0001] The present disclosure generally relates to a non-tobacco nicotine pouch container.

Background

[0002] With current trends nicotine pouches are becoming increasingly popular as an alternative to tobacco products. Nicotine pouches are small and discreet pouches that contain nicotine but no tobacco. This product allows consumers to consume nicotine without the need to smoke or use traditional tobacco products. The nicotine pouches are usually bought in different types of containers that are designed to be discrete, portable and convenient. It is important that the container is both easy to bring with and that the container protects the product inside the container. If the nicotine pouches are subject to external elements such as moisture, light and air the quality of the nicotine pouches may be affected.

[0003] Therefore, non-tobacco nicotine pouch containers generally are sized to be fit in a pocket, be easy to open and durable enough to not spill out the pouches. This is usually solved by having cylindrical container that have a base portion and a lid. The base portion and the lid may be snap-fitted together such that the lid seals the base portion when the container is closed, thereby protecting the container from the external elements.

[0004] However, a problem with this type of product is that the container is easy to open which allows children and other unauthorized person to open the container. The usage of nicotine pouches are restricted for individuals below a certain age due to the health risks with the product. It is therefore important to provide a product which provide a safer storage that are more challenging to open than the existing containers.

Summary

[0005] It is therefore an object of the present invention to provide a non-tobacco nicotine pouch container that provides a more responsible storage for nicotine pouches and that is more child secure. Furthermore, it is an object of the present disclosure to provide a non-tobacco nicotine pouch container that are designed to protect the products inside the container, to be portable and easy to close.

[0006] According to a first aspect of the present disclosure, a non-tobacco nicotine pouch container is provided. The non-tobacco nicotine pouch container comprises a first part and a second part each having a base wall with a peripheral edge and a side wall extending from the peripheral edge. The second part is attachable to the first part defining a storage volume when the first part and the second part are attached to each other, thereby defining a closed position of the container. The side wall

of the first part comprises a sealing protrusion extending from the side wall and the side wall of the second part comprises a sealing groove complementary to the sealing protrusion of the first part, wherein, the sealing protrusion and the sealing groove are configured to engage with each other when the container is in the closed position. The first part further comprises a first locking protrusion extending from the side wall and the side wall of the second part comprises a plurality of second locking protrusions configured to engage with the first locking protrusion when the container is in the closed position preventing the container from being opened, and the first locking protrusion has an opening complementary to one of said plurality of second locking protrusions of the side wall of the second part, such that the first part and the second part are only allowed to be bent apart when the opening of the first locking protrusion is aligned with one of the plurality of second locking protrusions.

[0007] The combination of demands on nicotine pouch containers where both the nicotine pouches should be protected from the outer environmental elements and difficult to access for children resulted in the realisation that the nicotine pouch container needs to be both limited in how it may be opened, while still providing some sort of sealing from the outer environment when the nicotine pouch container is in the closed position. This realisation together with that the nicotine pouches needs to be accessible to the customer resulted in a combination of the sealing protrusion and the first locking protrusion. The sealing protrusion of the first part and the groove of the second part extends along the circumference of its respective parts side wall. In other words, the groove and the sealing protrusion extends along the full circumference of its respective part. When the nicotine pouch container is in the closed position, the sealing protrusion and the groove will fit into each other such that the volume of the nicotine pouch container is sealed from outer environmental elements. Thereby, outer environmental elements such as air, moisture and light are not able to affect the quality of the nicotine pouches when the nicotine pouch container is closed. The quality of the nicotine pouches is an important feature for the customers, a constant flow of air or moisture and a constant exposure for light might affect the taste and appearance of the nicotine pouches.

[0008] The first locking protrusion and the plurality of second locking protrusions together provides a child safe locking mechanism. The opening in the first locking protrusion only allows the nicotine pouch container to be opened from the closed position when one of the plurality of second locking protrusions is aligned with the opening of the first locking protrusion. Thereby the second part needs to be moved to the correct position to allow the second part to be bent apart from the first part. Thereby, separating the first part and the second part. When one of the plurality of second locking protrusions is aligned with the opening, the user may bend the second part such that the second locking protrusion aligned with the opening

passes by the opening and out of engagement with the first locking protrusion. Thereby, the second part may be offset from its position such that the other of the plurality of second locking protrusions also loses engagement with the first locking protrusion and the second part may be separated from the first part of the nicotine pouch container. As understood by the skilled person the flexibility of each part of the nicotine pouch container may be designed in correspondence to the design of the first locking protrusion and the plurality of second locking protrusions to allow the first and second part to be bent apart.

[0009] When none of the plurality of second locking protrusions are in alignment with the opening, all of the plurality of second locking protrusions may be in engagement with the first locking protrusion such that the first part and the second part may not be separated. The first and second locking protrusions are designed such that a user may not be allowed to force the first and second part apart by hand, without aligning the opening with one of the plurality of second locking protrusions.

[0010] With the opening being complementary to one of the second locking protrusion is herein meant that the opening has similar shape and size as at least one of the plurality of second locking protrusions. Thereby, in some embodiments the size and shape of each of the plurality of second locking protrusion is similar to each other. Therefore, the first part and the second part are allowed to be bent apart no matter which of the second locking protrusions that is in alignment with the opening in the first locking protrusion. However, it should be noted that the plurality of second locking protrusions may be of different size and shapes in other embodiments.

[0011] It is understood by the skilled person that the first locking protrusion protrude out from the side wall and extends along the full circumference of the side wall except from where the first locking protrusion has the opening. The plurality of second locking protrusions is separated by gaps between them such that each protrusion is not in contact with another second locking protrusion. In some embodiments the gaps are evenly distributed from each other along the circumference of the side wall. In some embodiments the gaps between the second locking protrusions covers a majority of the circumference of the second part. As is understood by the skilled person a second part with lower gap between the second locking protrusion aligned with the opening and the other second locking protrusions requires a more flexible material of the nicotine pouch container to allow the first part to be bent apart and separated from the second part.

[0012] The plurality of second locking protrusions may comprise a release protrusion that is complementary to the opening and wherein the remaining second locking protrusions are larger than the opening, such that the first part and the second part is only allowed to be bent apart when the opening of the first locking protrusion is aligned with the release protrusion.

[0013] By designing the release protrusion such that it differs from the remaining second locking protrusions the

nicotine pouch container may only be allowed to be opened when the release protrusion is aligned with the opening of the first locking protrusion. This further enhance the child safety of the nicotine pouch container as the risk of the first locking protrusion and one of the second locking protrusions accidentally aligning and thereby allowing the nicotine pouch container to be opened is reduced. The design of the remaining second locking protrusions may be altered in shape or size to not be allowed to move through the opening. For example, the extension length along the circumference of the side wall of each of the remaining second locking protrusions may be longer than the length of the opening.

[0014] In some embodiments the remaining of the second locking protrusions may have a smaller gap between each other and a longer gap to the release protrusion, thereby allowing the nicotine pouch container to be produced from a less flexible material.

[0015] The first locking protrusion may be located closer to an open edge of the side wall than the sealing protrusion. This allows the designer to not design the sealing protrusion such that the plurality of second locking protrusions is allowed to pass the sealing protrusion when separating the first part from the part. By positioning the first locking protrusion closer to the open edge of the side wall a more flexible design of the sealing protrusion is allowed.

[0016] The open edge of the side wall is herein meant as the edge of the side wall that is not connected to any other wall. The opposite edge is connected to the peripheral edge of the base wall.

[0017] The plurality of second locking protrusion may be positioned at least 90° from each other. By positioning each second locking protrusion with at least 90° angle to each other an advantageous combination of flexibility and robustness in the material may be achieved. The plurality of second locking protrusion may be positioned 120° from each other. When the release protrusion is included in the plurality of second locking protrusions, the second locking protrusion may have a larger angle to the release protrusion than the angle between two of the second locking protrusions.

[0018] The first locking protrusion of the first part and said plurality of second locking protrusions of the second part may protrude with 0,4-3 mm from the side wall of the first part and the second part. It may be advantageous to design the locking protrusion such that they protrude with the same distance as the engagement surface between the first locking protrusions and said plurality of second locking protrusions are increased which increases the force needed to separate the first part from the second part without aligning the opening with one of the plurality of second locking protrusions.

[0019] The container may made of an elastic material such as plastic, thermoplastic or a polymer material. These materials may provide both the elasticity that is needed by the material to allow the container to be opened as well as being approved for contact with food

products.

[0020] The first part may comprise a first indicator indicating where the opening in the first locking protrusion is located, and the second part may comprise a second indicator indicating where one of said plurality of second locking protrusions is located. With the first and second indicator the user experience of the nicotine pouch container may be improved. The indicators may be small signs that is not obvious for children to spot and align but would be obvious for a customer that have knowledge of the indicators to spot and align. This facilitates the opening process of the nicotine pouch container such that the customer will have an easier time aligning the opening with one of the second locking protrusions.

[0021] In the embodiments where a release protrusion is provided, the second indicator is located at the release protrusion.

[0022] The first and the second indicator may be a respective recess. Recesses are an example of an indicator that is not obvious for children while still being easy to spot for a customer.

[0023] A wall of said plurality of second locking protrusions and a wall of the first locking protrusion that faces each other, when the first part and the second part is moved from an open position to he closed position, may be angled such that the first part and the second part is allowed to be forced to the closed position of the container without aligning the opening and one of said plurality of second locking protrusions.

[0024] By designing the plurality of second locking protrusions and the first locking protrusion such that the walls that faces each other are angled, the first part and the second part is allowed to be forced together to the closed position in any position. Without these angled walls the opening may need to be aligned with one of the plurality of second locking protrusions to allow the nicotine pouch container to be closed. This would require the user to change the relative position of the first part and the second part to misalign the opening from the second locking protrusion to provide the child secure nicotine pouch container, which may be a risk as the user may leave it in a position where it can be opened. By allowing the user to force the first and second part together the opening and the second locking protrusion will be misaligned directly when the nicotine pouch container is in the closed position.

[0025] With angled walls such that the first part and the second part is allowed to be forced to the closed position is herein meant that the angle of the walls is away from each other such that the first locking protrusion and second locking protrusion are allowed to slide pass the wall, when the first part and the second part is in an open position and to be moved to the closed position.

[0026] The first part may further comprise gripping means where the opening in the first locking protrusion is located and wherein the second part may further comprise gripping means located where one of said plurality of second locking protrusions is located. By

providing gripping means at each part the process of opening the nicotine pouch container may be facilitated. The gripping means enhances the grip of the user such that it may be easier to bend the first and second part apart. The gripping means may in some embodiment also substitute the indicators and in other embodiments be combined with the indicators.

[0027] A further scope of applicability of the present invention will become apparent from the detailed description given below. However, it should be understood that the detailed description and specific examples, while indicating preferred embodiments of the invention, are given by way of illustration only, since various changes and modifications within the scope of the invention will become apparent to those skilled in the art from this detailed description.

Brief description of the drawings

[0028] The invention will now be described in more detail with reference to the accompanying drawings.

Fig. 1 illustrates a nicotine pouch container in the closed position.

Fig. 2 illustrates a cross-section of the nicotine pouch container.

Fig. 3 illustrates the nicotine pouch container in an open position.

Fig. 4 illustrates the nicotine pouch container from a perspective view.

Fig. 5 illustrates a second part of the nicotine pouch container.

Detailed description

[0029] The present invention will now be described more fully hereinafter with reference to the accompanying drawings, in which currently preferred embodiments of the invention are shown. This invention may, however, be embodied in many different forms and should not be construed as limited to the embodiments set forth herein; rather, these embodiments are provided for thoroughness and completeness, and to fully convey the scope of the invention to the skilled person.

[0030] In Fig. 1 it is provided a first embodiment of a non-tobacco nicotine pouch container 1. The nicotine pouch container 1 has a cylindrical shape and comprises a first part 10 and a second part 20. In this exemplifying embodiment the first part 10 is a base portion and the second part 20 is a lid portion of the nicotine pouch container 1. The first part 10 has base wall 11 that has a circumferential edge 12 from which a side wall 13 extends. The second part has a base wall 21 that has a circumferential edge 22 from which a side wall 23 extends. The first part 10 and the second part 20 are designed to fit together such that the side wall 23 of the second part 20 encloses the side wall 13 of the first part 10 when the first part 10 and the second part 20 are

attached to each other in a closed position. In the closed position the first part 10 and the second part 20 defines a storage volume 30 that is best seen in Fig. 2. The first part 10 comprises gripping means 19 which are located at a similar position as a first indicator 18. The second part 20 also comprises gripping means 29 located at a similar position as a second indicator 28. The position of the first and second indicator 18, 28 and the gripping means 19, 29 will be further discussed in connection to Fig. 2-4. The gripping means 19, 29 is provided to facilitate the process of opening the nicotine pouch container 1. The first indicator 18 and the second indicator 28 is shaped as recess in the first part 10 and the second part 20. In Fig. 1 the first indicator 18 and the second indicator 28 is not aligned with each other. Recesses are an example of an indicator that is not obvious for children while still being easy to spot for a customer. The nicotine pouch container 1 is made of an elastic material such as plastic, thermoplastic or a polymer material. The material needs to both provide elasticity to the nicotine pouch container 1 to facilitate to opening process as well as being approved for contact with food products.

[0031] Turning to Fig. 2-5 different views of the design of the nicotine pouch is illustrated. In Fig. 2 the nicotine pouch container 1 is illustrated in the closed position in a cross-sectional view. In Fig. 3 the nicotine pouch container 1 is illustrated in an open position at a perspective view from above to better disclose the first part 10. In Fig. 4 the nicotine pouch container 1 is illustrated in an open position at a perspective view from below to better disclose the second part 20. In Fig. 5 the second part 20 is illustrated viewing the inside of the second part 20.

[0032] The first part 10 and the second part 20 is attached to each other and the volume 30 defined by the side walls 13, 23 and the base walls 11, 21 of the first and second part 10, 20 is clearly illustrated in the cross-section of Fig. 2. This volume 30 is used for storing nicotine pouches. The cross-sectional view discloses that the side wall 13 of the first part 10 comprises a sealing protrusion 14 extending from the side wall 13 and that the side wall 23 of the second part 20 comprises a sealing groove 24 that is complementary to the sealing protrusion 14 of the first part 10. The sealing protrusion 14 and the sealing groove 24 are configured to engage with each other when the nicotine pouch container 1 is in the closed position. The sealing protrusion 14 extends into and fits in the sealing groove 24 which result in a sealing that seals of the external environment such as air, moisture, and light from the volume 30. The sealing protrusion 14 of the first part 10 and the sealing groove 24 of the second part 20 extends along the length of its respective parts side wall 13, 23. In other words, the sealing groove 24 and the sealing protrusion 14 extends along the full circumference of its respective part 10, 20. Thereby the sealing protrusion 14 and the sealing groove 24 are able to generally isolate the volume 30 from the outer environment when the nicotine pouch container 1 is in the closed position.

[0033] The first part 10 further comprises a first locking protrusion 15 extending from the side wall 13 and located closer to an open edge 17 of the side wall 13 than the sealing protrusion 14. The open edge 17 of the side wall 13 is herein meant as the edge of the side wall 13 that is not connected to any other wall. The opposite edge to the open edge 17 is connected to the peripheral edge 12 of the base wall 11. The side wall 23 of the second part 20 further comprises a plurality of second locking protrusions 25 configured to engage with the first locking protrusion 15 when the nicotine pouch container 1 is in the closed position preventing the container 1 from being opened. The first locking protrusion 15 of the first part 10 and said plurality of second locking protrusions 25 of the second part 20 protrude with 0,4-3 mm from the side wall 13, 23 of the first part 10 and the second part 20. It may be advantageous to design the first and second locking protrusions 15, 25 such that they protrude with the same distance, as the engagement surface between the first locking protrusions 15 and said plurality of second locking protrusions 25 are increased which increases the force needed to separate the first part 10 from the second part 20.

[0034] The first locking protrusion 15 comprises an opening 16. The opening 16 in the first locking protrusion 15 is best seen in Fig. 3 and 4. The plurality of second locking protrusions 25 comprises a release protrusion 26 that is complementary to the opening 16 of the first locking protrusion 15. The remaining second locking protrusions 25 are larger than the opening 16, such that the first part 10 and the second part 20 is only allowed to be bent apart when the opening 16 of the first locking protrusion 15 is aligned with the release protrusion 26. If the opening 16 is aligned with one of the remaining of the plurality of second locking protrusions 25 it will not be possible to separate the first part 10 from the second part 20 as the remaining of the second locking protrusions are not allowed to pass through due to the circumferential extension of the second locking protrusions 25. In this embodiment the plurality of locking protrusions 25, except for the release protrusion 26, have a longer circumferential extension than the opening 16. As is understood by the skilled person, this implies that the release protrusion 26 has a shorter circumferential extension than the remaining second locking protrusions 25 and is matched to fit through the opening 16. The difference of the release protrusion 26 and the second locking protrusions 25 may be best seen in Fig. 5, where a release protrusion 26 and two of the second locking protrusion 25 is illustrated. However, in other embodiments it may be other features, such as the shape of the release protrusion 26 and the opening 16, which is adapted to provide a similar effect. By designing the release protrusion 26 such that it differs from the remaining second locking protrusions 25 the nicotine pouch container 1 may only be allowed to be opened when the release protrusion 26 is aligned with the opening 16 of the first locking protrusion 15. This further enhance the child safety of the nicotine pouch container 1

as the risk of the opening 16 and the release protrusion 26 accidentally aligning and thereby allowing the nicotine pouch container 1 to be opened is reduced. The first locking protrusion 15 protrude out from the side wall 13 and extends along the full circumference of the side wall 13 except from where the first locking protrusion 15 has the opening 16. The plurality of second locking protrusions 25 is separated by gaps between them such that each protrusion is not in contact with each other. In some embodiments the remaining of the second locking protrusions 25 may have a smaller gap between each other and a longer gap to the release protrusion 26, thereby allowing the nicotine pouch container 1 to be produced from a less flexible material. The circumferential extension of the second locking protrusions 25 may be varied depending on how challenging the nicotine pouch container 1 should be to open. If the second locking protrusion 25 covers a bigger length of the circumference, the engagement between the second locking protrusions 25 and the first locking protrusion 15 will be larger and therefore a greater force would be needed to separate the first part 10 from the second part 20. This may however be mitigated by altering the flexibility of the material.

[0035] The first locking protrusion 15 and the plurality of second locking protrusions 25 provides together a child safe locking mechanism. When the release protrusion 25 is not in alignment with the opening 16, all of the plurality of second locking protrusions 24 is in engagement with the first locking protrusion 15 such that the first part 10 and the second part 20 may not be separated. The first and second locking protrusions 15, 25 are designed such that a user may not be allowed to force the first 10 and second part 20 apart by hand, without first aligning the opening 16 with the release protrusion 26. The engagement between the first locking protrusion 15 and one of the second locking protrusions 25 is best seen in the enlarged view of Fig. 2.

[0036] The opening 16 in the first locking protrusion 15 only allows the nicotine pouch container 1 to be opened from the closed position when the release protrusion 26 is aligned with the opening 16 of the first locking protrusion 15. Thereby the second part 20 needs to be rotated to the correct position to allow the second part 20 to be bent apart from the first part 10. As is understood by the skilled person, this opening process is a combination of the opening 16 allowing the release protrusions 26 to slide through, the flexibility of the material and the gap between the release protrusion 26 to the closest of the plurality of second locking protrusions 25. If the gap is smaller a more flexible material is needed to be used to allow the second part 20 to be bent off. When the release protrusion 26 slides through the opening 16, the second part is offset from its position such that the remaining of the plurality of second locking protrusions 25 also losses engagement with the first locking protrusion 15 and the second part 20 may be separated from the first part 10 of the nicotine pouch container 1.

[0037] To facilitate the opening process the first part 10

and the second part 20 may comprise indicators and/or gripping means. As mentioned in connection to Fig. 1, the first part 10 further comprises a first indicator 18 where the opening 16 in the first locking protrusion 15 is located.

5 The second part 20 further comprises a second indicator 28 located where the release protrusion 26 is located. The indicators may be small visual signs that are not obvious for children to spot and align but would be obvious for a customer that have knowledge of the indicators to spot and align. This facilitates the opening process of the nicotine pouch container 1 such that the customer will have an easier time aligning the opening 16 with the release protrusion 26. As the nicotine pouch container 1 usually do not allow the user to see through it, the indicators may be improving the user experience.

[0038] The first part 10 further comprises gripping means 19 where the opening 16 in the first locking protrusion 15 is located. The second part 20 further comprises gripping means 29 located where the release protrusion 26 is located. The gripping means 19, 29 enhances the grip of the user such that it may be easier to bend the first 10 and second part 20 apart. The gripping means 19, 29 are as described also located such that they align when the opening 16 and the release protrusion 26 align to enhance the grip when the first part 10 is bent apart from the second part 20. The gripping means 19, 29 may in some embodiment also substitute the indicators 18, 28.

[0039] A wall 25a of said plurality of second locking protrusions 25 and a wall 15a of the first locking protrusion 15 that faces each other, when the first part 10 and second part 20 is to be moved from an open position to the closed position, is angled such that the first part 10 and the second part 20 is allowed to be forced to the closed position of the container 1 without aligning the opening 16 and the release protrusion 26. By designing the plurality of second locking protrusions 25 and the first locking protrusion 15 such that the walls that faces each other, when the first part 10 and second part 20 is to be moved from an open position to the closed position, are angled, the first part 10 and the second part 20 is allowed to be forced together to the closed position from any position. This may be seen as a snap-fit solution. Without these angled walls the opening 16 may need to be aligned with the release protrusion 26 to allow the nicotine pouch container 1 to be closed. This would require the user to change the relative position of the first part 10 and the second part 20 to misalign the opening 16 from the release protrusion 26 to lock the nicotine pouch container 1, which may be a risk as the user may leave it in a position where it can be opened. By allowing the user to force the first and second part 10, 20 together the opening 16 and the release protrusion 26 will be misaligned directly when the nicotine pouch container 1 is forced to the closed position. These walls are best seen in the enlarged view in Fig. 2.

[0040] The container according to the above may be provided for storing non-tobacco nicotine pouches.

Further, the container according to the above may be used for storing non-tobacco nicotine pouches.

[0041] The person skilled in the art realizes that the present invention by no means is limited to the preferred embodiments described above. On the contrary, many modifications and variations are possible within the scope of the appended claims.

[0042] Additionally, variations to the disclosed embodiments can be understood and effected by the skilled person in practicing the claimed invention, from a study of the drawings, the disclosure, and the appended claims.

Claims

1. A non-tobacco nicotine pouch container (1), comprising;

a first part (10) and a second part (20) each having a base wall (11, 21) with a peripheral edge (12, 22) and a side wall (13, 23) extending from the peripheral edge,

wherein the second part is attachable to the first part defining a storage volume (30) when the first part and the second part are attached to each other, thereby defining a closed position of the container,

wherein the side wall of the first part comprises a sealing protrusion (14) extending from the side wall and the side wall of the second part comprises a sealing groove (24) complementary to the sealing protrusion of the first part, wherein, the sealing protrusion and the sealing groove are configured to engage with each other when the container is in the closed position,

wherein the first part further comprises a first locking protrusion (15) extending from the side wall and the side wall of the second part comprises a plurality of second locking protrusions (25) configured to engage with the first locking protrusion when the container is in the closed position preventing the container from being opened, and

wherein the first locking protrusion has an opening (16) complementary to one of said plurality of second locking protrusions of the side wall of the second part, such that the first part and the second part are only allowed to be bent apart when the opening of the first locking protrusion is aligned with one of the plurality of second locking protrusions.

2. The container according to claim 1 wherein the plurality of second locking protrusions comprises a release protrusion (26) that is complementary to the opening and wherein the remaining second locking protrusions are larger than the opening, such that the first part and the second part is only allowed to be

bent apart when the opening of the first locking protrusion is aligned with the release protrusion.

3. The container according to claim 1 or 2, wherein the first locking protrusion is located closer to an open edge (17) of the side wall than the sealing protrusion.
4. The container according to any one of the preceding claims wherein the first locking protrusion of the first part and said plurality of second locking protrusions of the second part protrudes with 0,4-3 mm from the side wall of the first part and the second part.
5. The container according to any one of the preceding claims wherein the container is made of an elastic material such as plastic, thermoplastic or a polymer material.
6. The container according to any one of the preceding claims, wherein the first part comprises a first indicator (18) indicating where the opening in the first locking protrusion is located and wherein the second part comprises a second indicator (28) indicating where one of said plurality of second locking protrusions is located.
7. The container according to claim 7, wherein the first and the second indicators are a respective recess.
8. The container according to any one of the preceding claims, wherein a wall (15a) of said plurality of second locking protrusions and a wall (25a) of the first locking protrusion that faces each other, when the first part and the second part is moved from an open position to the closed position, are angled such that the first part and the second part is allowed to be forced to the closed position of the container without aligning the opening and one of said plurality of second locking protrusions.
9. The container according to any one of the preceding claims, wherein the first part further comprises gripping means (19) where the opening in the first locking protrusion is located and wherein the second part further comprises gripping means (29) located where one of said plurality of second locking protrusions is located.
10. Providing of the container according to any one of claims 1-9 for storing non-tobacco nicotine pouches.
11. Use of the container according to any one of claims 1-9 for storing non-tobacco nicotine pouches.

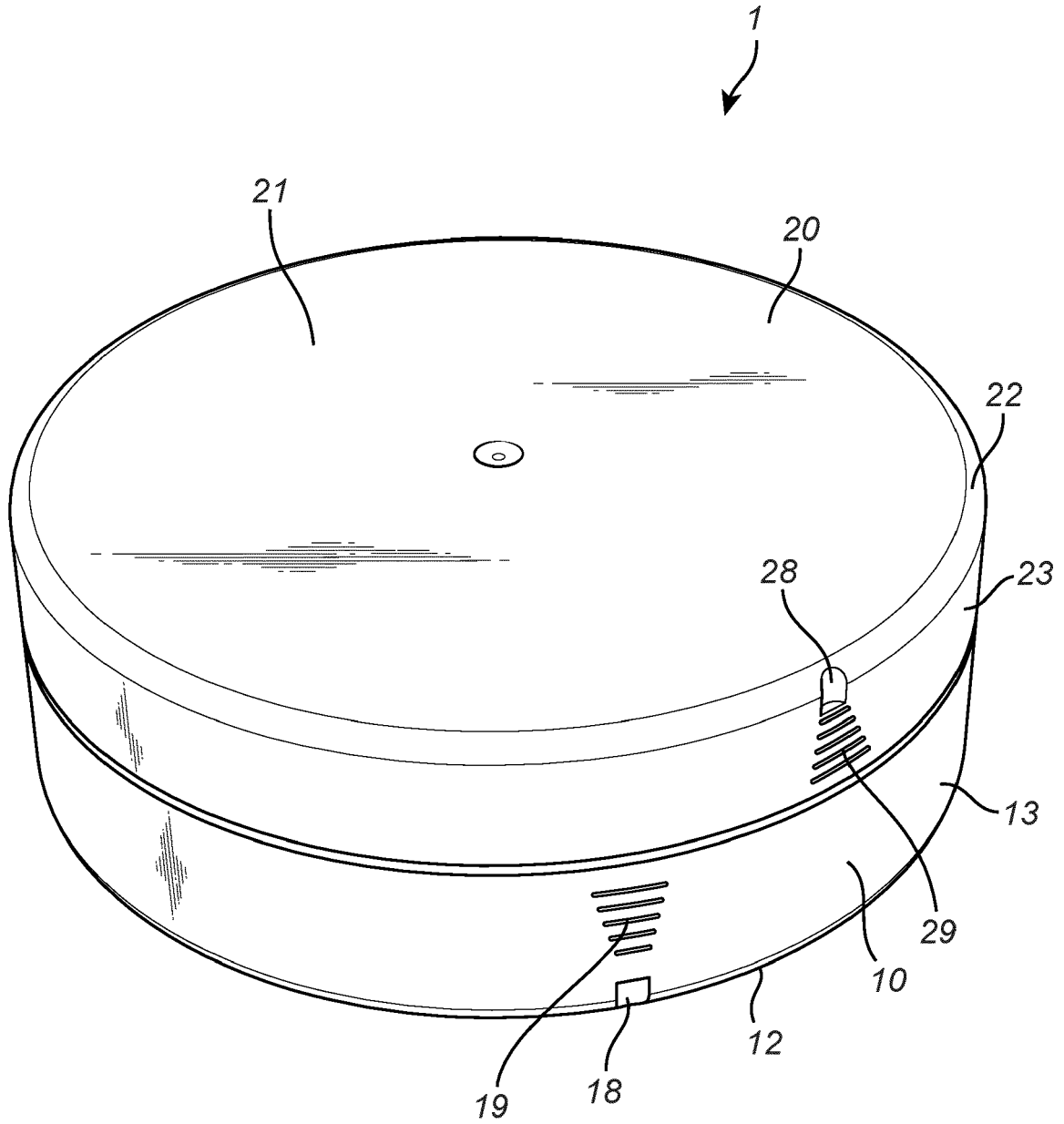

Fig. 1

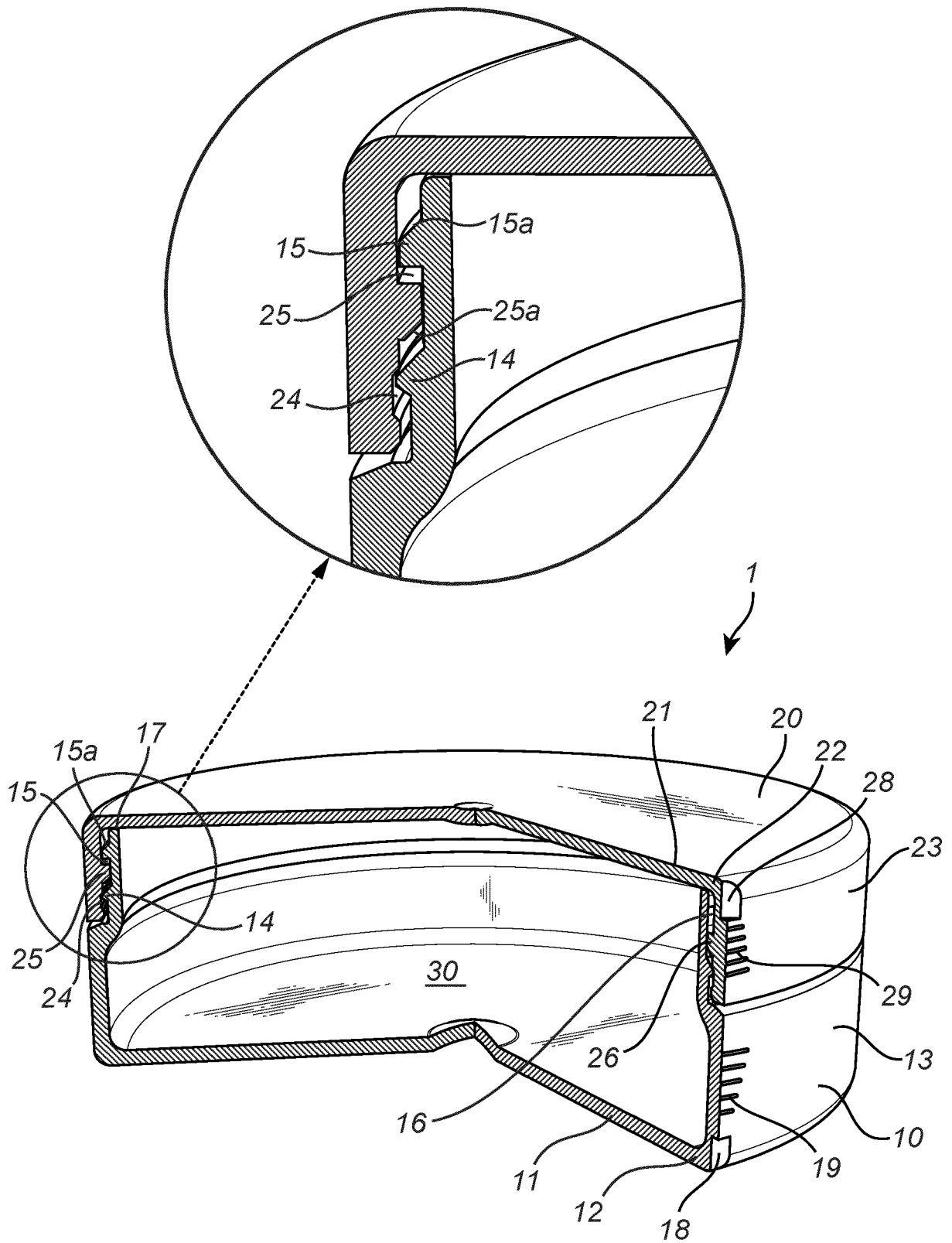

Fig. 2

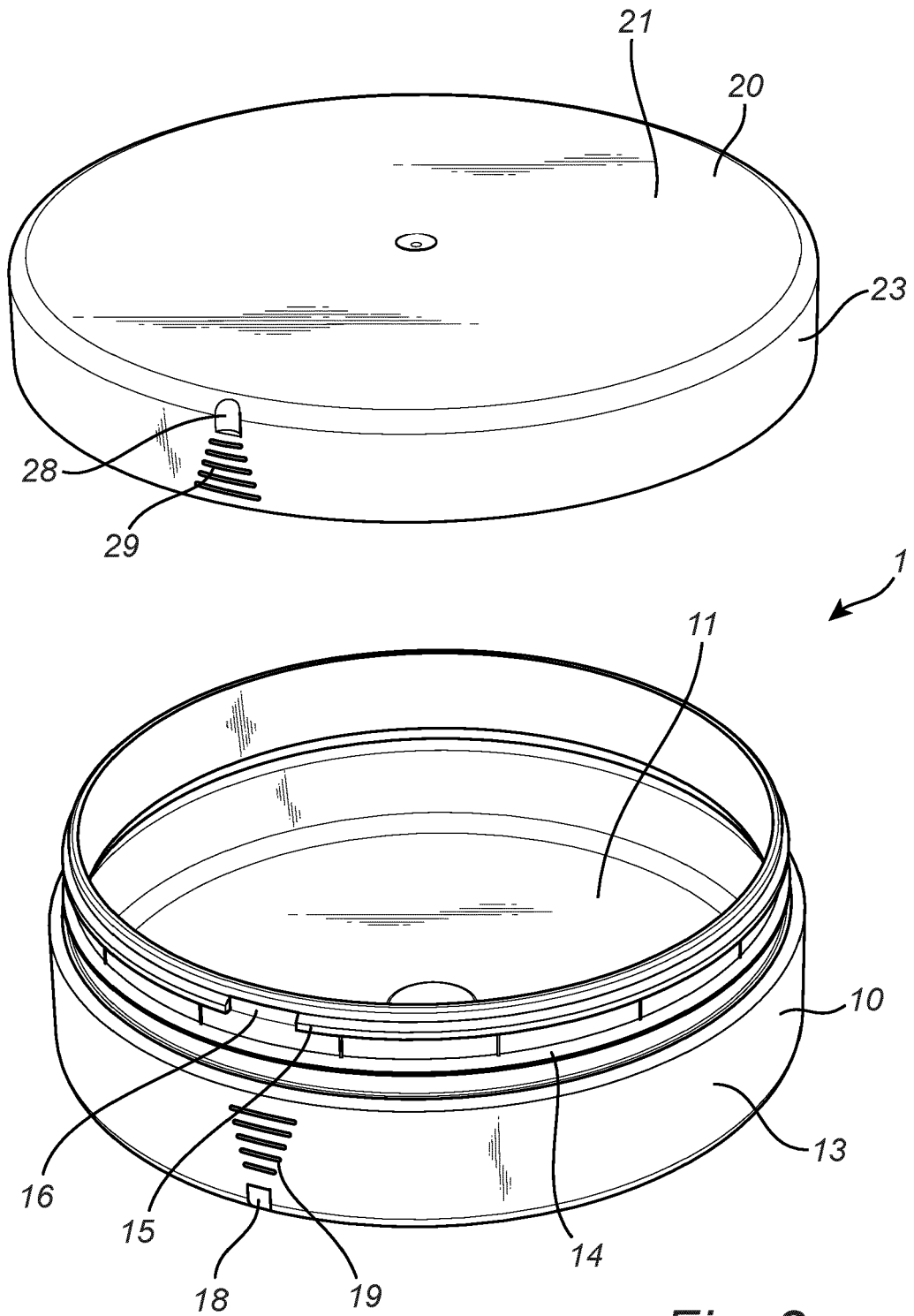

Fig. 3

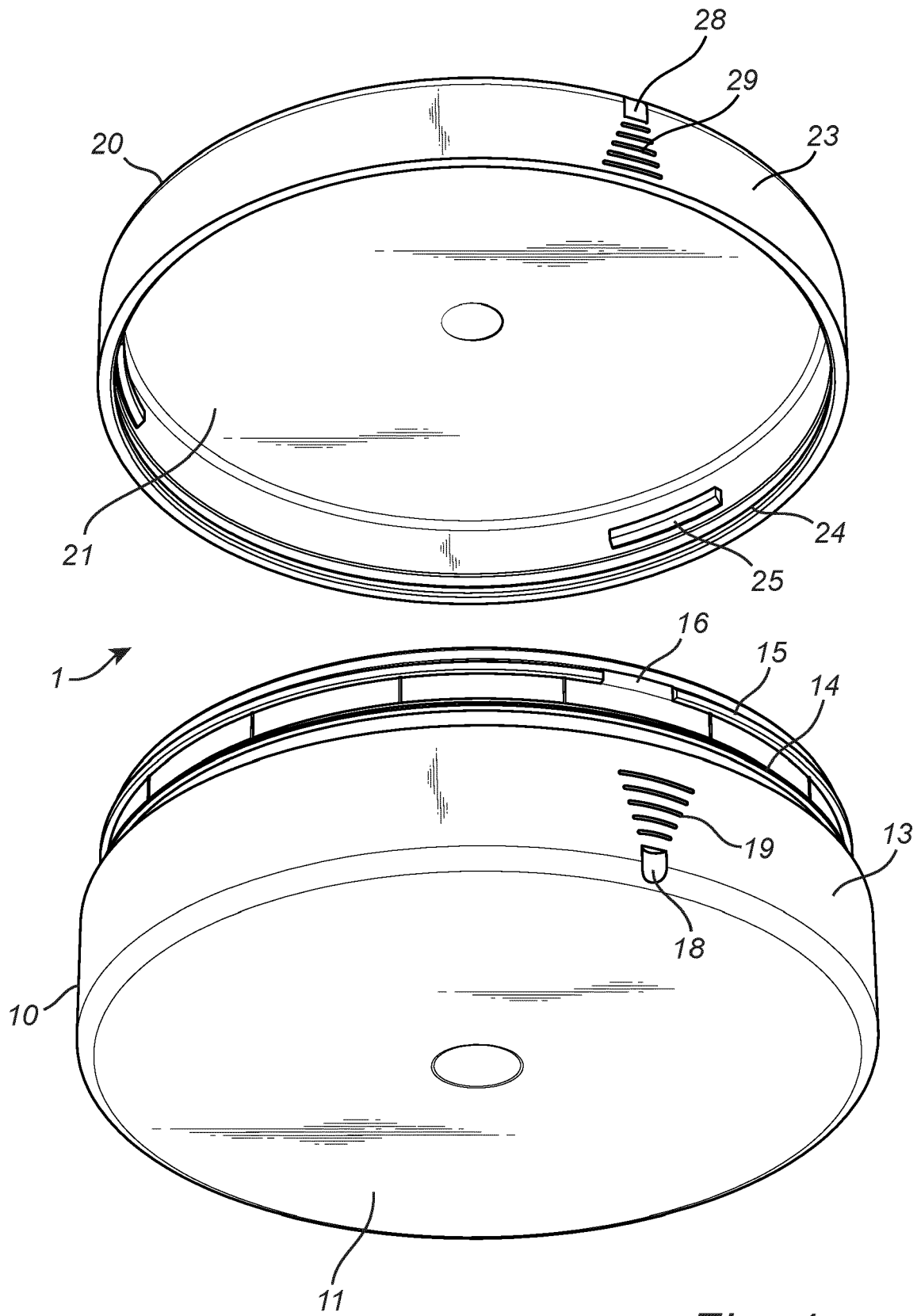

Fig. 4

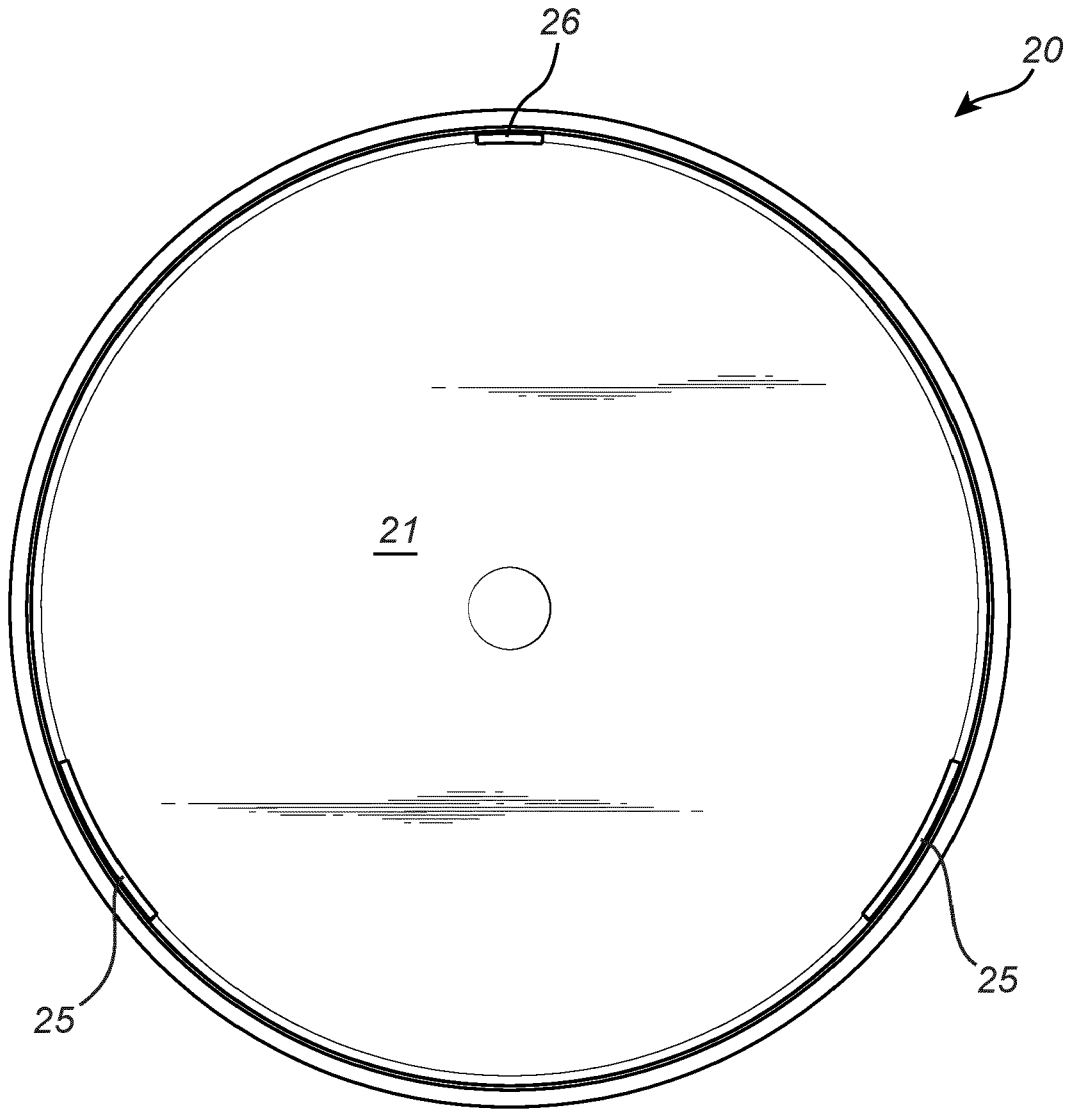

Fig. 5



EUROPEAN SEARCH REPORT

Application Number
EP 23 18 4288

5

10

15

20

25

30

35

40

45

50

55

DOCUMENTS CONSIDERED TO BE RELEVANT			
Category	Citation of document with indication, where appropriate, of relevant passages	Relevant to claim	CLASSIFICATION OF THE APPLICATION (IPC)
X	US 2021/009323 A1 (MARKARIAN MICHAEL [US] ET AL) 14 January 2021 (2021-01-14) * page 2, paragraph 37 - page 5, paragraph 83 * * figures 1-12B *	1-11	INV. B65D50/06 A24F23/02
A	US 5 826 738 A (MINH DO LE [US]) 27 October 1998 (1998-10-27) * column 2, line 47 - column 6, line 60 * * figures 1-13 *	1, 8, 10, 11	
A	WO 2017/125405 A1 (SWEDISH MATCH NORTH EUROPE AB [SE]) 27 July 2017 (2017-07-27) * page 16, line 1 - page 21, line 28 * * figures 1-7 *	1, 10, 11	
			TECHNICAL FIELDS SEARCHED (IPC)
			B65D A24F
The present search report has been drawn up for all claims			
Place of search Munich		Date of completion of the search 11 December 2023	Examiner Piolat, Olivier
CATEGORY OF CITED DOCUMENTS		T : theory or principle underlying the invention E : earlier patent document, but published on, or after the filing date D : document cited in the application L : document cited for other reasons & : member of the same patent family, corresponding document	
X : particularly relevant if taken alone Y : particularly relevant if combined with another document of the same category A : technological background O : non-written disclosure P : intermediate document			

1
EPO FORM 1503 03.82 (P04C01)

ANNEX TO THE EUROPEAN SEARCH REPORT
ON EUROPEAN PATENT APPLICATION NO.

EP 23 18 4288

5

This annex lists the patent family members relating to the patent documents cited in the above-mentioned European search report. The members are as contained in the European Patent Office EDP file on The European Patent Office is in no way liable for these particulars which are merely given for the purpose of information.

11-12-2023

10

Patent document cited in search report	Publication date	Patent family member(s)	Publication date
US 2021009323 A1	14-01-2021	CA 3083922 A1 US 2021009323 A1	17-12-2020 14-01-2021

US 5826738 A	27-10-1998	NONE	

WO 2017125405 A1	27-07-2017	CA 3008974 A1 DK 3405050 T3 EP 3405050 A1 JP 6865747 B2 JP 2019509713 A KR 20180102538 A RU 2018115305 A US 2018319556 A1 WO 2017125405 A1	27-07-2017 02-06-2020 28-11-2018 28-04-2021 11-04-2019 17-09-2018 20-02-2020 08-11-2018 27-07-2017

15

20

25

30

35

40

45

50

55

EPO FORM P0459

For more details about this annex : see Official Journal of the European Patent Office, No. 12/82