

(19)



(11)

**EP 4 506 271 A1**

(12)

**EUROPEAN PATENT APPLICATION**

(43) Date of publication:  
**12.02.2025 Bulletin 2025/07**

(51) International Patent Classification (IPC):  
**B65D 1/26** (2006.01) **B65D 3/06** (2006.01)  
**B65D 71/14** (2006.01) **B65D 23/08** (2006.01)  
**B65D 77/20** (2006.01)

(21) Application number: **24189099.5**

(22) Date of filing: **17.07.2024**

(52) Cooperative Patent Classification (CPC):  
**B65D 71/14; B65D 1/265; B65D 3/06;**  
**B65D 23/0814; B65D 77/20**

(84) Designated Contracting States:  
**AL AT BE BG CH CY CZ DE DK EE ES FI FR GB**  
**GR HR HU IE IS IT LI LT LU LV MC ME MK MT NL**  
**NO PL PT RO RS SE SI SK SM TR**

Designated Extension States:  
**BA**

Designated Validation States:  
**GE KH MA MD TN**

(72) Inventors:  
• **Millspaw, Micah Roger**  
**Oconomowoc (US)**  
• **Stowers, Mark David**  
**Lancaster (US)**

(74) Representative: **Barker Brettell LLP**  
**100 Hagley Road**  
**Edgbaston**  
**Birmingham B16 8QQ (GB)**

(30) Priority: **08.08.2023 US 202318366995**

(71) Applicant: **Silgan Containers LLC**  
**Woodland Hills, California 91367 (US)**

(54) **METAL SHOT CUP**

(57) Various embodiments of a metal container, such as a shot cup are described. The metal shot cup includes a body with a tightly curled rim at the top end of the cup. The body includes multiple tapered sections such that the diameter of the cup may be different at different places along a height of the cup. In various embodiments, the metal shot cup includes a polymer coating on at least one of the interior and exterior surfaces.

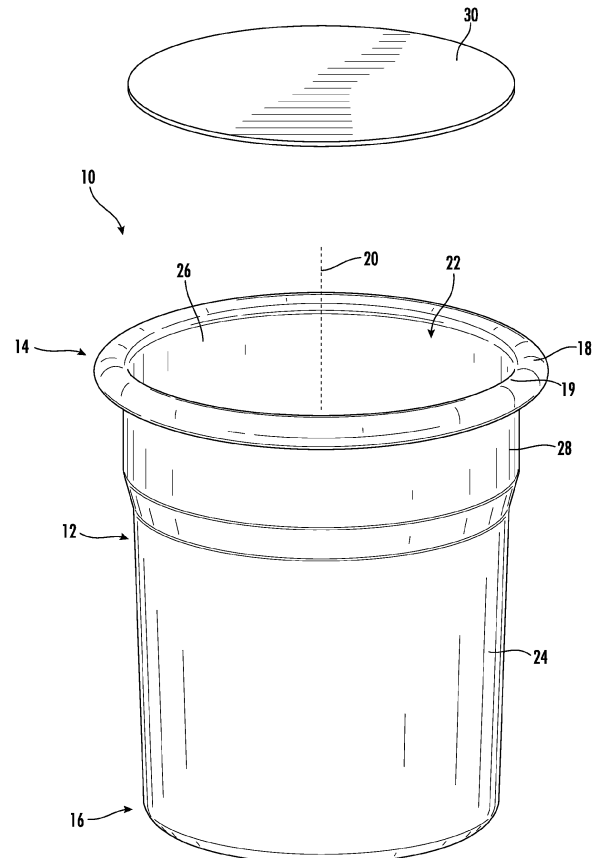

**FIG. 1**

**EP 4 506 271 A1**

## Description

### BACKGROUND OF THE INVENTION

**[0001]** The present invention relates generally to the field of metal containers. The present invention relates specifically to a metal shot cup. A typical shot cup is frequently fabricated from plastic and is designed to contain liquid. However, plastic shot cups are designed for single use. The production of such plastic cups not only creates carbon dioxide emissions, but also potentially negatively impacts the environment because a large proportion of plastic cups are sent to landfills and may end up adding to pollution of the environment. Additionally, some plastic cups are produced with chemicals (e.g., BPA) that may cause adverse health conditions in people who drink from the cups. Given the negative environmental and health impacts associated with single use plastic cups, metal would be a more desirable material from which to manufacture a reusable shot cup.

**[0002]** Furthermore, it is not just the use of metal which is important, it is also the selection of the metal and particular configuration changes from a typical plastic container which are important. In particular, the container must be configured to permit high speed, economical manufacturing, configured to permit dense packing for shipping, and configured to include a similar volume and/or have a volume indicator associated with the typical volume of liquid in a shot cup. In addition to the particular metal and configuration selection, the selection of coating for the container is also important because it affects the manufacturability of the container, the handling of the container and the impact of the container on the contained liquid.

### SUMMARY OF THE INVENTION

**[0003]** One embodiment of the invention relates to a metal shot cup. The shot cup includes a first end and a second end that opposes the first end of the shot cup. The shot cup further includes a circular rim extending between an outside edge and an inside edge centered on a longitudinal axis. The circular rim has a radius less than .05 inches. The shot cup has a sidewall extending between the first end and the second end of the shot cup, the sidewall is centered on the longitudinal axis. The sidewall includes an exterior surface, an interior surface, and a plurality of tapered sections. The tapered sections extend between the first end and the second end of the shot cup. The shot cup includes a bottom with a circular surface generally parallel to the circular rim and centered on the longitudinal axis, the circular surface connects to a trough at an outside edge of the circular surface. The shot cup further includes a polymer coating on at least a portion of the sidewall.

**[0004]** Another embodiment of the invention relates to a one-piece metal shot cup. The shot cup includes an open end with a bore and a closed end that opposes the

open end of the shot cup. The shot cup further includes a rim extending between an outside edge and an inside edge centered on a longitudinal, central axis. The shot cup has a sidewall extending between the open end and the closed end of the shot cup, the sidewall is centered on the longitudinal, central axis. The sidewall includes an exterior surface, an interior surface, a first tapered section, a second tapered section, and an upper section. The first tapered section extends at a first angle relative to the longitudinal, central axis. The second tapered section extends at a second angle relative to the longitudinal, central axis. The shot cup further includes a bottom with a circular surface generally parallel to the rim and centered on the longitudinal, central axis. The circular surface connects to a trough at an outside edge of the circular surface. The first tapered section is positioned between the bottom and the second tapered section. The upper section is positioned between the second tapered section and the rim.

**[0005]** Another embodiment of the invention relates to a one-piece metal shot cup kit. The one-piece metal shot cup kit includes a plurality of one-piece metal shot cups. Each one-piece metal shot cup includes an open end with a central bore and a closed end opposing the open end of the shot cup. The one-piece metal shot cup includes a circular rim extending between an outside edge and an inside edge centered on a longitudinal axis. The circular rim has a radius less than .05 inches. Each one-piece metal shot cup includes an exterior surface, an interior surface, and a plurality of tapered sections extending between the open end and the closed end. The plurality of tapered sections each extend at an angle relative to the longitudinal axis. Each one-piece metal shot cup further includes a bottom with a circular surface generally parallel to the circular rim and centered on the longitudinal axis. The circular surface connects to a trough at an outside edge of the circular surface. The one-piece metal shot cup kit further includes a container configured to hold the plurality of one-piece metal shot cups when the plurality of one-piece metal shot cups are stacked.

**[0006]** Additional features and advantages will be set forth in the detailed description which follows, and will be readily apparent to those skilled in the art from the description or recognized by practicing the embodiments as described in the written description and/or shown in the accompany drawings. It is to be understood that both the foregoing general description and the following detailed description are exemplary.

**[0007]** The accompanying drawings are included to provide further understanding and are incorporated in and constitute a part of this specification. The drawings illustrate one or more embodiments and, together with the description, serve to explain principles and operation of the various embodiments. In addition, alternative exemplary embodiments relate to other features and combinations of features as may be generally recited in the claims.

## BRIEF DESCRIPTION OF THE DRAWINGS

**[0008]** This application will become more fully understood from the following detailed description, taken in conjunction with the accompanying figures, wherein like reference numerals refer to like elements in which:

FIG. 1 is a perspective view of a metal shot cup, according to an exemplary embodiment.

FIG. 2 is a front side view of the metal shot cup of FIG. 1.

FIG. 3 is a rear side view of the metal shot cup of FIG. 1.

FIG. 4 is a right side view of the metal shot cup of FIG. 1.

FIG. 5 is a left side view of the metal shot cup of FIG. 1.

FIG. 6 is a top view of the metal shot cup of FIG. 1.

FIG. 7 is a bottom view of the metal shot cup of FIG. 1.

FIG. 8 is a cross-sectional view of the metal shot cup taken along line 8-8 in FIG. 5.

FIG. 9 is a perspective view of a stack of the metal shot cups of FIG. 1, according to an exemplary embodiment.

FIG. 10 is a packaging for metal shot cups according to an exemplary embodiment.

FIG. 11 is a packaging for metal shot cups according to another exemplary embodiment.

FIG. 12 is a packaging for metal shot cups according to another exemplary embodiment.

## DETAILED DESCRIPTION

**[0009]** Referring generally to the figures, various embodiments of a metal container, such as a metal shot cup, are shown. As discussed herein, Applicant has developed a one-piece multi-tapered metal shot cup with a number of improvements relative to single-use plastic cups. In one embodiment, the metal shot cup includes a wall thickness that is relatively small allowing for an overall smaller weight of the cup while the metal material creates a robust shot cup suitable for multiple uses. The metal shot cup includes one or more tapered sections allowing for dense packaging. The metal material, the reusable nature of the metal shot cup, and the tapered shape contribute to decreased negative health and environmental impact (i.e., less chemical ingestion by users, pollution, dense packing, etc.) compared to conventional plastic shot cups. Furthermore, the multi-tapered shape of the shot cup allows for improved grasping for users.

**[0010]** Referring to FIG. 1, a metal container, shown as a thin-walled, metal shot cup 10, is shown according to an exemplary embodiment. Metal shot cup 10 includes a body 12 coupled to a rolled top edge shown as rim 18. Body 12 extends along and is centered on a longitudinal axis, shown as a central axis 20 between a top end or first end 14 and a bottom or second end 16. The top end or first

end 14 is positioned adjacent to rim 18 and the bottom or second end 16 opposes the top end 14. Top end 14 of body 12 includes an opening or bore 22 centered around longitudinal, central axis 20.

**[0011]** Body 12 is at least partially defined by a sidewall 24. Body 12 further includes an exterior surface 28 and an interior surface 26. An inner edge 19 of rim 18 at least partially defines bore 22. Bore 22 extends along and is centered on longitudinal, central axis 20 between top end 14 and bottom end 16. In various embodiments, metal shot cup 10 may include a container lid or cover 30. The container cover may be any element that allows the metal shot cup 10 to be sealed such that the container is capable of enclosing a liquid (i.e., prevent spilling). In various specific embodiments, cover 30 is a snap top. In other specific embodiments, cover 30 is a formed from cellulose such as a cellophane cover. In other specific embodiments, cover 30 is a foil cover.

**[0012]** In various specific embodiments, metal shot cup 10 is formed as a single, unitary, integral, or one-piece cup. In various embodiments, metal shot cup 10 is formed from aluminum. In such an embodiment, metal shot cup 10 is formed from aluminum alloy 3104.

**[0013]** In various specific embodiments, metal shot cup 10 includes a polymer coating on at least a portion of sidewall 24. In various specific embodiments, metal shot cup 10 includes a polymer coating on at least one of the exterior surface 28 and interior surface 26. Applicant believes the use of a polymer coating provides protection to the surface of the metal shot cup and/or reduces metallic taste. In a specific embodiment, the polymer coating is a PPE (polyphenylene ether) coating. The polymer coating is not a PET coating (polyethylene terephthalate) that can oxidize and result in degradation of the coating and/or the taste of the liquid that interacts with the coating. Applicant believes the PPE coating provides durable protection with reduced likelihood of degradation and/or oxidization that may alter the taste of the liquid within the metal shot cup 10.

**[0014]** In various embodiments, the polymer coating is on both interior surface 26 and exterior surface 28 of metal shot cup 10. In such an embodiment, the coating on interior surface 26 has a first color and the coating on exterior surface 28 has a second color. The first color is different from the second color. In various specific embodiments, the first color is white and the second color is green. In other embodiments, the first color is white and the second color is one of various colors (e.g., green, red, yellow, blue, etc.). In other embodiments, the coating is on one of interior surface 26 and exterior surface 28. In various embodiments, the coating has a thickness defined between the exterior of the coating and the interior surface 26 or exterior surface 28 of metal shot cup 10. The coating thickness is between 35 and 15 microns, more specifically between 30 and 20 microns and in such an embodiment, the coating is about 25 microns  $\pm$  5 microns. In various specific embodiments the coating thickness is less than 35 microns and specifically less

than 30 microns.

**[0015]** Referring to FIGS. 2-5, side views of metal shot cup 10 are shown, according to an exemplary embodiment. As noted above, body 12 and/or sidewall 24 include more than one taper or tapered section. In various embodiments, sidewall 24 includes a first tapered section 32, a second tapered section 34 and an upper section 36. First tapered section 32 extends generally upward from a bottom wall 40. Bottom wall 40 includes a bottom wall edge 38 at second end 16 of metal shot cup 10 and a trough 42 (see e.g., FIGS. 6 and 8) at the periphery of bottom wall 40.

**[0016]** First tapered section 32 is positioned between bottom wall 40 and second tapered section 34. Second tapered section 34 is positioned between first tapered section 32 and upper section 36. Upper section 36 is positioned between second tapered section 34 and rim 18. Sidewall 24 includes an upper boundary or edge 44 of first tapered section 32. Upper boundary 44 is positioned between first tapered section 32 and second tapered section 34. Sidewall 24 further includes a lower boundary or edge 46 of upper section 36. Lower boundary 46 is positioned between upper section 36 and second tapered section 34. In various embodiments, upper section 36 is a third tapered section. In such an embodiment, metal shot cup 10 is entirely stackable due to the taper. In other embodiments, upper section 36 is generally vertical (i.e., perpendicular to bottom wall 40 and/or rim 18 plus or minus 10 degrees) extending along longitudinal axis 20.

**[0017]** In various specific embodiments, the lower boundary 46 of upper section 36 which is the upper boundary of second tapered section 34 is positioned to indicate a volume of 1 oz. In general, metal shot cup 10 and specifically bore 22 can contain 1.5 oz. of liquid.

**[0018]** In various specific embodiments, the tapered sections 32, 34, 36 of sidewall 24 may have varying angles relative to a reference parallel to longitudinal axis 20. A first angle, shown as A1 is defined as the angle between the wall of first tapered portion 32 and longitudinal axis 20. In a specific embodiment A1 is between 1 and 10 degrees, more specifically between 1 and 5 degrees and in such an embodiment A1 is about 2 degrees (i.e., 2 degrees  $\pm$  0.5 degrees).

**[0019]** In various embodiments, second tapered section 34 includes a second angle A2, defined as the angle between the wall of second tapered section 34 and longitudinal axis 20. In various embodiments, A2 is greater than A1. In a specific embodiment A2 is between 30 and 38 degrees, more specifically between 32 and 36 degrees and in such an embodiment A2 is about 34 degrees (i.e., 34 degrees  $\pm$  2 degrees). In various embodiments, upper section 36 includes a third angle A3, defined as the angle between the wall of upper section 36 and longitudinal axis 20. In various specific embodiments, A3 is less than A1 and A2. In a specific embodiment, A3 of upper section 36 is about 0 degrees (i.e., 0 degrees  $\pm$  0.5 degrees). In various specific embodiment A3 is between 0 and 2 degrees, more specifically between 0 and 1

degrees and in such an embodiment A3 is about 0 degrees (i.e., 0 degrees  $\pm$  1 degrees).

**[0020]** Referring to FIG. 5, a first height, shown as H1 is defined between rim 18 and lower boundary 46 of upper section 36. In a specific embodiment, H1 is between .4 and .5 inches and in such an embodiment H1 is about .44  $\pm$  0.02 inches.

**[0021]** Referring to FIGS. 6-7, a top view and bottom view of metal shot cup 10 are shown. The difference in the diameters of the tapered sections 32, 34 and upper section 36 and bottom wall 40 are shown. Trough 42 defines a lowermost point of bottom wall 40. Bottom wall 40 further includes an exterior bottom surface 37 connected to bottom wall edge 38 by trough 42. As shown in FIG. 8, trough 42 includes a depth, shown as B1. In various specific embodiments, B1, is between .03 and .05 inches, more specifically between .035 and .045 inches, and in such an embodiment is about .04 inches  $\pm$  0.02 inches.

**[0022]** Referring to FIG. 8, a cross-sectional view of metal shot cup 10 and cover 30 is shown, according to an exemplary embodiment. A total height of metal shot cup 10, shown as H2 is defined between a top of rim 18 and a bottom of trough 42. In various specific embodiments, the height of the metal shot cup 10 is less than 2.5 inches and more specifically less than 2 inches. In a specific embodiment, H2 is between 1.5 and 2.1 inches, more specifically between 1.6 and 2 inches and in such an embodiment is about 1.8 inches  $\pm$  0.1 inches.

**[0023]** At top end 14 of body 12, a first diameter shown as D1 is defined between opposing outside edges of rim 18. In a specific embodiment, D1 is between 1.5 and 2.1 inches, more specifically between 1.6 and 2 inches and in such an embodiment is about 1.8 inches  $\pm$  0.02 inches. Bore 22 and interior surface 26 define a second diameter, shown as D2. Specifically, D2 is defined at top end 14 defining the diameter of upper section 36. In a specific embodiment, D2 is between 75% and 95% of D1, specifically between 80% and 90% of D2 and more specifically between 84% and 87% of D1. In a specific embodiment, D2 is between 1.4 and 1.7 inches and in such embodiments D2 is about 1.56 inches  $\pm$  0.02 inches.

**[0024]** At bottom end 16 of body 12, defines a third diameter shown as D3. D3 is defined as an outside diameter between opposing portions of trough 42. In a specific embodiment, D3 is between 1.2 and 1.6 inches and in such embodiments D3 is about 1.4 inches  $\pm$  0.02 inches. In a specific embodiment D3 is between 65% and 85% of D1, specifically between 70% and 80% of D1 and more specifically between 76% and 79% of D1.

**[0025]** Rim 18 is tightly curved and includes a thickness, shown as T1. In a specific embodiment, T1 is between .07 and .1 inches, more specifically between .085 and .095 and in such an embodiment is about .09 inches  $\pm$  0.01 inches. In various specific embodiments, T1 is less than .1 inches. Rim 18 includes an outer curved surface 25. Outer curved surface 25 defines

a first radius shown as R1. In various specific embodiments, R1 is less than .1 inches, specifically less than .075 inches, and more specifically less than .05 inches. In a specific embodiment, R1 is between .03 and .06 inches, more specifically between .04 and .05 inches and in such embodiments is about  $.045 \pm 0.01$  inches. In other words, rim 18 has a small radius with a high curvature.

**[0026]** A wall thickness of sidewall 24 shown as T2 is defined between exterior surface 28 and interior surface 26 at upper section 36. In various specific embodiments, T2 is between 0.0062 and 0.0078 inches, more specifically between 0.0062 and 0.0070 inches and in such embodiments is about  $0.0065 \pm 0.0005$  inches. A wall thickness of sidewall 24 shown as T3 is defined between exterior surface 28 and interior surface 26 at first tapered portion 32. In various specific embodiments, T3 is between 0.0062 and 0.0078 inches, more specifically between 0.0062 and 0.0070 inches and in such embodiments is about  $0.0065 \pm 0.0005$  inches.

**[0027]** An internal curved surface 35 connects upper section 36 to second tapered section 34 along interior surface 26. Internal curved surface 35 has a radius shown as R2. In a specific embodiment, R2 is between .02 and .06 inches, more specifically between .03 and .05 inches and in such an embodiment R2 is about  $.04 \pm 0.01$  inches.

**[0028]** Referring to FIGS. 9-12, a plurality of metal shot cups 10 are shown in a stacked arrangement, according to an exemplary embodiment. The multi-tapered shape of the metal shot cup 10 allows for ease of stacking (i.e., positioning one metal shot cup 10 within the bore 22 of another metal shot cup 10) and packing a plurality of cups into a kit (see e.g., FIGS. 10-12). As shown in FIG. 9, the plurality of metal shot cups 10 together form a stack 100. In various embodiments, when A3 of upper section 36 is about 0 degrees, the upper section 36 of the metal shot cup 10 will extend upward (in the orientation shown in FIG. 9) and outward from the lower metal shot cup 10 when the plurality of metal shot cups 10 are in stack 100. In various embodiments, when A3 of upper section 36 is greater than zero (i.e., tapered), the upper section 36 is positioned and/or received within the lower metal shot cup 10 in stack 100 such that upper section 36 is positioned within the bore 22 of an adjacent shot cup in stack 100. In other words, when upper section 36 includes a taper, metal shot cups 10 allow for complete stacking.

**[0029]** Referring to FIG. 10, a kit 110 is shown according to an exemplary embodiment. Kit 110 includes a plurality of metal shot cups 10 and a container, shown as generally cylindrical tube 112 configured to store the plurality of metal shot cups 10. Kit 110 includes a stack 100 of metal shot cups 10 positioned within a bore 114 of a generally cylindrical tube 112. In other words, cylindrical tube 112 generally has the shape of a cylindrical prism. In various embodiments, stack 100 includes a plurality of metal shot cups 10. In various specific embodiments, stack 100 includes ten metal shot cups 10. In other

embodiments, stack 100 includes a different number of metal shot cups 10 (i.e., 6, 8, 12, 20, 24, etc.).

**[0030]** Referring to FIG. 11, a kit 120 is shown according to an exemplary embodiment. Kit 120 includes a stack 100 of metal shot cups 10 positioned within a bore 112 of a generally triangular tube 122. In other words, triangular tube 122 generally has the shape of a triangular prism. Referring to FIG. 12, a kit 130 is shown according to an exemplary embodiment. Kit 130 includes a stack 100 of metal shot cups 10 positioned within a bore 134 of a generally rectangular tube 132. In other words, rectangular tube 132 generally has the shape of a rectangular prism with bore 134 having a square shape.

**[0031]** It should be understood that the figures illustrate the exemplary embodiments in detail, and it should be understood that the present application is not limited to the details or methodology set forth in the description or illustrated in the figures. It should also be understood that the terminology is for the purpose of description only and should not be regarded as limiting.

**[0032]** Further modifications and alternative embodiments of various aspects of the disclosure will be apparent to those skilled in the art in view of this description. Accordingly, this description is to be construed as illustrative only. The construction and arrangements, shown in the various exemplary embodiments, are illustrative only. Although only a few embodiments have been described in detail in this disclosure, many modifications are possible (e.g., variations in sizes, dimensions, structures, shapes and proportions of the various elements, values of parameters, mounting arrangements, use of materials, colors, orientations, etc.) without materially departing from the novel teachings and advantages of the subject matter described herein. Some elements shown as integrally formed may be constructed of multiple parts or elements, the position of elements may be reversed or otherwise varied, and the nature or number of discrete elements or positions may be altered or varied. The order or sequence of any process, logical algorithm, or method steps may be varied or re-sequenced according to alternative embodiments. Other substitutions, modifications, changes and omissions may also be made in the design, operating conditions and arrangement of the various exemplary embodiments without departing from the scope of the present disclosure.

**[0033]** Unless otherwise expressly stated, it is in no way intended that any method set forth herein be construed as requiring that its steps be performed in a specific order. Accordingly, where a method claim does not actually recite an order to be followed by its steps or it is not otherwise specifically stated in the claims or descriptions that the steps are to be limited to a specific order, it is in no way intended that any particular order be inferred. In addition, as used herein, the article "a" is intended to include one or more component or element, and is not intended to be construed as meaning only one.

**[0034]** For purposes of this disclosure, the term "coupled" means the joining of two components directly

or indirectly to one another. Such joining may be stationary in nature or movable in nature. Such joining may be achieved with the two members and any additional intermediate members being integrally formed as a single unitary body with one another or with the two members or the two members and any additional member being attached to one another. Such joining may be permanent in nature or alternatively may be removable or releasable in nature. As used herein, "rigidly coupled" refers to two components being coupled in a manner such that the components move together in a fixed positional relationship when acted upon by a force.

**[0035]** While the current application recites particular combinations of features in the claims appended hereto, various embodiments of the invention relate to any combination of any of the features described herein whether or not such combination is currently claimed, and any such combination of features may be claimed in this or future applications. Any of the features, elements, or components of any of the exemplary embodiments discussed above may be used alone or in combination with any of the features, elements, or components of any of the other embodiments discussed above.

**[0036]** In various exemplary embodiments, the relative dimensions, including angles, lengths and radii, as shown in the Figures are to scale. Actual measurements of the Figures will disclose relative dimensions, angles and proportions of the various exemplary embodiments. Various exemplary embodiments extend to various ranges around the absolute and relative dimensions, angles and proportions that may be determined from the Figures. Various exemplary embodiments include any combination of one or more relative dimensions or angles that may be determined from the Figures. Further, actual dimensions not expressly set out in this description can be determined by using the ratios of dimensions measured in the Figures in combination with the express dimensions set out in this description.

## Claims

### 1. A metal shot cup comprising:

a first end of the shot cup;  
 a second end of the shot cup opposing the first end of the shot cup;  
 a circular rim extending between an outside edge and an inside edge centered on a longitudinal axis, the circular rim having a radius less than .05 inches;  
 a sidewall extending between the first end and second end of the shot cup and centered on the longitudinal axis, the sidewall comprising:

an exterior surface;  
 an interior surface; and  
 a plurality of tapered sections, the tapered

sections extending between the first end and the second end of the shot cup;

a bottom including a circular surface generally parallel to the circular rim and centered on the longitudinal axis, the circular surface connecting to a trough at an outside edge of the circular surface; and  
 a polymer coating on at least a portion of the sidewall.

2. The metal shot cup of claim 1, wherein the metal shot cup is formed from a single, integral piece of metal.

3. The metal shot cup of claim 2, wherein the metal shot cup is formed from aluminum.

4. The metal shot cup of claim 1, wherein the polymer coating is on the interior surface and the exterior surface of the sidewall, preferably wherein the polymer coating on the interior surface has a first color and wherein the polymer coating on the exterior surface has a second color, further preferably wherein the first color is different from the second color.

5. The metal shot cup of claim 4, wherein the polymer coating is formed from polyphenylene ether.

6. The metal shot cup of claim 1, wherein the plurality of tapered sections comprises:

a first tapered section, the first tapered section extending generally upward from the bottom and having a first angle; and  
 a second tapered section having a second angle;  
 wherein the first tapered section is positioned between the bottom and the second tapered section.

7. The metal shot cup of claim 6, further comprising an upper section, the upper section positioned between the second tapered section and the circular rim.

8. The metal shot cup of claim 1, further comprising a cover couplable to the circular rim, the cover forming a tight seal that seals contents stored within the metal shot cup.

9. A one-piece metal shot cup comprising:

an open end of the shot cup including a bore;  
 a closed end of the shot cup opposing the open end of the shot cup;  
 a rim extending between an outside edge and an inside edge centered on a longitudinal, central axis;  
 a sidewall extending between the open end and

closed end of the shot cup and centered on the longitudinal, central axis, the sidewall comprising:

- an exterior surface; 5
- an interior surface;
- a first tapered section, the first tapered section extending at a first angle relative to the longitudinal, central axis;
- a second tapered section extending at a 10 second angle relative to the longitudinal, central axis;
- an upper section;

a bottom including a circular surface generally 15 parallel to the rim and centered on the longitudinal, central axis, the circular surface connecting to a trough at an outside edge of the circular surface;

wherein the first tapered section is positioned 20 between the bottom and the second tapered section; and

wherein the upper section is positioned between the second tapered section and the rim. 25

**10.** The one-piece metal shot cup of claim 9, further comprising an upper boundary of the second tapered section, the upper boundary of the second tapered section positioned between the second tapered section and the upper section, wherein the upper boundary indicates a volume of 1 oz. 30

**11.** The one-piece metal shot cup of claim 9, wherein the second angle is greater than the first angle. 35

**12.** The one-piece metal shot cup of claim 10, wherein a thickness of the rim is defined between the outside edge of the rim and the inside edge of the rim, wherein the thickness of the rim is less than 0.1 inches. 40

**13.** The one-piece metal shot cup of claim 10, further comprising a polyphenylene ether coating on the interior surface and the exterior surface of the sidewall, preferably wherein the polyphenylene ether coating on the interior surface has a first color and wherein the polyphenylene ether coating on the exterior surface has a second color. 45

**14.** A one-piece metal shot cup kit comprising: 50

a plurality of one-piece metal shot cups, each one-piece metal shot cup comprising:

- an open end of the shot cup including a 55 central bore;
- a closed end of the shot cup opposing the open end of the shot cup;

a circular rim extending between an outside edge and an inside edge centered on a longitudinal axis, the circular rim having a radius less than .05 inches;

a sidewall extending between the open end and closed end of the shot cup and centered on the longitudinal axis, the sidewall comprising:

- an exterior surface;
- an interior surface; and
- a plurality of tapered sections extending between the open end and the closed end of the shot cup, the plurality of tapered sections each extending at an angle relative to the longitudinal axis;

a bottom including a circular surface generally parallel to the circular rim and centered on the longitudinal axis, the circular surface connecting to a trough at an outside edge of the circular surface; and

a container configured to hold the plurality of one-piece metal shot cups when the plurality of one-piece metal shot cups are stacked.

**15.** The one-piece metal shot cup kit of claim 14, wherein each of the plurality of one-piece metal shot cups includes a height defined between a top of the circular rim and a lower edge of the trough and wherein the height is less than 2 inches, and/or wherein the container further comprises a cylindrical tube with a bore, wherein the plurality of one-piece metal shot cups are stacked within the bore of the cylindrical tube, and/or further comprising a plurality of covers, each cover couplable to the circular rim of the plurality of shot cups. 55

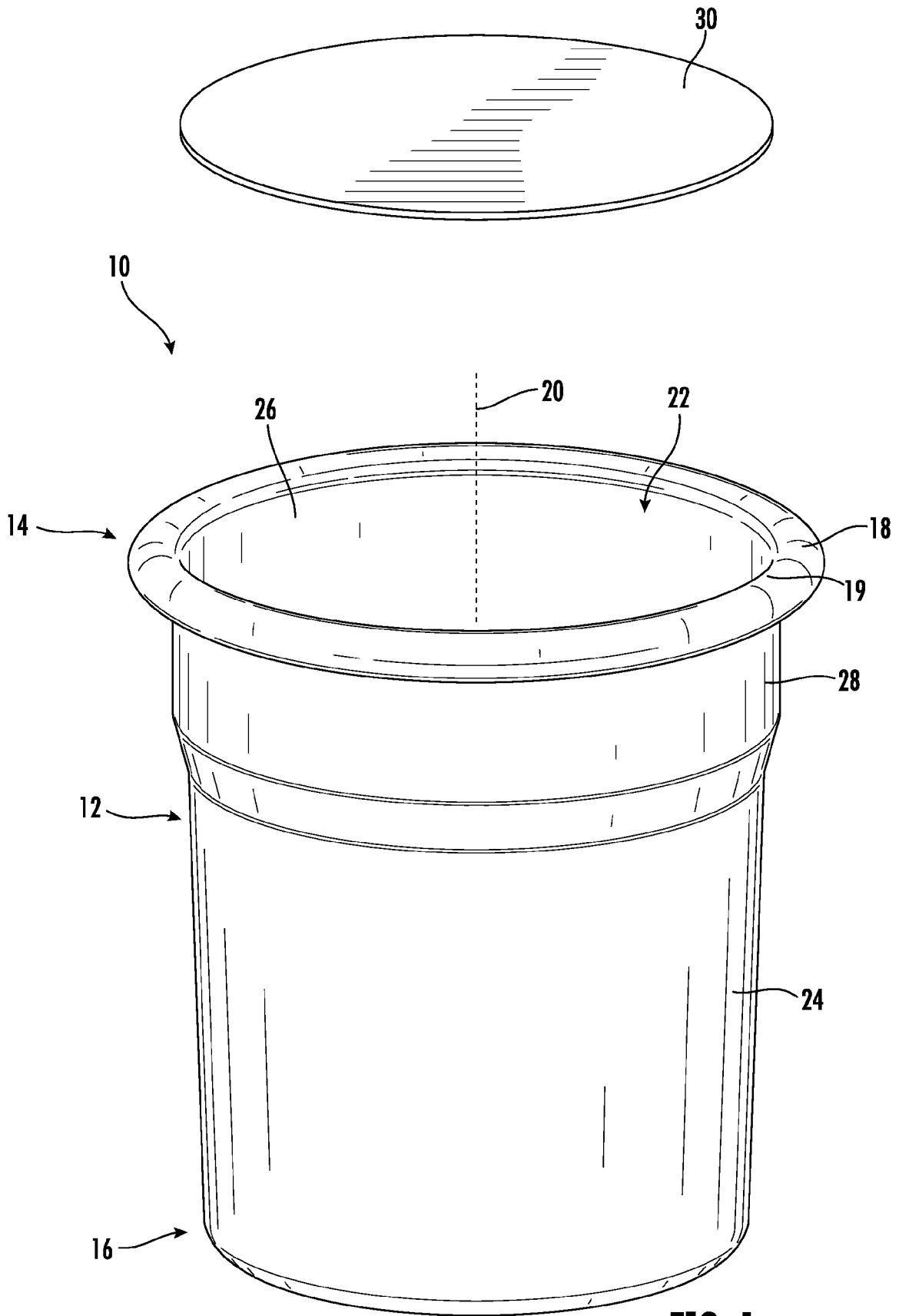

FIG. 1

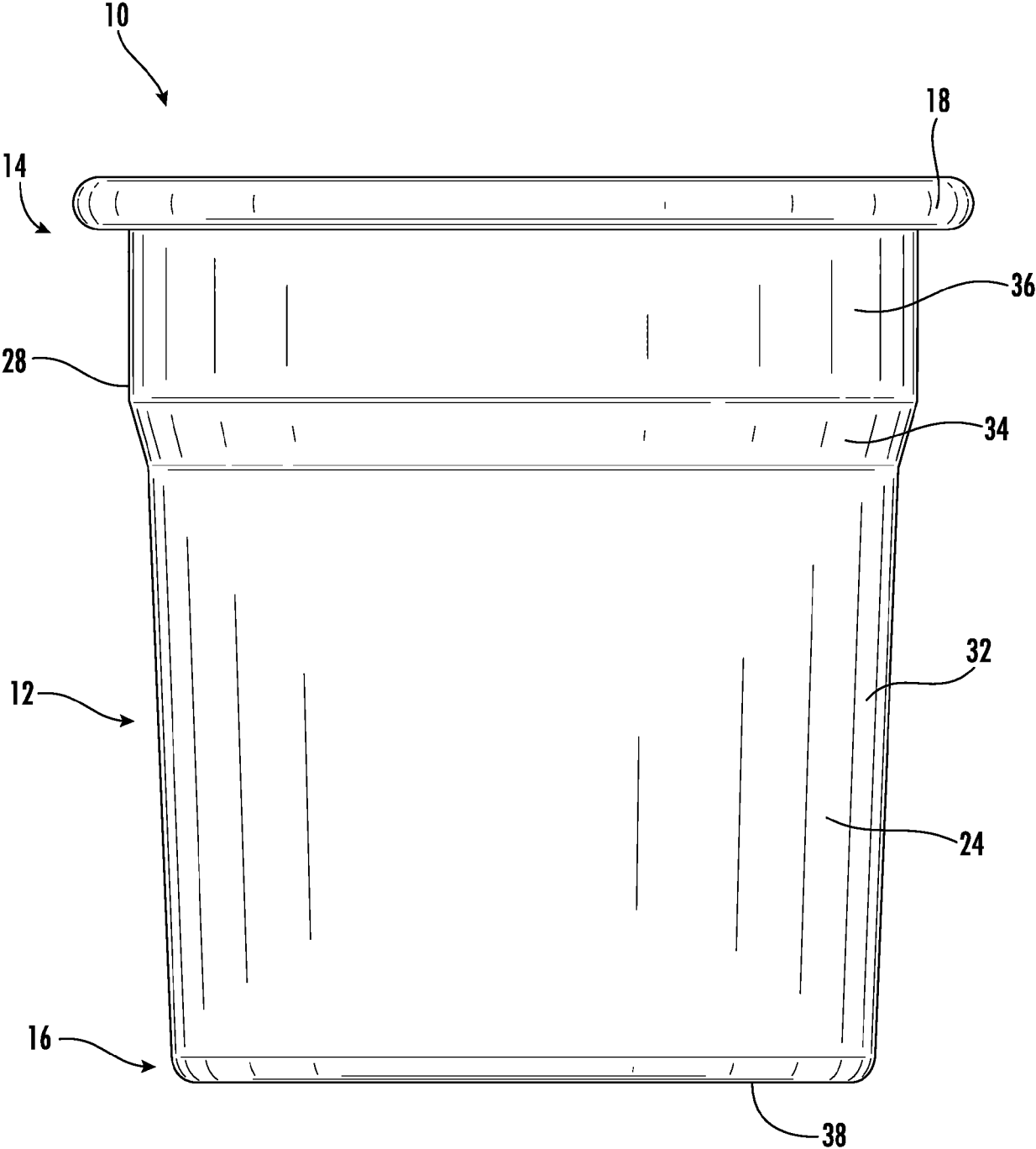

FIG. 2

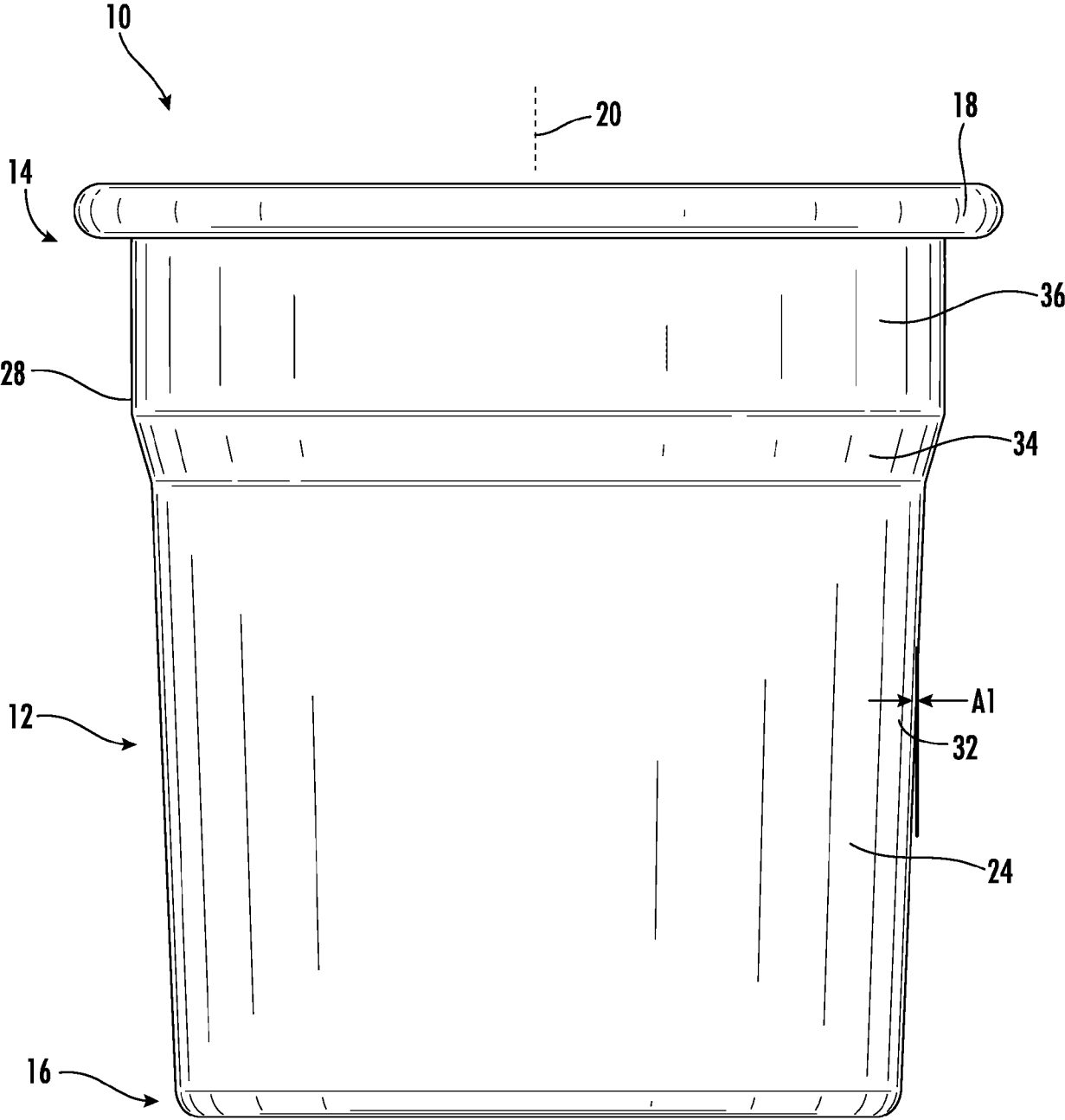

FIG. 3

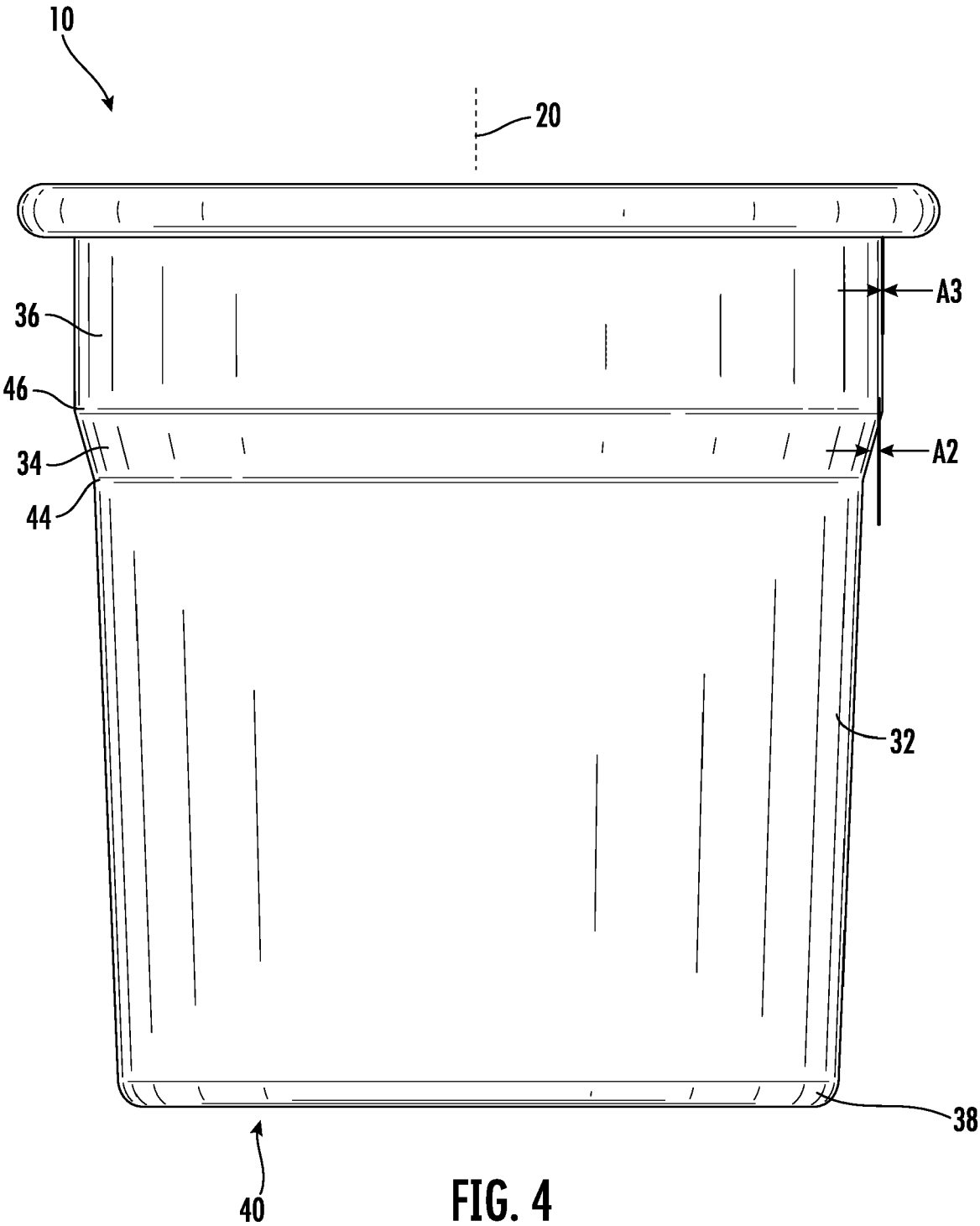

FIG. 4

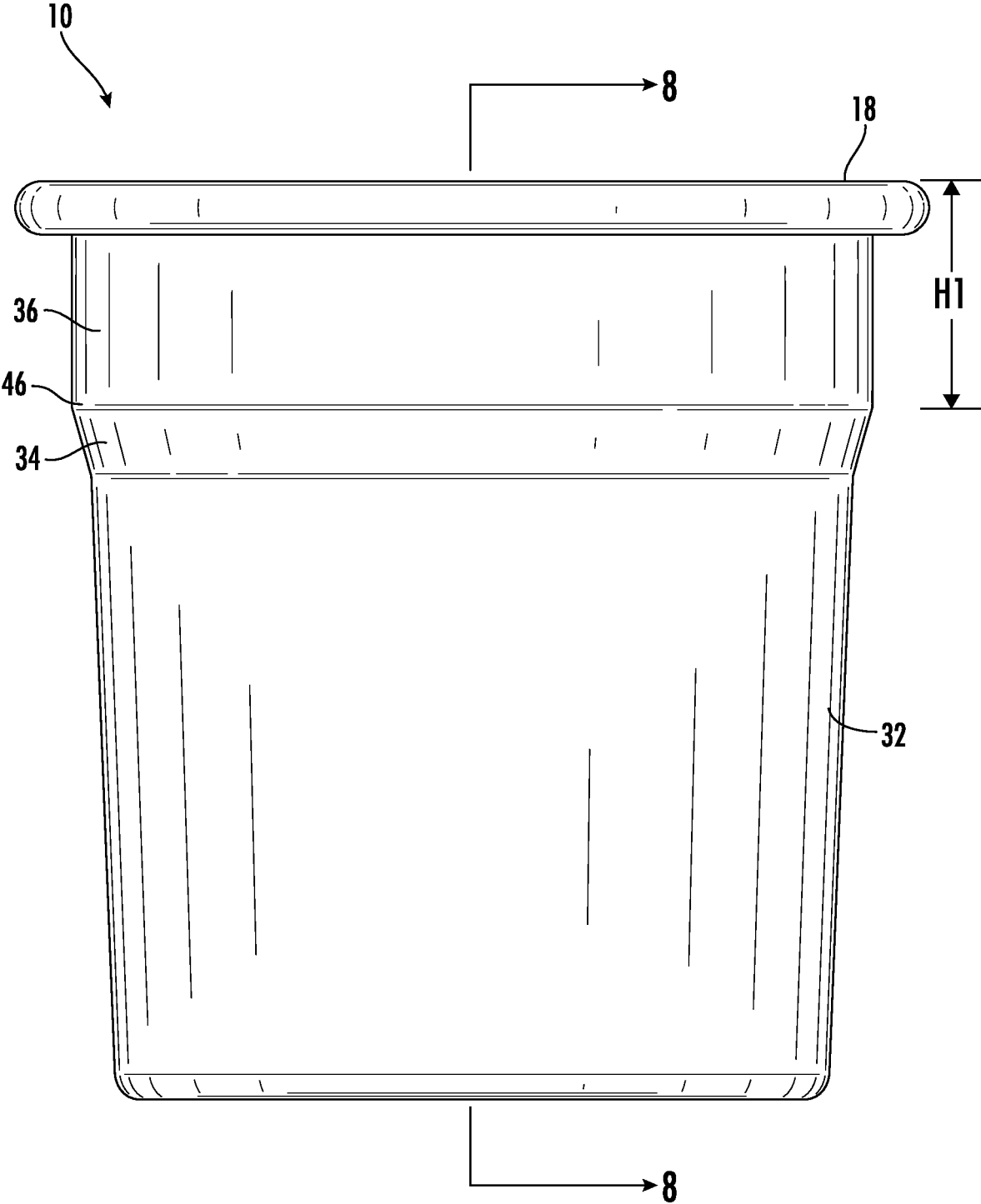
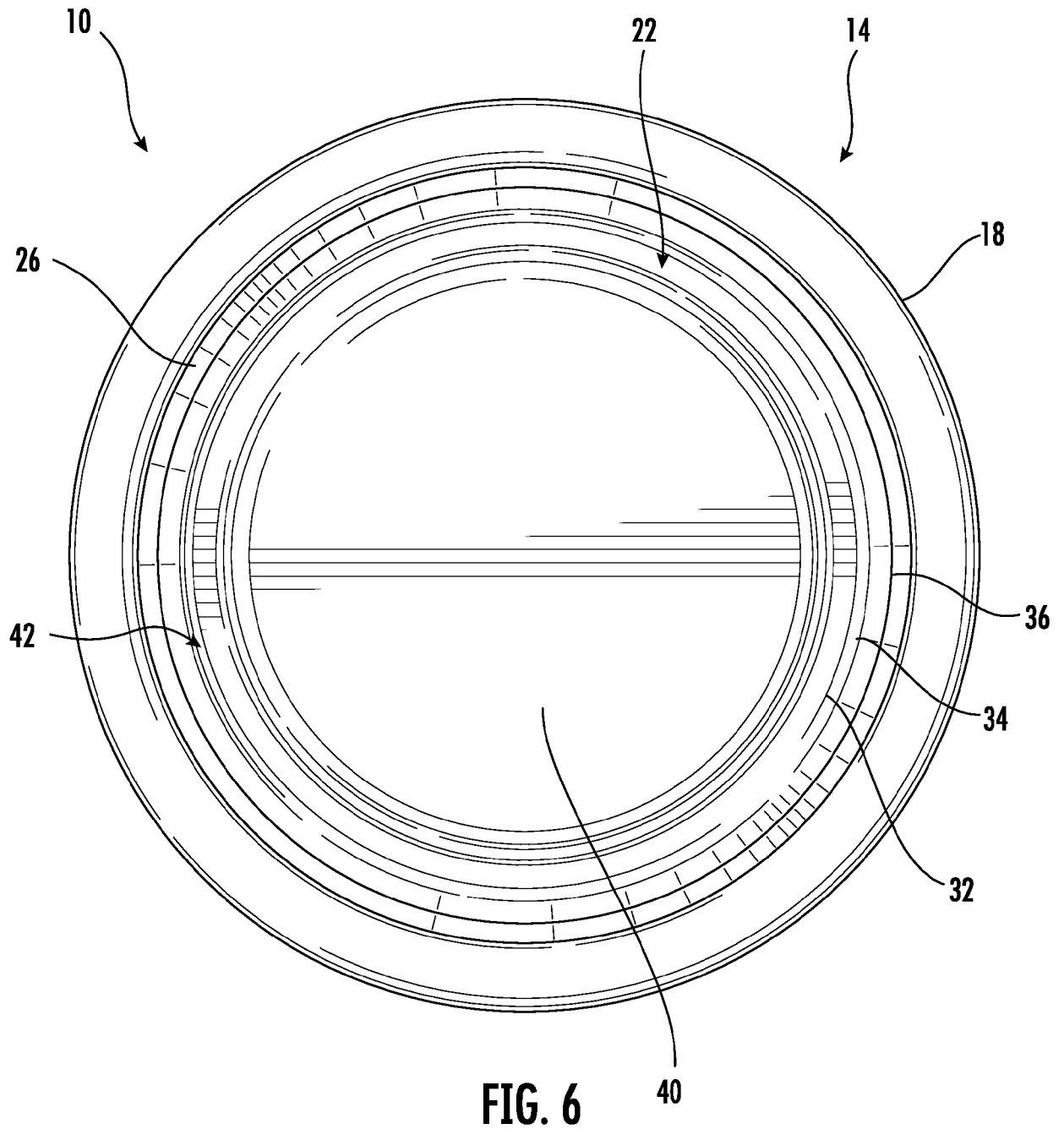

FIG. 5



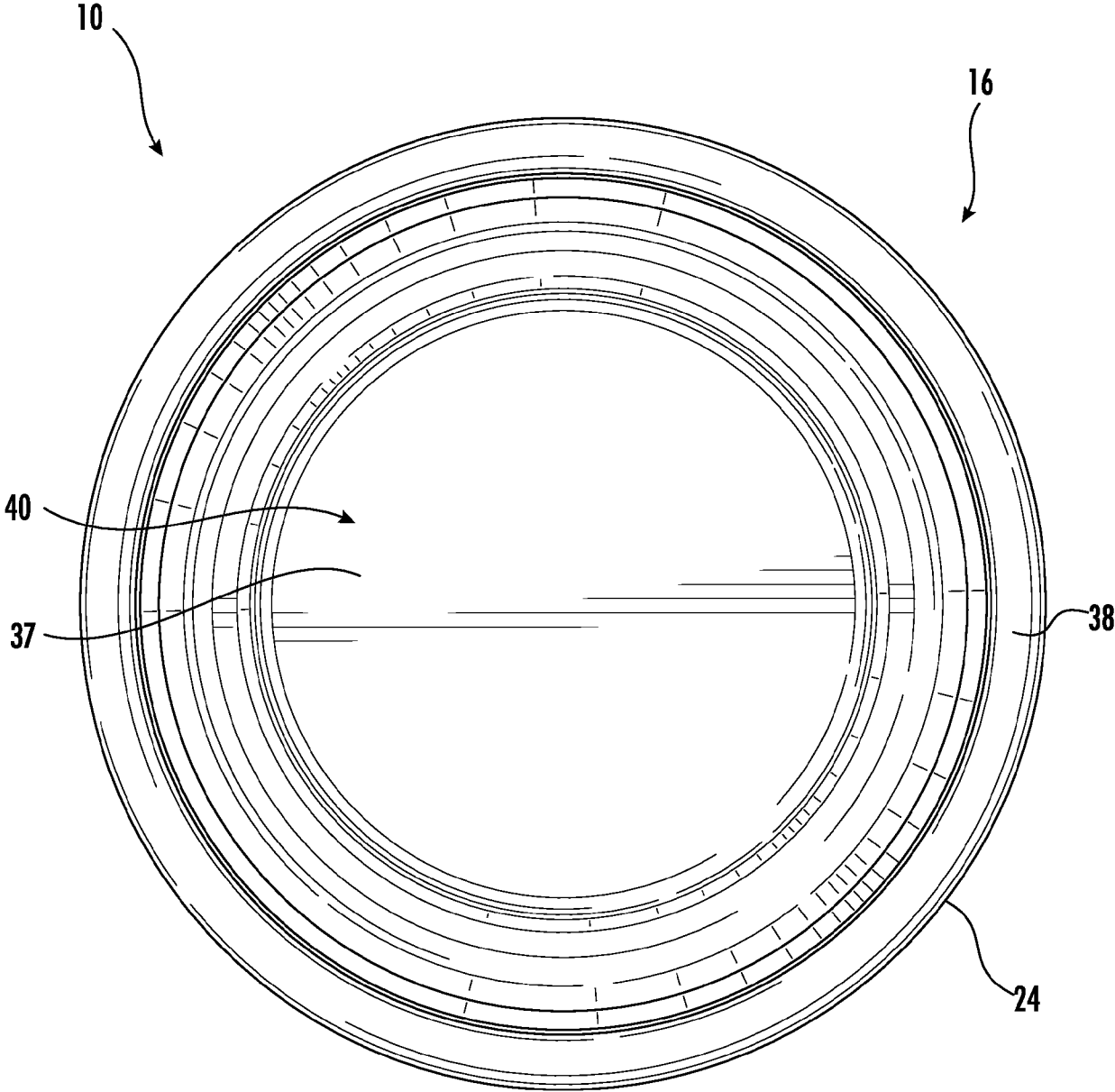

FIG. 7

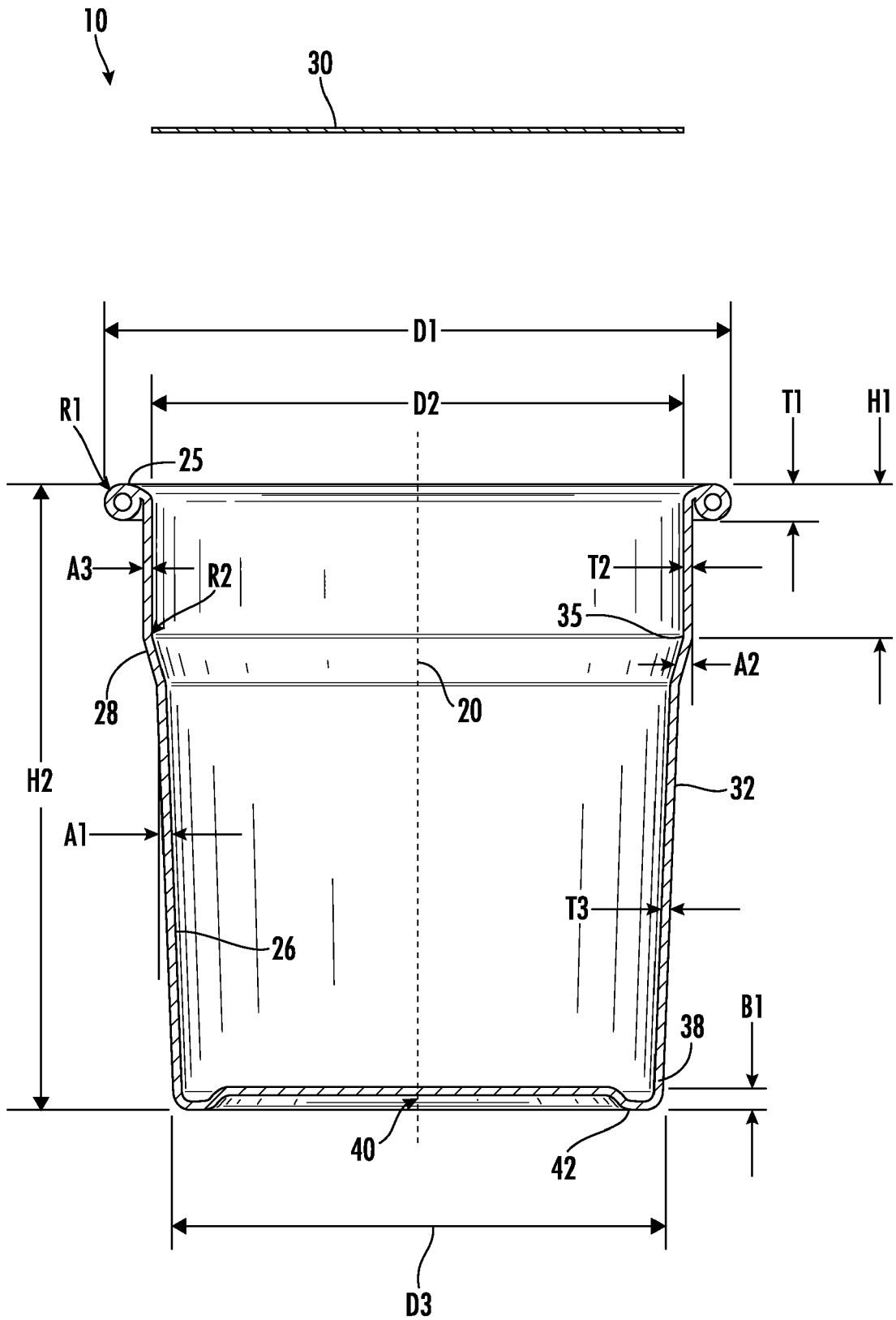

FIG. 8

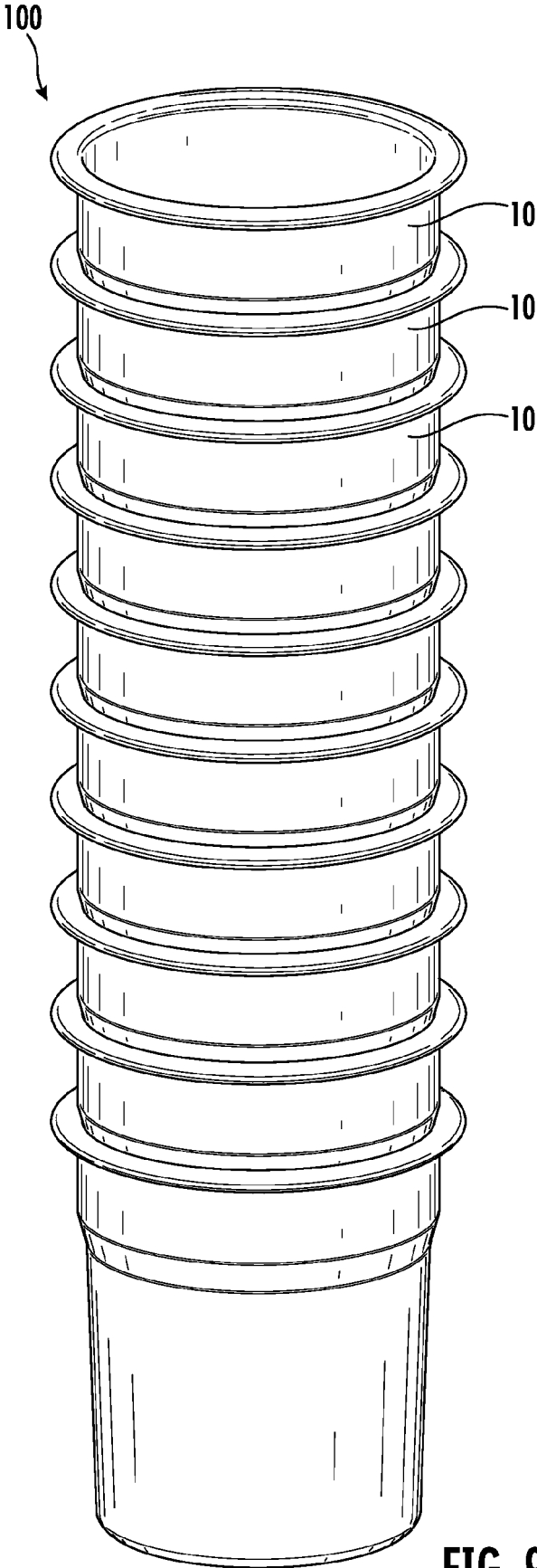
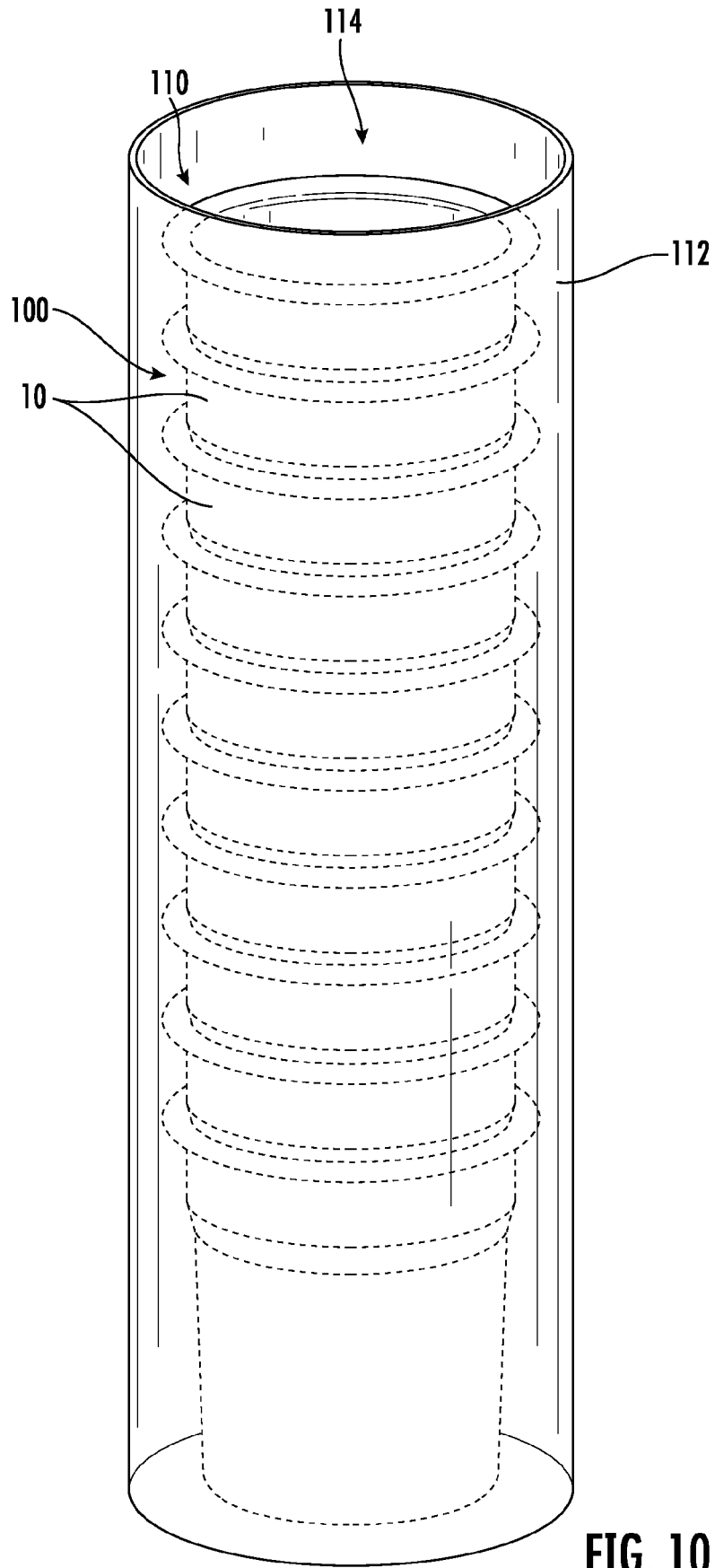

FIG. 9



**FIG. 10**

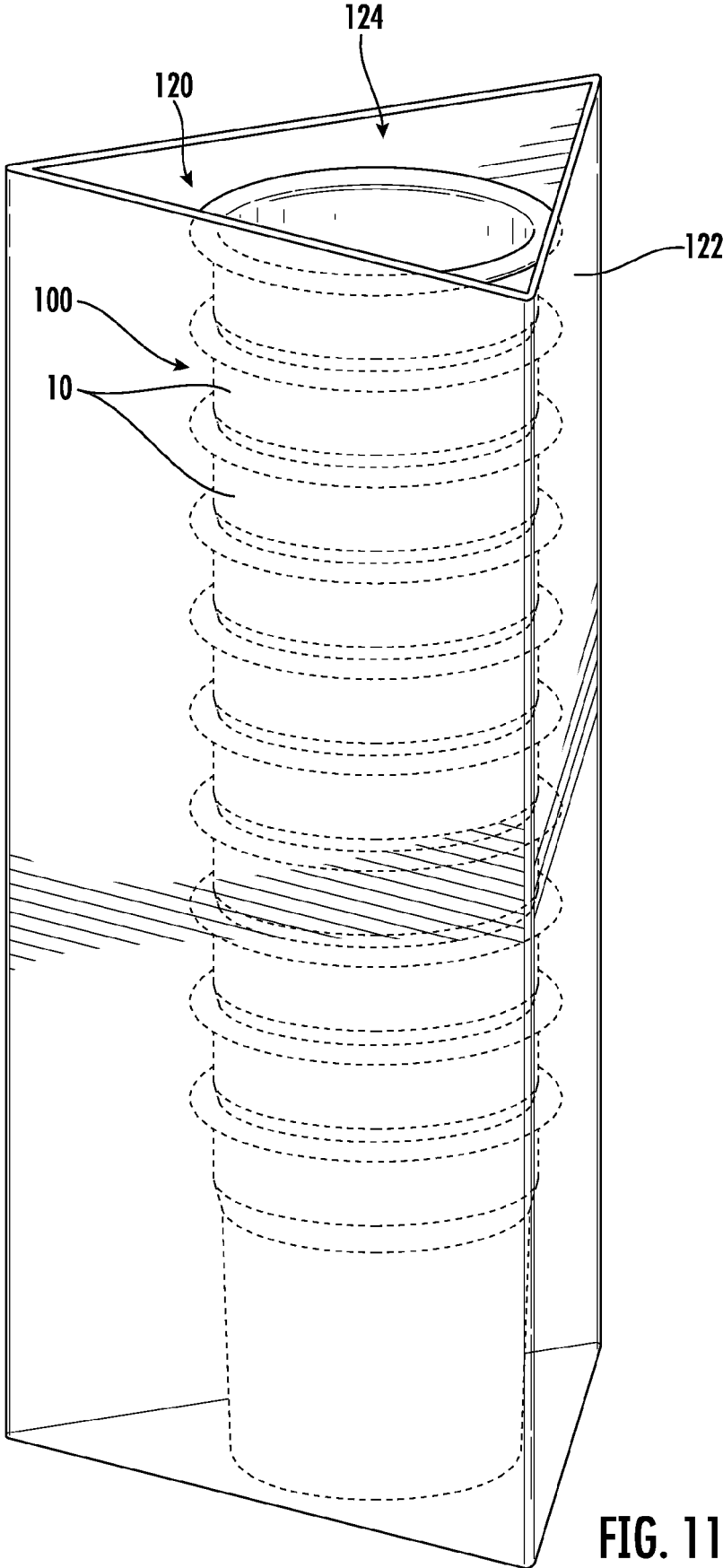

FIG. 11

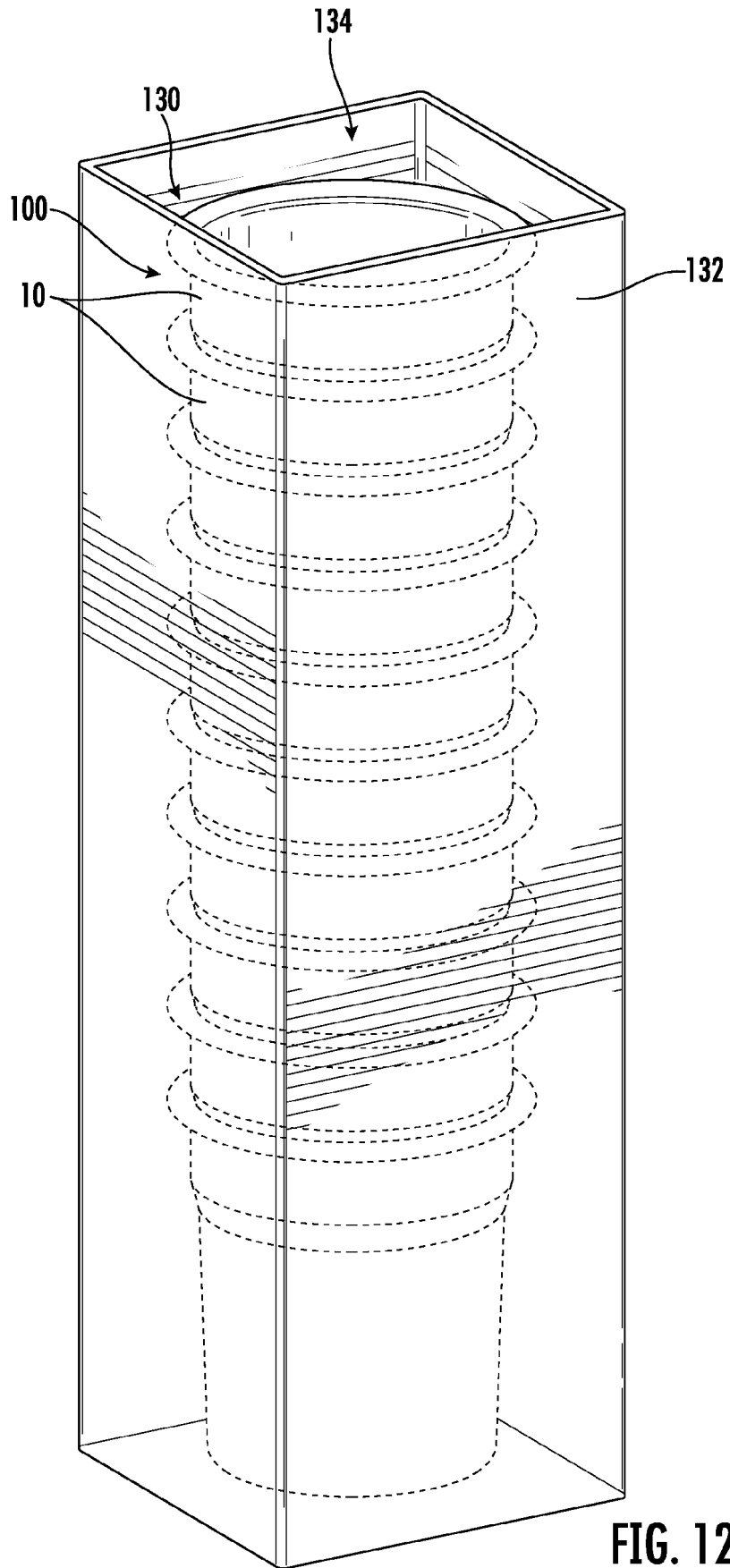

FIG. 12



EUROPEAN SEARCH REPORT

Application Number

EP 24 18 9099

5

10

15

20

25

30

35

40

45

50

55

EPO FORM 1503 03.82 (P04C01)

DOCUMENTS CONSIDERED TO BE RELEVANT			
Category	Citation of document with indication, where appropriate, of relevant passages	Relevant to claim	CLASSIFICATION OF THE APPLICATION (IPC)
X	US 6 288 012 B1 (LI MINYU [US] ET AL) 11 September 2001 (2001-09-11)	1-4, 6-12	INV. B65D1/26 B65D3/06 B65D71/14 B65D23/08 B65D77/20
Y	* paragraphs [0032], [0043]; figures 1-6 *	5, 13-15	
Y	WO 2023/018702 A1 (SILGAN CONTAINERS LLC [US]) 16 February 2023 (2023-02-16) * column 2, line 25 - column 3, line 32 *	5, 13	
X	US 2023/047517 A1 (HOLSTINE ROWDY [US] ET AL) 16 February 2023 (2023-02-16)  * figures 1-7 *	1-4, 6-12, 14, 15	
X	US 2021/300617 A1 (BELEN ANDREW [US]) 30 September 2021 (2021-09-30) * figures 1-16 *	1-4, 6, 12, 14, 15	
X	WO 2022/093188 A1 (SILGAN CONTAINERS LLC [US]) 5 May 2022 (2022-05-05)  * figures 1-8 *	1-4, 6-12, 14, 15	TECHNICAL FIELDS SEARCHED (IPC)
Y	US 2005/092641 A1 (MARSDEN ANDREW W [US] ET AL) 5 May 2005 (2005-05-05) * figures 1-5 *	14, 15	B65D
A	US 3 938 703 A (ROCCAFORTE HARRY I) 17 February 1976 (1976-02-17) * figures 1-12 *	1-15	
The present search report has been drawn up for all claims			
Place of search <b>Munich</b>		Date of completion of the search <b>6 December 2024</b>	Examiner <b>Jervelund, Niels</b>
CATEGORY OF CITED DOCUMENTS X : particularly relevant if taken alone Y : particularly relevant if combined with another document of the same category A : technological background O : non-written disclosure P : intermediate document		T : theory or principle underlying the invention E : earlier patent document, but published on, or after the filing date D : document cited in the application L : document cited for other reasons ..... & : member of the same patent family, corresponding document	

**ANNEX TO THE EUROPEAN SEARCH REPORT  
ON EUROPEAN PATENT APPLICATION NO.**

EP 24 18 9099

5 This annex lists the patent family members relating to the patent documents cited in the above-mentioned European search report.  
The members are as contained in the European Patent Office EDP file on  
The European Patent Office is in no way liable for these particulars which are merely given for the purpose of information.

06-12-2024

Patent document cited in search report	Publication date	Patent family member(s)	Publication date
US 6288012 B1	11-09-2001	NONE	
-----			
15 WO 2023018702 A1	16-02-2023	NONE	
-----			
US 2023047517 A1	16-02-2023	EP 4384051 A1	19-06-2024
		US 2023047517 A1	16-02-2023
-----			
20 US 2021300617 A1	30-09-2021	NONE	
-----			
WO 2022093188 A1	05-05-2022	EP 4237340 A1	06-09-2023
		US 2023257155 A1	17-08-2023
		WO 2022093188 A1	05-05-2022
-----			
25 US 2005092641 A1	05-05-2005	NONE	
-----			
US 3938703 A	17-02-1976	NONE	
-----			

EPO FORM P0459

For more details about this annex : see Official Journal of the European Patent Office, No. 12/82