

(19)



(11)

EP 4 506 524 A1

(12)

EUROPEAN PATENT APPLICATION

(43) Date of publication:
12.02.2025 Bulletin 2025/07

(51) International Patent Classification (IPC):
E05B 15/02^(2006.01)

(21) Application number: **23190932.6**

(52) Cooperative Patent Classification (CPC):
E05B 15/02; E05B 15/1607; E05B 2015/1657

(22) Date of filing: **10.08.2023**

(84) Designated Contracting States:
**AL AT BE BG CH CY CZ DE DK EE ES FI FR GB
 GR HR HU IE IS IT LI LT LU LV MC ME MK MT NL
 NO PL PT RO RS SE SI SK SM TR**
 Designated Extension States:
BA
 Designated Validation States:
KH MA MD TN

(71) Applicant: **Tupai, SA**
3754-901 Águeda (PT)

(72) Inventor: **GOMES PEREIRA, Francisco José Ovar (PT)**

(74) Representative: **do Nascimento Gomes, Rui J. Pereira da Cruz, S.A.**
Rua Vítor Cordon, 10-A
1249-103 Lisboa (PT)

(30) Priority: **08.08.2023 PT 2023118860**

(54) **A SCREWLESS COVER PLATE ASSEMBLY**

(57) It is described a screwless cover plate assembly that represents an improved cover plate assembly, such that the assembly work is reduced and simplified overall compared to the know solutions. The cover plate assembly described in the present application is comprised by two rosette sets, each set comprising a rosette element

(1) with fitting means (2) and an anchoring element (3) having screwless fixation means (5) to provide fixation to an installation surface on a door or window, and receiving elements (4) adapted to receive the fitting means (2) of the rosette element (1).

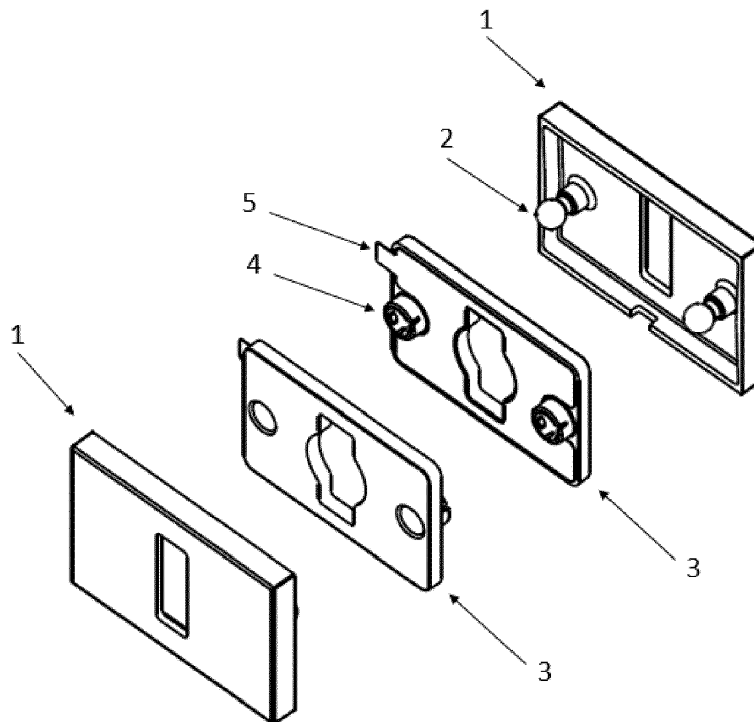

Figure 1

EP 4 506 524 A1

Description

3 - anchoring element;
 4 - receiving means of the anchoring element;
 5 - fixing means of the anchoring element.

FIELD OF THE INVENTION

[0001] The present invention is enclosed in the field of cover plates for key cylinder or knob handle openings.

5 Figure 2 - representation of an embodiment of the rosette element, part of the cover plate assembly object of the present application. The reference signs represent:

PRIOR ART

[0002] Cover plate assemblies are known to be applied to doors or windows, with the purpose of giving a more sophisticated finish, hiding the opening made on the respective surfaces to fit the cylinder key or knob handle.

10 1- rosette element;
 2 - fitting means of the rosette element;
 7 - opening to be aligned with the door or window frame opening, where a key cylinder or knob handle are to be inserted.

[0003] In order to provide the desired sophisticated finish, the installation of these devices is a complex procedure, not only because of the multiple elements that form such assembly, but also because each of said elements shall be installed in order to ensure that screws or other more complex fastening means used for this purpose are not visible.

15 Figure 3 - representation of an embodiment of the anchoring element, part of the cover plate assembly object of the present application. The reference signs represent:

[0004] For this reason, the installation of cover plates assemblies is carried out by a skilled handyman.

20 3 - anchoring element;
 4 - receiving means of the anchoring element;
 5 - fixing means of the anchoring element;
 7 - opening to be aligned with the door or window frame opening, where a key cylinder or knob handle are to be inserted.

[0005] The present solution intended to innovatively overcome such issues.

25 Figure 4 - representation of an embodiment of the anchoring element, part of the cover plate assembly object of the present application. The reference signs represent:

SUMMARY OF THE INVENTION

[0006] It is therefore an object of the present invention an improved cover plate assembly, such that the assembly work is reduced and simplified overall compared to the know solutions.

30 3 - anchoring element;
 4 - receiving means of the anchoring element;
 6 - retention filaments.

[0007] In an advantageous configuration of the cover plate assembly, it comprises two rosette sets, each set comprising a rosette element with fitting means and an anchoring element having screwless fixation means to provide fixation to an installation surface, and receiving elements of an elastic material that are provided with retention filaments.

DETAILED DESCRIPTION

[0008] It therefore provides a simplified way to install a rosette set, since the anchoring element is fixed to the installation surface without using screws and the rosette element is, in its turn, fixed to said installation surface through its fitting to the anchoring element.

35 **[0011]** The more general and advantageous configurations of the present invention are described in the Summary of the invention. Such configurations are detailed below in accordance with other advantageous and/or preferred embodiments of implementation of the present invention.

[0009] Additionally, the material making up the receiving means and the use of retention filaments ensure a secure and strong fixation between the anchoring element and the rosette element.

40 **[0012]** The screwless cover plate assembly of the present invention is adapted to be used in doors or windows, to cover the cylinder key or knob handle opening. Such assembly is projected to be installed in an installation surface of a door or window in a same manner, and it is comprised by two rosette sets arranged on opposite sides of said installation surface, in order to be aligned with the respective key cylinder or knob handle opening.

DESCRIPTION OF FIGURES**[0010]**

Figure 1 - representation of an embodiment of the screwless cover plate assembly object of the present application. The reference signs represent:

45 **[0013]** In a preferred aspect of the screwless cover plate assembly of the present invention, each rosette set comprises a rosette element (1) and an anchoring element (2). Both elements are provided with an opening (7) that is aligned with the key cylinder or knob handle opening.

50 1- rosette element;
 2 - fitting means of the rosette element;

[0014] The rosette element (1) has a first face, defining the external appearance of the set, and a second face, opposite to the first face, comprising fitting means (2) adapted to fit into an anchoring element (3).

[0015] In its turn, the anchoring element (3) has a first face facing the rosette element (1), provided with at least one perforation through which receiving means (4) are formed in a protruding manner on a second face, opposite to the first face. Additionally, in order to fix the anchoring element (3) to the installation surface, it is provided with screwless fixing means (5) provided in the second face.

[0016] More particularly, the receiving means (4) are adapted to fit into corresponding matching cavities in the installation surface so that the screwless fixing means (5) are in contact with the installation surface to fix the anchoring element (3).

[0017] The cavities are pre-installed in the installation surface and may serve as a guide in the positioning and installation of each set of rosettes.

[0018] In a preferred aspect of the cover plate assembly of the present invention, the screwless fixing means (5) are of an adhesive type, such as a double-sided adhesive strip.

[0019] In another preferred aspect of the cover plate assembly of the present application, the receiving means (4) of the anchoring element (3) are adapted to receive the fitting means (2) of the rosette element (1), so that the rosette element (1) is fixed to the installation surface through its fitting to the anchoring element (3).

[0020] Consequently, a simple way of installing a set of rosettes is achieved, without the use of screws and only through a fitting mechanism.

[0021] Additionally, in another preferred aspect of the cover plate assembly of the present application, the receiving means (4) of the anchoring element (3) are made of an elastic material and are further comprised by a plurality of retention filaments (6) adapted to expand to favour the insertion of the fitting means (2) and to contract to favour the retention of said fitting means (2) inside the receiving means (4). More particularly, the receiving means (4) being made of an elastic material, such as polyamide 6, have controlled deformation properties that allow its expansion when the fitting means (2) are inserted, and its subsequent retraction to retain the fitting means (2) inside it. Additionally, the anchoring element (3) may also be made of an elastic material, and the anchoring element (3) and the receiving means (4) may form a single piece which facilitates the manufacturing process of this element (3) and, consequently, makes it possible to further simplify the process of installing the assembly.

[0022] In another preferred aspect of the cover plate assembly of the present application, the fitting means (2) of the rosette element (1) are in the form of protuberances, more preferably being spherical pins. Additionally, the receiving means (4) are projections of the second face of the anchoring element (3), that are specially

designed to define an interior space adapted to receive the fitting means (2) of the rosette element (1). More preferably such projections have a cylindrical shape adapted to encompass the spherical pins that form the fitting means (2) of the rosette element (1).

[0023] The shape of the pin (2) is of particular relevance since, being spherical, it not only allows the coupling between the rosette (1) and the anchoring (3) elements to be carried out smoothly and easily, but also makes the area of contact with the receiving means (4) to be larger, allowing to achieve a more secure fit.

[0024] In connection with the preferred aspects already mentioned, in another preferred aspect of the cover plate assembly of the present application, the retention filaments (6) are positioned in an inner surface of the projections forming the receiving means (4) of the anchoring element (3). More preferably, said retention filaments (6) are arranged symmetrically with one another and configured in such a way as to adapt to the spherical profile of the fitting means (2), allowing the coupling of the rosette element (1) and blocking its movement in the opposite direction. The filaments (6) are made of an elastic material that is able to expand as the pin (2) enters into the receiving means (4) and to contract as the pin (2) settles into said means (4), keeping the rosette set securely in place.

[0025] In an alternative aspect of the cover plate assembly of the present invention, the number of retention filaments (6) is 3. In this way it is possible to obtain a uniform distribution of filaments (6) in the receiving means (4) along the contact surface of the fitting means (2), which favours the retention effect.

[0026] In another alternative aspect of the cover plate assembly of the present invention, the number of fitting means (2) in the rosette element (1) is equal to the number of receiving means (4) in the anchoring element (3). More particularly, the number of fitting means and receiving means is 2, providing the assembly with the appropriate dimensions for its installation in a door or window frame.

EMBODIMENTS

[0027] In a preferred embodiment of the screwless cover plate assembly of the present invention, it comprises two rosette sets arranged on opposite sides of an installation surface and aligned with the key cylinder or knob handle opening; each rosette set comprising:

- a rosette element (1) having a first face defining the external appearance of the set, and a second face, opposite to the first face, comprising fitting means (2) adapted to fit into an anchoring element (3);
- an anchoring element (3) having a first face facing the rosette element (1), provided with at least one perforation through which receiving means (4) are formed in a protruding manner on a second face, opposite to the first face; the anchoring element (3)

further comprising screwless fixing means (5) provided in the second face; wherein,

the receiving means (4) are adapted to fit into matching cavities in the installation surface so that the screwless fixing means (5) are in contact with the installation surface to fix the anchoring element (3); and the receiving means (4) are further adapted to receive the fitting means (2) of the rosette element (1), so that the rosette element (1) is fixed to the installation surface through its fitting to the anchoring element (3); and

the receiving means (4) are made of an elastic material and are further comprised by a plurality of retention filaments (6) adapted to expand to favour the insertion of the fitting means (2) and to contract to favour the retention of said fitting means (2) inside the receiving means (3).

[0028] In another preferred embodiment of the screwless cover plate assembly of the present invention, combinable with above described, the fitting means (2) of the rosette element (1) are in the form of protuberances.

[0029] In another preferred embodiment of the screwless cover plate assembly of the present invention, combinable with any above described, the receiving means (4) are projections of the second face of the anchoring element (3), said projections being designed to define an interior space adapted to receive the fitting means (2) of the rosette element (1).

[0030] In another preferred embodiment of the screwless cover plate assembly of the present invention, combinable with any above described, the protuberances defining the fitting means (2) of the rosette element (1) are spherical pins and the projections defining the receiving means (4) of the anchoring element (3) have a cylindrical shape.

[0031] In another preferred embodiment of the screwless cover plate assembly of the present invention, combinable with any above described, the retention filaments (6) are positioned in inner surface of the projections.

[0032] In another preferred embodiment of the screwless cover plate assembly of the present invention, combinable with any above described, the retention filaments (6) are arranged symmetrically with one another.

[0033] In another preferred embodiment of the screwless cover plate assembly of the present invention, combinable with any above described, the number of retention filaments (6) is 3.

[0034] In another preferred embodiment of the screwless cover plate assembly of the present invention, combinable with any above described, the number of fitting means (2) in the rosette element (1) is equal to the number of receiving means (4) in the anchoring element (3).

[0035] In another preferred embodiment of the screwless cover plate assembly of the present invention, com-

binable with any above described, the number of fitting means (2) and receiving means (4) is 2.

[0036] In another preferred embodiment of the screwless cover plate assembly of the present invention, combinable with any above described, the anchoring element (3) is made of an elastic material, preferably polyamide 6.

[0037] In another preferred embodiment of the screwless cover plate assembly of the present invention, combinable with any above described, the anchoring element (3) and the receiving means (4) form a single piece.

[0038] In another preferred embodiment of the screwless cover plate assembly of the present invention, combinable with any above described, the screwless fixing means (5) of the anchoring element (3) is a double-sided adhesive strip.

[0039] As will be clear to one skilled in the art, the present invention should not be limited to the embodiments described herein, and a number of changes are possible which remain within the scope of the present invention.

[0040] Of course, the preferred embodiments shown above are combinable, in the different possible forms, being herein avoided the repetition all such combinations.

Claims

1. A screwless cover plate assembly for a key cylinder or a knob handle spindle of a door or window, comprising two rosette sets arranged on opposite sides of an installation surface and aligned with a key cylinder or knob handle opening; each rosette set comprising:

- a rosette element (1) having a first face defining the external appearance of the set, and a second face, opposite to the first face, comprising fitting means (2) adapted to fit into an anchoring element (3);

- an anchoring element (3) having a first face facing the rosette element (1), provided with at least one perforation through which receiving means (4) are formed in a protruding manner on a second face, opposite to the first face; the anchoring element (3) further comprising screwless fixing means (5) provided in the second face; wherein,

the receiving means (4) are adapted to fit into matching cavities in the installation surface so that the screwless fixing means (5) are in contact with the installation surface to fix the anchoring element (3); and the receiving means (4) are further adapted to receive the fitting means (2) of the rosette element (1), so that the rosette element (1) is fixed to the installation surface through its

- fitting to the anchoring element (3); and the receiving means (4) are made of an elastic material and are further comprised by a plurality of retention filaments (6) adapted to expand to favour the insertion of the fitting means (2) and to contract to favour the retention of said fitting means (2).
2. Cover plate assembly according to claim 1, wherein the fitting means (2) of the rosette element (1) are in the form of protuberances.
 3. Cover plate assembly according to claims 1 or 2, wherein the receiving means (4) are projections of the second face of the anchoring element (3), said projections being designed to define an interior space adapted to receive the fitting means (2) of the rosette element (1).
 4. Cover plate assembly according to claims 2 and 3, wherein

the protuberances defining the fitting means (2) of the rosette element (1) are spherical pins; and the projections defining the receiving means (4) of the anchoring element (3) have a cylindrical shape.
 5. Cover plate assembly according to claims 3 or 4, wherein the retention filaments (6) are positioned in inner surface of the projections.
 6. Cover plate assembly according to any of the previous claims, wherein the retention filaments (6) are arranged symmetrically with one another.
 7. Cover plate assembly according to any of the previous claims, wherein the number of retention filaments (6) is 3.
 8. Cover plate assembly according to any of the previous claims, wherein the number of fitting means (2) in the rosette element (1) is equal to the number of receiving means (4) in the anchoring element (3).
 9. Cover plate assembly according to any of the previous claims, wherein the number of fitting means (2) and receiving means (4) is 2.
 10. Cover plate assembly according to any of the previous claims, wherein the anchoring element (3) is made of an elastic material.
 11. Cover plate assembly according to claim 10, wherein the anchoring element (3) and the receiving means (4) form a single piece.
 12. Cover plate assembly according to claim 10 and 11, wherein the elastic material is polyamide 6.
 13. Cover plate assembly according to any of the previous claims, wherein the screwless fixing means (5) of the anchoring element (5) is a double-sided adhesive strip.
 14. Use of the cover plate assembly of any of claims 1 to 13 on a door.
 15. Use of the cover plate assembly of any of claims 1 to 13 on a window.

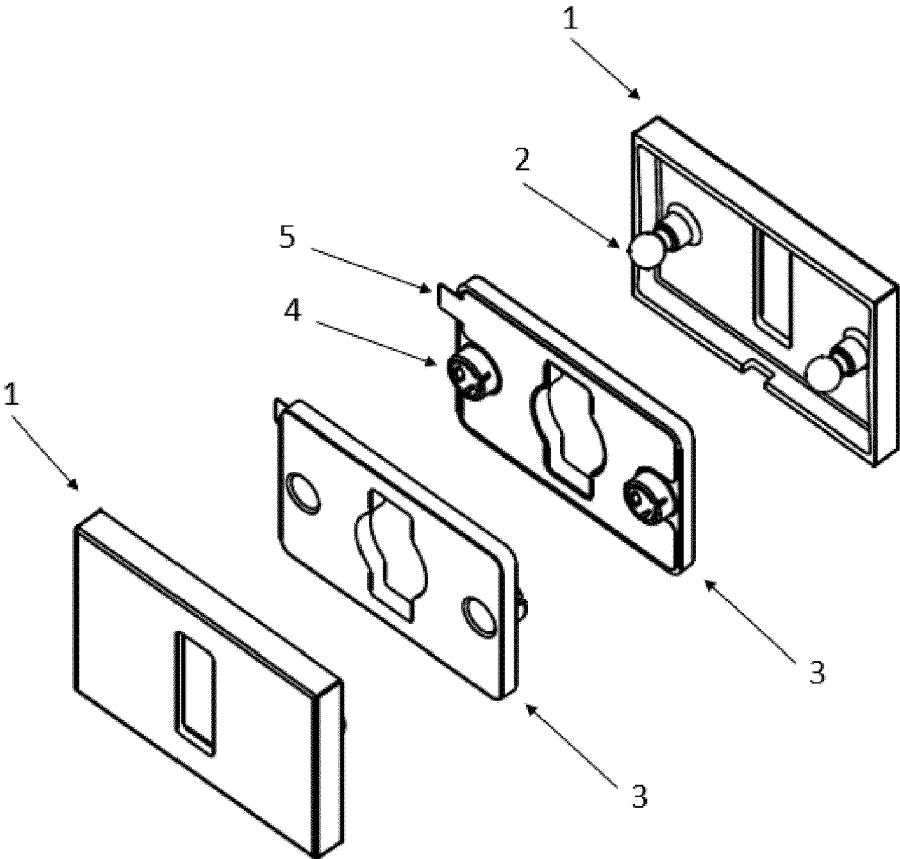

Figure 1

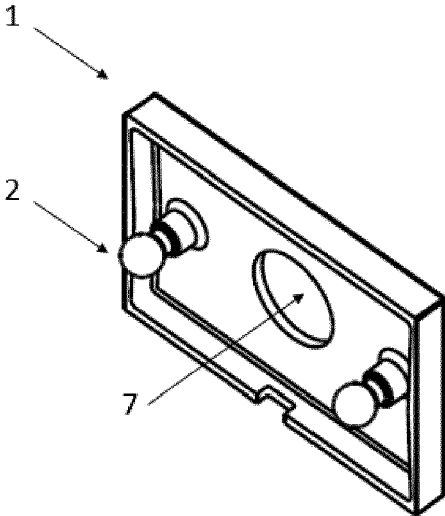

Figure 2

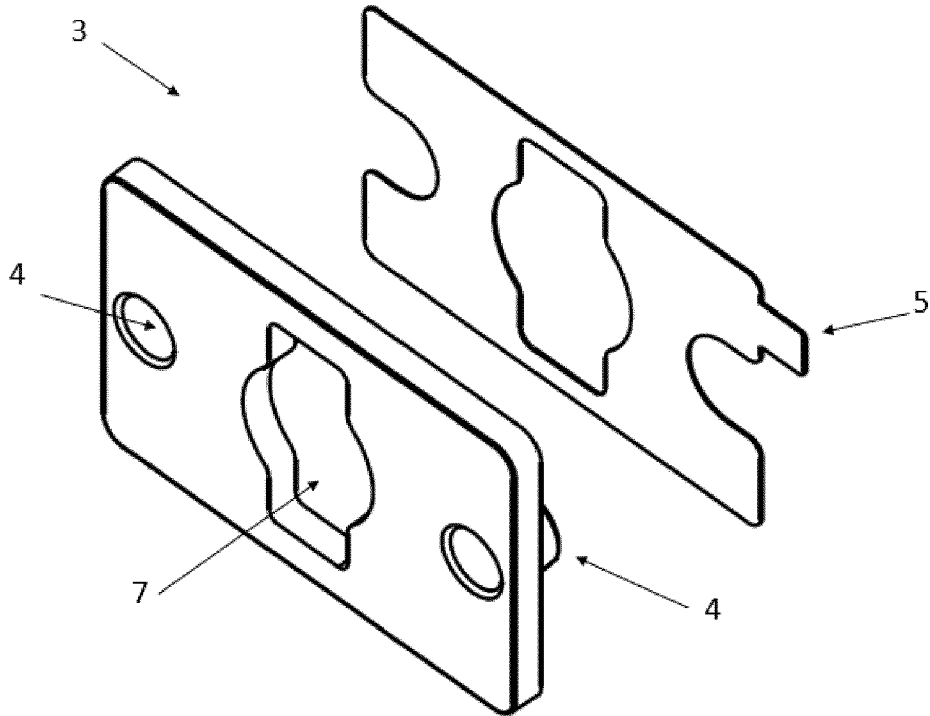

Figure 3

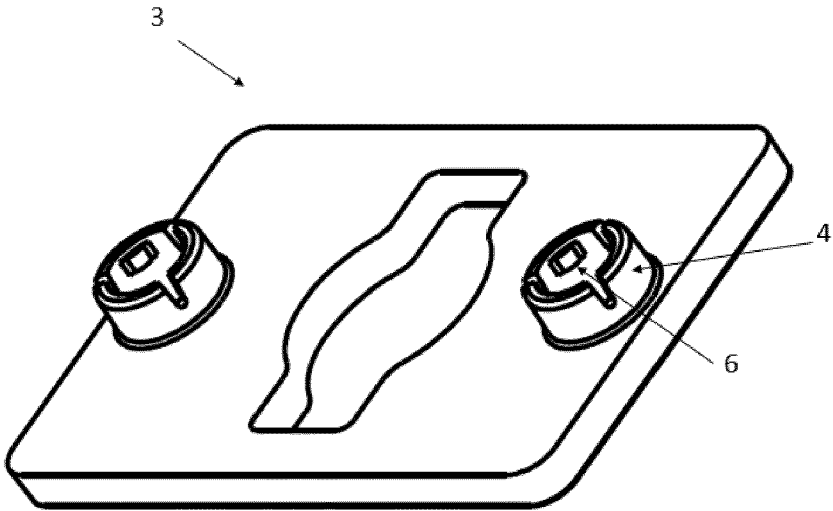

Figure 4



EUROPEAN SEARCH REPORT

Application Number
EP 23 19 0932

5

DOCUMENTS CONSIDERED TO BE RELEVANT

10

15

20

25

30

35

40

45

50

55

Category	Citation of document with indication, where appropriate, of relevant passages	Relevant to claim	CLASSIFICATION OF THE APPLICATION (IPC)
A	DE 28 37 614 A1 (EIGEMEIER WILLI) 13 March 1980 (1980-03-13) * the whole document *	1-15	INV. E05B15/02
A	DE 94 13 608 U1 (SCHNEIDER FRANZ BRAKEL GMBH [DE]) 8 December 1994 (1994-12-08) * the whole document *	1-15	
A	GB 1 291 990 A (HOLSCHER KNUD [DK]) 4 October 1972 (1972-10-04) * the whole document *	1-15	
A	FR 3 037 986 A1 (CHRISLIGNE [FR]) 30 December 2016 (2016-12-30) * the whole document *	1,10-15	
			TECHNICAL FIELDS SEARCHED (IPC)
			E05B
The present search report has been drawn up for all claims			
Place of search The Hague		Date of completion of the search 26 January 2024	Examiner Goddar, Claudia
CATEGORY OF CITED DOCUMENTS		T : theory or principle underlying the invention E : earlier patent document, but published on, or after the filing date D : document cited in the application L : document cited for other reasons & : member of the same patent family, corresponding document	
X : particularly relevant if taken alone Y : particularly relevant if combined with another document of the same category A : technological background O : non-written disclosure P : intermediate document			

1
EPO FORM 1503 03.82 (P04C01)

**ANNEX TO THE EUROPEAN SEARCH REPORT
ON EUROPEAN PATENT APPLICATION NO.**

EP 23 19 0932

5 This annex lists the patent family members relating to the patent documents cited in the above-mentioned European search report.
The members are as contained in the European Patent Office EDP file on
The European Patent Office is in no way liable for these particulars which are merely given for the purpose of information.

26-01-2024

Patent document cited in search report	Publication date	Patent family member(s)	Publication date
DE 2837614	A1	13-03-1980	NONE

DE 9413608	U1	08-12-1994	NONE

GB 1291990	A	04-10-1972	NONE

FR 3037986	A1	30-12-2016	NONE

EPO FORM P0459

For more details about this annex : see Official Journal of the European Patent Office, No. 12/82