

(19)



(11)

**EP 4 509 791 A1**

(12)

**EUROPEAN PATENT APPLICATION**

(43) Date of publication:  
**19.02.2025 Bulletin 2025/08**

(51) International Patent Classification (IPC):  
**F28D 9/00<sup>(2006.01)</sup> F28F 13/08<sup>(2006.01)</sup>**

(21) Application number: **24192741.7**

(52) Cooperative Patent Classification (CPC):  
**F28D 9/0093; F28D 9/005; F28F 13/08;  
F28F 2230/00; F28F 2270/00**

(22) Date of filing: **02.08.2024**

(84) Designated Contracting States:  
**AL AT BE BG CH CY CZ DE DK EE ES FI FR GB  
GR HR HU IE IS IT LI LT LU LV MC ME MK MT NL  
NO PL PT RO RS SE SI SK SM TR**  
Designated Extension States:  
**BA**  
Designated Validation States:  
**GE KH MA MD TN**

(72) Inventors:  
• **TOURON, Gregory  
Nordborg (DK)**  
• **ZHANG, Zhifeng  
Nordborg (DK)**

(30) Priority: **17.08.2023 CN 202311042633  
17.08.2023 CN 202322218673 U**

(74) Representative: **Patentanwälte Olbricht Buchhold  
Keulertz  
Partnerschaft mbB  
Neue Mainzer Straße 75  
60311 Frankfurt am Main (DE)**

(71) Applicant: **Danfoss A/S  
6430 Nordborg (DK)**

(54) **PLATE HEAT EXCHANGER**

(57) The present invention provides a plate heat exchanger comprising: a plurality of heat transfer plates stacked in a first direction; first and second fluid channels formed between adjacent heat transfer plates and fluidly isolated from each other; and fluid barrier structure,

which forms an isolation area in the first fluid channel so that the isolation area of the first fluid channel is fluidly isolated from the remaining areas of the first fluid channel. By adopting the fluid barrier structure, the performance of the plate heat exchanger is improved.

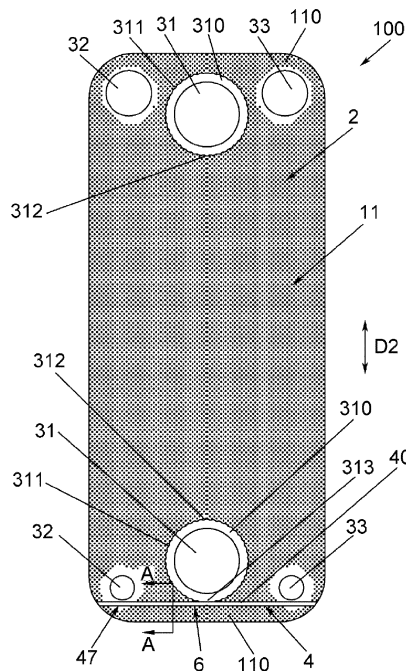

Fig.1

**EP 4 509 791 A1**

## Description

### Cross-reference to related applications

**[0001]** This application claims the priority of Chinese Patent Applications No. CN 202311042633.4 and No. CN202322218673.1 filed on August 17, 2023, the whole disclosures of which are incorporated herein by reference.

### Technical Field

**[0002]** The present invention relates to a plate heat exchanger.

### Background

**[0003]** A traditional plate heat exchanger comprises a plurality of heat transfer plates. Fluid channels used for two or more fluids are formed between adjacent heat transfer plates to conduct heat exchange between two or more fluids.

### Summary of the Invention

**[0004]** A purpose of the embodiments of the present invention is to provide a plate heat exchanger, thereby such as improving the performance of the plate heat exchanger.

**[0005]** An embodiment of the present invention provides a plate heat exchanger comprising: a plurality of heat transfer plates stacked in a first direction; first and second fluid channels formed between adjacent heat transfer plates and fluidly isolated from each other; and fluid barrier structure, which forms an isolation area in the first fluid channel so that the isolation area of the first fluid channel is fluidly isolated from the remaining areas of the first fluid channel.

**[0006]** According to an embodiment of the present invention, the fluid barrier structure is configured to surround the isolation area in the first fluid channel, or surround the isolation area in the first fluid channel together with an edge of the first fluid channel.

**[0007]** According to an embodiment of the present invention, the first fluid channel is configured to have two edge areas opposite to each other in a second direction perpendicular to the first direction, the plate heat exchanger further comprises: two first ports formed in the heat transfer plate on two opposite sides of the heat transfer plate in the second direction, respectively, and fluidly communicated to the first fluid channel; and two first annular sealing portions formed on the heat transfer plate around the two first ports, and an outer periphery of each of the two first annular sealing portions is configured to have an outer peripheral portion proximate to in the second direction a middle of the heat transfer plate in the second direction, and wherein the fluid barrier structure comprises a first fluid barrier structure that is disposed in

the first fluid channel on a side of the outer peripheral portion of the outer periphery of one of the two first annular sealing portions far away from the other one of the two first annular sealing portions in the second direction so that a corresponding one of the two edge areas is formed as an isolation area.

**[0008]** According to an embodiment of the present invention, the second direction is a vertical direction and the corresponding one of the two edge areas of the first fluid channel is a bottom or top area of the first fluid channel in a state where the plate heat exchanger is being used.

**[0009]** According to an embodiment of the present invention, the fluid barrier structure further comprises a second fluid barrier structure that is disposed in the first fluid channel on a side of the outer peripheral portion of the outer periphery of the other one of the two first annular sealing portions far away from the one of the two first annular sealing portions in the second direction so that the corresponding other one of the two edge areas is formed as an isolation area.

**[0010]** According to an embodiment of the present invention, the second direction is a vertical direction, and the two edge areas of the first fluid channel are the bottom area and the top area of the first fluid channel, respectively, in a state where the plate heat exchanger is being used.

**[0011]** According to an embodiment of the present invention, the fluid barrier structure comprises a banded fluid barrier.

**[0012]** According to an embodiment of the present invention, the first fluid barrier structure comprises a banded fluid barrier.

**[0013]** According to an embodiment of the present invention, the fluid barrier comprises a barrier strip disposed between two adjacent heat transfer plates in the first fluid channel.

**[0014]** According to an embodiment of the present invention, the fluid barrier comprises two strip-shaped protrusions that protrude towards each other from two adjacent heat transfer plates defining the first fluid channel, respectively, and that are connected to each other.

**[0015]** According to an embodiment of the present invention, the fluid barrier comprises two strip-shaped protrusions that protrude towards each other from two adjacent heat transfer plates defining the first fluid channel, respectively; and a barrier strip disposed between the two strip-shaped protrusions of the two adjacent heat transfer plates in the first fluid channel.

**[0016]** According to an embodiment of the present invention, a width of a top of the strip-shaped protrusion is in a range from 0.5 to 50 mm.

**[0017]** According to an embodiment of the present invention, a width of a top of the strip-shaped protrusion is in a range from 0.5 to 50 mm.

**[0018]** According to an embodiment of the present invention, at least one portion of the fluid barrier is configured to have a linear shape.

**[0019]** According to an embodiment of the present invention, the at least one portion of the fluid barrier is at an angle of 80-90 degrees relative to the second direction.

**[0020]** According to an embodiment of the present invention, the strip-shaped protrusion is configured to have a cross section of a circle, triangle, or trapezoid.

**[0021]** According to an embodiment of the present invention, the strip-shaped protrusion is configured to have a cross section of a circle, triangle, or trapezoid.

**[0022]** According to an embodiment of the present invention, a top of the strip-shaped protrusion is configured to have a recess.

**[0023]** According to an embodiment of the present invention, a top of the strip-shaped protrusion is configured to have a recess.

**[0024]** According to an embodiment of the present invention, the fluid barrier comprises a portion partially surrounding the one of the two first annular sealing portions.

**[0025]** According to an embodiment of the present invention, the plate heat exchanger is positioned such that the second direction is the vertical direction, and an upper edge of the first fluid barrier structure is lower than a bottom outer peripheral portion of the outer periphery of the one of the two first annular sealing portions, or the upper edge of the first fluid barrier structure is aligned with the bottom outer peripheral portion of the outer periphery of the one of the two first annular sealing portions in the second direction in a state where the plate heat exchanger is being used.

**[0026]** According to an embodiment of the present invention, the plate heat exchanger is positioned such that the second direction is the vertical direction, and the fluid barrier comprises a portion partially surrounding the one of the two first annular sealing portions and a portion with an upper edge higher than the bottom outer peripheral portion of the outer periphery of the one of the two first annular sealing portions in a state where the plate heat exchanger is being used.

**[0027]** According to an embodiment of the present invention, the plate heat exchanger further comprises: a third fluid channel formed between the adjacent heat transfer plates and fluidly isolated from the first and second fluid channels; two second ports formed in the heat transfer plate on two opposite sides of the heat transfer plate in the second direction, respectively, and fluidly communicated to the second fluid channel; and two third ports formed in the heat transfer plate on two opposite sides of the heat transfer plate in the second direction, respectively, and fluidly communicated to the third fluid channel.

**[0028]** According to an embodiment of the present invention, the plate heat exchanger further comprises: a third fluid channel formed between the adjacent heat transfer plates and fluidly isolated from the first and second fluid channels; two second ports formed in the heat transfer plate on two opposite sides of the heat

transfer plate in the second direction, respectively, and fluidly communicated to the second fluid channel; two second annular sealing portions formed on the heat transfer plate around the two second ports, respectively; two third ports formed in the heat transfer plate on two opposite sides of the heat transfer plate in the second direction, respectively, and fluidly communicated to the third fluid channel; and two third annular sealing portions formed on the heat transfer plate around the two third ports, respectively; wherein the plate heat exchanger is positioned such that the second direction is the vertical direction, and the fluid barrier comprises a portion partially surrounding the one of the two first annular sealing portions, a portion partially surrounding a corresponding one of the two second annular sealing portions, a portion partially surrounding a corresponding one of the two third annular sealing portions, and a portion with an upper edge higher than a bottom outer peripheral portion of the outer periphery of the one of the two first annular sealing portions in a state where the plate heat exchanger is being used.

**[0029]** According to an embodiment of the present invention, the plate heat exchanger further comprises: a discharge hole formed in the heat transfer plate in the second direction on the side of the fluid barrier away from the other one of the two first annular sealing portions and being in fluid communication with the first fluid channel and fluid isolation from the second fluid channel.

**[0030]** According to an embodiment of the present invention, the plate heat exchanger further comprises: a third fluid channel formed between the adjacent heat transfer plates and fluidly isolated from the first and second fluid channels; two second ports formed in the heat transfer plate on two opposite sides of the heat transfer plate in the second direction, respectively, and fluidly communicated to the second fluid channel; two third ports formed in the heat transfer plate on two opposite sides of the heat transfer plate in the second direction, respectively, and fluidly communicated to the third fluid channel; and a discharge hole formed in the heat transfer plate in the second direction on the side of the fluid barrier away from the other one of the two first annular sealing portions and being in fluid communication with the first fluid channel and fluid isolation from the second and third fluid channels.

**[0031]** According to an embodiment of the present invention, the fluid barrier structure comprises a filling material.

**[0032]** According to an embodiment of the present invention, the plate heat exchanger further comprises: two strip-shaped recesses that are recessed in a direction away from each other from two adjacent heat transfer plates defining the second fluid channel, respectively, and wherein the strip-shaped recesses of two adjacent heat transfer plates form a guiding channel.

**[0033]** According to an embodiment of the present invention, the plate heat exchanger further comprises: a strip-shaped recess formed by the strip-shaped protru-

sion of the heat transfer plate in the second fluid channel, and wherein the strip-shaped recesses of two adjacent heat transfer plates form a guiding channel.

**[0034]** According to an embodiment of the present invention, the plate heat exchanger further comprises: a strip-shaped recess formed by the strip-shaped protrusion of the heat transfer plate in the second fluid channel, and wherein the strip-shaped recesses of two adjacent heat transfer plates form a guiding channel.

**[0035]** According to an embodiment of the present invention, at least one portion of the guiding channel is configured to have a linear shape.

**[0036]** According to an embodiment of the present invention, the at least one portion of the guiding channel is at an angle of 80-90 degrees relative to the second direction.

**[0037]** According to an embodiment of the present invention, the guiding channel comprises a plurality of guiding channels arranged in the second direction.

**[0038]** According to an embodiment of the present invention, the strip-shaped recess is configured to have a plurality of portions with different widths.

**[0039]** By adopting the plate heat exchanger according to an embodiment of the present invention, the performance of the plate heat exchanger may be improved, for example, the anti-freezing performance of the plate heat exchanger may be enhanced.

#### Brief Description of the Drawings

##### [0040]

FIG. 1 is a schematic front view of a plate heat exchanger according to an embodiment of the present invention.

FIGS. 2 to 5 shows various schematic cross-sectional views of the strip-shaped protrusions of a heat transfer plate of a plate heat exchanger.

FIG. 6 is a schematic partial enlarged cross-sectional view of a plate heat exchanger according to an embodiment of the present invention.

FIG. 7 is a schematic partial enlarged cross-sectional view of a plate heat exchanger according to an embodiment of the present invention.

FIG. 8 is a schematic front view of a plate heat exchanger according to an embodiment of the present invention.

FIG. 9 is a schematic front view of a plate heat exchanger according to an embodiment of the present invention.

FIG. 10 is a schematic front view of a plate heat exchanger according to an embodiment of the present invention.

FIG. 11 is a schematic front view of a plate heat exchanger according to an embodiment of the present invention.

FIG. 12 is a schematic front view of a plate heat exchanger according to an embodiment of the present invention.

sent invention.

FIG. 13 is a schematic front view of a plate heat exchanger according to an embodiment of the present invention.

FIG. 14 is a schematic front view of a plate heat exchanger according to an embodiment of the present invention.

FIG. 15 is a schematic front view of a plate heat exchanger according to an embodiment of the present invention.

FIG. 16 is a schematic cross-sectional view of a plate heat exchanger according to an embodiment of the present invention.

#### 15 Detailed Description of the Invention

**[0041]** The present invention will be described below in further detail in conjunction with the drawings and specific embodiments.

**[0042]** Referring to FIGS. 1 to 16, a plate heat exchanger 100 according to an embodiment of the present invention comprises: a plurality of heat transfer plates 2 stacked in a first direction D1; first and second fluid channels 11, 12 formed between adjacent heat transfer plates 2 and fluidly isolated from each other; and a fluid barrier structure 4, which forms an isolation area in a first fluid channel 11 so that the isolation area of the first fluid channel 11 is fluidly isolated from the remaining areas of the first fluid channel 11. For example, the fluid barrier structure 4 is configured to surround the isolation area in the first fluid channel 11, or surround the isolation area in the first fluid channel 11 together with an edge of the first fluid channel 11. The fluid barrier structure 4 may comprise a filling material 48.

**[0043]** Referring to FIGS. 1 to 16, in an embodiment according to the present invention, the first fluid channel 11 is configured to have two edge areas or end areas 110 opposite to each other in a second direction D2 perpendicular to the first direction D1. The plate heat exchanger 100 further comprises: two first ports 31, which are formed in the heat transfer plate 2 on opposite sides of the heat transfer plate 2 in the second direction D2, and are fluidly communicated to the first fluid channel 11; and two first annular sealing portions 310 formed on the heat transfer plate 2 around the two first ports 31 respectively, and an outer periphery 311 of each of the two first annular sealing portions 310 is configured to have an outer peripheral portion 312 proximate to a middle of the heat transfer plate 2 in the second direction D2. The fluid barrier structure 4 comprises a first fluid barrier structure 4, which is disposed in the first fluid channel 11 on a side of the outer peripheral portion 312 of the outer periphery 311 of one of the two first annular sealing portions 310 far away from the other one of the two first annular sealing portions 310 in the second direction D2 so that a corresponding one of the two edge areas 110 is formed as an isolation area.

**[0044]** Referring to FIGS. 1, 8-14, in an embodiment of

the present invention, the plate heat exchanger 100 further comprises: a third fluid channel 13 formed between adjacent heat transfer plates 2 and fluidly isolated from the first and second fluid channels 11, 12; two second ports 32 formed in the heat transfer plate 2 on two opposite sides of the heat transfer plate 2 in the second direction D2, respectively, and fluidly communicated to the second fluid channel 12; two second annular sealing portions formed on the heat transfer plate 2 around the two second ports 32, respectively; two third ports 33 formed in the heat transfer plate 2 on two opposite sides of the heat transfer plate 2 in the second direction D2, respectively, and fluidly communicated to the third fluid channel 13; and two third annular sealing portions formed on the heat transfer plate 2 around the two third ports 33, respectively.

**[0045]** According to an embodiment of the present invention, as shown in FIG. 16, the first annular sealing portion 310 formed on the heat transfer plate 2 around the first port 31 fluidly isolates the second fluid channel 12 and the third fluid channel 13 from the first port 31, thereby the first port 31 is only fluidly communicated to the first fluid channel 11. The second annular sealing portion formed on the heat transfer plate 2 around the second port 32 fluidly isolates the first fluid channel 11 and the third fluid channel 13 from the second port 32, thereby the second port 32 is only fluidly communicated to the second fluid channel 12. The third annular sealing portion formed on the heat transfer plate 2 around the third port 33 fluidly isolates the second fluid channel 12 and the third fluid channel 13 from the third port 33, thus the third port 33 is only fluidly communicated to the third fluid channel 13.

**[0046]** According to the embodiment of the present invention, the first fluid channel 11 is used for a first heat exchange medium, the second fluid channel 12 is used for a second heat exchange medium, and the third fluid channel 13 is used for a third heat exchange medium. The first heat exchange medium may be liquids such as water, ethylene glycol, propylene glycol, etc., while the second and third heat exchange media may be refrigerant. According to the embodiment of the present invention, the first heat exchange medium may also be refrigerant.

**[0047]** Plate heat exchanger 100 may be a soft brazed plate heat exchanger, a hard brazed plate heat exchanger, a gasket plate heat exchanger, or any other types of plate heat exchangers. The plate heat exchanger 100 may also comprise a cover plate 71 and a bottom plate 72, and the plurality of heat transfer plates 2 are disposed between the cover plate 71 and the bottom plate 72. The plate heat exchanger 100 may be the heat exchanger shown in FIGS. 1, 8-14, or the heat exchanger shown in FIG. 15, or other types of plate heat exchangers. Plate heat exchanger 100 may also be a double-wall heat exchanger.

**[0048]** Referring to FIGS. 1, 8-15, the second direction D2 is a vertical direction and the corresponding one of the

two edge areas 110 of the first fluid channel 11, which is formed as the isolation area, is a bottom or top area of the first fluid channel 11 in a state where the plate heat exchanger 100 is being used.

**[0049]** Referring to FIG. 12, in an embodiment of the present invention, the fluid barrier structure 4 further comprises a second fluid barrier structure 4, which is disposed in the first fluid channel 11 on a side of the outer peripheral portion 312 of the outer periphery 311 of the other one of the two first annular sealing portions 310 far away from the one of the two first annular sealing portions 310 in the second direction D2 so that the corresponding other one of the two edge areas 110 is formed as an isolation area. The second fluid barrier structure 4 and the first fluid barrier structure 4 may be the same fluid barrier structure. The second direction D2 is a vertical direction, and the two edge areas 110 of the first fluid channel 11 are the bottom area and the top area of the first fluid channel 11, respectively, in a state where the plate heat exchanger 100 is being used.

**[0050]** Referring to FIGS. 1-13 and 15, in an embodiment of the present invention, the fluid barrier structure 4 or the first fluid barrier structure 4 comprises a banded fluid barrier 47. Referring to FIG. 7, according to an embodiment of the present invention, the fluid barrier 47 comprises a barrier strip 41 disposed between two adjacent heat transfer plates 2 in the first fluid channel 11. Referring to FIG. 6, according to another embodiment of the present invention, the fluid barrier 47 comprises two strip-shaped protrusions 42 that protrude towards each other from two adjacent heat transfer plates 2 defining the first fluid channel 11, respectively, and that are connected to each other. Referring to FIG. 7, according to another embodiment of the present invention, the fluid barrier 47 comprises two strip-shaped protrusions 42 that protrude towards each other from two adjacent heat transfer plates 2 defining the first fluid channel 11, respectively; and a barrier strip 41 disposed between the two strip-shaped protrusions 42 of the two adjacent heat transfer plates 2 in the first fluid channel 11. Referring to FIG. 2, a width  $T_p$  of a top 420 of the strip-shaped protrusion 42 may be in the range from 0.5 to 50 mm, 0.5 to 10 mm, or 1 to 3 mm, or other suitable dimensions. A width of the barrier strip 41 may be greater than, less than, or equal to the width  $T_p$  of the top 420 of the strip-shaped protrusion 42. Referring to FIG. 8, the width of the top 420 of the strip-shaped protrusion 42 may vary along a length of the strip-shaped protrusion 42, such as being wider and/or narrower in some portions of the length of the strip-shaped protrusion 42, as long as it may block the fluid in the first fluid channel 11. A material of the barrier strip 41 may be the same as or different from that of the heat transfer plate 2. Referring to FIGS. 2-5, the strip-shaped protrusion 42 may have a cross section of a circle, triangle, or trapezoid, or any other suitable shapes, as long as it may block the fluid in the first fluid channel 11. Referring to FIG. 5, the top 420 of the strip-shaped protrusion 42 may have a recess 421. As a result, a solder may be kept in the recess

421. Although it is shown in FIG. 7 that the fluid barrier 47 comprises the strip-shaped protrusion 42 and the barrier strip 41, the fluid barrier 47 may only comprise the barrier strip 41.

**[0051]** Referring to FIGS. 1, 8-13, and 15, in an embodiment of the present invention, at least one portion of the fluid barrier 47 is configured to have a linear shape. The at least one portion of the fluid barrier 47 is at an angle of 80-90 degrees relative to the second direction D2. The fluid barrier 47 may have a linear shape, and the fluid barrier 47 may at an angle of 80-90 degrees relative to the second direction D2. In addition, the fluid barrier 47 may have a wavy shape, a broken line shape, or other suitable shapes in length, in addition to the linear shape. The plate heat exchanger 100 is positioned such that the second direction D2 is the vertical direction, and an upper edge 40 of the first fluid barrier structure 4 is lower than a bottom outer peripheral portion 313 of the outer periphery 311 of the one of the two first annular sealing portions 310, or the upper edge 40 of the first fluid barrier structure 4 is aligned with the bottom outer peripheral portion 313 of the outer periphery 311 of the one of the two first annular sealing portions 310 in the second direction D2 in a state where the plate heat exchanger 100 is being used. In addition, the fluid barrier 47 may be horizontal or inclined. Referring to FIG. 11, a lower edge of the first fluid barrier structure 4 may be aligned with a top outer peripheral portion 314 of the outer periphery 311 of the other one of the two first annular sealing portions 310 in the second direction D2. The lower edge of the first fluid barrier structure 4 may be higher or lower than the top outer peripheral portion 314.

**[0052]** Referring to FIGS. 6 and 7, in an embodiment of the present invention, the plate heat exchanger 100 further comprises two strip-shaped recesses 49 that are recessed in a direction away from each other from two adjacent heat transfer plates defining the second fluid channel 12 or each of the second fluid channel 12 and the third fluid channel 13, respectively, and the strip-shaped recesses 49 of the two adjacent heat transfer plates 2 form a guiding channel 6. Alternatively, the plate heat exchanger 100 also comprises a strip-shaped recess 49 formed by the strip-shaped protrusion 42 of the heat transfer plate 2 in the second fluid channel 12 or in each of the second fluid channel 12 and the third fluid channel 13, and the strip-shaped recesses 49 of two adjacent heat transfer plates 2 form a guiding channel 6. At least one portion of guiding channel 6 may have a linear shape. The at least one portion of the guiding channel 6 may be at an angle of 80-90 degrees relative to the second direction. Therefore, the heat exchange medium (such as refrigerant) in the second fluid channel 12 or in each of the second fluid channel 12 and the third fluid channel 13 may flow in the guiding channel 6. Referring to FIG. 8, the width of the top 420 of the strip-shaped protrusion 42 may vary along the length of the strip-shaped protrusion 42, such as being wider and/or narrower in some portions of the length of the strip-

shaped protrusion 42. That is, the strip-shaped recess 49 has a plurality of portions with different widths. Thus, flow characteristics and heat transfer characteristics of the heat transfer medium flowing in the guiding channel 6 may be improved. Referring to FIG. 9, in an embodiment of the present invention, the guiding channel 6 comprises a plurality of guiding channels 6 arranged in the second direction D2, such as two, three, or more guiding channels 6. The cross sections of the plurality of guiding channels 6 may be the same or different.

**[0053]** Referring to FIG. 10, in an embodiment of the present invention, the fluid barrier 47 comprises a portion 43 partially surrounding the one of the two first annular sealing portions 310. According to an embodiment of the present invention, the plate heat exchanger 100 is positioned such that the second direction D2 is the vertical direction, and the fluid barrier 47 comprises a portion 43 partially surrounding the one of the two first annular sealing portions 310 and a portion 44 with an upper edge 40 higher than the bottom outer peripheral portion 313 of the outer periphery 311 of the one of the two first annular sealing portions 310 in a state where the plate heat exchanger 100 is being used. For example, the fluid barrier 47 comprises a portion 43 partially surrounding the one of the two first annular sealing portions 310, a portion 45 partially surrounding a corresponding one of the two second annular sealing portions, a portion 46 partially surrounding a corresponding one of the two third annular sealing portions, and a portion 44 with an upper edge 40 higher than the bottom outer peripheral portion 313 of the outer periphery 311 of the one of the two first annular sealing portions 310. According to the embodiment of the present invention, it is possible to prevent or reduce the accumulation of the first fluid in the area between the second port 32 located in a lower part of the heat exchange plate and the left edge of the heat exchange plate, and to prevent or reduce the accumulation of the first fluid in the area between the third port 33 located in the lower part of the heat exchange plate and the right edge of the heat exchange plate. Referring to FIG. 13, in an embodiment of the present invention, the plate heat exchanger 100 further comprises a discharge hole 5 formed in the heat transfer plate 2 on the side of the fluid barrier 47 away from the other one of the two first annular sealing portions 310 in the second direction D2, which is in fluid communication with the first fluid channel 11 and fluid isolation from the second fluid channel 12. In the example shown in FIG. 13, the discharge hole 5 is fluidly communicated to the first fluid channel 11 and fluidly isolated from the second fluid channel 12 and the third fluid channel 13. The plate heat exchanger 100 may comprise one or more discharge holes 5, which may be used for leak detection in production lines or applications. In the production process, if the fluid barrier fails, the heat exchange medium may flow into the edge area, causing freezing problems during use. Therefore, the fault may be checked through the discharge hole, which may be connected to an application pipeline sys-

tem or covered with an insulation material during application.

**[0054]** Although the above embodiments describe the fluid barrier structure 4 is disposed in the first fluid channel 11, the fluid barrier structure 4 may also be disposed in at least one of the second fluid channel 12 and the third fluid channel 13, or disposed in each of the first fluid channel 11, second fluid channel 12, and third fluid channel 13. In addition, the area and size of the fluid barrier structure 4 in each of the fluid channels may be the same or different. For example, in some fluid channels, the fluid barrier is narrower, while in other fluid channels, the fluid barrier is wider.

**[0055]** Referring to FIG. 14, in an embodiment of the present invention, the first fluid barrier structure 4 comprises a filling material 48. The filling material 48 comprises solid material or liquid material that is then cured. For example, after completing the brazing of the plate heat exchanger 100, an adhesive is filled in the edge area 110 (top and/or bottom area) of at least one of the first fluid channel 11, second fluid channel 12, and third fluid channel 13 to provide a blocking effect. The adhesive may be epoxy resin. The filling material 48 may also be low melting point metal or alloy, oil, wax, plastic, or any type of liquid.

**[0056]** According to an embodiment of the present invention, due to the fact the fluid barrier structure 4 is disposed in the bottom area of the first fluid channel 11, when the heat exchange medium (such as water) is discharged from the first fluid channel 11 in case of the plate heat exchanger 100 being not used (such as in winter or at low ambient temperatures), there is less heat exchange medium remained in the bottom area of the first fluid channel 11, or there is no heat exchange medium remained in the bottom area of the first fluid channel 11, thereby avoiding freezing or static freezing at low temperatures. There is no or very little heat exchange at the bottom of the second fluid channel 12 or the bottoms of the second fluid channel 12 and the third fluid channel 13 since the fluid barrier structure 4 is disposed in the bottom area of the first fluid channel 11. Therefore, a large amount of vaporized gas after heat exchange will not be generated, which may promote a distribution of the second fluid in the second fluid channel 12 or distributions of the second fluid in the second fluid channel 12 and the third fluid in the third fluid channel 13. In addition, due to the formation of a guiding channel 6 in the second fluid channel 12 or in the second fluid channel 12 and the third fluid channel 13, the heat transfer medium (such as refrigerant) in the second fluid channel 12 or in the second fluid channel 12 and the third fluid channel 13 is more uniformly distributed, especially for plate heat exchangers with larger widths (the dimensions in a third direction perpendicular to the first and second directions). Furthermore, there will be little or no heat transfer in the edge area 110 (bottom and/or top area) since the fluid barrier structure 4 is disposed in the first fluid channel 11, which may avoid dynamic freezing during the heat

transfer. In addition, for certain applications, setting the fluid barrier structure 4 in the edge area 110 (bottom and/or top area) of the first fluid channel 11 does not have a negative impact on a heat transfer efficiency, but may reduce an amount of the heat transfer medium (such as refrigerant) filled therein. In addition, the formation of the isolation area in fluid channels through the fluid barrier structure may reduce the amount of the heat transfer medium (such as refrigerant) filled therein.

**[0057]** According to an embodiment of the present invention, the fluid barrier structure is disposed in the heat transfer plate without any additional cost or process, which is easy to be implemented on a product. In addition, the strip-shaped protrusion 42 of the fluid barrier structure is disposed in the first fluid channel 11 and the guiding channel 6 is formed in the second fluid channel 12, thereby improving the heat transfer efficiency and compensating for a decrease in a heat transfer area. Furthermore, the fluid barrier structure has no impact on the user.

**[0058]** Although the present invention has been described in conjunction with embodiments, it is not limited to the aforementioned embodiments. For example, some embodiments and some technical features in all embodiments may be combined to form new embodiments.

## Claims

1. A plate heat exchanger comprising:
  - a plurality of heat transfer plates stacked in a first direction;
  - first and second fluid channels formed between adjacent heat transfer plates and fluidly isolated from each other; and
  - fluid barrier structure, which forms an isolation area in the first fluid channel so that the isolation area of the first fluid channel is fluidly isolated from the remaining areas of the first fluid channel.
2. The plate heat exchanger according to claim 1, wherein the fluid barrier structure is configured to surround the isolation area in the first fluid channel, or surround the isolation area in the first fluid channel together with an edge of the first fluid channel.
3. The plate heat exchanger according to claim 1, wherein the first fluid channel is configured to have two edge areas opposite to each other in a second direction perpendicular to the first direction,
  - the plate heat exchanger further comprises:
    - two first ports formed in the heat transfer plate on two opposite sides of the heat transfer plate in the second direction, re-

spectively, and fluidly communicated to the first fluid channel; and  
two first annular sealing portions formed on the heat transfer plate around the two first ports, and an outer periphery of each of the two first annular sealing portions is configured to have an outer peripheral portion proximate to in the second direction a middle of the heat transfer plate in the second direction, and

wherein the fluid barrier structure comprises a first fluid barrier structure that is disposed in the first fluid channel on a side of the outer peripheral portion of the outer periphery of one of the two first annular sealing portions far away from the other one of the two first annular sealing portions in the second direction so that a corresponding one of the two edge areas is formed as an isolation area.

4. The plate heat exchanger according to claim 3, wherein the second direction is a vertical direction and the corresponding one of the two edge areas of the first fluid channel is a bottom or top area of the first fluid channel in a state where the plate heat exchanger is being used.
5. The plate heat exchanger according to claim 1 wherein the fluid barrier comprises a barrier strip disposed between two adjacent heat transfer plates in the first fluid channel, or the fluid barrier comprises two strip-shaped protrusions that protrude towards each other from two adjacent heat transfer plates defining the first fluid channel, respectively, and that are connected to each other.
6. The plate heat exchanger according to claim 5, wherein a top of the strip-shaped protrusion is configured to have a recess.
7. The plate heat exchanger according to claim 1, wherein the fluid barrier comprises a portion partially surrounding the one of the two first annular sealing portions.
8. The plate heat exchanger according to any one of claims 3 to 4, wherein the plate heat exchanger is positioned such that the second direction is the vertical direction, and an upper edge of the first fluid barrier structure is lower than a bottom outer peripheral portion of the outer periphery of the one of the two first annular sealing portions, or the upper edge of the first fluid barrier structure is aligned with the bottom outer peripheral portion of the outer periphery of the one of the two first annular sealing portions in the second direction in a state where the plate heat

exchanger is being used.

9. The plate heat exchanger according to claim 1, wherein the plate heat exchanger is positioned such that the second direction is the vertical direction, and the fluid barrier comprises a portion partially surrounding the one of the two first annular sealing portions and a portion with an upper edge higher than the bottom outer peripheral portion of the outer periphery of the one of the two first annular sealing portions in a state where the plate heat exchanger is being used.

10. The plate heat exchanger according to claim 1, further comprising:

a third fluid channel formed between the adjacent heat transfer plates and fluidly isolated from the first and second fluid channels;

two second ports formed in the heat transfer plate on two opposite sides of the heat transfer plate in the second direction, respectively, and fluidly communicated to the second fluid channel;

two second annular sealing portions formed on the heat transfer plate around the two second ports, respectively;

two third ports formed in the heat transfer plate on two opposite sides of the heat transfer plate in the second direction, respectively, and fluidly communicated to the third fluid channel; and two third annular sealing portions formed on the heat transfer plate around the two third ports, respectively;

wherein the plate heat exchanger is positioned such that the second direction is the vertical direction, and the fluid barrier comprises a portion partially surrounding the one of the two first annular sealing portions, a portion partially surrounding a corresponding one of the two second annular sealing portions, a portion partially surrounding a corresponding one of the two third annular sealing portions, and a portion with an upper edge higher than a bottom outer peripheral portion of the outer periphery of the one of the two first annular sealing portions in a state where the plate heat exchanger is being used.

11. The plate heat exchanger according to claim 1, further comprising:

a discharge hole formed in the heat transfer plate in the second direction on the side of the fluid barrier away from the other one of the two first annular sealing portions and being in fluid communication with the first fluid channel and fluid isolation from the second fluid channel.

12. The plate heat exchanger according to any one of

claims 1 to 4, wherein the fluid barrier structure comprises a filling material.

- 13.** The plate heat exchanger according to claim 1, further comprising: 5  
two strip-shaped recesses that are recessed in a direction away from each other from two adjacent heat transfer plates defining the second fluid channel, respectively, and wherein the strip-shaped recesses of two adjacent heat transfer plates form a guiding channel. 10
- 14.** The plate heat exchanger according to claim 5, further comprising:  
a strip-shaped recess formed by the strip-shaped protrusion of the heat transfer plate in the second fluid channel, and wherein the strip-shaped recesses of two adjacent heat transfer plates form a guiding channel. 15  
20
- 15.** The plate heat exchanger according to any one of claims 13 to 14, wherein the strip-shaped recess is configured to have a plurality of portions with different widths. 25

25

30

35

40

45

50

55



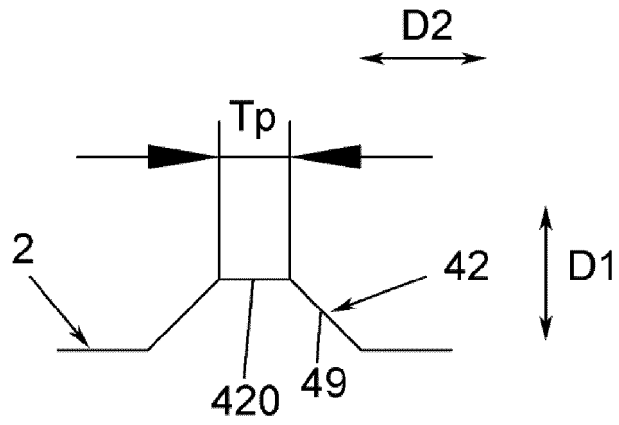

Fig.2

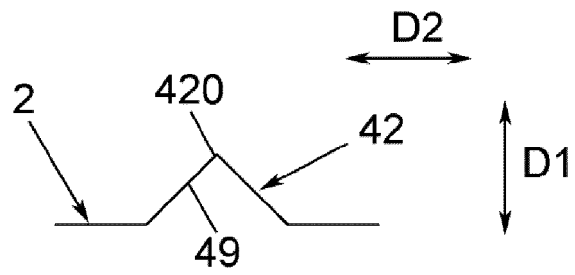

Fig.3

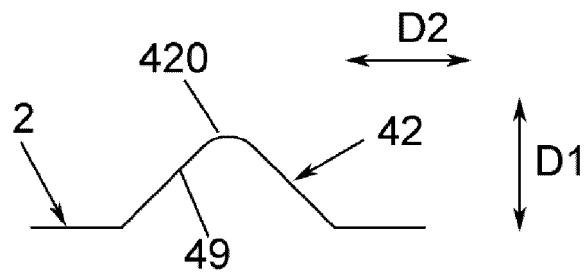

Fig.4

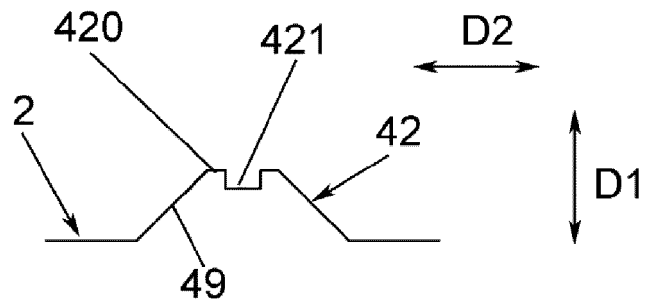

Fig.5

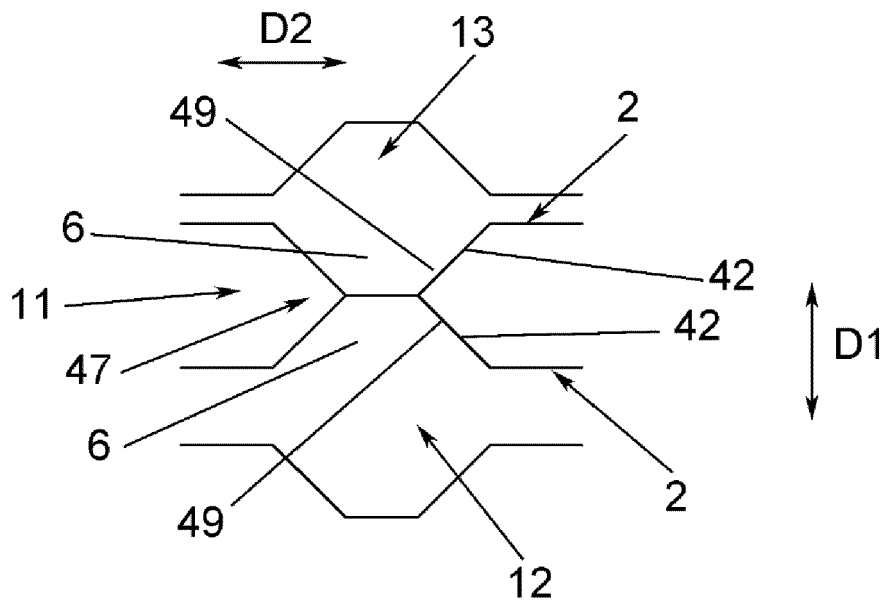

Fig.6

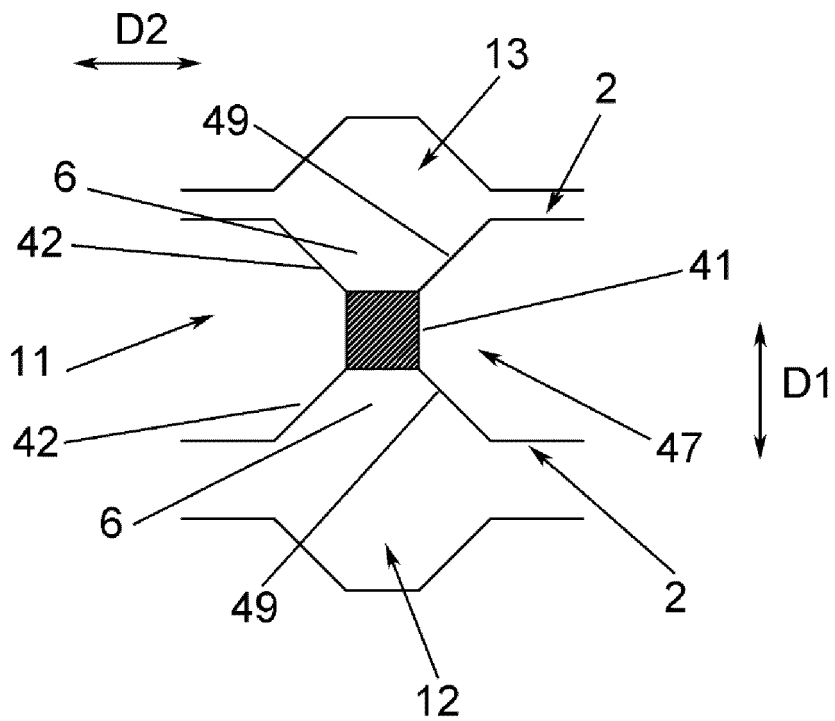

Fig.7

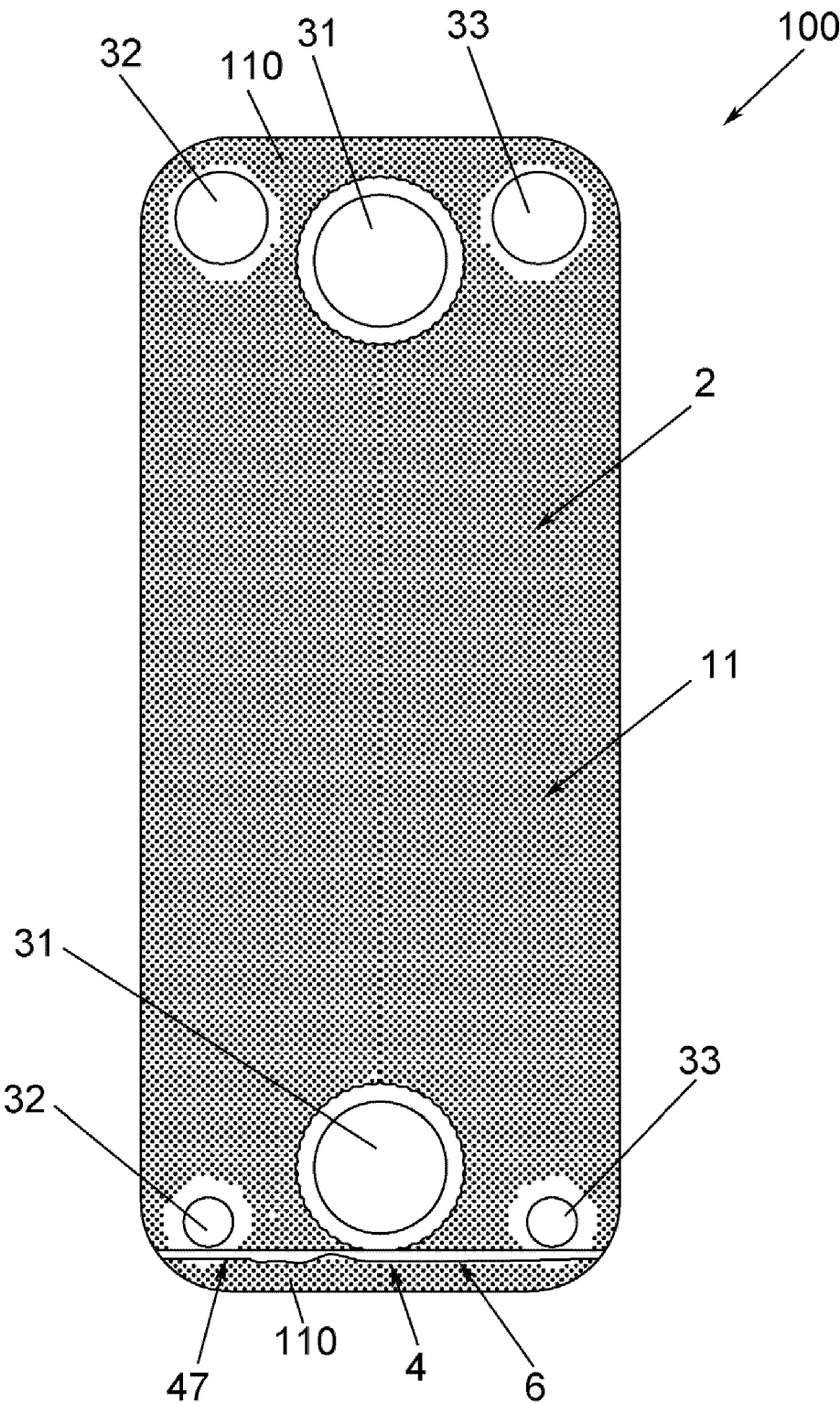

Fig.8

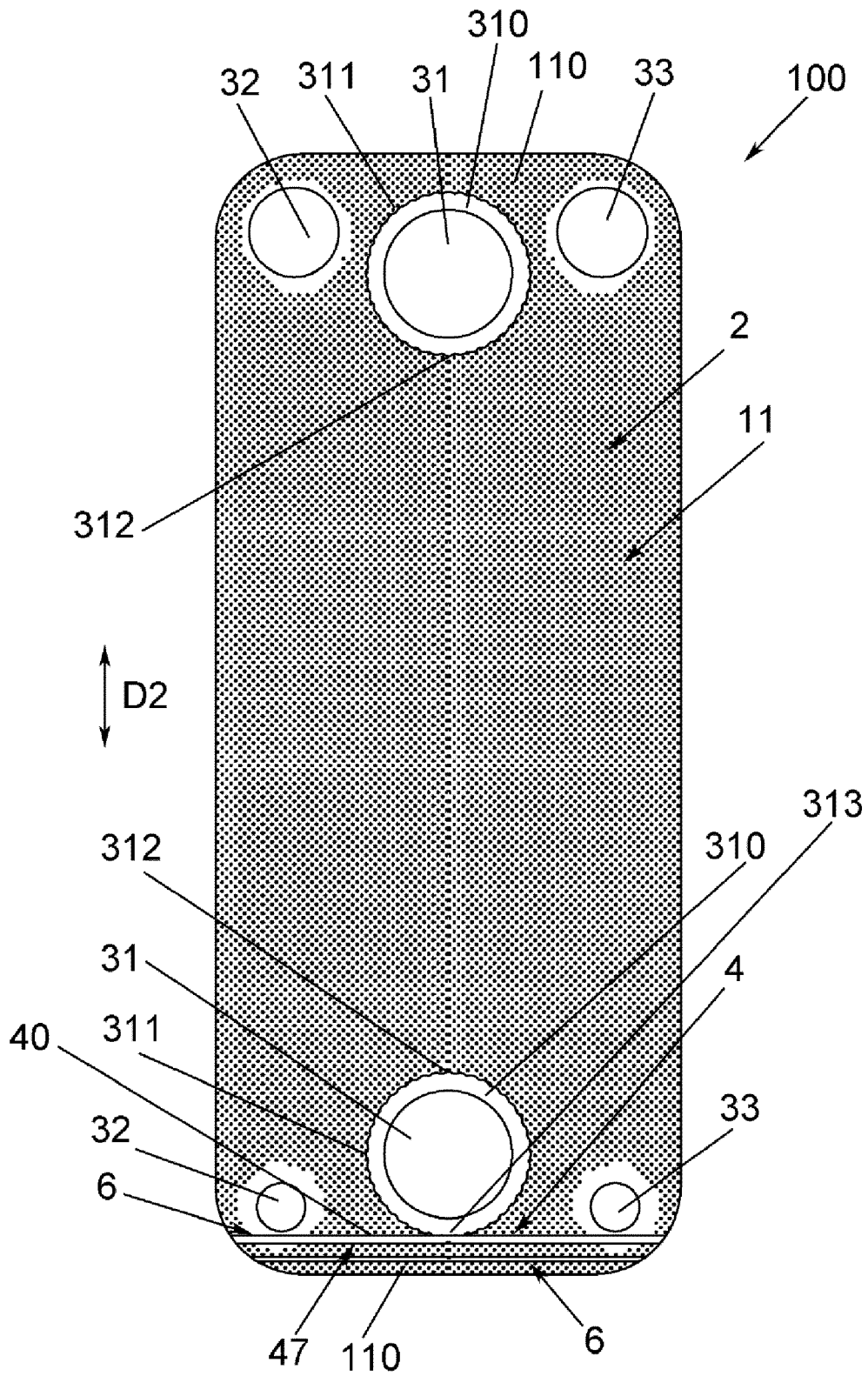

Fig.9

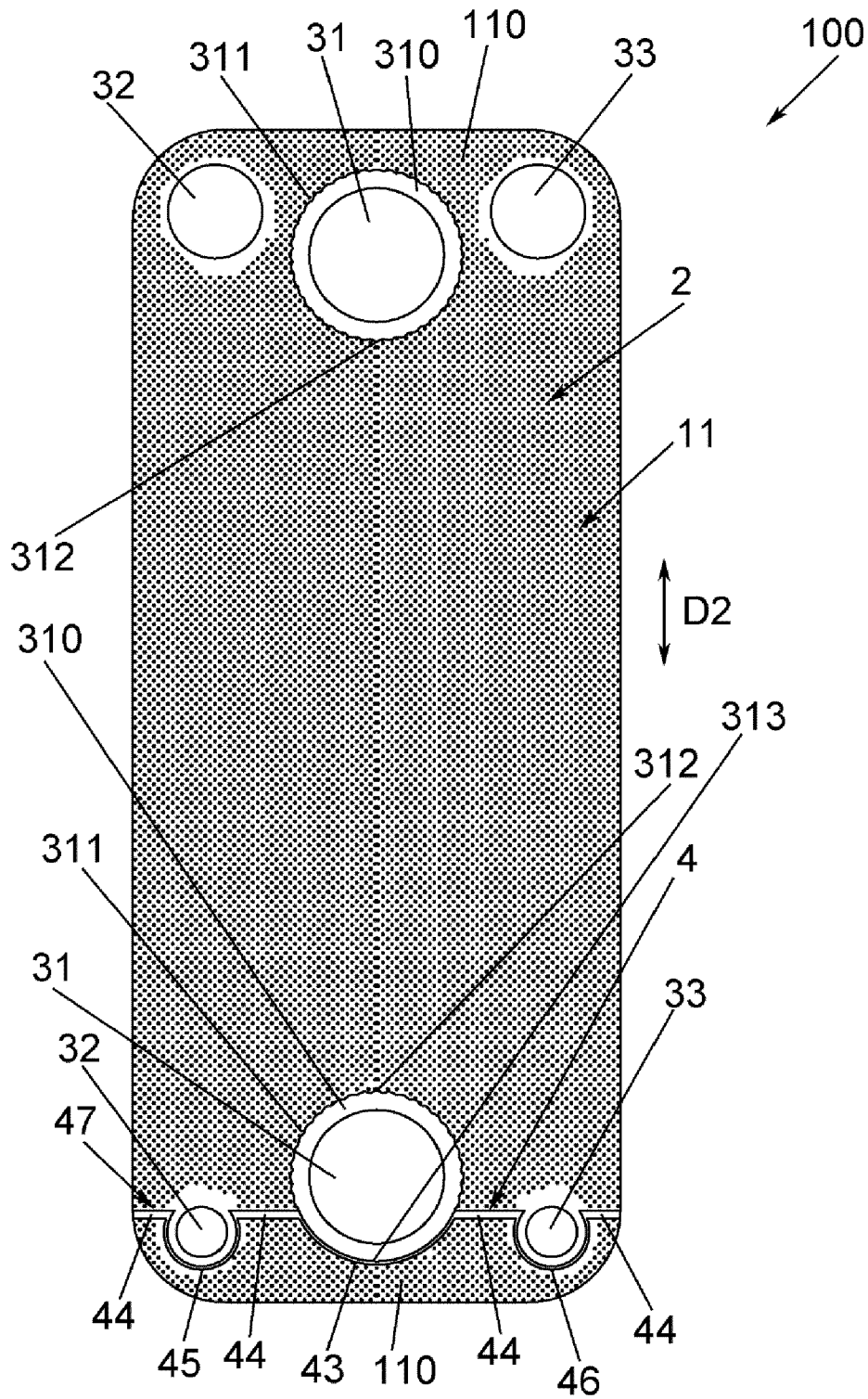

Fig.10

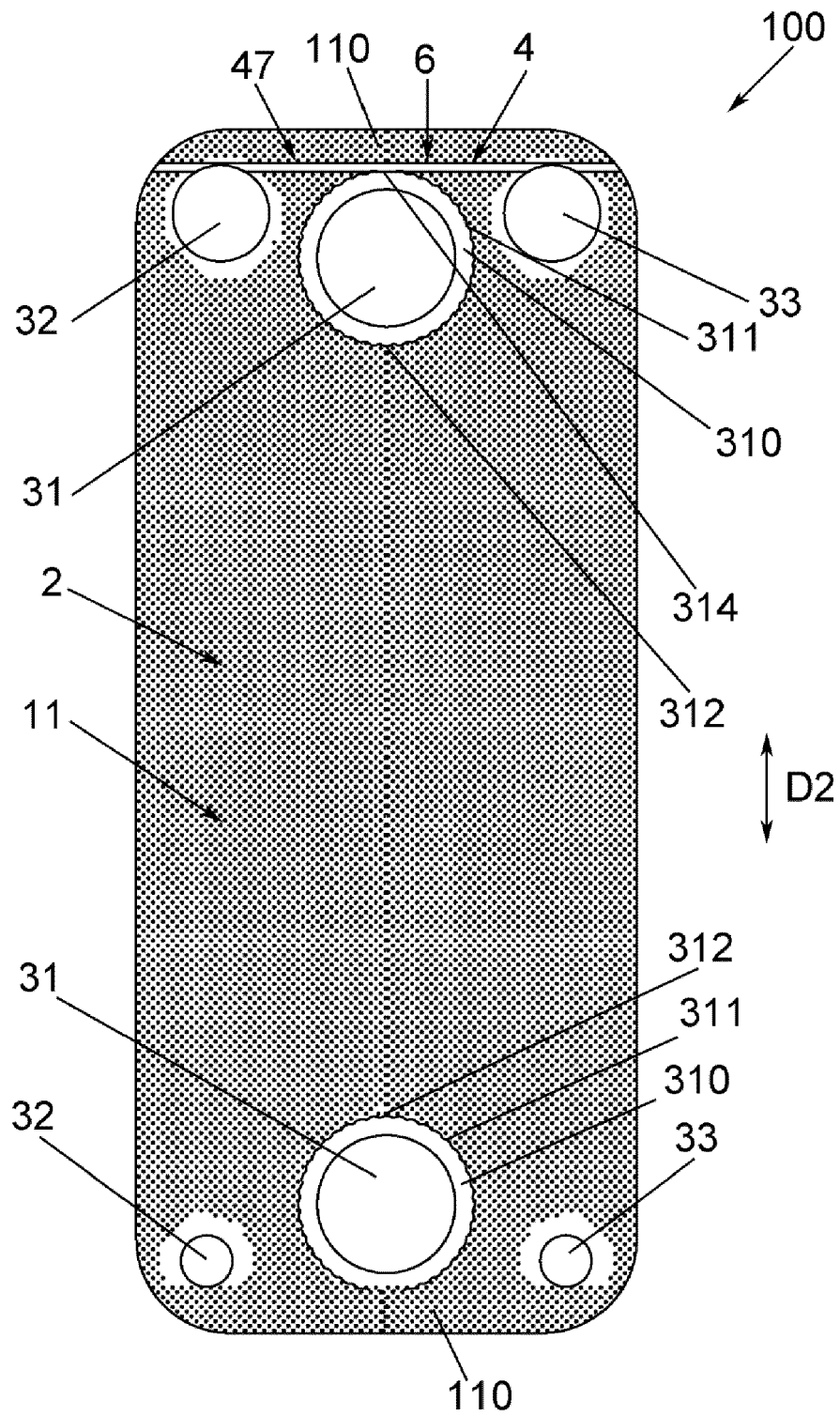

Fig.11

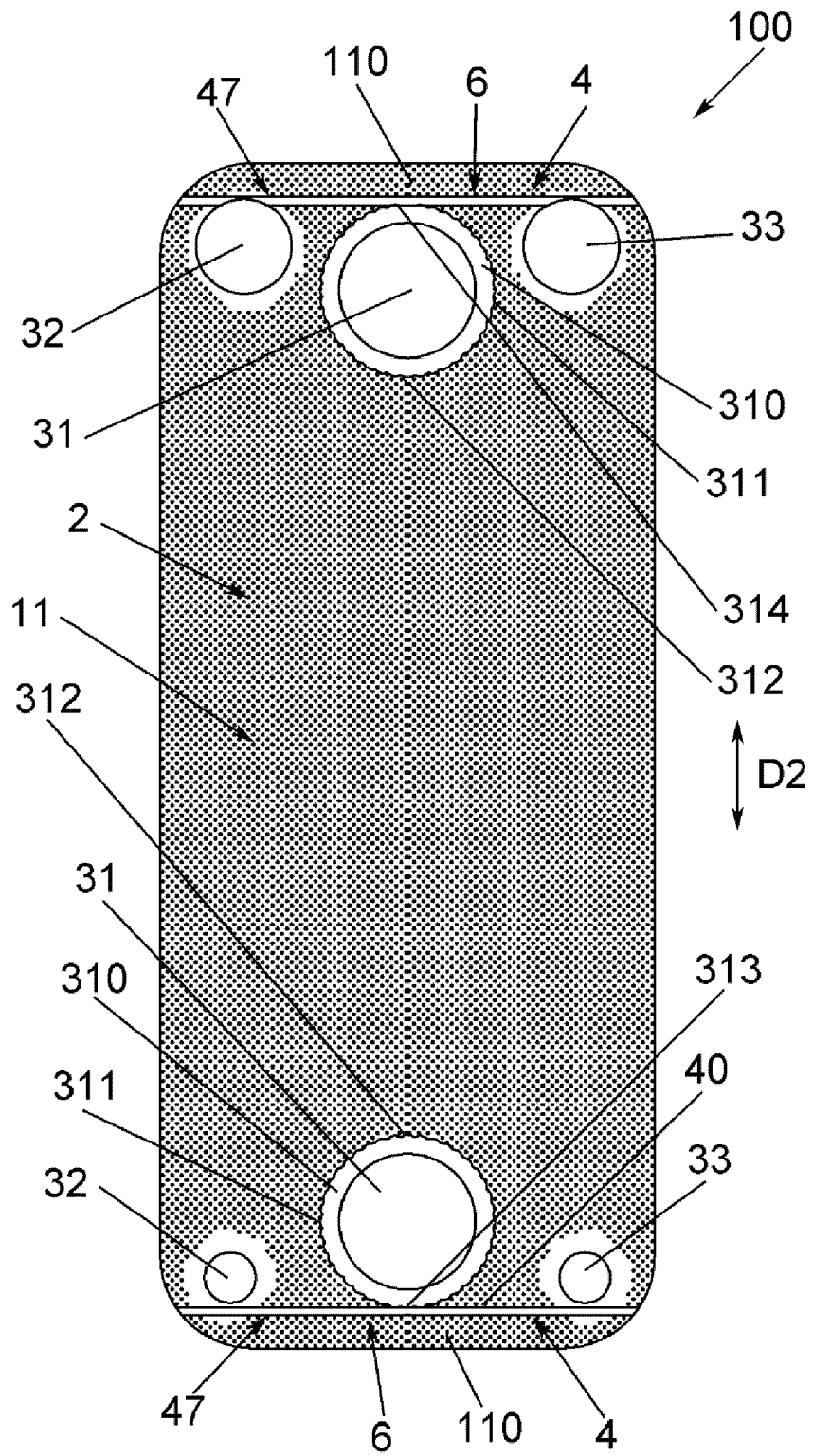

Fig.12

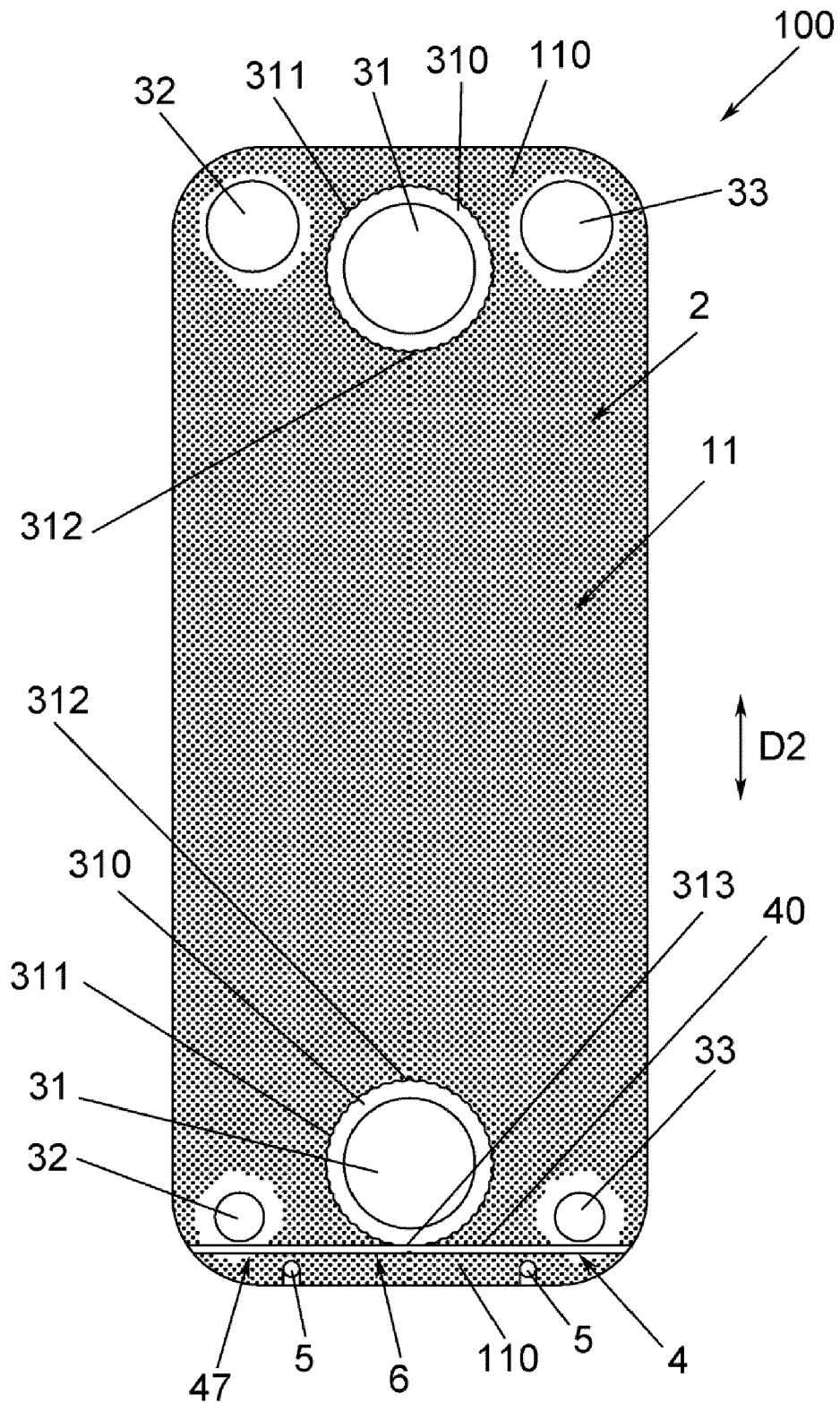

Fig.13

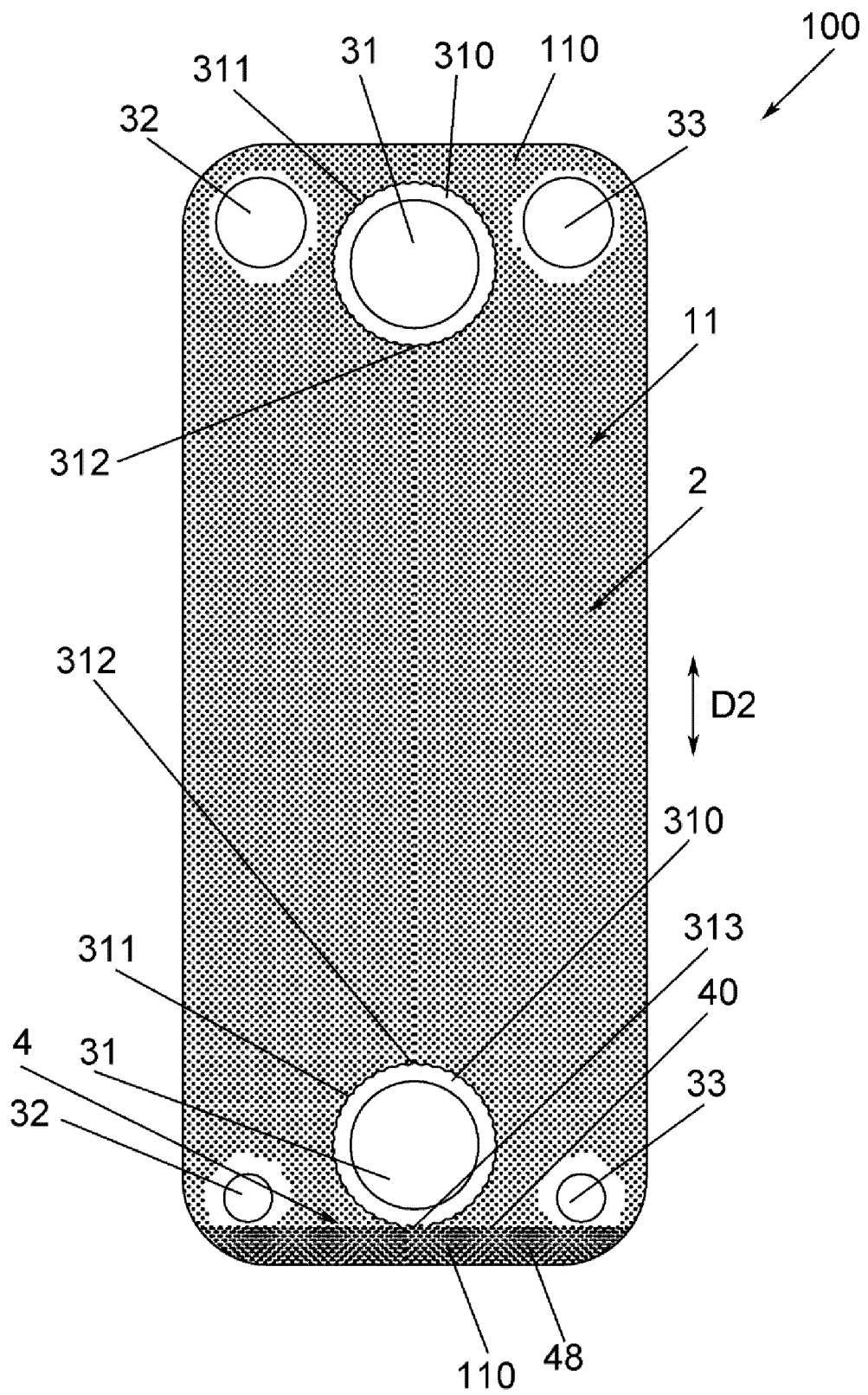

Fig.14

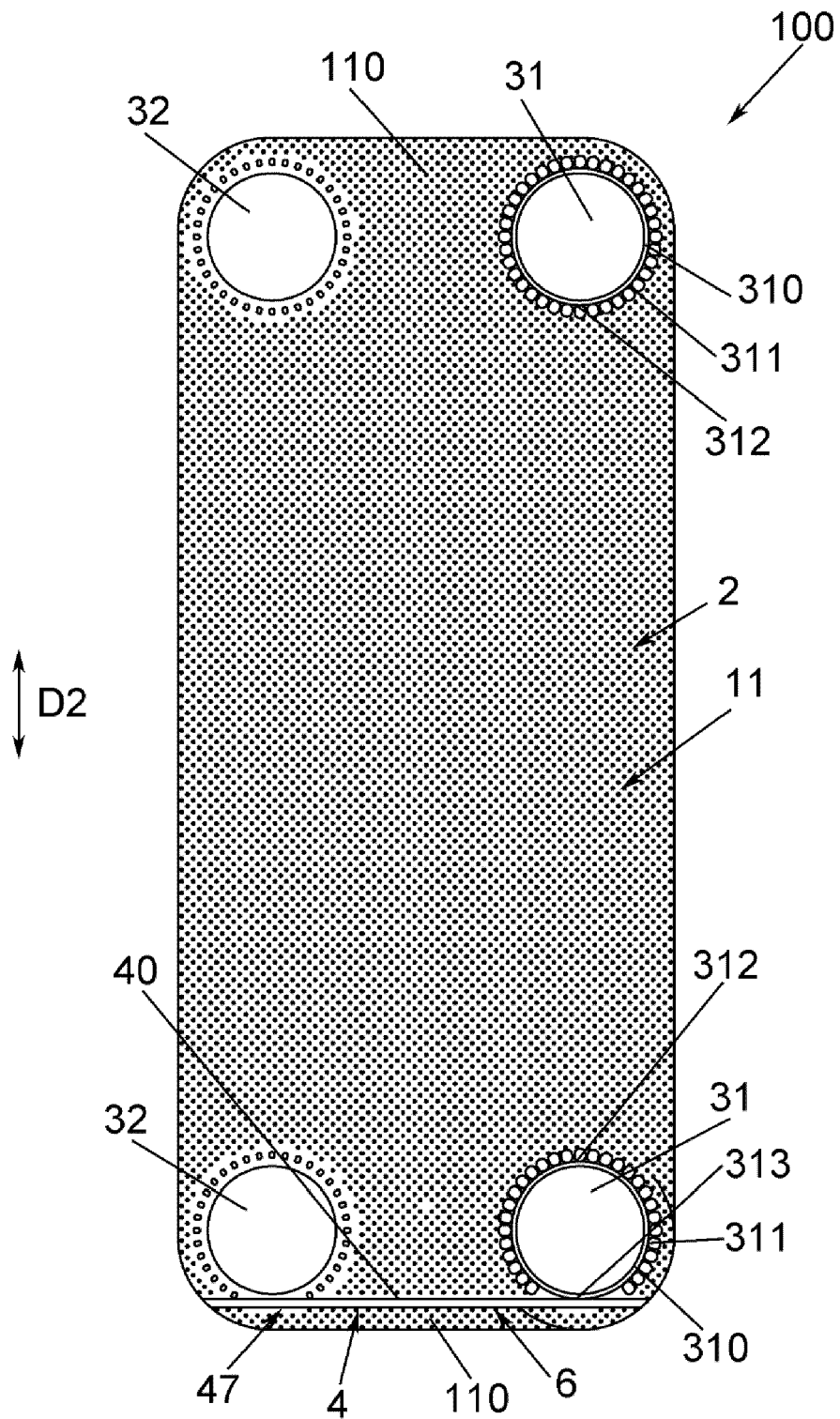

Fig.15

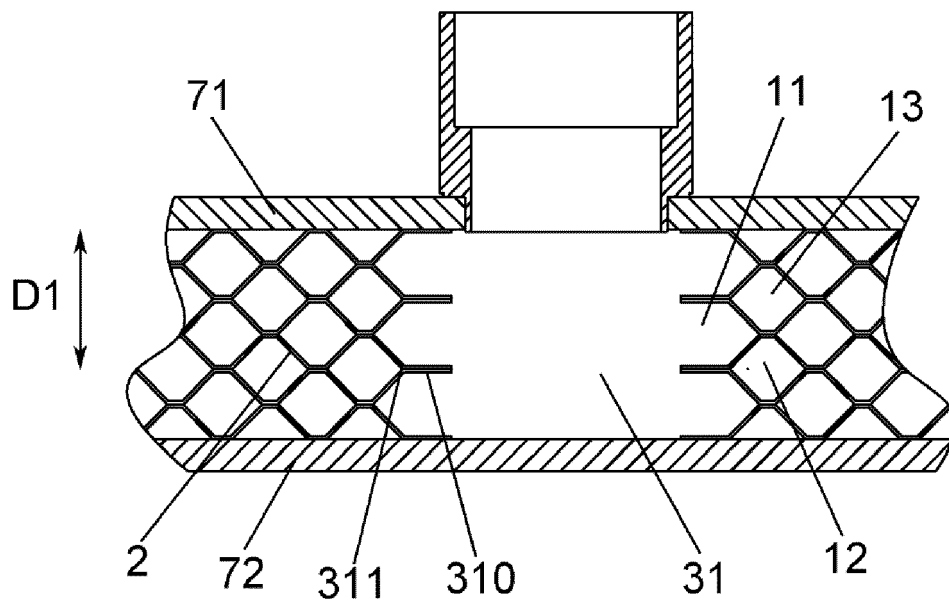

Fig.16



EUROPEAN SEARCH REPORT

Application Number  
EP 24 19 2741

5

10

15

20

25

30

35

40

45

50

55

DOCUMENTS CONSIDERED TO BE RELEVANT			
Category	Citation of document with indication, where appropriate, of relevant passages	Relevant to claim	CLASSIFICATION OF THE APPLICATION (IPC)
X A	US 2020/173695 A1 (DAHLBERG TOMAS [SE] ET AL) 4 June 2020 (2020-06-04) * the whole document *	1-5,11 6-10, 12-15	INV. F28D9/00 F28F13/08
X A	US 2023/037668 A1 (DAHLBERG TOMAS [SE] ET AL) 9 February 2023 (2023-02-09) * the whole document *	1-5,11 6-10, 12-15	
X A	US 11 300 366 B2 (SWEP INT AB [SE]) 12 April 2022 (2022-04-12) * the whole document *	1-5,11 6-10, 12-15	
X	CN 105 066 729 A (UNIV GUANGDONG TECHNOLOGY) 18 November 2015 (2015-11-18) * figures 1-10 *	1	
X	US 10 605 534 B2 (DANFOSS MICRO CHANNEL HEAT EXCHANGER JIAXING CO LTD [CN]) 31 March 2020 (2020-03-31) * the whole document *	1	TECHNICAL FIELDS SEARCHED (IPC) F28F F28D
The present search report has been drawn up for all claims			
Place of search <b>Munich</b>		Date of completion of the search <b>6 December 2024</b>	Examiner <b>Bloch, Gregor</b>
CATEGORY OF CITED DOCUMENTS X : particularly relevant if taken alone Y : particularly relevant if combined with another document of the same category A : technological background O : non-written disclosure P : intermediate document		T : theory or principle underlying the invention E : earlier patent document, but published on, or after the filing date D : document cited in the application L : document cited for other reasons ..... & : member of the same patent family, corresponding document	

1  
EPO FORM 1503 03.82 (P04C01)

ANNEX TO THE EUROPEAN SEARCH REPORT  
ON EUROPEAN PATENT APPLICATION NO.

EP 24 19 2741

5

This annex lists the patent family members relating to the patent documents cited in the above-mentioned European search report. The members are as contained in the European Patent Office EDP file on  
The European Patent Office is in no way liable for these particulars which are merely given for the purpose of information.

06-12-2024

10

15

20

25

30

35

40

45

50

55

Patent document cited in search report	Publication date	Patent family member(s)	Publication date
US 2020173695 A1	04-06-2020	CN 110709653 A	17-01-2020
		EP 3631322 A1	08-04-2020
		JP 7022445 B2	18-02-2022
		JP 2020521100 A	16-07-2020
		KR 20200010357 A	30-01-2020
		KR 20230003600 A	06-01-2023
		SE 1750634 A1	23-11-2018
		US 2020173695 A1	04-06-2020
US 2023037668 A1	09-02-2023	WO 2018215425 A1	29-11-2018
		CN 114945790 A	26-08-2022
		EP 4097414 A1	07-12-2022
		JP 2023512439 A	27-03-2023
		KR 20220133907 A	05-10-2022
		SE 2050097 A1	31-07-2021
		US 2023037668 A1	09-02-2023
		WO 2021154154 A1	05-08-2021
US 11300366 B2	12-04-2022	CN 110720021 A	21-01-2020
		EP 3631341 A1	08-04-2020
		JP 7214953 B2	31-01-2023
		JP 2020521099 A	16-07-2020
		KR 20200011453 A	03-02-2020
		US 2020173736 A1	04-06-2020
		WO 2018215426 A1	29-11-2018
		CN 105066729 A	18-11-2015
US 10605534 B2	31-03-2020	CN 102980328 A	20-03-2013
		EP 2929273 A1	14-10-2015
		KR 20150108823 A	30-09-2015
		US 2015300743 A1	22-10-2015
		WO 2014090102 A1	19-06-2014

EPO FORM P0459

For more details about this annex : see Official Journal of the European Patent Office, No. 12/82

**REFERENCES CITED IN THE DESCRIPTION**

*This list of references cited by the applicant is for the reader's convenience only. It does not form part of the European patent document. Even though great care has been taken in compiling the references, errors or omissions cannot be excluded and the EPO disclaims all liability in this regard.*

**Patent documents cited in the description**

- CN 202311042633 [0001]
- CN 202322218673 [0001]