

(19)



(11)

EP 4 521 025 A1

(12)

EUROPEAN PATENT APPLICATION

(43) Date of publication:
12.03.2025 Bulletin 2025/11

(51) International Patent Classification (IPC):
F24C 15/20^(2006.01)

(21) Application number: **23196227.5**

(52) Cooperative Patent Classification (CPC):
F24C 15/2042

(22) Date of filing: **08.09.2023**

(84) Designated Contracting States:
AL AT BE BG CH CY CZ DE DK EE ES FI FR GB GR HR HU IE IS IT LI LT LU LV MC ME MK MT NL NO PL PT RO RS SE SI SK SM TR
Designated Extension States:
BA
Designated Validation States:
KH MA MD TN

(72) Inventors:

- **Hatzenberger, Aurélien**
67270 Wilwisheim (FR)
- **Jellimann, Jérémy**
67300 Schiltigheim (FR)
- **Siefer, Marc**
67520 Marlenheim (FR)

(71) Applicant: **ARPA SASU**
67350 Niedermodern (FR)

(74) Representative: **Patentanwälte**
Ruff, Wilhelm, Beier, Dauster & Partner mbB
Kronenstraße 30
70174 Stuttgart (DE)

(54) COOKING HOB, SYSTEM COMPRISING A COOKING HOB AND A WORKTOP, AND METHOD OF INSTALLING SUCH A COOKING HOB IN A WORKTOP

(57) A cooking hob comprises a hob plate with several heating devices underneath, a suction opening in the hob plate and a suction device under the hob plate, which suction device is connected to the suction opening in an air-guiding manner. The suction device comprises an outlet device connected in air-guiding manner to the suction device and projecting laterally in a horizontal direction below the hob plate from the suction device. The outlet device is designed to be detachable from the

suction device and having two parts, namely a connecting part for connection to the suction device, and a discharge part leading into the open, in particular through an opening and behind a piece of kitchen furniture below a worktop in which the cooking hob is inserted. The connecting part is elastic and deformable, wherein the discharge part is designed to be rigid and non-deformable. This serves to compensate for any tolerance between the position of the discharge part relative to the opening.

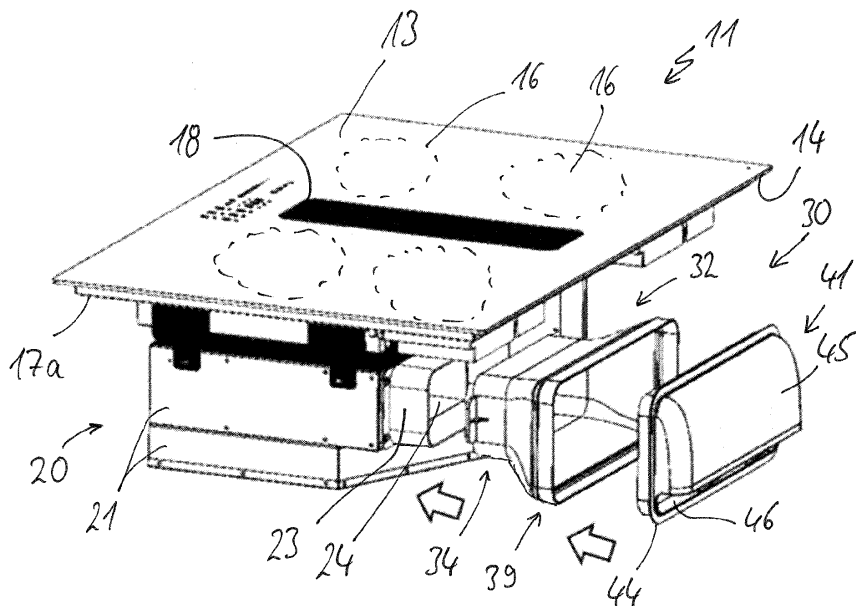

Fig. 1

EP 4 521 025 A1

Description

Technical Field and prior art

[0001] The invention is directed to a cooking hob and to a system comprising such a cooking hob and a worktop. The invention is also directed to a method of installing such a cooking hob in a worktop having an opening for the cooking hob or a housing of it, respectively, such that the result is a system mentioned before.

[0002] It is known from EP 3 869 107 B1 to combine a cooking hob with a suction device for removing cooking fumes from this cooking hob. The air is then filtered and blown out, preferably behind the suction device or behind any furniture that the cooking hob is mounted above.

Summary of the Invention

[0003] It is the object of the invention to provide a cooking hob and a system comprising a cooking hob and a worktop as well as a method of installing such a cooking hob in a worktop with which problems of the prior art can be avoided and in particular air can be blown out of the cooking hob efficiently and the cooking hob being mounted in the worktop in an easy way.

[0004] This object is solved by a cooking hob with the features of claim 1, by a system comprising such a cooking hob and a worktop with the features of claim 13 and by a method for operating such a circuit system with the features of claim 16. Advantageous and preferred configurations of the invention are the subject of the further claims and are explained in more detail below. Some of the features may be described only with regard to the cooking hob or the system or only with regard to the method. However, independent and regardless of this, they are intended to be able to apply by themselves for the cooking hob and for the system and for the method for the installation of the cooking hob independently of one another. The wording of the claims is made to the content of the description by means of express references.

[0005] A cooking hob according to the invention comprises a hob plate, wherein several heating devices are placed on and/or under this hob plate. A suction opening is provided in the hob plate or next to the hob plate. In the first case, the suction opening can be placed within an outer edge of the hob plate and at a distance of at least 2 cm therefrom. Preferably the suction opening may be located in a central region of the hob plate. A suction device is provided or mounted under the hob plate, which suction device is connected to the suction opening in an air-guiding manner for suction of steam and of exhaust air from cooking processes on the hob plate downwards. This is basically known in the art from so-called down-drafts. The suction device has or comprises an outlet device, which outlet device is connected in air-guiding manner to the suction device such that any air leaving the suction device is led away by and in the outlet device. This connection can preferably be such that no tools are

needed for connecting and for de-connecting both, the outlet device being designed to be detachable from the suction device, in particular in plug-in manner or in similar manner. The outlet device projects laterally and in a substantially horizontal direction below the plane of the hob plate from the suction device, which might also be at a small angle.

[0006] The outlet device has two parts, namely a connecting part for connection to the suction device, and a discharge part. The discharge part leads into the open or lets air out of the suction device, in particular into or behind a piece of kitchen furniture below a worktop in which the cooking hob is inserted. It is preferred to lead the air out of any furniture below the worktop, in particular behind the furniture, such that any person standing in front of the cooking hob will not be effected and will not notice anything of this air flow. This is also true if, despite any filter in the suction device, the air does still smell of cooking fumes. The connecting part is elastic and/or deformable, which may be either due to its material and/or due to its shape or construction. The discharge part is designed to be rigid and/or non-deformable, which may also be either due to its material and/or due to its shape or construction.

[0007] The aspect of the division between the suction device and the outlet device has the advantage that both parts can be special and focused on their specific purpose, where the suction device can be provided with one of several outlet devices. The outlet devices can be adapted to the situation where the cooking hob is to be installed. The aspect of the division within the suction device between the connecting part and the discharge part has the advantage that also both parts can be special and focused on their specific purpose. The elastic and/or flexible or deformable connecting part can compensate tolerances between relative positions and may also facilitate the connection to the suction device. The rigid and/or non-deformable discharge part may facilitate a connection to a wall of a piece of furniture or the like.

[0008] In an embodiment of the invention, the connecting part and the discharge part are manufactured separately as two parts, wherein both parts are connected to one another. The parts may in particular be detachably connected to one another, preferably in non-positively manner. The connection should also be such that no tools are needed for connecting and for de-connecting them both. In an alternative embodiment, both parts can be manufactured in one part, for example by a two-component injection moulding. The two materials with the properties mentioned before can also be used in such a process.

[0009] In a further embodiment of the first alternative, the connecting part and the discharge part are firmly connected to one another by being plugged one into the other. The elastic and/or deformable connecting part may preferably enclose or engage around the rigid and/or non-deformable discharge part at least in an encompassing manner. It may in particular enclose or engage around

the discharge part in a sealed manner. The connecting part may in a similar way be affixed to the suction device.

[0010] The connecting part may consist of an elastomer with a hardness between 50 and 90 Shore A, preferably between 60 and 75 Shore A, even more preferably between 68 and 72 Shore A. This provides sufficient elasticity of the connecting part. The elasticity of the connecting part can be even enhanced by providing it with at least one bellows on one of its ends, preferably on or near an end that is to be connected to the discharge part. Such a bellows can have a length of between 0,5 cm and 2 cm. It is a constructional measure to make the connecting part more flexible than only by means of the material.

[0011] The discharge part consists of a rigid or only slightly flexible plastic, preferably a thermoplastic such as polyamide. Its hardness should be considerably higher than the hardness of the connecting part such that in particular any flexibility of the outlet device is only in the connecting part. The hardness or rigidity of the discharge part can be even enhanced by providing it with at least one reinforcing rib or plate on one of its ends or between both ends. Such a reinforcing rib or plate is preferably provided at the free end of the discharge part. Said free end has a discharge opening, which discharge opening at least may protrude through the wall as mentioned before.

[0012] In a refinement of the invention, the connecting part may be connected to the suction device by fitting into one another and/or in a force-locking manner. The connecting part may preferably be fastened or affixed to an outlet opening of the suction device by means of an elastic sleeve on one free end of the connecting part. This elastic sleeve may overlap or surround a short tubular extension or the like forming the outlet opening.

[0013] In a further refinement of the invention, the suction device may extend within the vertical projection of the cooking hob and not protrude over it in lateral or horizontal direction, respectively. The outlet device may then project laterally beyond this vertical projection of the cooking hob, in particular with at least a part of the discharge part or its discharge opening, respectively. This serves to be able to discharge the air behind a furniture wall as mentioned before.

[0014] The cooking hob may have, on the underside of the hob plate, a hob housing to accommodate and enclose at least the heating devices, wherein these are arranged such that they are affixed or pressed against an underside of the hob plate as is known in the art. The hob housing extends within the vertical projection of the hob plate at a distance of at least 1 cm from an outer edge of the hob plate, preferably between 1.5 cm and 4 cm away from the outer edge, such that the hob plate extends over the hob housing. The suction device should not extend over the vertical projection of said hob housing to not protrude in horizontal direction over it. The connecting part may then also be within the vertical projection of the hob housing, such that only the discharge part

projects laterally beyond said vertical projection of the hob housing. This means that the outlet device is part within this vertical projection and part outside, wherein the discharge opening is then outside the vertical projection.

[0015] In an embodiment of the invention, the outlet device is situated above a plane forming an underside of the extraction device and/or the outlet device is situated below a plane forming an upper side of the extraction device or below an underside of a receiving housing of the cooking hob, respectively. Such a receiving housing may accommodate a hob control and a power supply of the cooking hob, wherein further functional units may be arranged therein.

[0016] In a further embodiment of the invention, an air guide cross-section of the outlet device may increase from the connection to the suction device to the discharge opening of the discharge part, preferably increase monotonically. The discharge part may in particular have a larger air guide cross-section at least in the transition to the connecting part than the connecting part in the transition to the suction device. This air guide cross-section may be 20% to 150% larger, preferably 70% to 120% larger.

[0017] The direction of the air or air flow, respectively, in the outlet device can be deflected or changed from substantially horizontal at an inlet from the suction device into the outlet device to obliquely downwards or vertically downwards at a discharge opening of the discharge part.

This serves to bring the air away from a worktop surface in which the cooking hob is inserted. The discharge opening may have an air guide cross-section amounting to 20% to 50%, in particular amounting to 30% to 40%, of an air guide cross-section in the transition from the connecting part to the discharge part, where preferably the air guide cross-section of the outlet device is largest. Even more preferably the air guide cross-section of the discharge opening may be even smaller than the air guide cross-section in the transition to the suction device, in particular amount to 70% to 90% of it.

[0018] In preferred manner, air guide plates can be provided in the discharge part, which air guide plates run in the direction of the air flow and preferably extend as far as a discharge opening of the discharge part. They may also serve as reinforcing parts or ribs mentioned before. Preferably two to four such air guide plates can be provided in the discharge part, wherein in particular they may extend in vertical direction over an entire air guide cross-section of the discharge part. This provides better stability and better guidance for the air flow.

[0019] In an embodiment of the invention, the discharge part has at least one projection or more projections projecting outwardly from the discharge part, that define a vertical plane. Alternatively, the at least one projection may run in such a vertical plane. This at least one projection may be provided in a region of the largest extension or the largest cross-section of the discharge part, preferably rather close to the outer free end. Such a

projection may in particular in be the manner of a circumferential bearing rib or flange on the outside of the discharge part. It may serve as a mechanical stop for the discharge part at the furniture wall to assist a placement in an exact location and position.

[0020] A system according to the invention comprises a cooking hob described above and a worktop having an installation opening therein. The installation opening should be smaller than the cooking hob, preferably mainly smaller than the hob plate and larger than a hob housing of the cooking hob and the suction device without the outlet device. This worktop including the installation opening may be as is known in the art.

[0021] In preferred manner, a wall, in particular a furniture wall that should be vertical, is arranged in a region below the hob plate or lower than the hob plate. It should form the back wall of a piece of furniture underneath the worktop, for example a floor cupboard. The wall should have an opening through which a part of the outlet device may extend. Preferably, the discharge part only extends with a part of the discharge part having a discharge opening, such that the discharge opening is largely on the other side of the wall than the suction device, preferably completely. The discharge opening may point at least partially downwards at an angle between 0° and 45° to the vertical. This serves to blow out air behind and downwards from a user of the cooking hob. In other specific embodiments, it may be necessary to blow the air upwards, in which case the outlet device can also do this with the discharge opening pointing upwards at an angle between 0° and 45° to the vertical.

[0022] In an embodiment of the invention, a stencil can be provided around the opening in the wall in the form of a frame. This stencil has a central opening corresponding to the outer cross-section of the discharge part, preferably at the connection to the connecting part. The central opening is smaller than the opening in the wall, preferably with a smaller height, preferably 70% to 90%, but with a corresponding width or the same width. The stencil has a frame around the central opening and said frame has on one side a width amounting to 30% to 70%, preferably 40% to 60%, of a width on the opposing side, such that the two opposing sides have a different width. These two opposing sides should be the upper side and the lower side in the mounted state. The stencil may be mounted to the opening in the wall or between the wall and the discharge part such that it makes the opening in the wall smaller to fit to the discharge part, but to also fit in the vertical height. Due to the two sides with different width, either one of may be provided as the upper side due to the vertical position of the discharge part as an additional adaptation. This may for example be preferred where the opening in the wall of the furniture is always provided at the same vertical height, but where different worktop plates with different thickness may be used. This will be described with reference to a figure later on.

[0023] A method of installing such a cooking hob as described before in a worktop as described before to form

a system as described before may start with pre-assembling the cooking hob with the outlet device mounted to the suction device. The worktop should be provided with the installation opening, which installation opening is smaller than the hob plate of the cooking hob. Then the completely pre-assembled cooking hob with the outlet device mounted to the suction device is brought from above to this installation opening in the worktop. In a subsequent step, the cooking hob is first inserted into the installation opening with an outer region, on which outer region the outlet device protrudes laterally, so it preferably is the backside. The cooking hob is inclined downwards during this movement with an initially vertical movement and then with a rotated or pivoted movement, in which rotated or pivoted movement the edge of the cooking hob opposite the outlet device is moved further downwards than the outlet device itself. This provides for the rotation. It furthermore provides for at least one end of the outlet device or the discharge part to be guided in this pivoted movement under an edge of the installation opening on the worktop. Finally the cooking hob is fixed accurately to or in the installation opening in a final end position of the cooking hob. In this end position of the cooking hob, at least the outlet device extends vertically below an edge of the installation opening, preferably the rear edge.

[0024] A vertical wall, in particular a wall of an underbuilt furniture, is provided under the worktop, wherein a through opening is provided in the vertical wall and corresponds to a vertical outer transverse sectional area of the outlet device or of the discharge part. The outlet device or the discharge part is then moved into this through opening in a pivoting manner when the cooking hob is installed in the worktop as described before. The outlet device or the discharge part protrudes through this through opening over said vertical wall, wherein it may preferably protrude at least to a large extent with a discharge opening on the discharge part. This discharge opening should be completely behind the vertical wall.

[0025] These and further features may be gathered from the claims and also from the description and the drawings, with the individual features being capable of being implemented in each case by themselves or severally in the form of sub-combinations in an embodiment of the invention and in other fields and being capable of constituting advantageous and independently patentable versions for which protection is claimed here. The subdivision of the application into individual sections and intermediate headings does not restrict the general validity of the statements made under these.

Brief Description of the Drawings

[0026] In the following, embodiments of the invention will be described in detail with reference to the drawings. Throughout the drawings, the same elements will be denoted by the same reference numerals.

- Fig. 1 a perspective view onto a cooking hob according to the invention with an outlet device shown partially in exploded view,
- Fig. 2 the cooking hob according to Fig. 1 in a pre-assembled state before mounting into a worktop,
- Fig. 3 the outlet device according to Fig. 1 with both parts separated, in a view from behind,
- Fig. 4 a first step of mounting the cooking hob according to Fig. 2 into a worktop with an installation opening,
- Fig. 5 a following step after Fig. 5 with the outermost end of the outlet device inserted into a wall opening of furniture underneath the worktop,
- Fig. 6 the cooking hob in its final position in the worktop forming a system according to the invention,
- Fig. 7 a schematic view similar to Figs. 5 and 6 of moving the outermost end of the outlet device into the wall opening with alignment,
- Fig. 8 a view similar to Fig. 8 without an alignment, where a flexible connecting part of the outlet device is deformed for the outlet device to fit into the wall opening,
- Fig. 9 an oblique sectional view of the system according to Fig. 6, and
- Fig. 10 a view similar to Fig. 9 with a different viewing angle and a stencil placed between the discharge part and discharge flange and the wall with the wall opening,
- Fig. 11 an oblique view onto the stencil according to Fig. 10.

Detailed description of the embodiments

[0027] Fig. 1 shows in an oblique view a cooking hob 11 according to the invention, the cooking hob 11 having a hob plate 13 with an underside 14, preferably made from glass ceramic material. Underneath the hob plate 13, four induction heating coils 16 are shown in dashed lines, which are housed in a hob housing 17a. This is a construction of a conventional cooking hob as is common in the art.

[0028] In a central region of the hob plate 13, a long and rectangular suction opening 18 is provided, which preferably is arranged approximately equidistant to the induction heating coils 16. Underneath the suction opening 18 and connected with it in air-guiding manner as is known in the art, a suction device 20 inside a suction housing 21 is provided. Inside the suction device 20, at least one fan is provided inside a kind of air channel or suction channel, respectively. As this is also known in the art, no details need to be given to this. The suction device 20 has a suction outlet 23 at the right side, which is the backside in an installed state of the cooking hob 11, which is shown in Figs. 6 and 9 hereinafter. The suction outlet 23 has the form of a short tube or channel having rectangular

cross-section with widely rounded corner regions and made from thin but rigid material, preferably from plastic material. A suction outlet opening 24 is provided, preferably across its total cross-section.

[0029] An outlet device 30 is provided for being connected or affixed, respectively, to the suction outlet 23. The outlet device 30 has two parts, which is a connecting part 32 on the one hand and a discharge part 41 on the other hand. The connecting part 32 has a small region 34 with a small sleeve 37 for fixing to the suction outlet 23 of the suction device 20, preferably by imposing or slipping over this suction outlet 23. The connecting part 32 is made from elastic material as is explained at the beginning, preferably made from silicone with elastic properties as mentioned above. It fits with the small region 34 in tight manner over the suction outlet 23 with an overlap of about 2 cm to 4 cm. Due to the elastic properties of the connecting part 32 with a high friction coefficient of its silicone material, this serves to fit tightly on the suction outlet 23. It should be safe against being pulled off. For an easier manual fixing, Fig. 3 shows two handling tabs 35a and 35b at the end of the small region 34 of the connecting part 32 with its small sleeve 37. These handling tabs 35a and 35b serve to manually grab them and pull the small sleeve 37 over the suction outlet 23.

[0030] The cross-section inside the connecting part 32 is gradually widening from the small region 34 on the one hand to a larger region 39 on the other end forming a large sleeve 40. This large sleeve 40 also has a rectangular cross-section with rounded corner regions.

[0031] The discharge part 41 being made of rigid plastic material such as thermoplastic material, preferably polyamide, with a thickness of around 1,5 mm, has a connection frame 42 towards the connecting part 32. This connection frame 42 fits into the large sleeve 40 of the connecting part 32 such that its cross-section is slightly larger for the large sleeve 40 to fit elastically but tightly over it and provide a firm connection. The large sleeve 40 could also be provided with handling tabs similar to the ones of the small sleeve 37. Ribs or the like on the outside of the connection frame 42 could be provided for a more secure fixing.

[0032] The discharge part 41 has a discharge flange 44 running around and neighboring directly to the connection frame 42. Its function will be described later. Pointing away from the suction device 20 in the final assembly state, the discharge part 41 is provided with a discharge cap 45 with specifically rounded form, having a discharge opening 46 pointing downwards in an oblique angle of between 10° and 25° to the vertical. This means that discharged air will leave the discharge part 41 and, as such, the outlet device 30 mainly in a direction downwards. To better guide an air flow in a direction as wanted, two air guide plates 47a and 47b are provided starting at the entry of air into the discharge part 41, and ending at the discharge opening 46. These air guide plates 47a and 47b may even protrude somewhat into the connecting part 32. They also serve to provide better mechanical

stability for the discharge part 41 and for the connection frame 42, in particular, as mentioned above.

[0033] As shown in the assembled state of Fig. 2, the outlet device 30 provides an air outlet of the suction device 20 which is located somewhat behind the suction device 20 and guides the air downwards. This serves to guide the air behind a piece of furniture underneath a worktop into which the cooking hob 11 is to be installed, as will be explained hereinafter.

[0034] According to Fig. 4, a worktop 51 is provided with an installation opening 52. The installation opening 52 has a size such that the hob housing 17a with the induction heating coils 16 in it as well as a hob housing 17b with further functional devices of the cooking hob 11 can fit well into this installation opening 52. The cross-section of the installation opening 52 is also way larger than the size of the suction device 20 as well as its suction outlet 23. Only the outlet device 30 is protruding more to the backside such that it even protrudes over or behind the rear edge of the hob plate 13. This serves for the end of the outlet device 30 with the discharge part 41 to fit into a wall opening 56 of a back wall 55 of a piece of furniture 54 mounted underneath the worktop 51, as can be taken from the final positions of Fig. 6 and 9. However, due to this protruding outlet device 30, the movement to install the pre-assembled cooking hob 11 according to Fig. 2 is, according to Figs. 4 to 6, a pivoting movement such that in a first step the cooking hob 11 is held in an oblique way with the rear edge of the hob plate 13 being much lower than a front edge. Then as a first part the outlet device 30 is introduced through the installation opening 52. Then, according to Fig. 5, a kind of pivoting or rotating movement, respectively, follows. This pivoting or rotating movement serves to insert the discharge cap 45 of the discharge part 41 into the wall opening 56 of the back wall 55. Even though this step, following any movement after the position of Fig. 4, is not visible for the mounting personnel, the introduction is easy because the rear edge of the hob plate 13 only needs to be placed at or close to the rear edge of the installation opening 52 in a mainly vertical movement. After this, the anti-clockwise pivoting or rotation of the cooking hob 11 will also and surely bring the discharge cap 45 into the wall opening 56. This of course cannot always be very exact, which will be described later on in connection with Figs. 7 and 8.

[0035] In a final step, also the front edge of the hob plate 13 is in its final position in the installation opening 52, as is shown in Fig. 6. The flexibility of the connecting part 32 of the outlet device 30 serves to make a kind of adaptation between the final position of the suction outlet 23 of the suction device 20 on the one hand, and the discharge part 41 of the outlet device 30 in the wall opening 56 on the other hand. This serves to compensate smaller mistakes in placing the wall opening 56 too high or too low or even if it is laterally displaced somewhat. It also serves to adapt potential tolerances to the location of the back wall 55, whether it can be closer to the suction device 20 than assumed.

[0036] Any further fixing of the discharge part 41 or the discharge cap 45, respectively, to the back wall 55 is not needed, as it should regularly be pressed by an elastic force of the connecting part 32 against the back wall 55. Alternatively, if it is within reach, for example from below, one or more screws through the discharge flange 44 and the back wall 55 may be provided, but they are only optional and not necessary.

[0037] Fig. 7 shows in a schematic view according to a step between Fig. 4 and Fig. 6 how the outlet device 30 with a schematically drawn connecting part 32 and the discharge part 41 affixed to the suction outlet 23 of the suction housing 21 is, at first, positioned before the wall opening 56 of the back wall 55. As can also be taken from Fig. 7, a bellows 38 may be provided shortly before an end of the connecting part 32. Such an optional bellows 38 has been explained in the beginning and can generally be provided at the connecting part 32 to provide an extra flexibility and ability to adapt the shape of the connecting part 32 and, in particular, the orientation and/or the position of the large sleeve 40. It can clearly be seen that the discharge cap 45 with the discharge flange 44 are in perfect alignment with the wall opening 56, such that, as shown in the right picture, it will perfectly fit. This is also assisted by the widely rounded shape of the discharge cap 45 on its upper end, which may at first come into contact with an upper rim of the wall opening 56 and serves for facilitating the introduction. A kind of elastic force is exerted onto the outlet device 30 in the final position according to the right picture, such that the bellows 38 will be compressed somewhat.

[0038] In the configuration of Fig. 8, the outlet device 30 is somewhat too low underneath the wall opening 56 to fit perfectly in it. This can be compensated by also introducing at first the discharge cap 45 and then abutting the discharge flange 44 to the back wall 55. In the final assembly step, the suction housing 21 with the suction outlet 23 will be slightly lower than the wall opening 56. This is then compensated by the elasticity of the connecting part 32 in overall, and in particular by the elastic bellows 38, which is somewhat bent upwards. Also in this case the elastic force of the elastic connecting part 32 will press the rigid discharge part 41 and, in particular, the discharge flange 44 against the back wall 55. It will perfectly compensate any intolerance for a perfect fit of the discharge part 41 to the back wall 55 to blow out used air of the suction device 20 behind the back wall 55 of the furniture 54.

[0039] From the sectional view in Fig. 9 it can be taken that the left small sleeve 37 of the connecting part 32 is mounted by overlapping the suction outlet 23 of the suction housing 21. The large sleeve 40 of the connecting part 32 overlaps the connection frame 42 of the rigid discharge part 41 in firm manner. This discharge part 41 again is pressed against the back wall 55 of the furniture 54 such that the discharge cap 45 and the discharge opening 46 are located behind the back wall 55. This guarantees that discharged air is always blown

behind the back wall 54.

[0040] In Fig. 10, a view onto a system 50 similar to the one of Fig. 9 is shown. The cooking hob 11, the worktop 51 and the furniture 54 with the back wall 55 of are exactly as the one of Fig. 9. The wall opening 56 in the back wall 55 is larger in the vertical direction than the one of Fig. 9, which reason is that it should be a standard opening always to be provided like this, irrespective of whether the worktop 51 is thick as in Fig. 10, or much thinner, for example made of stainless steel. To be able to close this larger opening irrespective of the thickness of the worktop 51, without the need for too much adaptation by the flexible connecting part 31, the stencil 60 may generally be inserted either with a thinner side 63a pointing upwards or with a thicker side 63b pointing upwards, see also Fig. 11. In the case of Fig. 10, the stencil 60 has been inserted with the thinner side 63a pointing upwards as the worktop 51 is rather thick, and the outlet device 30 with the discharge part 41 is rather high compared to the opening 56.

[0041] It can also be taken from Fig. 9 that the discharge flange 44 is directly abutted against the back wall 55 around the wall opening 56. In the upper part of the opening 56, the discharge flange 44 directly closes the wall opening 56, whereas in the lower part there would be a gap between the discharge flange 44 and the lower rim of the wall opening 56. To close this gap, the thicker side 63b is provided behind the flange 44, overlapping the rim around the wall opening 56 with some mm. The stencil 60 may be held between the large sleeve 40 of the flexible connecting part 31 and the discharge flange 44 of the discharge part 41. It is slid on the connection frame 42 in the needed orientation, which may be helped by providing information on the sides 63 such as arrows or the like, and when the large sleeve 40 is slid over the connection frame 42, it is fixed between them. The surface of the stencil 60 or its sides 63, respectively, can be provided with steps or depressions to accommodate any of the named parts.

Claims

1. Cooking hob, comprising:

- a hob plate,
- several heating devices on/under the hob plate,
- a suction opening in the hob plate, in particular within an outer edge of the hob plate and at a distance of at least 2 cm therefrom,
- a suction device under the hob plate, which suction device is connected to the suction opening in an air-guiding manner for suction of steam and of exhaust air from cooking processes on the hob plate downwards,

+ wherein the suction device comprises an

outlet device, which outlet device is connected in air-guiding manner to the suction device,

+ wherein the outlet device projects laterally and in a substantially horizontal direction below the plane of the hob plate from the suction device, **characterised in that**

- the outlet device is designed to be detachable from the suction device, preferably detachable without tools, in particular in plug-in manner,
- the outlet device has two parts, namely a connecting part for connection to the suction device, and a discharge part, the discharge part leading into the open or to let air out of the suction device, in particular into or behind a piece of kitchen furniture below a worktop in which the cooking hob is inserted,
- the connecting part is elastic and/or deformable,
- the discharge part is designed to be rigid and/or non-deformable.

2. Cooking hob according to claim 1, **characterised in that** the connecting part and the discharge part are manufactured separately as two parts, which two parts are connected to one another, in particular detachably connected to one another, preferably non-positively connected to one another.

3. Cooking hob according to claim 1 or 2, **characterised in that** the connecting part and the discharge part are firmly connected to one another by being plugged one into the other, the elastic and/or deformable connecting part preferably enclosing or engaging around the rigid and/or non-deformable discharge part at least in an encompassing manner, preferably enclosing or engaging around it in a sealed manner.

4. Cooking hob according to one of the preceding claims, **characterised in that** the connecting part consists of an elastomer with a hardness between 50 and 90 Shore A, preferably with a hardness between 60 and 75 Shore A, and/or that the discharge part consists of a thermoplastic material, preferably Polyamid.

5. Cooking hob according to one of the preceding claims, **characterised in that** the connecting part is connected to the suction device by fitting into one another and/or in a force-locking manner, the connecting part preferably being fastened to an outlet opening of the suction device by means of an elastic sleeve via a short tube extension or the like.

6. Cooking hob according to one of the preceding

- claims, **characterised in that** the suction device extends within the vertical projection of the cooking hob, preferably with the outlet device projecting laterally beyond the vertical projection of the cooking hob, in particular with at least a part of the discharge part.
7. Cooking hob according to claim 6, **characterised in that** the cooking hob has, on the underside of the hob plate, a hob housing which accommodates and encloses at least the heating devices which are arranged against an underside of the hob plate, the hob housing extending within the vertical projection of the hob plate at a distance of at least 1 cm from an outer edge of the hob plate, preferably between 1,5 cm and 4 cm away from the outer edge, wherein the suction device extends within the vertical projection of said hob housing, and wherein preferably the connecting part extends within the vertical projection of the hob housing and the discharge part projects laterally beyond said vertical projection of the hob housing.
8. Cooking hob according to one of the preceding claims, **characterised in that** the outlet device is situated above a plane forming an underside of the extraction device, wherein preferably the outlet device is situated below a plane forming an upper side of the extraction device or below an underside of a receiving housing of the cooking hob, a hob control and a power supply of the cooking hob being arranged in this receiving housing.
9. Cooking hob according to one of the preceding claims, **characterised in that** an air guide cross-section of the outlet device increases monotonically from the connection to the suction device to the discharge opening of the discharge part, wherein in particular the discharge part has a larger air guide cross-section at least in the transition to the connecting part than the connecting part in the transition to the suction device, preferably 20% to 150% larger, even more preferably 70% to 120% larger, even more preferably the air guide cross-section of the discharge opening being smaller than the air guide cross-section in the transition to the suction device.
10. Cooking hob according to one of the preceding claims, **characterised in that** the direction of the air in the outlet device is deflected or changed from substantially horizontal at an inlet from the suction device into the outlet device to obliquely downwards or vertically downwards at a discharge opening of the discharge part, wherein preferably the discharge opening has an air guide cross-section amounting to 20% to 50% of the air guide cross-section in the transition from the connecting part to the discharge part.
11. Cooking hob according to one of the preceding claims, **characterised in that** air guide plates are provided in the discharge part, which air guide plates run in the direction of the air flow and preferably extend as far as a discharge opening of the discharge part, wherein preferably two to four such air guide plates are provided, wherein in particular the air guide plates extend in vertical direction over an entire air guide cross-section of the discharge part.
12. Cooking hob according to one of the preceding claims, **characterised in that** the discharge part has, in particular in a region of the largest extension or the largest cross-section, at least one or more outwardly projecting projections defining a vertical plane or running in a vertical plane, in particular in the manner of a circumferential bearing rib on the outside of the discharge part.
13. A system comprising a cooking hob according to one of the preceding claims and a worktop having an installation opening therein, the installation opening being smaller than the cooking hob and being larger than a hob housing of the cooking hob and the suction device without the outlet device.
14. System according to claim 13, **characterised in that** a wall, in particular a vertical furniture wall, is arranged in a region below the hob plate or lower than the hob plate, the wall having an opening through which a part of the outlet device extends, in particular only a part of the discharge part with a discharge opening, in such a way that the discharge opening is largely on the other side of the wall than the suction device, preferably the discharge opening pointing at least partially downwards at an angle between 0° and 45° to the vertical.
15. System according to claim 13 or 14, **characterised in that** a stencil is provided around the opening in the wall, which stencil has a central opening corresponding to the outer cross-section of the discharge part, wherein the central opening is smaller than the opening in the wall, preferably with a smaller height but corresponding width, wherein in particular the stencil has a frame around the central opening and said frame has on one side a width amounting to 30% to 70%, preferably 40% to 60%, of a width on the opposing side.
16. A method of installing a cooking hob according to one of the claims 1 to 12 in a worktop,
 + wherein the completely pre-assembled cooking hob with the outlet device mounted to the suction device is brought from above to a suitable installation opening in the worktop, which

installation opening is smaller than the hob plate of the cooking hob,

+ wherein, in a subsequent step, the cooking hob is first inserted into the installation opening with an outer region, on which the outlet device protrudes laterally, inclined downwards with an initially vertical movement and then with a rotated or pivoted movement, in which movement the edge of the cooking hob opposite the outlet device is moved further downwards than the outlet device,

+ wherein in the pivoted movement at least one end of the outlet device or the discharge part is guided under an edge of the installation opening on the worktop and finally the cooking hob is fixed to or in the installation opening,

+ wherein in the end position of the cooking hob at least the outlet device extends vertically below an edge of the installation opening.

17. Method according to claim 16, **characterised in that** a vertical wall, in particular an underbuilt furniture wall, is provided under the worktop, a through opening corresponding to a vertical outer transverse sectional area of the outlet device or of the discharge part being provided in the vertical wall, wherein the outlet device or the discharge part is moved into this through opening in a pivoting manner when the cooking hob is installed in the worktop and protrudes through the through opening over the vertical wall, in particular protrudes at least to a large extent with a discharge opening on the discharge part.

5

10

15

20

25

30

35

40

45

50

55

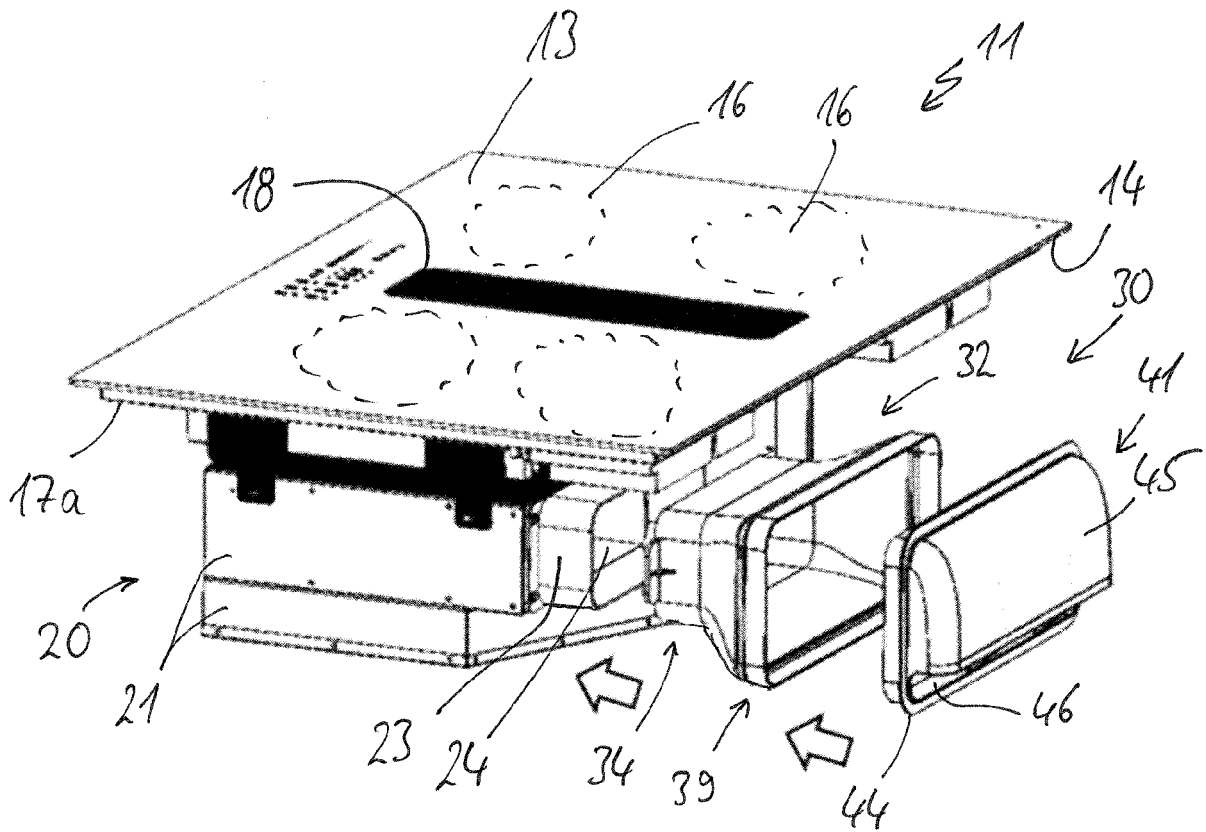

Fig. 1

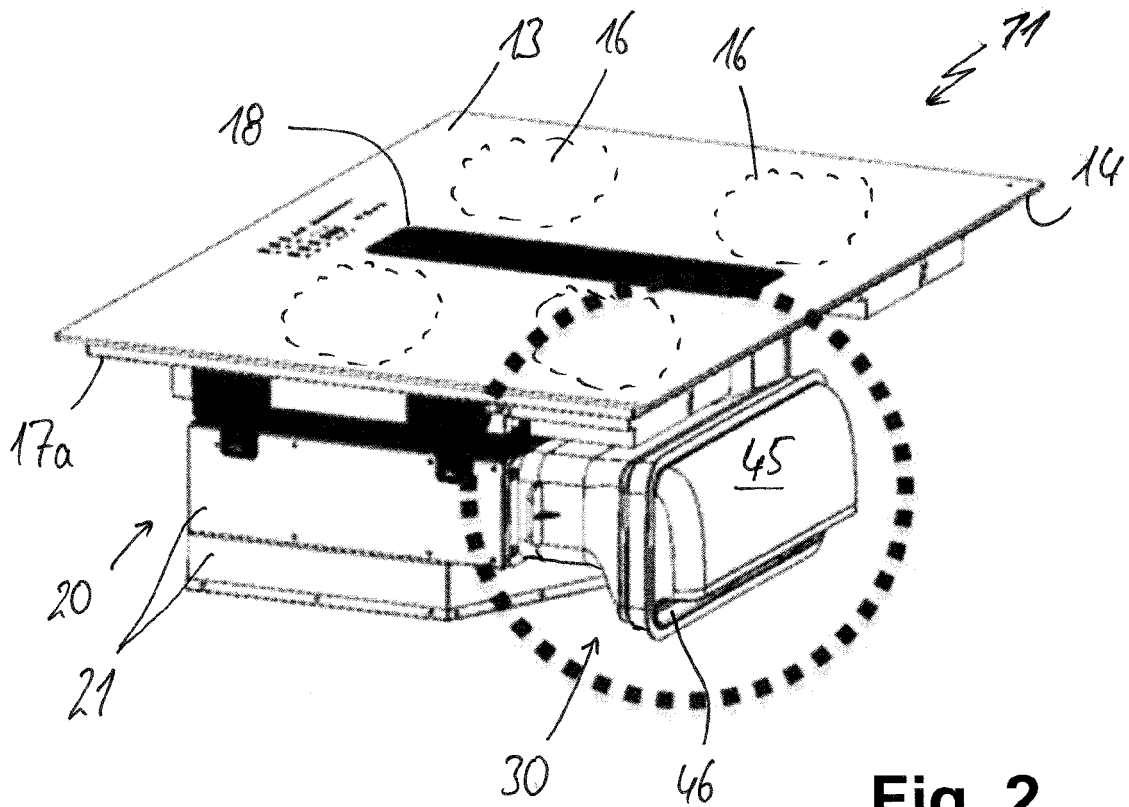

Fig. 2

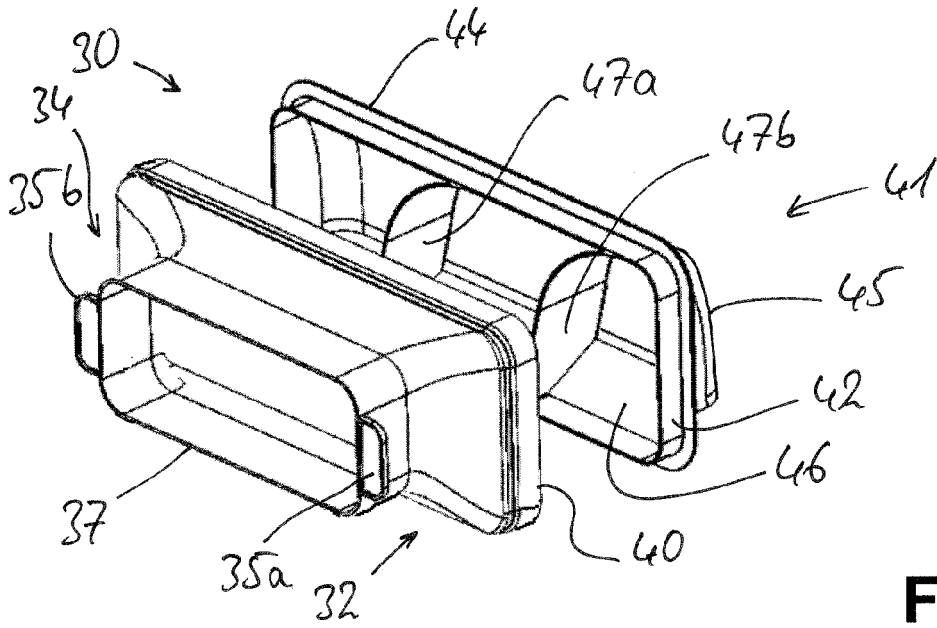

Fig. 3

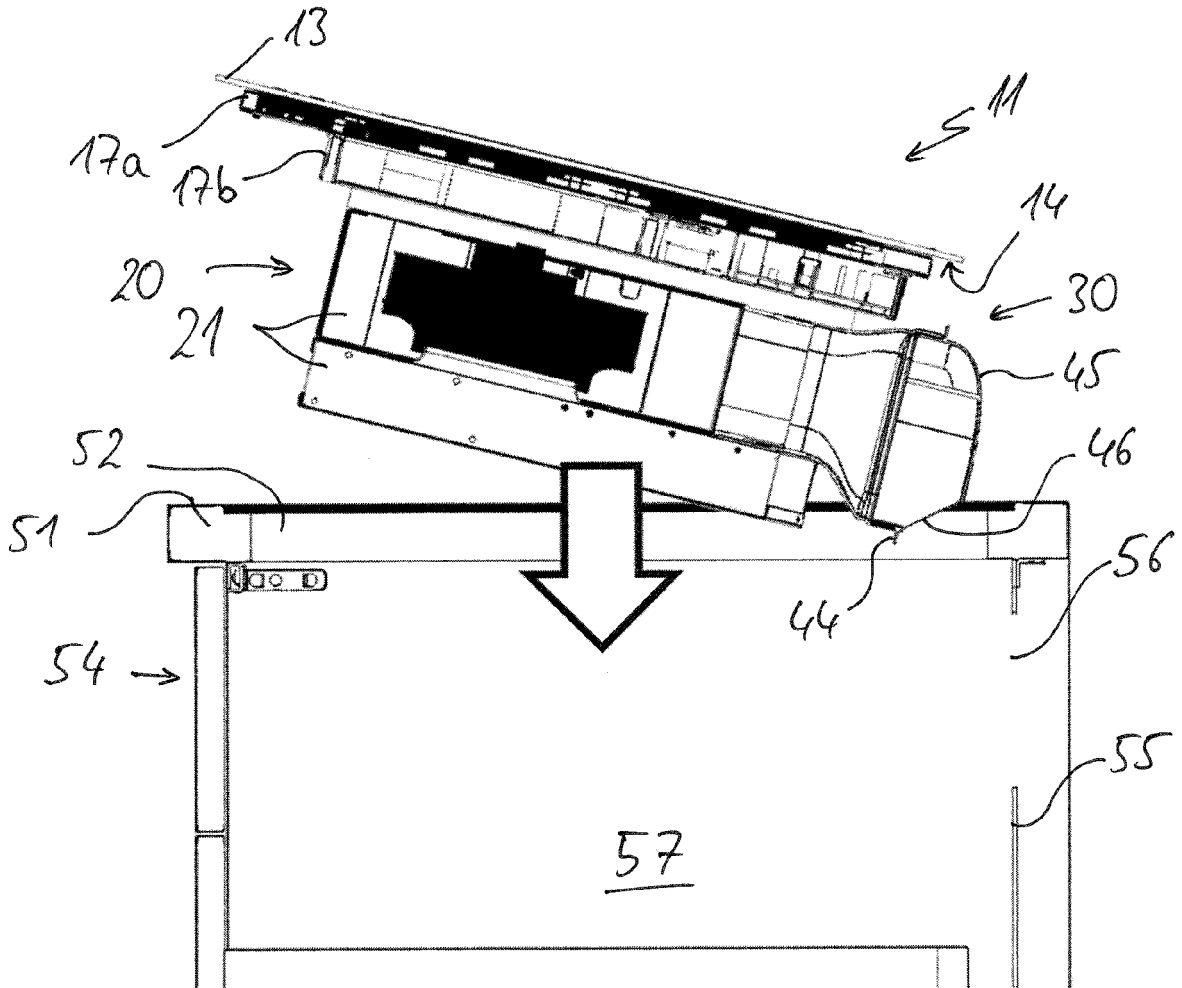

Fig. 4

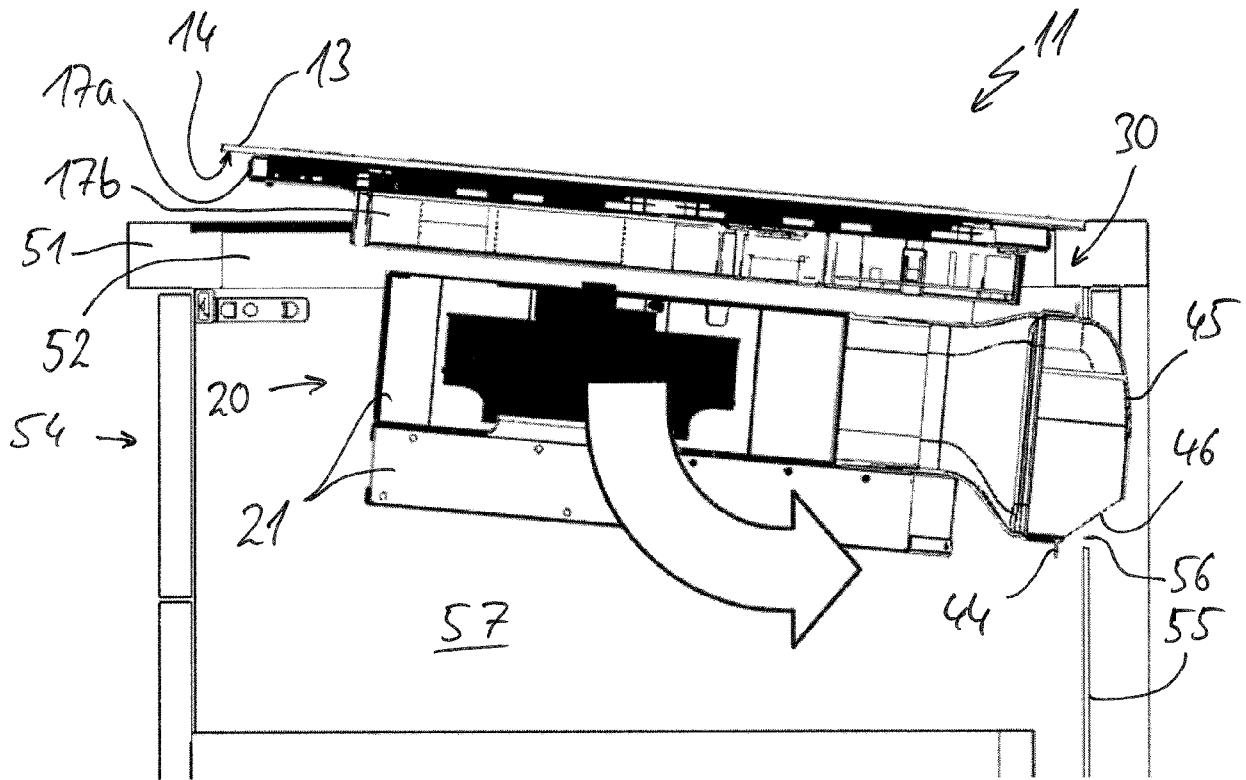

Fig. 5

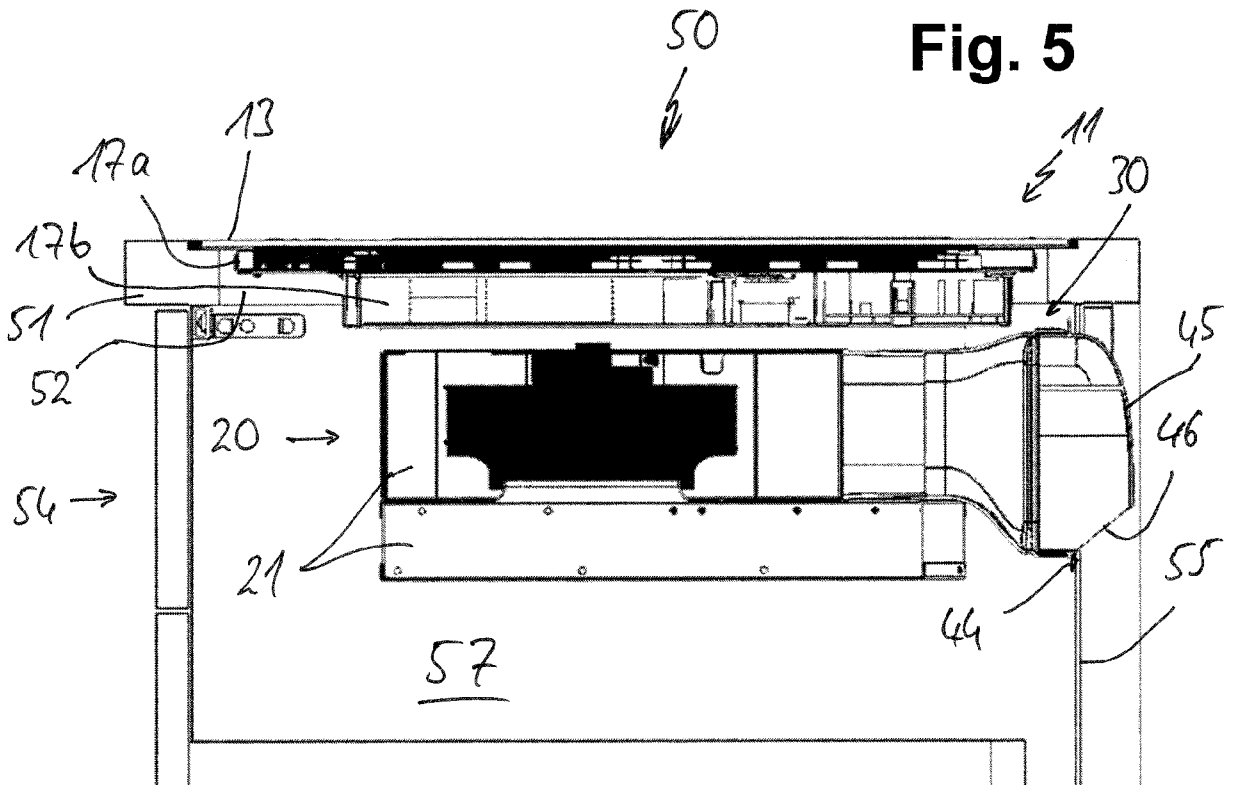

Fig. 6

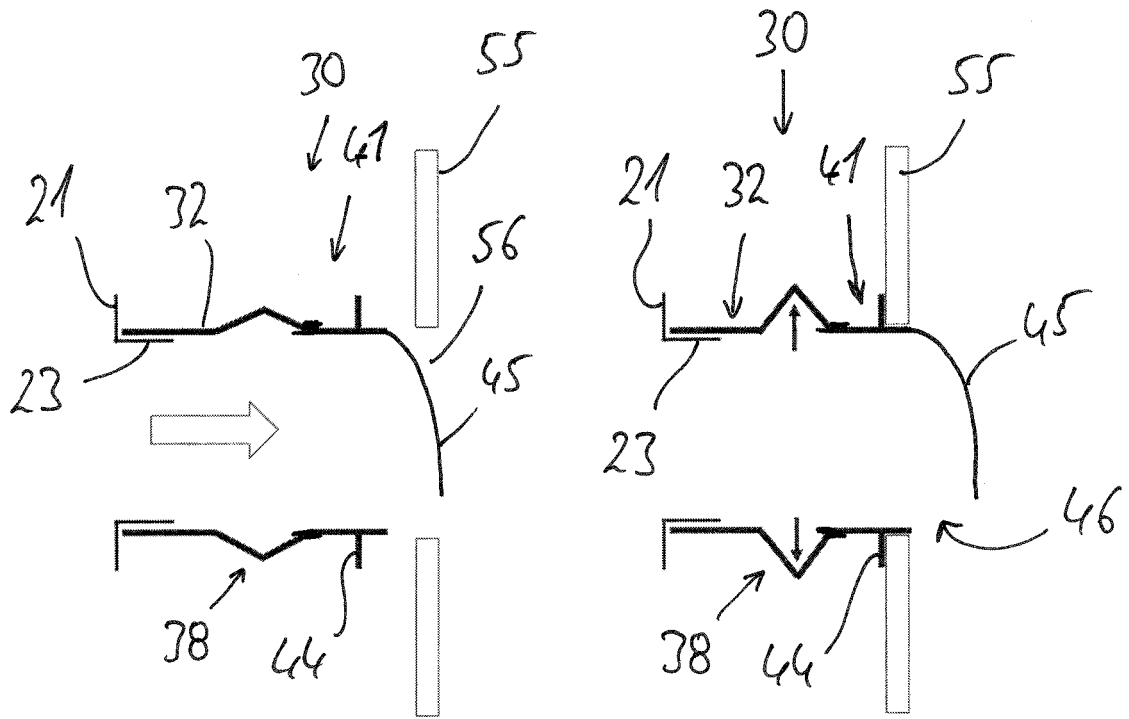

Fig. 7

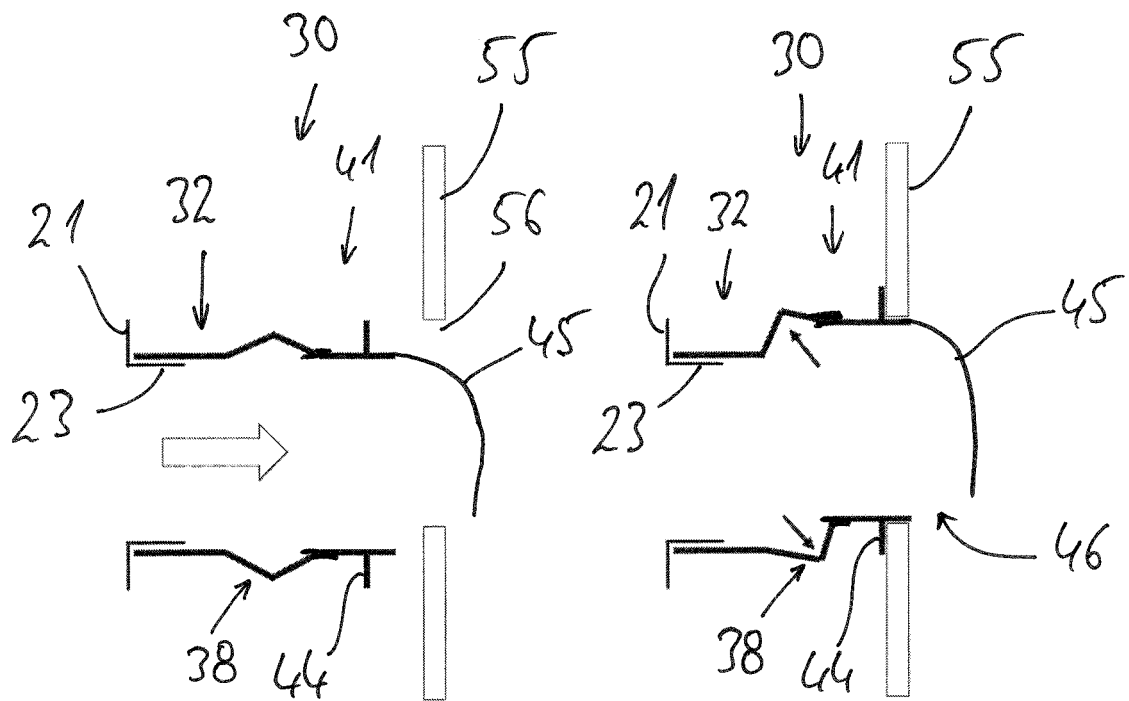

Fig. 8

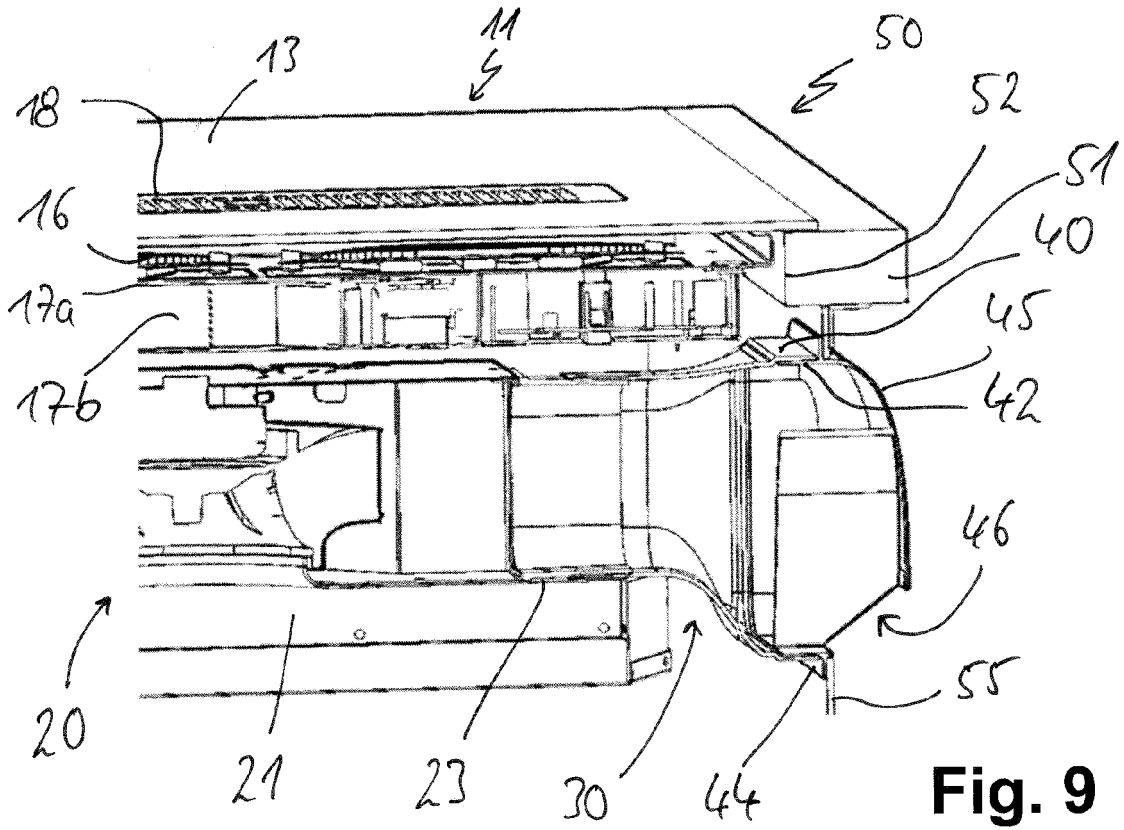

Fig. 9

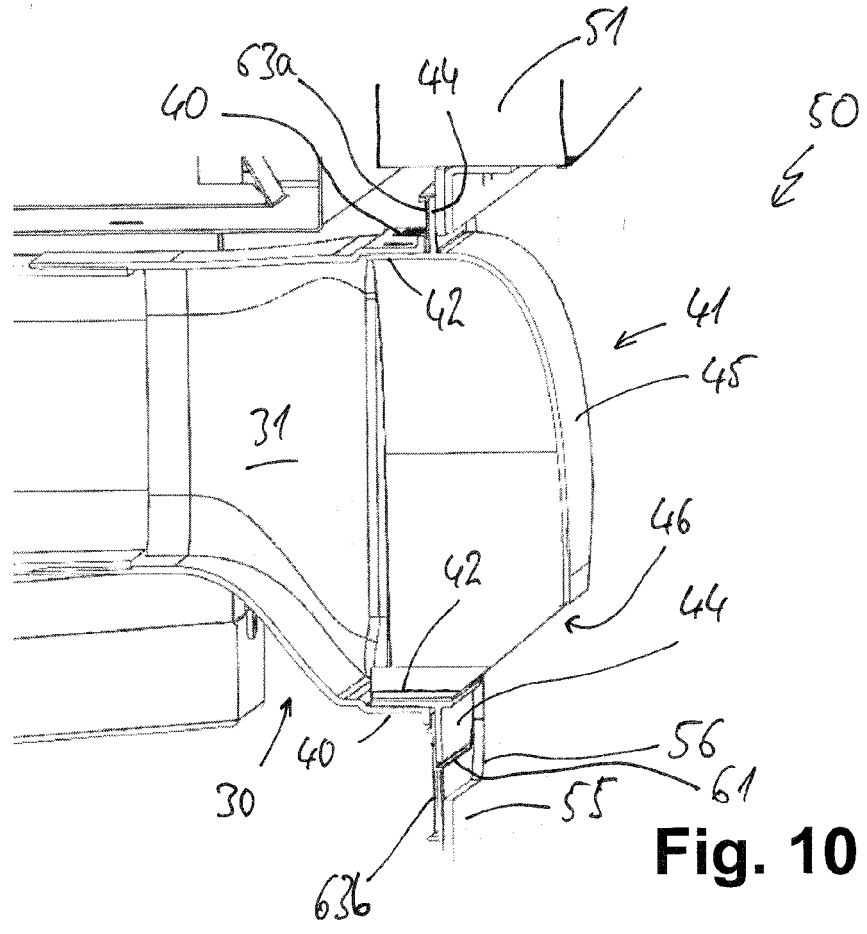

Fig. 10

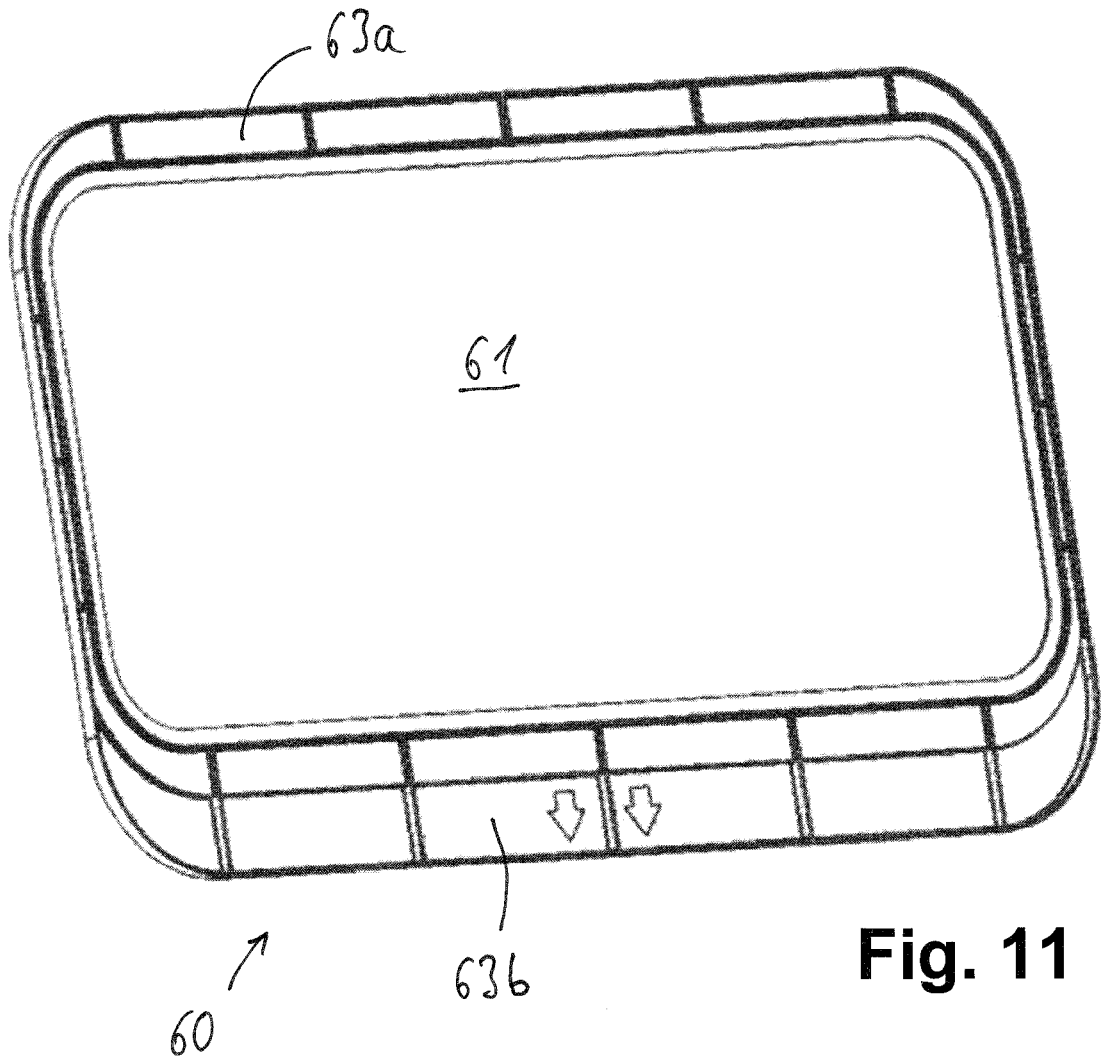

Fig. 11



EUROPEAN SEARCH REPORT

Application Number
EP 23 19 6227

5

10

15

20

25

30

35

40

45

50

55

DOCUMENTS CONSIDERED TO BE RELEVANT			
Category	Citation of document with indication, where appropriate, of relevant passages	Relevant to claim	CLASSIFICATION OF THE APPLICATION (IPC)
Y	DE 10 2020 202599 A1 (BRUCKBAUER WILHELM [DE]) 2 September 2021 (2021-09-02) * paragraphs [0086], [0070], [0071], [0096]; figures 1, 2, 3, 5 *	1-17	INV. F24C15/20
Y	EP 3 789 678 A1 (BSH HAUSGERAETE GMBH [DE]) 10 March 2021 (2021-03-10) * paragraphs [0001], [0002], [0013], [0014], [0049], [0058]; figures 1, 6, 8, 12 *	1-17	
Y	FR 2 504 372 A1 (JENN AIR CORP [US]) 29 October 1982 (1982-10-29) * figure 1 * * page 4, line 14 - page 4, line 20 *	10	
Y	US 3 334 621 A (BRITT RONALD L) 8 August 1967 (1967-08-08) * figure 3 *	11	
Y	DE 10 2021 101735 B4 (MIELE & CIE [DE]) 15 September 2022 (2022-09-15) * paragraph [0001]; claim 16 *	16, 17	
			TECHNICAL FIELDS SEARCHED (IPC)
			F24C
The present search report has been drawn up for all claims			
Place of search The Hague		Date of completion of the search 26 January 2024	Examiner Jalal, Rashwan
CATEGORY OF CITED DOCUMENTS X : particularly relevant if taken alone Y : particularly relevant if combined with another document of the same category A : technological background O : non-written disclosure P : intermediate document		T : theory or principle underlying the invention E : earlier patent document, but published on, or after the filing date D : document cited in the application L : document cited for other reasons & : member of the same patent family, corresponding document	

1
EPO FORM 1503 03.82 (P04C01)

ANNEX TO THE EUROPEAN SEARCH REPORT
ON EUROPEAN PATENT APPLICATION NO.

EP 23 19 6227

5

This annex lists the patent family members relating to the patent documents cited in the above-mentioned European search report. The members are as contained in the European Patent Office EDP file on
The European Patent Office is in no way liable for these particulars which are merely given for the purpose of information.

26-01-2024

10

Patent document cited in search report	Publication date	Patent family member(s)	Publication date
DE 102020202599 A1	02-09-2021	NONE	

EP 3789678 A1	10-03-2021	NONE	

FR 2504372 A1	29-10-1982	AU 546959 B2	26-09-1985
		CA 1168121 A	29-05-1984
		DE 3214926 A1	25-11-1982
		FR 2504372 A1	29-10-1982
		GB 2097526 A	03-11-1982
		JP S57182030 A	09-11-1982
		US 4411254 A	25-10-1983
		ZA 822055 B	30-11-1983

US 3334621 A	08-08-1967	NONE	

DE 102021101735 B4	15-09-2022	DE 102021101735 A1	28-07-2022
		EP 4036480 A2	03-08-2022

15

20

25

30

35

40

45

50

55

EPO FORM P0459

For more details about this annex : see Official Journal of the European Patent Office, No. 12/82

REFERENCES CITED IN THE DESCRIPTION

This list of references cited by the applicant is for the reader's convenience only. It does not form part of the European patent document. Even though great care has been taken in compiling the references, errors or omissions cannot be excluded and the EPO disclaims all liability in this regard.

Patent documents cited in the description

- EP 3869107 B1 [0002]