



(11) **EP 4 530 385 A1**

(12) **EUROPEAN PATENT APPLICATION**
published in accordance with Art. 153(4) EPC

(43) Date of publication:
02.04.2025 Bulletin 2025/14

(21) Application number: **23824247.3**

(22) Date of filing: **15.06.2023**

(51) International Patent Classification (IPC):
D06F 31/00 ^(2006.01) **D06F 39/12** ^(2006.01)
D06F 39/00 ^(2024.01) **D06F 37/30** ^(2020.01)
D06F 37/26 ^(2006.01) **D06F 39/02** ^(2006.01)

(52) Cooperative Patent Classification (CPC):
D06F 31/00; D06F 37/26; D06F 37/30; D06F 39/00;
D06F 39/02; D06F 39/12

(86) International application number:
PCT/KR2023/008290

(87) International publication number:
WO 2023/244034 (21.12.2023 Gazette 2023/51)

(84) Designated Contracting States:
AL AT BE BG CH CY CZ DE DK EE ES FI FR GB
GR HR HU IE IS IT LI LT LU LV MC ME MK MT NL
NO PL PT RO RS SE SI SK SM TR

Designated Extension States:
BA

Designated Validation States:
KH MA MD TN

(30) Priority: **16.06.2022 KR 20220073422**

(71) Applicant: **LG Electronics Inc.**
Yeongdeungpo-gu
Seoul 07336 (KR)

(72) Inventors:
• **NAM, Hyunsu**
Seoul 08592 (KR)
• **LEE, Junseok**
Seoul 08592 (KR)

(74) Representative: **Ter Meer Steinmeister & Partner**
Patentanwälte mbB
Nymphenburger Straße 4
80335 München (DE)

(54) **LAUNDRY TREATING APPARATUS**

(57) Disclosed is a laundry treating apparatus, and the laundry treating apparatus according to an embodiment of the present invention comprises a first treating apparatus and a second treating apparatus. A first cabinet comprises a top panel defining the upper surface of the first treating apparatus and supporting a second cabinet, and the second cabinet comprises a leg portion protruding toward the top panel and supported by the top panel. The top panel comprises a leg seating portion which is recessed to be away from the second cabinet and in which the leg portion is seated and supported, and the leg portion has formed therein a space that is opened toward the leg seating portion.

FIG. 11

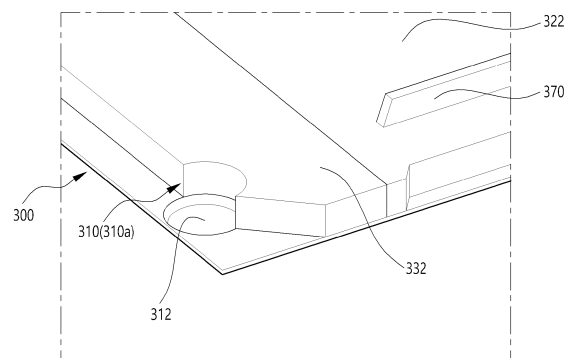

EP 4 530 385 A1

Description

[Technical Field]

[0001] The present disclosure relates to a laundry treating apparatus, and more specifically, to a laundry treating apparatus including a first treating apparatus at a lower side and a second treating apparatus at an upper side.

[Background]

[0002] A laundry treating apparatus is an apparatus that performs necessary treatment on laundry, such as removal of contaminants on the laundry or drying, by putting the laundry such as clothing or bedding into a drum.

[0003] When the laundry treating apparatus is designed to remove the contaminants from the laundry, the laundry treating apparatus may perform processes such as washing, rinsing, dehydration, and drying, and the laundry treating apparatus may be categorized into a top loading type and a front loading type based on a scheme of putting the laundry into the drum.

[0004] The laundry treating apparatus may include a cabinet forming an outer appearance, a tub accommodated inside the cabinet, the drum rotatably mounted inside the tub and into which the laundry is put, and a detergent supply apparatus that supplies detergent into the drum.

[0005] When the drum rotates by a motor while washing water is supplied to the laundry accommodated in the drum, dirt on the laundry may be removed by friction between the drum and washing water.

[0006] The detergent supply apparatus has a detergent supply function to enhance a washing effect. In this regard, the detergent refers to a substance that enhances the washing effect, such as a fabric detergent, a fabric softener, and a fabric bleach. As the detergent, a powder-type detergent or a liquid-type detergent may be used.

[0007] In one example, when the laundry treating apparatus is designed to dry the laundry, the laundry treating apparatus may provide dry air to the laundry to remove moisture from the laundry.

[0008] The laundry treating apparatus may include the cabinet, the drum that is rotatably disposed inside the cabinet, a heating means that heats or dries air provided to the laundry, and the like.

[0009] By supplying dry air to the laundry accommodated in the drum, moisture present in the laundry may be evaporated and removed by the dry air, and water from the laundry may be removed.

[0010] In one example, related document KR 10-2008-0021921 A1 illustrates a laundry treating apparatus equipped with a plurality of treating apparatuses. The laundry treating apparatus has a first treating apparatus at a lower side and a second treating apparatus at

an upper side.

[0011] In the laundry treating apparatus, the first treating apparatus and the second treating apparatus may have great loads, and during a manufacturing process or an installation process in a use space, the second treating apparatus may be seated on top of the first treating apparatus and supported by the first treating apparatus.

[0012] However, in the laundry treating apparatus, the second treating apparatus has a support structure that may be used only when it is stacked on the first treating apparatus, and does not have a support structure for being used independently while positioned on the ground.

[0013] However, the second treating apparatus is not necessarily used while being stacked on the first treating apparatus, and therefore, a structure that may be operated independently while the second treating apparatus is placed on the ground needs to be considered.

[0014] In relation thereto, the second treating apparatus may include a leg for supporting a load. It is important that the leg is able to effectively support the second treating apparatus in both of the state of being directly positioned on the ground and the state of being seated on the first treating apparatus.

[0015] In addition, designing separate support structures for the cases in which the second treating apparatus is positioned on the ground and is stacked on the first treating apparatus may significantly reduce efficiency of a product manufacturing process, and there may be a problem that the support structure applied to one case is difficult to be applied to the other case.

[0016] Accordingly, it is an important task in the present technical field to develop a laundry treating apparatus that may be applied with a manufacturing process, which may be effectively applied to both of the cases in which the second treating apparatus is directly disposed on the ground and has the stacked structure with the first treating apparatus, and furthermore, may be effectively converted for various arrangement environments as described above and be efficient.

[Summary]

[Technical Problem]

[0017] Embodiments of the present disclosure are to provide a laundry treating apparatus that may provide convenience of laundry treatment to a user via a plurality of treating apparatuses.

[0018] In addition, the embodiments of the present disclosure are to provide a laundry treating apparatus in which a plurality of treating apparatuses may have a stable stacked structure.

[0019] In addition, embodiments of the present disclosure are to provide a laundry treating apparatus having a support structure that may be effectively applied even when a second treating apparatus seated on a first treating apparatus is independently utilized.

[0020] In addition, the embodiments of the present disclosure are to provide a laundry treating apparatus that may include each of a plurality of treating apparatuses having a support structure that may be effectively applied to various arrangement environments, and may be applied with an efficient manufacturing process.

[0021] In addition, the embodiments of the present disclosure are to provide a laundry treating apparatus in which an internal space of each of a plurality of treating apparatuses may be effectively expanded and a stacked structure of the plurality of treating apparatuses may be stably implemented.

[Technical Solutions]

[0022] In a laundry treating apparatus according to an embodiment of the present disclosure, a second treating apparatus includes a leg to be supported by a first treating apparatus. The leg includes a space that is open toward the first treating apparatus.

[0023] The leg may have a structure that is advantageous for being seated on and supported by the first treating apparatus itself, and further, the leg may be coupled with an additional leg that may reinforce rigidity and effectively improve a support area size, to be directly supported on the ground.

[0024] The additional leg may be partially inserted into the open space of the leg and coupled with the leg, and a portion thereof exposed downward may have a greater area size than the leg, thereby increasing the support area size.

[0025] The first treating apparatus may have a top panel disposed on one surface facing the second treating apparatus, and a leg seating portion into which the leg of the second treating apparatus is inserted and seated may be defined in the top panel, so that the second treating apparatus may be stably seated and supported.

[0026] The top panel may be formed with a plurality of surfaces having different vertical levels so as to expand an internal space of the first cabinet or to stably seat the base of the second cabinet, and the leg seating portion may be defined in the top panel in a state where structural interference is minimized even when the plurality of surfaces are formed as described above.

[0027] In addition, the leg seating portion may be defined on a boundary between a first surface and a second surface having different vertical levels among the plurality of surfaces, when necessary, thereby being effectively defined at a location corresponding to the leg while minimizing interference with formation of the first surface and the second surface.

[0028] Such a laundry treating apparatus according to an embodiment of the present disclosure includes: a first treating apparatus including a first cabinet and a first drum disposed inside the first cabinet to accommodate laundry therein; and

a second treating apparatus including a second cabinet disposed on top of the first cabinet, and a second drum

disposed inside the second cabinet to accommodate the laundry therein,

[0029] The first cabinet includes a top panel defining a top surface of the first treating apparatus and supporting the second cabinet, and the second cabinet includes a leg protruding toward the top panel and supported by the top panel.

[0030] The top panel includes a leg seating portion recessed away from the second cabinet, wherein the leg is seated and supported in the leg seating portion, and a space open toward the leg seating portion is defined inside the leg.

[0031] The leg may be formed in a shape of a hollow column. The leg may be combinable with an additional leg that may be inserted into the space inside the leg.

[0032] The second cabinet may include a base defining a bottom surface of the second treating apparatus, and the leg may extend downward from the base.

[0033] The base may include a leg reinforcing rib extending along a radial direction of the leg away from the leg.

[0034] The top panel may include a plurality of surfaces parallel to ground, but having different vertical levels. The top panel may include a first surface and a second surface having a vertical level different from a vertical level of the first surface, and the leg seating portion may include a plurality of leg seating portions, and at least one of the plurality of leg seating portions may be positioned on a boundary between the first surface and the second surface.

[0035] The leg seating portions may include a leg seating surface supporting a lower end of the leg and having a vertical level lower than the vertical levels of the first surface and the second surface.

[0036] The vertical level of the second surface may be higher than the vertical level of the first surface, and the first treating apparatus may include an internal component disposed inside the first cabinet and having at least a portion positioned below the second surface.

[0037] The first treating apparatus may include a driver that rotates the first drum, and the internal component may correspond to at least a portion of a first controller that controls the driver and performs a laundry treatment course.

[0038] The top panel may include a grounding portion recessed downward and connected with a grounding line.

[0039] The grounding portion may extend along an edge of the top panel and may be open outward of the top panel along a direction parallel to ground, the grounding portion may include a grounding surface coupled with the grounding line, and a grounding side surface extending along an edge of the grounding surface, and at least a portion of the grounding side surface may extend at an angle with respect to an extension direction of the grounding portion.

[0040] The top panel may include a guide surface facing the second cabinet, and a first guide rib protruding

toward the second cabinet and extending along a first direction to suppress movement of the second cabinet may be disposed on the guide surface.

[0041] The first treating apparatus may include a first controller that is disposed inside the first cabinet and performs a laundry treatment course by controlling a driver that rotates the first drum.

[0042] The top panel may further include a control surface positioned higher than the guide surface and having at least a portion of the first controller disposed below.

[0043] The first treating apparatus may include a tub that is disposed inside the first cabinet, has the first drum disposed therein, and accommodates water therein, and a detergent supply that is disposed inside the first cabinet, stores detergent therein, and supplies the detergent into the tub.

[0044] The top panel may include a detergent supply surface positioned higher than the guide surface and having at least a portion of the detergent supply disposed below.

[0045] The first cabinet may include a front panel defining a front surface of the first treating apparatus, the detergent supply surface may be spaced rearwardly apart from the front panel, and the leg seating portion may include a plurality of leg seating portions, and at least one of the plurality of leg seating portions may be positioned between the detergent supply surface and the front panel.

[0046] The first cabinet may include a rear panel defining a rear surface of the first treating apparatus and a first side panel defining a first side surface of the first treating apparatus, and the leg seating portion may include a plurality of leg seating portions, and one of the plurality of leg seating portions may have the rear panel positioned at the rear thereof, have the first side panel on a first side thereof, and have the detergent supply surface positioned in front thereof and on a second side thereof.

[0047] The top panel may include a recessed surface positioned lower than the guide surface relative to ground, the second cabinet may include a base defining a bottom surface of the second treating apparatus, and the base may include a protruding surface facing the recessed surface and protruding toward the recessed surface.

[0048] The second treating apparatus may include a fluid circulator that is disposed on the protruding surface within the second cabinet and supplies or receives heat to or from air while fluid circulates.

[0049] The recessed surface may include a first recessed surface positioned lower than the guide surface and a second recessed surface positioned lower than the first recessed surface. The leg seating portion may include a plurality of leg seating portions, and at least one of the plurality of leg seating portions may be positioned on the first recessed surface.

[0050] The protruding surface may include a first protruding surface positioned on the first recessed surface,

and a second protruding surface positioned on the second recessed surface and protruding further than the first recessed surface.

[0051] The fluid circulator may include a compressor that compresses the fluid, and a cooling fan that cools the compressor, and the compressor may be positioned on the first protruding surface, and the cooling fan may be positioned on the second protruding surface.

[Advantageous Effects]

[0052] The embodiments of the present disclosure may provide the laundry treating apparatus that may provide the convenience of the laundry treatment to the user via the plurality of treating apparatuses.

[0053] In addition, the embodiments of the present disclosure may provide the laundry treating apparatus in which the plurality of treating apparatuses may have the stable stacked structure.

[0054] In addition, the embodiments of the present disclosure may provide the laundry treating apparatus having the support structure that may be effectively applied even when the second treating apparatus seated on the first treating apparatus is independently utilized.

[0055] In addition, the embodiments of the present disclosure may provide the laundry treating apparatus that may include each of the plurality of treating apparatuses having the support structure that may be effectively applied to the various arrangement environments, and may be applied with the efficient manufacturing process.

[0056] In addition, the embodiments of the present disclosure may provide the laundry treating apparatus in which the internal space of each of the plurality of treating apparatuses may be effectively expanded and the stacked structure of the plurality of treating apparatuses may be stably implemented.

[Brief Description of the Drawings]

[0057]

FIG. 1 is a front perspective view showing a laundry treating apparatus according to an embodiment of the present disclosure.

FIG. 2 is a side view showing a laundry treating apparatus according to an embodiment of the present disclosure.

FIG. 3 is a rear perspective view showing a laundry treating apparatus according to an embodiment of the present disclosure.

FIG. 4 is a view showing a first treating apparatus and a second treating apparatus separated from each other in a laundry treating apparatus according to an embodiment of the present disclosure.

FIG. 5 is a top perspective view of a top panel of a first cabinet in a laundry treating apparatus according to an embodiment of the present disclosure.

FIG. 6 is a bottom perspective view of a top panel of a

first cabinet in a laundry treating apparatus according to an embodiment of the present disclosure.

FIG. 7 is a bottom perspective view of a base of a second cabinet in a laundry treating apparatus according to an embodiment of the present disclosure.

FIG. 8 is a top view showing a top panel of a first cabinet in a laundry treating apparatus according to an embodiment of the present disclosure.

FIG. 9 is a bottom view showing a base of a second cabinet in a laundry treating apparatus according to an embodiment of the present disclosure.

FIG. 10 is a view showing a leg disposed on a base of a second cabinet in an embodiment of the present disclosure.

FIG. 11 is a view showing a leg seating portion defined in a top panel of a first cabinet in an embodiment of the present disclosure.

FIG. 12 is a side cross-sectional view of a base of a second cabinet seated on a top panel of a first cabinet in an embodiment of the present disclosure.

FIG. 13 is a view showing a grounding portion disposed on a top panel of a first cabinet in an embodiment of the present disclosure.

FIG. 14 is a view showing a first guide rib disposed on a top panel of a first cabinet in an embodiment of the present disclosure.

FIG. 15 is a view showing a second guide rib disposed on a base of a second cabinet in an embodiment of the present disclosure.

FIG. 16 is a cross-sectional view showing a first guide rib and a second guide rib in an embodiment of the present disclosure.

FIG. 17 is a view showing a front panel and a rear bracket of a first cabinet in an embodiment of the present disclosure.

FIG. 18 is a view showing a raised portion disposed on a top panel of a first cabinet in an embodiment of the present disclosure.

FIG. 19 is a view showing an accommodation space defined in a base of a second cabinet in an embodiment of the present disclosure.

FIG. 20 is a view showing a detergent supply located below a raised portion in an embodiment of the present disclosure.

FIG. 21 is an exploded perspective view showing a detergent supply in a laundry treating apparatus according to an embodiment of the present disclosure.

FIG. 22 is a cross-sectional view cut along a line A-A in FIG. 18.

FIG. 23 is a cross-sectional view cut along a line B-B in FIG. 18.

FIG. 24 is a view showing a recessed surface defined in a top panel of a first cabinet in an embodiment of the present disclosure.

FIG. 25 is a view showing a protruding surface disposed on a base of a second cabinet in an embodiment of the present disclosure.

FIG. 26 is a view showing a fluid circulator disposed on a base of a second cabinet in an embodiment of the present disclosure.

5 [Best Mode]

[0058] Hereinafter, with reference to the attached drawings, an embodiment of the present disclosure will be described in detail so as to be easily practiced by a person with ordinary skill in the art to which the present disclosure belongs.

[0059] However, the present disclosure may be implemented in various different forms and may not be limited to the embodiment described herein. In addition, to clearly illustrate the present disclosure in the drawings, parts that are not related to the description are omitted, and similar parts are given similar reference numerals throughout the present document.

[0060] In the present document, redundant descriptions of the same components are omitted.

[0061] Further, in the present document, it will be understood that when an element is referred to as being "connected with" another element, the element may be directly connected with the other element or intervening elements may also be present. In contrast, in the present document, it will be understood that when an element is referred to as being "directly connected with" another element, there are no intervening elements present.

[0062] Further, terms used herein are only used to describe a specific embodiment, and are not used as a limitation of the present disclosure.

[0063] Further, in the present document, a singular representation may include a plural representation unless it represents a definitely different meaning from the context.

[0064] Further, the terms such as "include" or "have" used herein are intended to indicate that features, numbers, steps, operations, elements, components, or combinations thereof used in the following description exist and it should be thus understood that the possibility of existence or addition of one or more different features, numbers, steps, operations, elements, components, or combinations thereof is not excluded.

[0065] Further, in the present document, the term 'and/or' includes a combination of a plurality of listed items or any of the plurality of listed items. Herein, 'A or B' may include 'A', 'B', or 'both A and B'.

[0066] FIG. 1 is a front perspective view of a laundry treating apparatus 1 according to an embodiment of the present disclosure. The laundry treating apparatus 1 according to an embodiment of the present disclosure includes a first treating apparatus 100 and a second treating apparatus 200.

[0067] The first treating apparatus 100 and the second treating apparatus 200 are apparatuses for treating laundry and are operable independently of each other. The first treating apparatus 100 and the second treating apparatus 200 may also be operated in associated with

each other.

[0068] In the present disclosure, the treatment of the laundry may be various processes such as washing, drying, and care of the laundry. Each of the first treating apparatus 100 and the second treating apparatus 200 may correspond to a dryer, a washing machine, a dryer/washer, as needed.

[0069] The first treating apparatus 100 may include a first cabinet 110 and a first drum 120 disposed inside the first cabinet 110 to accommodate the laundry therein. The first cabinet 110 may form an outer appearance of the first treating apparatus 100 and may define a space in which various components are disposed therein.

[0070] The first cabinet 110 may be formed by coupling a plurality of panels or the like to each other. The first cabinet 110 may include a front panel 112 disposed at a front side to form a front surface, a rear panel 119 disposed at a rear side to form a rear surface, a side panel 115 disposed at a side to form a side surface, a top panel 300 disposed at an upper side to form a top surface, and a base 400 or a bottom panel disposed at a lower side to form a bottom surface.

[0071] A laundry inlet to allow the laundry to be introduced into the first cabinet 110 may be defined in the front panel 112. The front panel 112 may have a first laundry door 102 that is pivotable, so that the laundry inlet may be opened and closed.

[0072] The first drum 120 may be disposed inside the first cabinet 110. The first drum 120 may be rotatable by a driver 130, and may include a drum inlet facing the laundry inlet. The laundry introduced via the laundry inlet may pass through the drum inlet and be accommodated inside the first drum 120.

[0073] When the first treating apparatus 100 is designed to wash the laundry, the first treating apparatus 100 may include a tub 125 disposed inside the first cabinet 110 to accommodate water therein, the first drum 120 may be installed to be rotatable inside the tub 125, and a detergent supply 150 for supplying detergent for the washing of the laundry into the tub 125 may be further included.

[0074] When the first treating apparatus 100 is designed to dry the laundry, the first treating apparatus 100 may include an air heater for providing dried and heated air into the first drum 120.

[0075] In one example, the second treating apparatus 200 may include a second cabinet 210 disposed on top of the first cabinet 110, and a second drum 220 disposed inside the second cabinet 210 to accommodate the laundry therein. Specific features of the second cabinet 210, a second laundry door 202, the second drum 220, and the like are the same as those of the first cabinet 110, the first laundry door 102, and the first drum 120 described above.

[0076] In the laundry treating apparatus 1 according to an embodiment of the present disclosure, the second treating apparatus 200 may be disposed on top of the first treating apparatus 100. That is, the first treating apparatus

100 and the second treating apparatus 200 may have a stack structure.

[0077] For example, the second cabinet 210 of the second treating apparatus 200 may be disposed on the first cabinet 110 of the first treating apparatus 100 and supported by the first cabinet 110. An embodiment of the present disclosure may include a control panel for adjusting operation of the first treating apparatus 100 and the second treating apparatus 200.

[0078] The control panel may be equipped separately for each of the first treating apparatus 100 and the second treating apparatus 200, or may be formed as a single unit on either the first cabinet 110 or the second cabinet 210 as shown in FIG. 1 so as to enable the operation control of each of the first treating apparatus 100 and the second treating apparatus 200.

[0079] FIG. 2 shows a side view of the laundry treating apparatus 1 according to an embodiment of the present disclosure. In an embodiment of the present disclosure, the second cabinet 210 may be stably fixed on the first cabinet 110.

[0080] FIG. 2 shows the laundry treating apparatus 1 according to an embodiment of the present disclosure in which the first treating apparatus 100 is designed to wash the laundry and includes the tub 125, and the second treating apparatus 200 is disposed on top of the first treating apparatus 100 and includes the second drum 220 for treating the laundry.

[0081] The first treating apparatus 100 may include a first controller 140 for receiving a command from the control panel or the like and adjusting rotation characteristics of the first drum 120, and the second treating apparatus 200 may include a second controller 240 for receiving a command from the control panel or the like and adjusting rotation characteristics of the second drum 220.

[0082] The first controller 140 and the second controller 240 may include a plurality of first controllers and a plurality of second controllers as needed. In addition, an integrated controller in which the first controller 140 and the second controller 240 are integrated may be disposed in either the first cabinet 110 or the second cabinet 210.

[0083] FIG. 3 is a rear perspective view of a laundry treating apparatus 1 according to an embodiment of the present disclosure.

[0084] The second cabinet 210 may be seated on the first cabinet 110, and may include a rear bracket 190 connecting the first cabinet 110 with the second cabinet 210. The rear bracket 190 may be coupled to both the rear panel 119 of the first cabinet 110 and the second cabinet 210 to prevent the second cabinet 210 from moving rearward on the first cabinet 110, and may correspond to a handle that a user may grip when moving the first treating apparatus 100 and the second treating apparatus 200.

[0085] FIG. 4 shows a state in which the first treating apparatus 100 and the second treating apparatus 200

are separated from each other in an embodiment of the present disclosure. In FIG. 4, the second treating apparatus 200 is in a state of being separated upward from the first treating apparatus 100.

[0086] In an embodiment of the present disclosure, the first cabinet 110 may include the top panel 300 that defines the top surface of the first treating apparatus 100 and supports the second cabinet 210. The top panel 300 may shield interior of the first cabinet 110 at a top of the first cabinet 110 and may support the second cabinet 210 seated thereon upward.

[0087] The second cabinet 210 may include the base 400 that may define the bottom surface of the second treating apparatus 200 and may be supported on the top panel 300. The base 400 may be supported and fixed on the top panel 300, and may provide an installation space for installing various components inside the second cabinet 210.

[0088] The base 400 may be in direct contact with the top panel 300 and mounted on the top panel 300, or may be seated on the top panel 300 via an intermediate member. The second treating apparatus 200 may be mounted so as to be stacked on the first treating apparatus 100 in a manufacturing process or a living space for actual use.

[0089] FIG. 5 is a top perspective view of the top panel 300 of the first cabinet 110 in an embodiment of the present disclosure, and FIG. 6 is a bottom perspective view of the top panel 300.

[0090] The top panel 300 may have an efficient shape for seating and supporting the second cabinet 210 by considering the various internal components disposed inside the first cabinet 110, a shape of the base 400 of the second cabinet 210, or the like.

[0091] For example, the top panel 300 may include a leg seating portion 310 in which the second cabinet 210 is directly supported. The leg seating portion 310 may include a plurality of leg seating portions. FIG. 5 shows the top panel 300 including a first leg seating portion 310a, a second leg seating portion 310b, a third leg seating portion 310c, and a fourth leg seating portion 310d according to an embodiment of the present disclosure.

[0092] The leg seating portion 310 may be defined by recessing a portion of the first cabinet 110 away from the base 400 of the second cabinet 210. The leg seating portion 310 may include a leg seating surface 312 on which the base 400 of the second cabinet 210 is supported.

[0093] In one example, the top panel 300 may include a first guide rib 370 for guiding the base 400 of the second cabinet 210 to an installation location and suppressing unnecessary movement. The first guide rib 370 may be disposed on a guide surface 322 defined in the top panel 300.

[0094] The top panel 300 may include a control surface 332 positioned above the first controller 140 disposed inside the first cabinet 110 and raised higher than the guide surface 322. The control surface 332 may be

formed as a portion of the top panel 300 protrudes upward, and may be positioned higher than the guide surface 322 with respect to the ground.

[0095] The control surface 332 may include a space that is in communication with the interior of the first cabinet 110, and at least a portion of the first controller 140 may be located inside the control surface 332. The control surface 332 may be located in front of the guide surface 322 such that a separation distance from the control panel is reduced.

[0096] The top panel 300 may include a raised portion 340 that is raised higher than the guide surface 322. The raised portion 340 may be formed as a portion of the top panel 300 protrudes upward. The raised portion 340 may have a space defined therein that is in communication with the interior space of the first cabinet 110.

[0097] The first treating apparatus 100 may be designed to wash the laundry, the detergent supply 150 for supplying the detergent into the tub 125 may be disposed inside the first cabinet 110, and the detergent supply 150 may be located below the raised portion 340.

[0098] At least a portion of the detergent supply 150 may be located in the space defined by the raised portion 340. That is, at least the portion of the detergent supply 150 may be accommodated inside the raised portion 340, and a raised surface 342 defined in the raised portion 340 may be defined as a detergent supply surface because it is raised to define the space for the detergent supply 150.

[0099] The top panel 300 may include a recessed surface 352. The recessed surface 352 may have a recessed shape so as to be located lower than the guide surface 322. The recessed surface 352 may be defined as a portion of the top panel 300 is recessed so as to be positioned lower than the guide surface 322.

[0100] The recessed surface 352 may include a first recessed surface 353 and a second recessed surface 354, and the second recessed surface 354 may be formed by being recessed further than the first recessed surface 353. That is, the second recessed surface 354 may be formed by being recessed so as to be positioned lower than the first recessed surface 353.

[0101] FIG. 7 is a bottom view of the base 400 of the second cabinet 210 according to an embodiment of the present disclosure. The base 400 may have a shape for being effectively seated on the top panel 300.

[0102] For example, the second cabinet 210 may include a leg 410 that protrudes toward the top panel 300 and is supported by the top panel 300, and the leg 410 may be disposed on the base 400.

[0103] The leg 410 may include a plurality of legs. FIG. 7 shows a first leg 410a, a second leg 410b, a third leg 410c, and a fourth leg 410d disposed at respective corner areas of the base 400, whose cross-sectional shape is approximately a square.

[0104] The base 400 may include a second guide rib 470 that is disposed adjacent to the first guide rib 370 of the top panel 300 while the second cabinet 210 is seated on the first cabinet 110. The second guide rib 470 may be

formed in a shape extending downward from the base 400.

[0105] The base 400 may include an accommodation space 420 for accommodating the raised portion 340 of the top panel 300 therein. The accommodation space 420 may be positioned above the raised portion 340 and formed with an area size equal to or greater than that of the raised portion 340, so that at least a portion of the raised portion 340 may be accommodated. The accommodation space 420 may be formed as a portion of the base 400 is recessed away from the top panel 300.

[0106] In one example, a portion of the base 400 may form a protruding surface 430 that protrudes toward the top panel 300. The base 400 may accommodate various components on the protruding surface 430. That is, the base 400 may be formed with the protruding surface 430 that protrudes downward to secure a space for accommodating the various components disposed inside the second cabinet 210.

[0107] For example, the second treating apparatus 200 may be designed to dry the laundry, and may include an air circulator 440 for supplying air into the second drum 220 to dry the laundry, and may include a fluid circulator 450 for heating air existing in the air circulator 440.

[0108] In this case, at least portions of the air circulator 440 and the fluid circulator 450 may be disposed on the base 400 and at least portions of the air circulator 440 and the fluid circulator 450 may be installed on the protruding surface 430 inside the second cabinet 210. That is, the protruding surface 430 may protrude downward so as to define a space for installing at least the portions of the air circulator 440 and the fluid circulator 450 on the base 400 inside the second cabinet 210.

[0109] FIG. 8 is a top view of the top panel 300 according to an embodiment of the present disclosure. Referring to FIG. 8, the top panel 300 may include the guide surface 322, the control surface 332, the raised surface 342, and the recessed surface 352 described above, and may include the leg seating portion 310 in which the leg 410 of the base 400 is seated.

[0110] The leg seating portion 310 may be disposed at each vertex area of the top panel 300 for load distribution efficiency. The guide surface 322 on which the first guide rib 370 is positioned may be defined in a portion of the top panel 300, and the control surface 332 that protrudes higher than the guide surface 322 may be disposed in front of the guide surface 322.

[0111] The guide surface 322 may be positioned biasedly at one side in a lateral direction, and the raised surface 342 of the raised portion 340 described above may be disposed at the other side. The raised portion 340 or the raised surface 342 may be formed in a shape that extends approximately in a front and rear direction.

[0112] The recessed surface 352 may be disposed at the rear of the guide surface 322. The recessed surface 352 may have the second recessed surface 354 disposed within the first recessed surface 353. The raised surface 342 formed in the shape that extends in the front

and rear direction may be disposed at one side in the lateral direction of the top panel 300, and the guide surface 322 and the recessed surface 352 may be positioned at the other side.

[0113] FIG. 9 is a bottom view of the base 400 according to an embodiment of the present disclosure. In FIG. 9, locations corresponding to the guide surface 322, the control surface 332, the raised surface 342, and the recessed surface 352 of the top panel 300 are indicated as dotted lines, respectively.

[0114] The second guide rib 470 may be disposed on the base 400 at a location corresponding to the guide surface 322 of the top panel 300. A space may be defined to be recessed in front of the second guide rib 470 to accommodate the control surface 332 of the top panel 300 therein, and the accommodation space 420 may be defined to be recessed in an area corresponding to the raised surface 342 to accommodate the raised surface 342 therein.

[0115] The protruding surface 430 may be disposed at the rear of the guide surface 322. The protruding surface 430 may include a first protruding surface 431 positioned within the first recessed surface 353 of the top panel 300, and a second protruding surface 432 positioned within the second recessed surface 354 of the top panel 300.

[0116] However, the location of each area in the top panel 300 may be variously changed as needed. For example, various changes are possible, such as the control surface 332 being positioned rearward of the guide surface 322, or the recessed surface 352 being positioned forward of the guide surface 322. The base 400 may be designed to correspond to the structure of the top panel 300.

[0117] FIG. 10 shows the leg 410 disposed on the second cabinet 210 in an embodiment of the present disclosure, and FIG. 11 shows the leg seating portion 310 of the top panel 300 in which the leg 410 in FIG. 10 is to be seated.

[0118] The top panel 300 may include the leg seating portion 310 that is recessed away from the second cabinet 210 and in which the leg 410 is seated and supported. The leg seating portion 310 may be formed as the portion of the top panel 300 is recessed inward of the first cabinet 110. The leg seating portion 310 may have a shape of a groove recessed downward.

[0119] The leg seating portion 310 may have a cross-sectional shape corresponding to a cross-section of the leg 410. A cross-sectional area of the leg seating portion 310 may be equal to or greater than a cross-sectional area of the leg 410. The leg 410 of the second cabinet 210 may be supported by being inserted at least partially into the leg seating portion 310.

[0120] The second cabinet 210 may be seated on the first cabinet 110 and supported as the leg 410 is accommodated in the leg seating portion 310. That is, the second cabinet 210 may be supported on the first cabinet 110 by the leg 410 accommodated in the leg seating portion 310.

[0121] There may be various shapes of the leg 410. Although FIG. 10 shows the leg 410 having a circular cross-section according to an embodiment of the present disclosure, the present disclosure may not be necessarily limited thereto, and a length of the leg 410 may vary as needed.

[0122] The leg 410 may extend downward from the second cabinet 210. The leg 410 may be disposed on at least one of the front panel 112, the rear panel 119, the side panel 115, and the base 400. FIG. 10 shows the leg 410, which is formed to protrude downward from the base 400, according to an embodiment of the present disclosure.

[0123] A space that is open toward the leg seating portion 310 may be defined inside the leg 410. That is, the leg 410 may be formed in a pipe or cylindrical shape such that the space may be defined therein. The space defined in the leg 410 may be open toward the top panel 300. That is, the leg 410 may include the space that is open downward.

[0124] As the leg 410 includes the space that is opened downward, a molding process of the leg 410 may be improved, and a product quality of the molded leg 410 may be improved by a slimming effect. Furthermore, as will be described later, an additional leg 412 or the like may be installed as needed, thereby enabling various uses of the leg 410.

[0125] As described above, the second cabinet 210 may include the base 400 that defines the bottom surface of the second treating apparatus 200, and the leg 410 may extend downward from the base 400.

[0126] That is, in an embodiment of the present disclosure, the leg 410 may be disposed on the base 400, and the second cabinet 210 may be supported by the top panel 300 via the leg 410 disposed on the base 400. The leg 410 may be formed integrally with the base 400, or may be manufactured separately and coupled to the base 400.

[0127] The leg 410 may be formed in a shape of a hollow column. That is, the leg 410 may be formed in the shape of the pipe, the cylinder, or a polygonal column.

[0128] In FIG. 10, the additional leg 412 coupled to the leg 410 is conceptually shown. Referring to FIG. 10, in an embodiment of the present disclosure, the leg 410 may be coupled with the additional leg 412 that may be inserted into the space within the leg 410.

[0129] The additional leg 412 may be inserted into the space defined in the leg 410 and coupled to the leg 410. The additional leg 412 may be additionally extended from the leg 410 or may have a shape advantageous for being supported from the ground or the like.

[0130] In an embodiment of the present disclosure, the second treating apparatus 200 may be seated on top of the first treating apparatus 100 and handled together, but in some cases, only the second treating apparatus 200 may be utilized independently. In this case, the second cabinet 210 may be supported by the ground or the like rather than the top panel 300 of the first cabinet 110.

[0131] In an embodiment of the present disclosure, the leg 410 may be extended in the length or have rigidity reinforced as the additional leg 412 is coupled thereto, and further, may have an increased size of an area in contact with the ground so as to be easily supported by the ground or the like.

[0132] In addition, the second treating apparatus 200 may be manufactured with the additional leg 412 coupled to the leg 410 in consideration of sole use thereof, and when the second treating apparatus 200 is used together with the first treating apparatus 100, the additional leg 412 may be removed to simply implement the stack structure of the first treating apparatus 100 and the second treating apparatus 200.

[0133] That is, in an embodiment of the present disclosure, the leg 410 may be formed in the hollow shape such that the additional leg 412 may be coupled thereto. Therefore, it may be easy to implement the sole use of the second treating apparatus 200 or the stack structure with the first treating apparatus 100 as needed, and furthermore, the manufacturing process may be simplified so as to be conveniently applied to both the sole use and the stacked use, which are advantageous.

[0134] In one example, the base 400 may include a leg reinforcing rib 414 that extends away from the leg 410 along a radial direction of the leg 410. The leg reinforcing rib 414 may extend along a longitudinal direction of the leg 410 and may extend away from the leg 410.

[0135] When the space is defined inside the leg 410 to improve usability, such as the coupling of the additional leg 412, the rigidity of the leg 410 may be reduced. An embodiment of the present disclosure may secure sufficient rigidity for the leg 410 to support the second cabinet 210 via the leg reinforcing rib 414 extending from the leg 410.

[0136] The leg reinforcing rib 414 may include a plurality of leg reinforcing ribs. For example, the plurality of leg reinforcing ribs 414 may be provided for one leg 410. The leg reinforcing rib 414 may extend along the radial direction of the leg 410. The leg reinforcing rib 414 may effectively improve the rigidity of the leg 410 by connecting the leg 410 and another component on the base 400.

[0137] In one example, the top panel 300 may include a plurality of surfaces that are parallel to the ground but have different vertical levels. Referring again to FIG. 5, an embodiment of the present disclosure may include the plurality of surfaces that have the different vertical levels relative to the ground, such as the guide surface 322 and the raised surface 342.

[0138] The top panel 300 may have the various internal components disposed inside the first cabinet 110 below, and the base 400 may be seated thereon. That is, the top panel 300 may be designed to enable stable seating of the base 400 by considering securing of the installation space for the various internal components inside the first cabinet 110, and further, considering a shape of the bottom surface of the base 400.

[0139] For example, a portion of the top panel 300

where the internal component of the first cabinet 110 is disposed below may be raised upward to secure the arrangement space for the internal component, and a portion where the downwardly protruding portion of the base 400 is seated may be recessed downward to facilitate the accommodation of the base 400.

[0140] In an embodiment of the present disclosure, the plurality of surfaces defined in the top panel 300 may be defined by a vertical level difference or the like. That is, when adjacent surfaces have different vertical levels, the adjacent surfaces may be defined as different surfaces.

[0141] The surfaces of the top panel 300 may generally be formed parallel to the ground, but may also be formed in an inclined shape when necessary. In addition, the number and shape of surfaces of the top panel 300 may be determined variously as necessary.

[0142] In an embodiment of the present disclosure, as the plurality of surfaces with the different vertical levels are formed on the top panel 300, the space in which the internal component of the first cabinet 110 is disposed may be effectively secured while the base 400 may be efficiently seated, which may be advantageous in terms of space utilization and in reducing a total height of the laundry treating apparatus 1.

[0143] In one example, as shown in FIG. 11, the top panel 300 may include a first surface and a second surface having a different vertical level from the first surface, the leg seating portion 310 may include the plurality of leg seating portions, and at least one of the plurality of leg seating portions may be formed on a boundary between the first surface and the second surface.

[0144] The top panel 300 may include the various surfaces, such as the guide surface 322, the control surface 332, the raised surface 342, the recessed surface 352, and the like, as described above. Each of the first surface and the second surface may be one of the various surfaces formed on the top panel 300.

[0145] The first surface and the second surface may be surfaces adjacent to each other. That is, the boundary between the first surface and the second surface may be formed between the first surface and the second surface. That is, the boundary between the first surface and the second surface having the different vertical levels may correspond to a stepped portion where the vertical level changes.

[0146] In one example, the vertical levels of the first surface and the second surface may be determined by considering the shape of the base 400 or the internal component of the first cabinet 110 as described above. For example, the second surface may have a higher vertical level than the first surface such that the internal component of the first cabinet 110 may be disposed below.

[0147] However, separately from the determination of the vertical levels of the first surface and the second surface, the formation of the leg seating portion 310 for the stable support of the second cabinet 210 is important. Accordingly, even when the first surface and the second

surface with the different vertical levels are formed, the leg seating portion 310 may be formed across the boundary between the first surface and the second surface as needed.

[0148] Accordingly, in an embodiment of the present disclosure, when the first surface and the second surface are formed for the efficient arrangement of the internal components or the stable seating of the base 400, a locational change of the first surface and the second surface may be minimized and the leg seating portion 310 may be formed at a location corresponding to the leg 410 of the base 400.

[0149] In other words, in an embodiment of the present disclosure, the leg seating portion 310 may be disposed at the location corresponding to the leg 410 of the base 400, and the first surface and the second surface may be effectively arranged as needed without necessarily avoiding the leg seating portion 310.

[0150] FIGS. 5 and 11 show the plurality of legs 410 formed on the top panel 300 and the first leg 410a formed at the boundary between the first surface and the second surface having the different vertical levels, according to an embodiment of the present disclosure.

[0151] FIG. 12 is a side cross-sectional view of the base 400 seated on the top panel 300 in an embodiment of the present disclosure.

[0152] Referring to FIGS. 11 and 12, in an embodiment of the present disclosure, the leg seating portion 310 may include the leg seating surface 312 that supports a lower end of the leg 410 and has a lower vertical level than the first surface and the second surface.

[0153] The plurality of legs 410 may have the same length protruding from the base. That is, the plurality of leg seating portions 310 defined in the top panel 300 may have different depths of recession because of a difference in the location therebetween, but the leg seating surfaces 312 on which the respective legs 410 are supported may all have the same vertical level relative to the ground.

[0154] Accordingly, the first leg 410a formed at the boundary between the first surface and the second surface may also include the leg seating surface 312 having the same vertical level as that of the second leg 410b or the like, and the leg seating surface 312 may be positioned lower than the first surface and the second surface. That is, the leg 410 formed at the boundary between the first surface and the second surface may have a shape that is recessed to be lower than the first surface and the second surface.

[0155] FIG. 11 shows that the first surface is defined at a border of the top panel 300, the second surface is defined as the aforementioned control surface 332, and the first leg seating portion 310a among the leg seating portions 310 is formed at the boundary between the first surface and the second surface, as an embodiment of the present disclosure.

[0156] The second surface that has the higher vertical level than the first surface may have a shape that is

partially invaded by the leg seating portion 310. The second surface may have a boundary with respect to the leg seating portion 310, and the leg seating portion 310 may have a location that inwardly invades the second surface.

[0157] However, because the leg seating surface 312 of the first leg seating portion 310a in FIG. 11 has a lower vertical level than the first surface, the first surface may also have a boundary with respect to the first leg seating portion 310a. The boundary between the first surface and the leg seating portion 310 may form a periphery of the leg seating portion 310 together with the boundary between the second surface and the leg seating portion 310.

[0158] The periphery of the leg seating portion 310 in the second surface may form a boundary in a form of a curved or bent straight line at a border of the second surface. FIG. 11 shows that the boundary with respect to the leg seating portion 310 is formed in a partial circular form in the second surface, but the shape of the boundary is not necessarily limited thereto.

[0159] In one example, in an embodiment of the present disclosure, the second surface may have the higher vertical level than the first surface, the first treating apparatus 100 may include the internal component that is disposed inside the first cabinet 110 and has at least a portion positioned below the second surface.

[0160] In an embodiment of the present disclosure, the top panel 300 may include the surfaces with the various vertical levels, and as described above, some of the plurality of surfaces may be raised to secure the arrangement space of the internal component disposed inside the first cabinet 110.

[0161] In an embodiment of the present disclosure, the second surface may have a location higher than that of the first surface, and one of the internal components disposed inside the first cabinet 110 may be disposed below the same. At least the portion of the internal component may be disposed in the space created by the raising of the second surface.

[0162] For example, in an embodiment of the present disclosure, the first treating apparatus 100 may include the driver 130 that rotates the first drum 120, and the internal component may correspond to at least a portion of the first controller 140 that controls the driver 130 and performs a laundry treatment course.

[0163] In this case, the second surface may correspond to the control surface 332 described above. That is, the first treating apparatus 100 may include the first controller 140 that is disposed inside the first cabinet 110 and controls the driver 130 that rotates the first drum 120 to perform the laundry treatment course, and the top panel 300 may include the control surface 332 that is positioned higher than the guide surface 322 and has at least the portion of the first controller 140 disposed below.

[0164] The control surface 332 may be positioned above the first controller 140 for receiving a command signal from the control panel and controlling the driver 130 in the first cabinet 110. That is, the top panel 300 may

have the area defined as the control surface 332 raised relative to a surrounding area thereof, so that the space may be defined below the control surface 332 as shown in FIG. 6. When viewed from the inside of the first cabinet 110, the space of the first cabinet 110 may be secured with the additional space as the control surface 332 is formed to be raised.

[0165] FIG. 4 conceptually shows the first controller 140 positioned below the control surface 332. The first controller 140 may be positioned below the control surface 332, and at least the portion thereof may be positioned in the space defined by the increase in the vertical level of the control surface 332.

[0166] There may be various shapes of the control surface 332. The control surface 332 may have a cross-sectional shape corresponding to the first controller 140, and may be further raised in a relationship with the surroundings, such as the first surface.

[0167] FIG. 4 shows that the control surface 332 has a shape that extends along the lateral direction of the first cabinet 110. The control surface 332 may be positioned adjacent to the guide surface 322 and/or the raised surface 342 described above, thereby forming a boundary with respect to the guide surface 322 and/or the raised surface 342.

[0168] FIG. 4 or the like shows that the control surface 332 is positioned in the front portion of the top panel 300 at the rear of the front panel 112, and the first controller 140 is positioned below the control surface 332.

[0169] The control surface 332 may be positioned biasedly at one side in the lateral direction of the top panel 300. For example, the side panel 115 of the first cabinet 110 may include a first side panel 116 positioned at one side in the lateral direction, and a second side panel 117 positioned at a side opposite thereto, and the control surface 332 may be positioned closer to the second side panel 117 than to the first side panel 116.

[0170] In the top panel 300, one of the plurality of leg seating portions 310 may be positioned between the control surface 332 and the first side panel 116. FIG. 4 or the like shows the fourth leg seating portion 310d positioned between the control surface 332 and the second side panel 117.

[0171] When the second surface described above corresponds to the control surface 332, a portion of the control surface 332 may be recessed by the leg seating portion 310. That is, a periphery of the control surface 332 may be defined to include a portion of the periphery of the leg seating portion 310.

[0172] FIG. 4 or the like shows that a portion of a periphery of the first leg seating portion 310a corresponds to a portion of the periphery of the control surface 332, and thus, a boundary between the two is formed. In this case, the first controller 140 may be positioned so as not to interfere with the leg seating portion 310.

[0173] For example, the first controller 140 may be positioned below the control surface 332 but not below the first leg seating portion 310a, or a portion of the first

controller 140 positioned below the first leg seating portion 310a may be positioned below the leg seating surface 312 of the first leg seating portion 310a.

[0174] However, in an embodiment of the present disclosure, the first surface and the second surface described above may not be necessarily limited as corresponding to the control surface 332 and the surrounding surface thereof, and the first surface and the second surface may correspond to surfaces other than the control surface 332 or the like, depending on an arrangement relationship between the leg seating portion 310 and the various surfaces of the top panel 300.

[0175] The raised portion 340 of the top panel 300 is shown in FIG. 4 or the like. As described above, in an embodiment of the present disclosure, the leg 410 of the second treating apparatus 200 may protrude toward the top panel 300 and be supported by the top panel 300, and the top panel 300 may include the leg seating portion 310 in which the leg 410 is seated.

[0176] In addition, the first cabinet 110 may include the front panel 112 defining the front surface of the first treating apparatus 100, the raised portion 340 may be spaced rearwardly apart from the front panel 112, and the leg seating portion 310 may be positioned between the raised portion 340 and the front panel 112.

[0177] That is, in an embodiment of the present disclosure, the top panel 300 may form the raised portion 340 where the portion thereof is raised higher than the surroundings, and the raised portion 340 may be spaced rearwardly apart from the front panel 112 to provide an area in which at least one of the plurality of leg seating portions 310 may be defined.

[0178] In an embodiment of the present disclosure, the raised portion 340 may correspond to the aforementioned control surface 332, or may be formed as a surface different from the control surface 332. For example, the raised portion 340 may include the raised surface 342 having a vertical level different from that of the control surface 332.

[0179] The raised portion 340 may also have the effect of expanding the internal space of the first cabinet 110. Accordingly, at least one of the various internal components of the first cabinet 110 may be disposed inside the raised portion 340, that is, below the raised surface 342.

[0180] In an embodiment of the present disclosure, the top panel 300 may be formed to contain a metal material such as iron, aluminum, stainless steel, and the like. Accordingly, it may be advantageous for the top panel 300 to be molded to include the surfaces with the different vertical levels via a drawing method, a press method, and the like. In one example, the top panel 300 made of and molded with the metal material as above may include a grounding portion 360 for removing residual current or the like.

[0181] In one example, in an embodiment of the present disclosure, the base 400 may be formed to contain a polymer material having excellent formability, such as plastic. Accordingly, it may be advantageous for the base

400 to be molded to have a relatively detailed and specific shape via general injection molding, insert injection molding, and the like.

[0182] For example, the base 400 may have a shape corresponding to each component of the fluid circulator 450 and the air circulator 440, may be advantageous in defining a space in which each component described above is disposed, and may be advantageous in forming the leg 410 or the like whose internal space is opened downward, integrally with the base 400.

[0183] In one example, as described above, the portion of the second surface, which is raised higher in the relationship with the first surface or the like, may be recessed to form the leg seating portion 310. However, in this case, an interference relationship with the internal component disposed below the second surface should be considered. To avoid such limitation, the raised portion 340 may be spaced rearwardly apart from the front panel 112 to define the arrangement area of the leg seating portion 310.

[0184] FIG. 4 or the like shows the raised portion 340 that is positioned biasedly at the other side in the lateral direction of the top panel 300, and shows that the raised portion 340 is disposed rearwardly apart from a front end of the top panel 300, and the fourth leg seating portion 310d is formed between the raised portion 340 and the front end of the top panel 300, that is, the front panel 112.

[0185] In one example, in an embodiment of the present disclosure, the detergent supply 150 among the internal components of the first cabinet 110 may be positioned below the raised portion 340. In this case, the raised surface 342 of the raised portion 340 may be defined as the detergent supply surface.

[0186] That is, in an embodiment of the present disclosure, the detergent supply surface may be spaced rearwardly apart from the front panel 112, the leg seating portion 310 may include the plurality of leg seating portions, and at least one of which may be positioned between the detergent supply surface and the front panel 112.

[0187] In this regard, the phrase "between the detergent supply surface and the front panel 112" is described based on a front and rear direction of the first cabinet 110. The leg seating portion 310 may not necessarily be located at a location facing the front panel 112 forward or a location facing the detergent supply surface rearward.

[0188] In one example, in an embodiment of the present disclosure, among the plurality of leg seating portions 310, the first leg seating portion 310a and the fourth leg seating portion 310d described above may be positioned at a front side of the top panel 300, and the second leg seating portion 310b and the third leg seating portion 310c may be positioned at a rear side of the top panel 300.

[0189] In this regard, the front side and the rear side of the top panel 300 may be defined differently depending on the case, but may basically be distinguished based on

a center of the top panel 300, and may also be distinguished based on the raised portion 340, the guide surface 322, or the like when necessary.

[0190] In an embodiment of the present disclosure, the first cabinet 110 may include the rear panel 119 defining the rear surface of the first treating apparatus 100 and the first side panel 116 defining a first side surface. The rear panel 119 may be positioned at the rear of the leg seating portion 310, the first side panel 116 may be positioned on a first side of the leg seating portion 310, and the raised portion 340 may be positioned in front of and on a second side of the leg seating portion 310.

[0191] That is, in an embodiment of the present disclosure, one of the plurality of leg seating portions 310 may be surrounded by the rear panel 119, the first side panel 116, and the raised portion 340 based on the front and rear direction and the left and right direction.

[0192] The third leg seating portion 310c will be specifically described with reference to FIG. 8 as follows. First, in an embodiment of the present disclosure, the raised portion 340 may be extended in the front and rear direction, and may be positioned in front of the rear panel 119.

[0193] In one example, as described above, the plurality of leg seating portions 310 may be positioned at the respective vertex areas of the top panel 300 for the stable support of the second cabinet 210 and the effective load distribution.

[0194] For example, the third leg seating portion 310c may be positioned at a vertex area formed as the first side panel 116 and the rear panel 119 meet each other. Accordingly, the rear panel 119 may be positioned at the rear of the third leg seating portion 310c, and the first side panel 116 may be positioned on the first side.

[0195] In one example, at least a portion of the raised portion 340 may be positioned around the third leg seating portion 310c. Accordingly, the raised portion 340 may be positioned in front of and on the second side of the third leg seating portion 310c. Considering the arrangement location of the third leg seating portion 310c, the raised portion 340 may be formed in a shape in which a portion of the corner is recessed.

[0196] That is, a portion corresponding to the vertex area defined by the rear panel 119 and the first side panel 116 in the raised portion 340 may not be raised. That is, the raised portion 340 may be raised except for the vertex area.

[0197] FIG. 8 shows the raised portion 340 having a peripheral shape bent around the third leg seating portion 310c for the arrangement of the third leg seating portion 310c. Specifically, the raised portion 340 may include a raised side surface extending upward from the top panel 300 and the raised surface 342 connected to the raised side surface, and a portion of the raised side surface may be positioned to face the third leg seating portion 310c.

[0198] For example, the raised side surface may include a first raised side surface 346 located in front of the third leg seating portion 310c and a second raised side

surface 347 located on the second side of the third leg seating portion 310c. The first raised side surface 346 and the second raised side surface 347 may be connected to each other and may define a portion of the periphery of the raised portion 340.

[0199] Accordingly, the raised portion 340 may have a shape in which a portion of the corner is recessed inward by the first raised side surface 346 and the second raised side surface 347. That is, the raised surface 342 of the raised portion 340 may have a peripheral shape in which the portion facing the third leg seating portion 310c is recessed away from the third leg seating portion 310c.

[0200] In one example, as described above, in an embodiment of the present disclosure, when the detergent supply 150 is positioned below the raised portion 340, the raised surface 342 of the raised portion 340 may also be defined as the detergent supply surface.

[0201] In this case, in an embodiment of the present disclosure, the leg seating portion 310 may include the plurality of leg seating portions, and one of those may have the rear panel 119 positioned at the rear thereof, the first side panel 116 positioned on the first side thereof, and the detergent supply surface positioned in front thereof and on the second side thereof.

[0202] In this case, the detergent supply 150 may also be disposed or shaped to avoid structural interference with the third leg seating portion 310c.

[0203] An embodiment of the present disclosure may have the peripheral shape in which the portion of the raised portion 340 is recessed away from the vertex area defined by the rear panel 119 and the first side panel 116, thereby maximizing an area size of the raised portion 340 while effectively forming the leg seating portion 310 in the vertex area.

[0204] In addition, the raised surface 342 may be positioned higher relative to the guide surface 322, and the control surface 332 may also be positioned higher than the guide surface 322. The vertical level relationship between the raised surface 342 and the control surface 332 may vary. For example, as shown in FIG. 5, the raised surface 342 may be positioned higher than the control surface 332.

[0205] The raised surface 342 may be positioned higher than an upper end of the side panel 115 of the first cabinet 110, and may be positioned lower than an upper end of the front panel 112 of the first cabinet 110. For example, the upper end of the front panel 112 of the first cabinet 110 may be positioned highest among the components of the first treating apparatus 100.

[0206] In one example, an embodiment of the present disclosure may include the recessed surface 352 positioned lower than the guide surface 322 as described above, the second cabinet 210 may include the base 400 defining the bottom surface of the second treating apparatus 200, and the base 400 may include the protruding surface 430 facing the recessed surface 352 and protruding toward the recessed surface 352.

[0207] Referring to FIGS. 8 and 9, the recessed sur-

face 352 and the protruding surface 430 will be described as follows. In an embodiment of the present disclosure, the top panel 300 may include the recessed surface 352, and the recessed surface 352 may be located lower than the guide surface 322.

[0208] The protruding surface 430 of the base 400 may be positioned above the recessed surface 352. The protruding surface 430 of the base 400 may be a surface protruding from the base 400 toward the top panel 300, and a portion of the fluid circulator 450 or the like may be positioned above the protruding surface 430 inside the second cabinet 210.

[0209] The recessed surface 352 of the top panel 300 may define the space in which the protruding surface 430 of the base 400 is accommodated. That is, the protruding surface 430 of the base 400 may be at least partially disposed in the space defined above the first cabinet 110 by the recessed surface 352.

[0210] In an embodiment of the present disclosure, the portion of the top panel 300 is recessed to define the recessed surface 352, so that even when the protruding surface 430 protrudes from the base 400, the base 400 may be stably supported on the top panel 300.

[0211] The recessed surface 352 and the protruding surface 430 may have peripheral shapes corresponding to each other. Alternatively, the recessed surface 352 may be formed to have an area size at least greater than that of the protruding surface 430 to define the space in which the protruding surface 430 is accommodated. In FIG. 9, an area corresponding to the recessed surface 352 of the top panel 300 is indicated by a dotted line.

[0212] In one example, the recessed surface 352 may include the first recessed surface 353 positioned lower than the guide surface 322 and the second recessed surface 354 positioned lower than the first recessed surface 353. That is, the top panel 300 may include the plurality of surfaces whose vertical levels are lowered in a multi-stage manner.

[0213] The first recessed surface 353 may surround at least a portion of a periphery of the second recessed surface 354. FIG. 8 shows a shape in which the second recessed surface 354 rearwardly faces the rear panel 119 and a remaining periphery except for the rear side is surrounded by the first recessed surface 353.

[0214] In one example, the first recessed surface 353 may be formed to include one of the plurality of vertex areas formed on the top panel 300, and at least one of the plurality of leg seating portions 310 may be positioned on the first recessed surface 353.

[0215] For example, the first recessed surface 353 may be formed to include a vertex area defined by the rear panel 119 and the second side panel 117, and the second leg seating portion 310b positioned in the vertex area may be positioned on the first recessed surface 353. The second leg seating portion 310b may be positioned to be spaced apart from the second recessed surface 354. That is, the second recessed surface 354 may be formed to be spaced apart from the second leg seating

portion 310b.

[0216] In one example, the protruding surface 430 may include the first protruding surface 431 positioned above the first recessed surface 353 and the second protruding surface 432 positioned above the second recessed surface 354 and protruding beyond the depth of the first recessed surface 353.

[0217] That is, the protruding surface 430 formed on the base 400 may include the first protruding surface 431 and the second protruding surface 432, and correspondingly, the recessed surface 352 of the top panel 300 may also include the first recessed surface 353 and the second recessed surface 354.

[0218] The protruding surface 430 of the base 400 may expand the space inside the second cabinet 210 by protruding toward the top panel 300, thereby securing the space for the internal component of the second cabinet 210 to be disposed.

[0219] Furthermore, when a plurality of components are installed on top of the protruding surface 430, a different amount of additional space may be required depending on each component, and accordingly, in an embodiment of the present disclosure, the protruding surface 430 of the base 400 may be composed of a plurality of surfaces having different amounts of protrusion.

[0220] That is, the protruding surface 430 may include the first protruding surface 431 and the second protruding surface 432 that protrudes more than the first protruding surface 431, and an internal component of the second cabinet 210 positioned on the second protruding surface 432 may have a greater height than a component positioned on the first protruding surface 431.

[0221] In one example, the recessed surface 352 may also include the first recessed surface 353 for allowing the protrusion amount of the first protruding surface 431, and may include the second recessed surface 354 for allowing the protrusion amount of the second protruding surface 432.

[0222] The recession depth of the first recessed surface 353 may correspond to the protrusion amount of the first protruding surface 431, and a recession depth of the second recessed surface 354 may correspond to the protrusion amount of the second protruding surface 432. For example, the recession depth of the first recessed surface 353 may be equal to or greater than the protrusion amount of the first protruding surface 431, and the recession depth of the second recessed surface 354 may be equal to or greater than the protrusion amount of the second protruding surface 432.

[0223] In addition, the recessed surface 352 may have an area size equal to or greater than that of the protruding surface 430. That is, the recessed surface 352 may be formed in a shape corresponding to the protruding surface 430, or may have the periphery that is at least greater than the periphery of the protruding surface 430.

[0224] Likewise, the first recessed surface 353 may have an area size equal to or greater than that of the first

protruding surface 431, and the first recessed surface 353 may have a shape corresponding to the first protruding surface 431 or may have a periphery that is at least greater than a periphery of the first protruding surface 431.

[0225] The second recessed surface 354 may have an area size equal to or greater than that of the second protruding surface 432, and the second recessed surface 354 may have a shape corresponding to the second protruding surface 432 or may have a periphery that is at least greater than a periphery of the first protruding surface 431.

[0226] FIG. 4 or the like shows the grounding portion 360 formed on the top panel 300, and FIG. 13 is a top view of the grounding portion 360. Referring to FIG. 13, in an embodiment of the present disclosure, the top panel 300 may include the grounding portion 360 that is recessed downward and to which a grounding line 362 is connected.

[0227] Specifically, the various internal components may be present inside the first cabinet 110, and some of the internal components may consume power. That is, the first treating apparatus 100 may operate while consuming the power, and the grounding portion 360 may be disposed to eliminate the residual current.

[0228] The grounding portion 360 may be disposed on the first cabinet 110. The grounding portion 360 may be disposed on the top panel 300 of the first cabinet 110. The grounding line 362 may be connected to the grounding portion 360. One end of the grounding line 362 may be positioned on the grounding portion 360 of the top panel 300 and coupled to the grounding portion 360 so as to be in contact therewith.

[0229] In one example, the grounding portion 360 may extend along an edge of the top panel 300. That is, the grounding portion 360 may be formed at at least a portion of the edge of the top panel 300. In addition, the grounding portion 360 may be opened outward of the top panel 300 along a direction parallel to the ground.

[0230] For example, the grounding portion 360 may be formed in a recessed shape at the edge of the top panel 300 and may be opened in a direction away from the top panel 300. Because the grounding portion 360 is formed in the open shape as described above, the grounding line 362 connected to the grounding portion 360 may extend outward of the grounding portion 360.

[0231] The grounding portion 360 may include a grounding surface to which the grounding line 362 is connected and a grounding side surface 365 extending along an edge of the grounding surface. For example, a bottom surface of the grounding portion 360 recessed from the top panel 300 may be defined as the grounding surface, and the grounding portion 360 may include the grounding side surface 365 positioned around an edge of the grounding surface.

[0232] At least a portion of the grounding side surface 365 may extend at an angle with respect to an extension direction of the grounding portion 360. That is, at least the

portion of the grounding side surface 365 may extend at an angle with respect to an extension direction of the edge of the top panel 300. That is, at least the portion of the grounding side surface 365 may extend diagonally with respect to the front and rear direction or the lateral direction of the top panel 300.

[0233] For example, the grounding side surface 365 may include an inclined surface extending at an angle. One end of the inclined surface may be located at the outermost edge of the top panel 300. In FIG. 5, the grounding portion 360 is disposed on a portion of an edge of the top panel 300 facing the second side panel 117, the grounding portion 360 is opened to the second side, and the inclined surface extending at an angle toward the second side is shown.

[0234] The grounding line 362 connected to the grounding portion 360 may be coupled to the grounding surface at a location adjacent to the inclined surface. The grounding line 362 may be coupled to the grounding portion 360 by an extending member that rotates and extends through the grounding line 362 and the grounding surface, such as a bolt.

[0235] The inclined surface that extends at an angle in the grounding side surface 365 may extend at an angle away from the grounding line 362. Accordingly, the grounding line 362 that is rotated by the rotation of the extending member may be completely coupled in a state in which the rotation thereof is limited by being in contact with the inclined surface.

[0236] In this case, an extension direction of the grounding line 362 may be approximately parallel to the extension direction of the inclined surface, so that the grounding line 362 may be coupled to the grounding portion 360 while minimizing bending of the grounding line 362 or the like.

[0237] FIG. 14 shows the first guide rib 370 positioned on the top panel 300 according to an embodiment of the present disclosure. Referring to FIG. 14, in an embodiment of the present disclosure, the top panel 300 may include the first guide rib 370 for guiding the location of the base 400.

[0238] Specifically, the first guide rib 370 may protrude from the top panel 300 toward the second cabinet 210 and extend in a first direction D1 to suppress movement of the second cabinet 210. The first guide rib 370 may be positioned on the guide surface 322 of the top panel 300, but may not be necessarily limited thereto.

[0239] In other words, in an embodiment of the present disclosure, the first guide rib 370 may be disposed on one of the top surface of the first cabinet 110 and the bottom surface of the second cabinet 210, may protrude toward the other of the top surface of the first cabinet 110 and the bottom surface of the second cabinet 210, and may extend along the first direction D1 to suppress movement of the other along a second direction D2 intersecting the first direction D1.

[0240] Specifically, the first guide rib 370 may protrude from the top panel 300 toward the base 400, and thus may

make contact with the base 400. That is, the base 400 may be induced to the coupling process or the coupling location via a contact relationship with the first guide rib 370 on the top panel 300, and may be restricted from moving out of the coupling location.

[0241] As described above, the laundry treating apparatus 1 according to an embodiment of the present disclosure may have the second treating apparatus 200 seated on the first treating apparatus 100, and the second treating apparatus 200 may be seated by moving downward onto the first treating apparatus 100, or may be mutually coupled with the first treating apparatus 100 by further including a sliding process or the like after the seating.

[0242] Furthermore, the second treating apparatus 200 seated on the first treating apparatus 100 may be subject to vibration or external force generated during the laundry treatment process, in which case, unintended movement of the second treating apparatus 200 may occur on the first treating apparatus 100.

[0243] That is, when the second treating apparatus 200 deviates from the exact coupling location during the process of being seated on the first treating apparatus 100, or when the unintended movement occurs even though the second treating apparatus 200 is positioned at the exact coupling location, the second treating apparatus 200 may not be fully supported by the first treating apparatus 100 or unspecified damage may occur.

[0244] To prevent this, in an embodiment of the present disclosure, the top panel 300 may include the first guide rib 370 protruding, and the base 400 may be guided in the coupling location or may be restricted from the unintended movement by a structural interference relationship with the first guide rib 370. The first guide rib 370 may protrude from the base 400 toward the top panel 300 in some cases.

[0245] In one example, in an embodiment of the present disclosure, the top panel 300 may include the guide surface 322 facing the second cabinet 210 and having the first guide rib 370 disposed thereon. The guide surface 322 may provide an area where the first guide rib 370 may be positioned, and may correspond to a surface parallel to the ground. The first guide rib 370 may protrude higher than the guide surface 322.

[0246] The guide surface 322 may be distinguished from the control surface 332, the raised surface 342, and the recessed surface 352 described above. For example, the guide surface 322 may have a vertical level different from that of the control surface 332 or the like. For example, as shown in FIG. 14, the control surface 332 may be positioned in front of the guide surface 322, the raised surface 342 may be positioned lateral to the guide surface 322, and the recessed surface 352 may be positioned at the rear of the guide surface 322. The guide surface 322, the control surface 332, the raised surface 342, and the recessed surface 352 may have different vertical levels.

[0247] In one example, the first guide rib 370 may

protrude toward the second cabinet 210 and extend along the first direction D1 to suppress the movement of the second cabinet 210. That is, the first guide rib 370 may have a rib shape that protrudes from the guide surface 322 and extends in the first direction D1.

[0248] The first direction D1 may be determined in various ways. In FIG. 14, the first guide rib 370 where the first direction D1 is determined to be approximately parallel to the front and rear direction of the first cabinet 110 is shown, but the present disclosure is not necessarily limited thereto.

[0249] The first guide rib 370 may suppress the second cabinet 210 from moving in a direction intersecting the first direction D1. That is, the first guide rib 370 may extend along the first direction D1, and may suppress the base 400 from moving beyond the first guide rib 370 in the second direction D2 intersecting the first direction D1.

[0250] When the first guide rib 370 extends in the front and rear direction, the base 400 may be restricted from moving laterally by the structural interference relationship, that is, the contact with the first guide rib 370.

[0251] For example, when the second treating apparatus 200 is seated on the first treating apparatus 100 and coupled thereto via the sliding process, the first direction D1 corresponding to the extension direction of the first guide rib 370 may be parallel to a sliding direction of the second treating apparatus 200.

[0252] Accordingly, even when the first guide rib 370 is formed on the top panel 300, the base 400 of the second treating apparatus 200 may slide along the first direction D1 on the top panel 300. Even when the second treating apparatus 200 is coupled to the first treating apparatus 100 without the sliding process, the first guide rib 370 may guide the coupling location of the second treating apparatus 200 based on the lateral direction.

[0253] In one example, the first guide rib 370 may be positioned so as to be spaced apart from the edge of the top panel 300. When the second treating apparatus 200 is coupled onto the first treating apparatus 100, the first guide rib 370 may be accommodated in the base 400 and may be covered from the outside by the second cabinet 210.

[0254] FIG. 15 shows the second guide rib 470 disposed on the base 400 according to an embodiment of the present disclosure. Referring to FIG. 15, the second cabinet 210 may include the second guide rib 470 that protrudes toward the top panel 300 and extends along the first direction D1, and the first guide rib 370 may be positioned adjacent to the second guide rib 470 and suppress the movement of the second cabinet 210.

[0255] Specifically, the second guide rib 470 may protrude downward from the base 400. For example, the second guide rib 470 may protrude from the base 400 to the guide surface 322 of the top panel 300. The second guide rib 470 may be positioned adjacent to the first guide rib 370 along the second direction D2.

[0256] The second guide rib 470 may extend parallel to the first guide rib 370. That is, the second guide rib 470

may have the shape of the rib extending along the first direction D1 like the first guide rib 370.

[0257] The second guide rib 470 is positioned adjacent to the first guide rib 370, so that a movement thereof in the second direction D2 may be restricted via a contact relationship with the first guide rib 370. That is, the second guide rib 470 may be restricted from moving in the second direction D2 by the first guide rib 370, and accordingly, the movement of the base 400 and the second cabinet 210 in the second direction D2 may be restricted.

[0258] In one example, the first guide rib 370 may include a plurality of first guide ribs arranged along the direction intersecting the first direction D1, and the second guide rib 470 may include a plurality of second guide ribs arranged along the direction intersecting the first direction D1 and positioned between the plurality of first guide ribs 370.

[0259] FIG. 16 shows a state in which the base 400 is seated on the top panel 300, and the first guide rib 370 and the second guide rib 470 are positioned adjacent to each other.

[0260] Referring to FIG. 16, the first guide rib 370 may be disposed on the guide surface 322, and the second guide rib 470 may also be positioned on the guide surface 322 from the base 400. The first guide rib 370 may include at least two first guide ribs, and the at least two first guide ribs may be arranged along the second direction D2.

[0261] FIG. 16 shows that the first guide rib 370 includes a pair of first guide ribs, and the pair of first guide ribs extend along the first direction D1 and are arranged to be spaced apart from each other along the second direction D2. However, the number of first guide ribs 370 and an arrangement scheme thereof may vary as needed.

[0262] In one example, the second guide rib 470 may be positioned between the plurality of first guide ribs 370. For example, as shown in FIG. 16, the second guide rib 470 may be positioned between the pair of first guide ribs 370.

[0263] Accordingly, the second guide rib 470 may be restricted from moving to both sides along the second direction D2. That is, the second guide rib 470 may be restricted from deviating from an area between the pair of first guide ribs 370 along the second direction D2 by structural interference.

[0264] The number of second guide ribs 470 may correspond to the number of first guide ribs 370. For example, a pair of second guide ribs 470 may be disposed between the pair of first guide ribs 370.

[0265] Each of the plurality of second guide ribs 470 may be positioned adjacent to each of the first guide ribs 370. That is, the pair of second guide ribs 470 may be positioned between the pair of first guide ribs 370 so as to face and be adjacent to the different first guide ribs 370, respectively.

[0266] For example, each of the pair of second guide ribs 470 may be positioned adjacent to the first guide rib

370 and facing the same outward, based on a center that may be defined between the pair of second guide ribs 470.

[0267] Accordingly, when the base 400 attempts to move to one side based on the second direction D2, the movement may be restricted by one of the second guide ribs 470 coming into contact with a first guide rib 370 located outward, and when the base 400 attempts to move to the other side, the movement may be restricted by the other of the second guide ribs 470 coming into contact with a first guide rib 370 located outward.

[0268] That is, in an embodiment of the present disclosure, the first guide rib 370 and the second guide rib 470 may include the pair of first guide ribs and the pair of second guide ribs, respectively, and the pair of second guide ribs 470 may be positioned between the pair of first guide ribs 370 and be suppressed from moving in the direction intersecting the first direction D1.

[0269] In one example, the plurality of first guide ribs 370 may be arranged along the second direction D2 intersecting the first direction D1, and a center made by the plurality of first guide ribs 370 with respect to the second direction D2 may be positioned biasedly toward the first side panel 116 or the second side panel 117.

[0270] For example, the plurality of first guide ribs 370 may be arranged such that the center of the pair of first guide ribs 370 positioned at outermost sides with respect to the second direction D2 are closer to the second side panel 117 than to the first side panel 116. This may be equally applied to the second guide rib 470.

[0271] In one example, in an embodiment of the present disclosure, an extension length L1 of the first guide rib 370 along the first direction D1 may be smaller than a length LA of the top panel 300 along the first direction D1. As described above, the first guide rib 370 may be disposed on the guide surface 322 of the top panel 300.

[0272] The surface having the different vertical level, such as the control surface 332 or the recessed surface 352, may be present in front of or at the rear of the guide surface 322, and accordingly, the first guide rib 370 may have the extension length L1 smaller than the length LA of the top panel 300 such that the surface having the vertical level different from that of the guide surface 322 may be formed.

[0273] In addition, the first guide rib 370 may be positioned to be spaced apart from the leg seating portion 310. Accordingly, the first guide rib 370 may not interrupt the seating of the leg 410 in the leg seating portion 310 and may suppress the movement of the base.

[0274] FIG. 17 shows the upper end of the front panel 112 positioned in front of the second cabinet 210 and the rear bracket 190 in the laundry treating apparatus 1 according to an embodiment of the present disclosure. Referring to FIG. 17, the front panel 112 may protrude higher than a front end of the top panel 300 to restrict forward movement of the second cabinet 210.

[0275] Specifically, in an embodiment of the present

disclosure, the first guide rib 370 and the second guide rib 470 may extend along the first direction D1, and the first direction D1 may be parallel to the front and rear direction of the first cabinet 110.

[0276] In addition, the first guide rib 370 and the second guide rib 470 may include the plurality of first guide ribs and the plurality of second guide ribs, respectively, that are arranged adjacent to each other along the second direction D2 intersecting the first direction D1, and the second direction D2 may be parallel to the lateral direction of the first cabinet 110.

[0277] That is, the first guide rib 370 and/or the second guide rib 470 may extend in the front and rear direction to restrict lateral movement of the base 400.

[0278] In one example, the front panel 112 of the first cabinet 110 may protrude upward from the first cabinet 110. That is, the upper end of the front panel 112 may be positioned higher than the top panel 300 or an upper end of the side panel 115.

[0279] Accordingly, the upper end of the front panel 112 may be positioned in front of the base 400, and may restrict the base 400 from moving forward from the complete coupling location.

[0280] That is, an embodiment of the present disclosure may restrict the lateral movement of the second cabinet 210, that is, the base 400, using the first guide rib 370 and/or the second guide rib 470, while restricting the forward movement of the base 400 using the front panel 112, thereby maintaining a stable coupling structure.

[0281] In one example, an embodiment of the present disclosure may further include the rear bracket 190 coupled to the second cabinet 210 at a rear side of the first cabinet 110. The rear bracket 190 may protrude upward from a rear end of the top panel 300 to restrict rearward movement of the second cabinet 210.

[0282] The rear bracket 190 may be coupled to the rear panel 119 of the first cabinet 110 and the second cabinet 210 together. That is, at least a portion of the rear bracket 190 may be positioned at the rear of the base 400. The rear bracket 190 may restrict the rearward movement of the second cabinet 210 via structural interference.

[0283] The rear bracket 190 may have a lower portion coupled to the first cabinet 110 at the rear of the first cabinet 110, and may have an upper portion coupled to the second cabinet 210 at the rear of the second cabinet 210. The rear bracket 190 may extend along the lateral direction of the first cabinet 110.

[0284] An embodiment of the present disclosure may restrict the movement in the front and rear direction of the second cabinet 210 via the first guide rib 370 and/or the second guide rib 470 extending in the front and rear direction of the first cabinet 110, may restrict the forward movement thereof via the front panel 112, and may restrict the rearward movement thereof via the rear bracket 190.

[0285] Accordingly, the second cabinet 210 including the base 400 may be effectively restricted from moving unintentionally in the front and rear direction and the left

and right direction, and the coupling location thereof may also be effectively guided.

[0286] In one example, in an embodiment of the present disclosure, the guide surface 322 having a lower vertical level than the raised surface 342 of the raised portion 340 may be disposed in at least a portion of a remaining portion of the top panel 300 excluding the raised portion 340. The guide surface 322 may include the first guide rib 370 that protrudes toward the second cabinet 210 and extends along the first direction D1 to suppress the movement of the second cabinet 210.

[0287] In addition, at least a portion of the raised surface 342 may be positioned lateral to the guide surface 322, and the first guide rib 370 may extend in a direction intersecting the lateral direction on the guide surface 322.

[0288] FIG. 18 shows the raised portion 340 disposed on the top panel 300 in an embodiment of the present disclosure. Referring to FIG. 18, the top panel 300 may include the raised portion 340 that is raised toward the second cabinet 210 and defines therein a raised space in communication with the interior of the first cabinet 110.

[0289] In addition, the first treating apparatus 100 may include the internal component that is disposed inside the first cabinet 110 and at least partially positioned in the raised space. For example, at least the portion of the internal component of the first treating apparatus 100 may be positioned in the space defined by the raised portion 340.

[0290] That is, a portion of the top surface of the first cabinet 110 may be raised higher than the remaining portion such that the internal component of the first treating apparatus 100 is positioned therein, and a portion of the bottom surface of the second cabinet 210 may define a space in which the raised portion of the top surface of the first cabinet 110 is accommodated.

[0291] As described above, the raised portion 340 may include the raised surface 342 positioned at a top of the raised space, and a remaining portion of the top panel 300 excluding the raised surface 342 may be positioned lower than the raised surface 342.

[0292] In an embodiment of the present disclosure, the internal component positioned below the raised surface 342 may correspond to the detergent supply 150. That is, the first treating apparatus 100 may further include the tub 125 that is disposed inside the first cabinet 110, and includes the first drum 120 therein to accommodate water.

[0293] The internal component may correspond to the detergent supply 150 that stores the detergent therein and supplies the detergent into the tub 125. The detergent supply 150 may be disposed inside the first cabinet 110, and may store the detergent therein and supply the detergent to the tub 125. At least a portion of the detergent supply 150 may be located below the raised surface 342.

[0294] In addition, as described above, when at least the portion of the detergent supply 150 is located below the raised surface 342, the raised surface 342 may also

be defined as the detergent supply surface. That is, an embodiment of the present disclosure may include the detergent supply surface that is located higher than the guide surface 322 and has at least the portion of the detergent supply 150 disposed below.

[0295] FIG. 19 shows the accommodation space 420 defined in the base 400 according to an embodiment of the present disclosure.

[0296] The accommodation space 420 may be defined as a portion of the base 400 facing the raised surface 342 is recessed upward, and may accommodate the raised surface 342 therein. A shape of the raised surface 342 is indicated by a dotted line in FIG. 19.

[0297] The accommodation space 420 may be formed in a shape corresponding to the raised surface 342, or may be formed to have an area size greater than that of the raised surface 342. In an embodiment of the present disclosure, the space in which the internal component of the first treating apparatus, such as the detergent supply 150, is disposed may be effectively secured as the raised portion 340 is formed on the top panel 300, and further, the base 400 may be stably seated on the top panel 300 on which the raised portion 340 is formed as the accommodation space 420 is defined in the base 400.

[0298] FIG. 20 shows the detergent supply 150 disposed inside the first cabinet 110 according to an embodiment of the present disclosure. In FIG. 20, a shape of the raised surface 342 is indicated by a dotted line.

[0299] Referring to FIG. 20, the first cabinet 110 may include the first side panel 116 defining the first side surface of the first treating apparatus 100 and the second side panel 117 defining the second side surface, and the raised portion 340 and the detergent supply 150 may be positioned closer to the first side panel 116 than to the second side panel 117.

[0300] Specifically, in an embodiment of the present disclosure, the detergent supply 150 may be positioned at an upper side of the first cabinet 110 so as to be conveniently used by a user. In addition, to avoid structural interference with the tub 125, which is roughly cylindrical in shape with a central axis thereof facing forward, the detergent supply 150 may be positioned biasedly to one side in the lateral direction.

[0301] For example, the detergent supply 150 may be positioned adjacent to the first side panel 116 at the upper side of the first cabinet 110. The detergent supply 150 may also be in contact with the first side panel 116. Depending on the location of the detergent supply 150, the raised portion 340 may also be formed on the top panel 300 adjacent to the first side panel 116.

[0302] In one example, in an embodiment of the present disclosure, the detergent supply 150 may include a protruding portion 151 protruding toward the raised portion 340 and positioned within the raised space. In addition, the detergent supply 150 may further include a non-protruding portion 152 positioned outside the raised space.

[0303] Specifically, the detergent supply 150 may in-

clude a space where the detergent is stored, and may include a flow channel for water mixed with the detergent and supplied to the tub 125. That is, it is important for the detergent supply 150 to secure the storage space for the detergent or the like.

[0304] To this end, in an embodiment of the present disclosure, the detergent supply 150 may include the protruding portion 151 protruding toward the raised portion 340. The protruding portion 151 may correspond to the flow channel for water, or may correspond to the storage space for the detergent.

[0305] However, the detergent supply 150 may include the non-protruding portion 152 that is distinguished from the protruding portion 151 and located outside the raised space. In this case, the protruding portion 151 of the detergent supply 150 may be inserted into the space of the raised portion 340, and the non-protruding portion 152 may be located outside the raised space.

[0306] In this regard, the raised space, as the space defined by the raised portion 340, may mean the space located below the raised surface 342, surrounded by the raised side surface, and open into the first cabinet 110.

[0307] Accordingly, only a portion of the detergent supply 150 may protrude and expand and be utilized as the storage space for the detergent or the like by using the raised space of the raised portion 340, and the remaining portion thereof may not protrude and expand to avoid an unnecessary increase in the area size of the raised surface 342.

[0308] In one example, in an embodiment of the present disclosure, the raised portion 340 may be spaced rearwardly apart from the front panel 112, and at least a portion of the non-protruding portion 152 may be positioned in front of the protruding portion 151 to correspond to an area between the front panel 112 and the raised portion 340.

[0309] The protruding portion 151, as an area that protrudes upward from the detergent supply 150 and expands in volume, may be positioned within the raised space of the raised portion 340. In one example, the non-protruding portion 152 may not protrude upward, unlike the protruding portion 151, and may be positioned between the front panel 112 and the protruding portion 151.

[0310] The leg seating portion 310 may be positioned above the non-protruding portion 152. That is, an embodiment of the present disclosure may improve space utilization by allowing only the specific portion of the detergent supply 150 to protrude and be accommodated in the raised space, while the rest does not protrude such that the various areas of the top panel 300 may be defined.

[0311] FIG. 21 is an exploded view of the detergent supply 150 according to an embodiment of the present disclosure. Referring to FIG. 21, the detergent supply 150 may include a water supply unit 157, a detergent storage 155, and a detergent casing 156.

[0312] The water supply unit 157 may be positioned on the detergent casing 156 and may supply water into the

detergent casing 156. When the first treating apparatus 100 is designed to wash the laundry, the first treating apparatus 100 may be connected to an external water supply source that supplies water from outside the first cabinet 110.

[0313] A water supply valve 161 may be connected to the external water supply source and may regulate a flow of water. The water supply unit 157 may be connected to the water supply valve 161 via a water supply hose 162 to receive water. The water supply unit 157 may supply water into the detergent casing 156 or to the detergent storage 155 located beneath the same.

[0314] The detergent casing 156 may be located beneath the water supply unit 157, and may accommodate the detergent storage 155 therein. That is, the detergent casing 156 may have a space defined therein in which the detergent storage 155 is accommodated.

[0315] The detergent storage 155 may store the detergent therein. The detergent storage 155 may include a space in which the detergent is stored, and at least a portion thereof may be extended from the interior of the detergent casing 156 to the outside of the first cabinet 110.

[0316] The user may extend the detergent storage 155 out of the first cabinet 110, store the detergent therein, and then retract the detergent storage 155 back into the first cabinet 110, that is, into the detergent casing 156.

[0317] When a washing process of the laundry is performed, the water supply valve 161 may open to supply water to the water supply unit 157, the water supply unit 157 may discharge water into the detergent storage 155 and/or the detergent casing 156, and the detergent stored in the detergent storage 155 may be mixed with water discharged from the water supply unit 157 and delivered from the interior of the detergent casing 156 to the tub 125.

[0318] In an embodiment of the present disclosure, at least a portion of the water supply unit 157 may be located within the raised space of the raised portion 340. That is, the detergent supply 150 may include the protruding portion 151 that protrudes upward from the water supply unit 157, is positioned inside the raised space, and has the flow channel for water formed therein.

[0319] That is, the protruding portion 151 may correspond to at least a portion of the water supply unit 157. The water supply unit 157 may include the flow channel of water for water supplied via the water supply hose 162 to flow, and a space for forming the flow channel needs to be secured.

[0320] Furthermore, to increase a storage amount of the detergent, a size of the detergent storage 155 needs to be increased eventually, and an increase in a volume of the detergent storage 155 or the formation of the flow channel in the water supply unit 157 may eventually lead to an increase in a vertical level of an upper end of the water supply unit 157 located at a front side of the detergent supply 150.

[0321] That is, in the detergent supply 150, at least a

portion of the water supply unit 157 may protrude upward to form the protruding portion 151, and the protruding portion 151 may be accommodated in the raised space. The protruding portion 151 may correspond to a portion where the flow channel of the water supply unit 157 is formed.

[0322] FIG. 22 shows a cross-section taken along a line A-A in FIG. 18. FIG. 22 shows the protruding portion 151 of the water supply unit 157 accommodated in the raised space. As such, as at least a portion of the water supply unit 157 protrudes upward and is accommodated in the raised space, a separation distance between the detergent supply 150 and the tub 125 may be effectively secured.

[0323] In one example, the raised portion 340 may be spaced rearwardly apart from the front panel 112, and the water supply unit 157 may include the non-protruding portion 152 positioned in front of the protruding portion 151 and disposed outside the raised space.

[0324] For example, a front end of the water supply unit 157 may be defined as the non-protruding portion 152, and a portion that is located at the rear of the non-protruding portion 152 and where the flow channel of water is formed may be defined as the protruding portion 151. The detergent supply 150 may be connected to the front panel 112 and extend rearward.

[0325] In an embodiment of the present disclosure, a portion of the water supply unit 157 that does not require expansion may be maintained in a non-protruding state, and thus the area size of the raised portion 340 may be reduced, thereby minimizing unnecessary space consumption.

[0326] In one example, the detergent supply 150 may further include a detergent hose 159 that is connected to the water supply unit 157 and delivers the detergent of the detergent storage 155 to the protruding portion 151, and a hose insertion groove 153 into which the detergent hose 159 is inserted and extends may be defined to be recessed in a top surface of the protruding portion 151.

[0327] Specifically, referring again to FIG. 20, in an embodiment of the present disclosure, the detergent stored in the detergent storage 155 may be supplied into the detergent casing 156 after passing through the water supply unit 157 via the detergent hose 159.

[0328] To this end, the detergent supply 150 may include a detergent pump 158 connected to the detergent storage 155 to pump the detergent, and the detergent pump 158 may be connected to the detergent hose 159 to deliver the detergent to the water supply unit 157 via the detergent hose 159.

[0329] As described above, the water supply unit 157 may form the flow channel for water to flow within the protruding portion 151, and the detergent hose 159 may be connected to the protruding portion 151 to supply the detergent into the protruding portion 151.

[0330] Accordingly, the water supply unit 157 may allow water and the detergent to flow within the protruding portion 151, and may discharge water and the detergent

together into the detergent casing 156 and deliver them to the tub 125.

[0331] In one example, as described above, an embodiment of the present disclosure may form the raised portion 340 on the top panel 300 to maximize the space utilization within the first cabinet 110. However, when the detergent hose 159 for supplying the detergent to the protruding portion 151 of the water supply unit 157 protrudes upward from the protruding portion 151, an unnecessary increase in height may occur based on the entire detergent supply 150, which may be disadvantageous.

[0332] Accordingly, in an embodiment of the present disclosure, the water supply unit 157 may have the hose insertion groove 153 defined therein into which at least a portion of the detergent hose 159 may be inserted and extend in the protruding portion 151.

[0333] Accordingly, an upward protrusion amount of the detergent hose 159 extended upward from the water supply unit 157 may be minimized, thereby enabling efficient use of the raised space. The hose connector 154 to which the detergent hose 159 is connected in the protruding portion 151 may also extend in a direction parallel to the detergent hose 159 and be positioned to be recessed downward from the protruding portion 151 to minimize the protrusion amount of the detergent hose 159.

[0334] That is, the protruding portion 151 may further include the hose connector 154 connected to the detergent hose 159, and the hose connector 154 may extend in a direction parallel to the raised surface 342 of the raised portion 340 inside the hose insertion groove 153 and may be connected to the detergent hose 159.

[0335] As shown in FIG. 22, the detergent supply 150 may further include the detergent pump 158 that is coupled to the detergent casing 156 from outside the detergent casing 156 and pumps the detergent of the detergent storage 155.

[0336] The detergent pump 158 may be connected to the detergent storage 155 and may pump the detergent stored in the detergent storage 155. The detergent storage 155 may be accommodated inside the detergent casing 156, and the detergent pump 158 may be positioned outside the detergent casing 156 to facilitate expansion of a storage capacity of the detergent storage 155.

[0337] The detergent pump 158 may be connected to the detergent storage 155 by being coupled with the detergent casing 156 at the rear of the detergent casing 156. The detergent pump 158 may be located below the raised surface 342 of the raised portion 340. Accordingly, the raised surface 342 may have a shape that extends longer than the water supply unit 157, and may effectively secure a space where the detergent pump 158 is located inside the first cabinet 110.

[0338] FIG. 23 is a cross-sectional view taken along a line B-B in FIG. 18. Referring to FIG. 23, the first treating apparatus 100 may further include the water supply hose

162 that transfers water supplied from an external water supply source to the detergent supply 150, and the water supply valve 161 that is connected to the water supply hose 162 and regulates the flow of water.

[0339] The water supply valve 161 may be positioned below the raised surface 342 of the raised portion 340. That is, in an embodiment of the present disclosure, the raised portion 340 may secure a space for placing not only the detergent supply 150 but also the water supply valve 161 or the like.

[0340] The water supply valve 161 may be positioned at a rear side inside the first cabinet 110. The water supply valve 161 may be connected to and fixed to the rear panel 119. The water supply valve 161 may be positioned at the rear of the detergent supply 150. In addition, the water supply valve 161 may be positioned laterally spaced apart from the detergent pump 158 to minimize interference with the detergent pump 158 and the detergent hose 159.

[0341] Accordingly, the raised portion 340 may have a shape in which a rear portion thereof is laterally expanded relative to the remaining portion such that at least a portion of the water supply valve 161 may be positioned within the raised space. For example, the raised portion 340 may include a first portion having a first width based on the lateral direction of the first cabinet 110 and a second portion having a second width greater than the width of the first portion.

[0342] The second portion may be connected to the first portion from the rear of the first portion. The first raised side surface 346 and the second raised side surface 347 of the raised portion 340 described above may correspond to a portion of a periphery of the second portion. In addition, the water supply valve 161 may be positioned below a portion of the second portion whose width is greater than that of the first portion.

[0343] An embodiment of the present disclosure may raise the portion of the top panel 300 to have a greater height to form the raised portion 340, and may effectively secure a space for the internal component, such as the detergent supply 150 as well as the detergent pump 158 and the water supply valve 161 related thereto to be disposed, via the raised space of the raised portion 340.

[0344] FIG. 24 shows the recessed surface 352 according to an embodiment of the present disclosure. Referring to FIG. 24, in an embodiment of the present disclosure, the top panel 300 may further include the recessed surface 352 positioned lower than the guide surface 322, and the first guide rib 370 may be disposed on the guide surface 322 excluding the recessed surface 352.

[0345] That is, the top panel 300 may include the recessed surface 352 positioned lower than the guide surface 322 with respect to the ground, the second cabinet 210 may include the base 400 defining the bottom surface of the second treating apparatus 200, and the base 400 may include the protruding surface 430 facing the recessed surface 352 and protruding toward the

recessed surface 352.

[0346] The recessed surface 352 may be formed as the portion of the top panel 300 is recessed downward. For example, the recessed surface 352 may have a lower vertical level than the guide surface 322. A depth of the recessed surface 352 may correspond to the protrusion amount of the protruding surface 430 of the base 400.

[0347] Referring to FIG. 24, at least a portion of the recessed surface 352 may be disposed adjacent to the guide surface 322 along the front and rear direction. That is, the recessed surface 352 may correspond to a stepped surface in a relationship with the guide surface 322.

[0348] The raised surface 342 may be positioned lateral to the recessed surface 352. That is, the raised surface 342 may include the first portion having the first width and the second portion having the second width as described above. The raised surface 342 may be positioned adjacent to the first side panel 116, the guide surface 322 may be positioned between the first portion of the raised surface 342 and the second side panel 117, and the recessed surface 352 may be positioned between the second portion of the raised surface 342 and the second side panel 117. The raised surface 342, the guide surface 322, and the recessed surface 352 may be formed stepwise relative to each other, respectively.

[0349] In one example, as described above, the recessed surface 352 may include the first recessed surface 353 positioned lower than the guide surface 322 and the second recessed surface 354 positioned lower than the first recessed surface 353. The formation of the first recessed surface 353 and the second recessed surface 354 may be determined in a relationship with the protruding surface 430 of the base 400.

[0350] FIG. 25 shows the protruding surface 430 of the base 400 according to an embodiment of the present disclosure. In FIG. 25, an area corresponding to the recessed surface 352 of the top panel 300 is indicated by a dotted line.

[0351] Referring to FIG. 25, as described above, the protruding surface 430 of the base 400 may include the first protruding surface 431 positioned on the first recessed surface 353, and the second protruding surface 432 positioned on the second recessed surface 354 and protruding further than the first recessed surface 353.

[0352] The bottom surface of the base 400 may include various protruding components such as the rib as well as a surface flat to the ground. The protruding surface 430 of the base 400 may be formed as a surface roughly flat to the ground.

[0353] FIG. 26 is a view of the base 400 according to an embodiment of the present disclosure as viewed from inside the second cabinet 210. Referring to FIG. 26, the second treating apparatus 200 may include the fluid circulator 450 that is disposed on the protruding surface 430 inside the second cabinet 210, circulates fluid, and supplies or receives heat to or from air.

[0354] That is, the second treating apparatus 200 may

be designed to dry the laundry, and accordingly, may include the fluid circulator 450 as a means for heating air to provide high-temperature dry air into the second drum 220.

[0355] The fluid circulator 450 may correspond to a heat pump system. That is, the fluid circulator 450 corresponds to an apparatus in which the fluid circulates through a condenser, a compressor 452, an expansion valve, an evaporator, and the like, and exchanges heat with the outside, that is, air.

[0356] The second treating apparatus 200 may include the air circulator 440 that is dehumidified and heated by the fluid circulator 450. A portion of the fluid circulator 450 may be exposed to an air flow channel formed in the air circulator 440, so that the heat exchange between air and the fluid may occur.

[0357] In an embodiment of the present disclosure, the air circulator 440 may be positioned above the raised portion 340, and at least a portion of the fluid circulator 450 may be positioned above the recessed surface 352. However, this is merely an example, and various arrangements may be considered.

[0358] In an embodiment of the present disclosure, the fluid circulator 450 may be disposed on the base 400, circulate the fluid, and supply or receive heat to or from air, and at least a portion of the fluid circulator 450 may be positioned above the recessed surface 352.

[0359] That is, at least a portion of the base 400 may protrude downward to secure a space for at least a portion of the fluid circulator 450 to be installed, thereby forming the protruding surface 430 of the base 400. In addition, the top panel 300 may form the recessed surface 352 such that the protruding surface 430 is accommodated therein and thus the base 400 is completely seated therein.

[0360] The fluid circulator 450 may include the compressor 452 that compresses the fluid and a cooling fan 454 that cools the compressor 452, the compressor 452 may be positioned on the first protruding surface 431, and the cooling fan 454 may be positioned on the second protruding surface 432.

[0361] The compressor 452 may have a relatively great height for operational efficiency, and accordingly, an installation space of the compressor 452 may need to secure a relatively great spatial margin. Accordingly, in an embodiment of the present disclosure, the protruding surface 430 may be formed on the base 400, and the compressor 452 may be disposed on the protruding surface 430.

[0362] In addition, the fluid circulator 450 may include the cooling fan 454 for reducing heat generated during operation of the compressor 452. The cooling fan 454 may also be positioned adjacent to the compressor 452, and may require an installation space having a great height corresponding to the compressor 452.

[0363] Accordingly, in an embodiment of the present disclosure, a floor of the area where the compressor 452 and the cooling fan 454 are installed may protrude down-

ward from the base 400 to effectively secure the installation space of the compressor 452 and the cooling fan 454.

[0364] In one example, in an embodiment of the present disclosure, the compressor 452 may be positioned on the first protruding surface 431, and the cooling fan 454 may be positioned on the second protruding surface 432. Protrusion amounts of the first protruding surface 431 and the second protruding surface 432 may be equal to each other, or the protrusion amount of the second protruding surface 432 may be greater than that of the first protruding surface 431.

[0365] However, in an embodiment of the present disclosure, the component disposed on the protruding surface 430 is not necessarily limited to the compressor 452 or the cooling fan 454. For example, a portion of the air circulator 440 or the remainder of the fluid circulator 450 excluding the compressor 452 may be disposed on the protruding surface 430.

[0366] In an embodiment of the present disclosure, the surfaces with the various vertical levels may be formed at the top panel 300 to effectively secure the internal space of the first cabinet 110 or to effectively accommodate the protruding portion of the base 400.

[0367] Likewise, an embodiment of the present disclosure may determine the shape of the bottom surface of the base 400 so as to effectively secure the internal space of the second cabinet 210 or effectively accommodate the protruding portion of the top panel 300.

[0368] In addition, an embodiment of the present disclosure may include the leg 410 that may be conveniently separated from or coupled to the additional leg 412 or the like, and the top panel 300 may include the leg seating portion 310 that may efficiently accommodate and support the leg 410 therein.

[0369] In addition, an embodiment of the present disclosure may effectively suppress the movement in the second direction D2 of the second cabinet 210 via the first guide rib 370 and the second guide rib 470, and further, may effectively suppress the movement in the first direction D1 of the second cabinet 210 using the front panel 112 and the rear bracket 190.

[0370] Furthermore, an embodiment of the present disclosure may be formed with the raised portion 340 to effectively secure the space for installing the detergent supply 150 or the like of the first cabinet 110, and the detergent supply 150 may be disposed by efficiently utilizing the raised space as the protruding portion 151 and the non-protruding portion 152 are distinguished from each other.

[0371] Although the present disclosure has been illustrated and described with respect to the specific embodiments, it will be apparent to those skilled in the art that the present disclosure may be variously improved and modified without departing from the technical spirit of the present disclosure provided by the following claims.

Claims

1. A laundry treating apparatus comprising:

5 a first treating apparatus including a first cabinet and a first drum disposed inside the first cabinet to accommodate laundry therein; and
 a second treating apparatus including a second cabinet disposed on top of the first cabinet, and a second drum disposed inside the second cabinet to accommodate the laundry therein,
 10 wherein the first cabinet includes a top panel defining a top surface of the first treating apparatus and supporting the second cabinet,
 wherein the second cabinet includes a leg protruding toward the top panel and supported by the top panel,
 wherein the top panel includes a leg seating portion recessed away from the second cabinet,
 15 wherein the leg is seated in the leg seating portion,
 wherein an interior of the leg is configured to open toward the leg seating portion.

20 2. The laundry treating apparatus of claim 1, wherein the leg is formed in a shape of a hollow column.

3. The laundry treating apparatus of claim 1, wherein the leg is configured to be combinable with an additional leg having at least a portion inserted into the leg.

4. The laundry treating apparatus of claim 1, wherein the second cabinet includes a base defining a bottom surface of the second treating apparatus,
 35 wherein the leg is configured to extend downward from the base.

5. The laundry treating apparatus of claim 4, wherein the base includes a leg reinforcing rib extending along a radial direction of the leg from the leg.

6. The laundry treating apparatus of claim 1, wherein the top panel includes a plurality of surfaces parallel to ground but having different vertical levels.

7. The laundry treating apparatus of claim 1, wherein the top panel includes a first surface and a second surface having a vertical level different from a vertical level of the first surface, wherein the top panel includes a plurality of leg seating portions, and at least one of the plurality of leg seating portions is positioned on a boundary between the first surface and the second surface.

8. The laundry treating apparatus of claim 7, wherein the at least one of the leg seating portions includes a leg seating surface supporting a lower end of the leg

and having a vertical level lower than the vertical levels of the first surface and the second surface.

9. The laundry treating apparatus of claim 7, wherein the vertical level of the second surface is higher than the vertical level of the first surface, wherein the first treating apparatus includes an internal component disposed inside the first cabinet and having at least a portion positioned below the second surface. 5
10. The laundry treating apparatus of claim 9, wherein the first treating apparatus includes a driver configured to rotate the first drum, wherein the internal component corresponds to at least a portion of a first controller configured to control the driver and perform a laundry treatment course. 10
11. The laundry treating apparatus of claim 1, wherein the top panel includes a grounding portion recessed downward and connected with a grounding line. 20
12. The laundry treating apparatus of claim 11, wherein the grounding portion is configured to extend along an edge of the top panel and is open outward of the top panel along a direction parallel to ground, 25
- wherein the grounding portion includes a grounding surface coupled with the grounding line, and a grounding side surface extending along an edge of the grounding surface, wherein at least a portion of the grounding side surface is configured to extend at an angle with respect to an extension direction of the grounding portion. 30
13. The laundry treating apparatus of claim 1, wherein the top panel includes a guide surface facing the second cabinet, wherein a first guide rib protruding toward the second cabinet and extending along a first direction to suppress movement of the second cabinet is disposed on the guide surface. 35
14. The laundry treating apparatus of claim 13, wherein the first treating apparatus includes a first controller disposed inside the first cabinet and configured to perform a laundry treatment course by controlling a driver configured to rotate the first drum, 40
- wherein the top panel further includes a control surface positioned higher than the guide surface, and wherein at least a portion of the first controller is disposed below the control surface. 45
15. The laundry treating apparatus of claim 13, wherein 50

the first treating apparatus includes:

- a tub disposed inside the first cabinet, having the first drum disposed therein, and configured to accommodate water therein; and a detergent supply disposed inside the first cabinet, storing detergent therein, and configured to supply the detergent into the tub, wherein the top panel includes a detergent supply surface positioned higher than the guide surface and having at least a portion of the detergent supply disposed below. 5
16. The laundry treating apparatus of claim 15, wherein the first cabinet includes a front panel defining a front surface of the first treating apparatus, 10
- wherein the detergent supply surface is spaced rearwardly apart from the front panel, wherein the leg seating portion includes a plurality of leg seating portions, and at least one of the plurality of leg seating portions is positioned between the detergent supply surface and the front panel. 15
17. The laundry treating apparatus of claim 15, wherein the first cabinet includes a rear panel defining a rear surface of the first treating apparatus and a first side panel defining a first side surface of the first treating apparatus, wherein the leg seating portion includes a plurality of leg seating portions, and one of the plurality of leg seating portions has the rear panel positioned at the rear thereof, has the first side panel on a first side thereof, and has the detergent supply surface positioned in front thereof and on a second side thereof. 20
18. The laundry treating apparatus of claim 13, wherein the top panel includes a recessed surface positioned lower than the guide surface relative to ground, 25
- wherein the second cabinet includes a base defining a bottom surface of the second treating apparatus, wherein the base includes a protruding surface facing the recessed surface and protruding toward the recessed surface. 30
19. The laundry treating apparatus of claim 18, wherein the second treating apparatus includes a fluid circulator disposed on the protruding surface within the second cabinet and configured to supply or receive heat while fluid circulates. 35
20. The laundry treating apparatus of claim 19, wherein the recessed surface includes a first recessed surface positioned lower than the guide surface and a second recessed surface positioned lower than the 40

first recessed surface.

21. The laundry treating apparatus of claim 20, wherein the leg seating portion includes a plurality of leg seating portions, and at least one of the plurality of leg seating portions is positioned on the first recessed surface. 5

22. The laundry treating apparatus of claim 20, wherein the protruding surface includes a first protruding surface positioned on the first recessed surface, and a second protruding surface positioned on the second recessed surface and protruding further than the first recessed surface. 10

23. The laundry treating apparatus of claim 22, wherein the fluid circulator includes a compressor configured to compress the fluid, and a cooling fan configured to cool the compressor, wherein the compressor is positioned on the first protruding surface, and the cooling fan is positioned on the second protruding surface. 15 20

25

30

35

40

45

50

55

FIG. 1

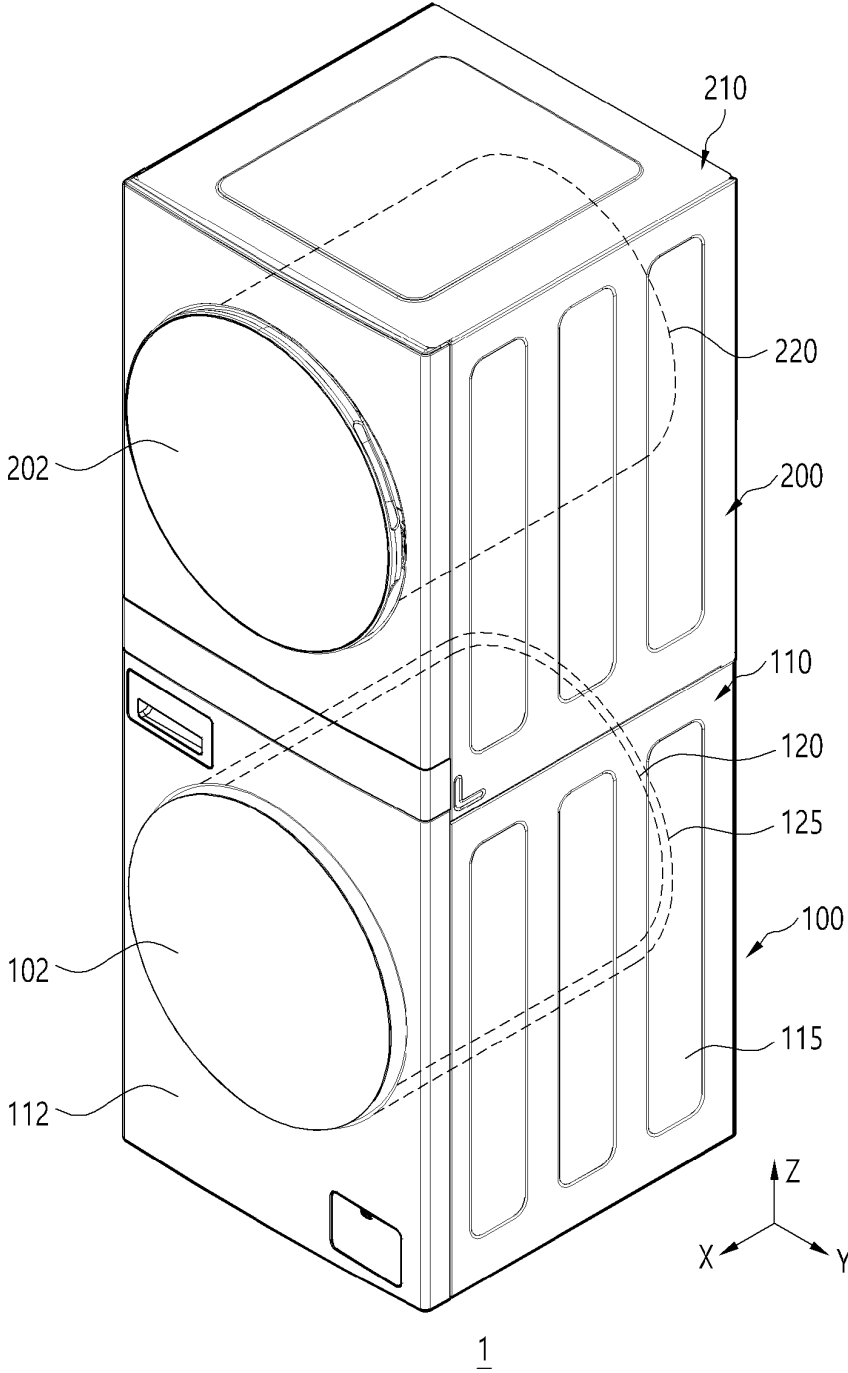

FIG. 4

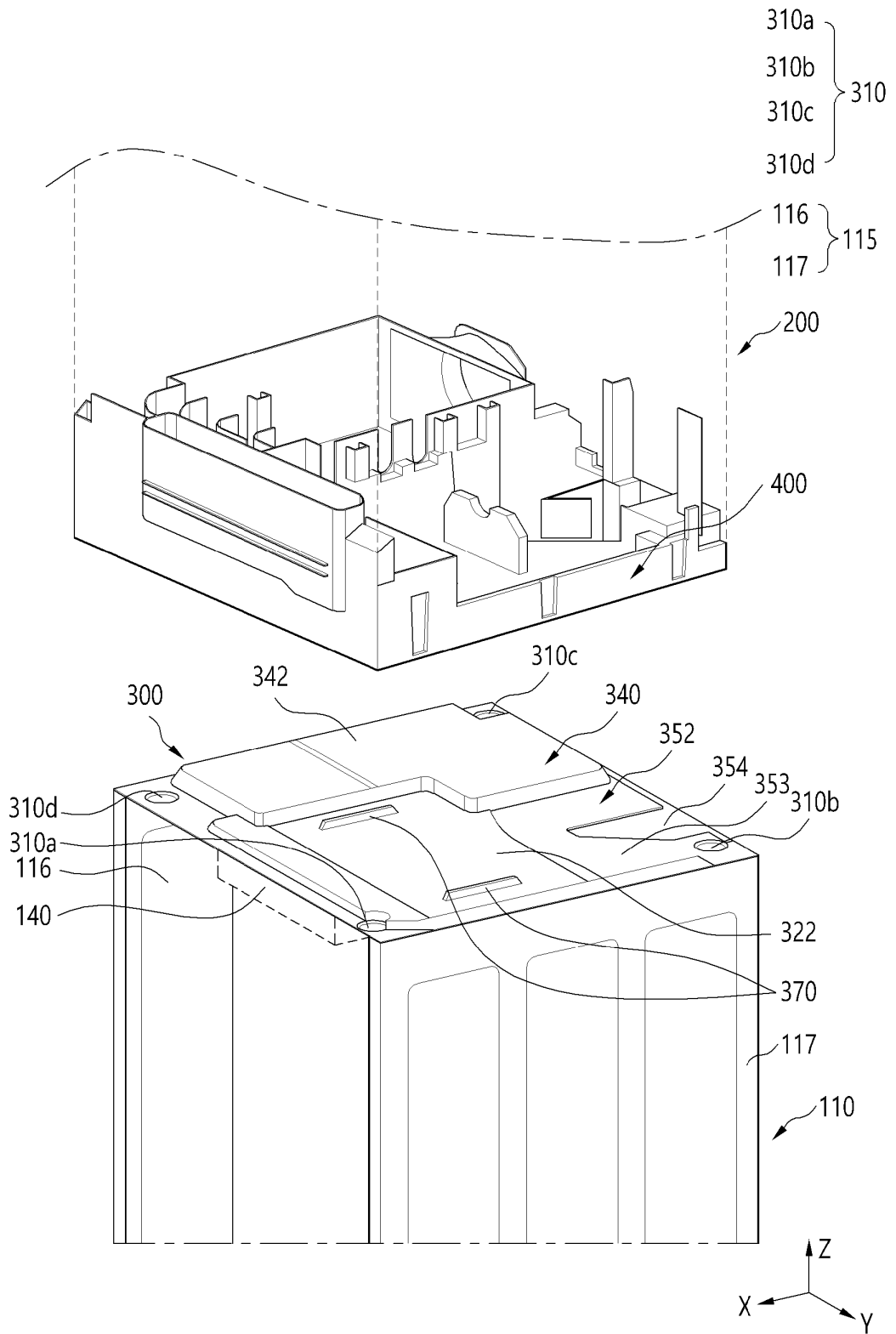

FIG. 5

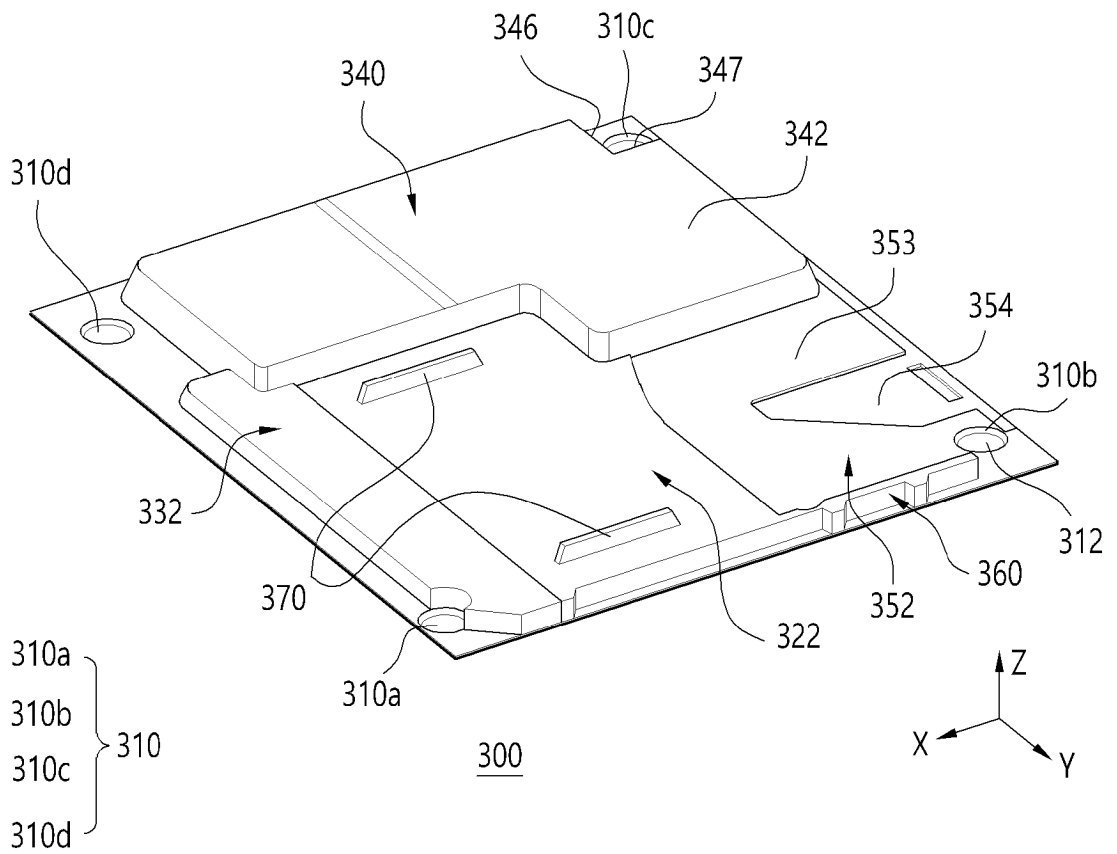

FIG. 6

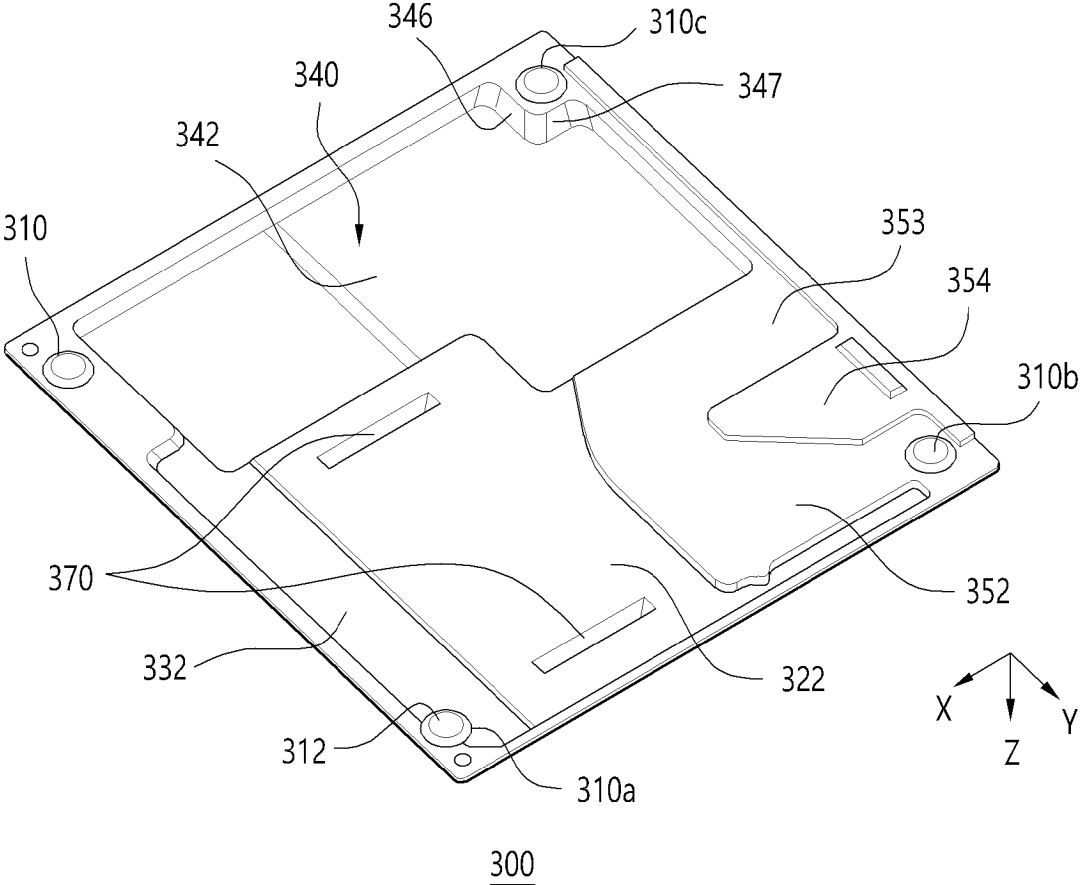

FIG. 7

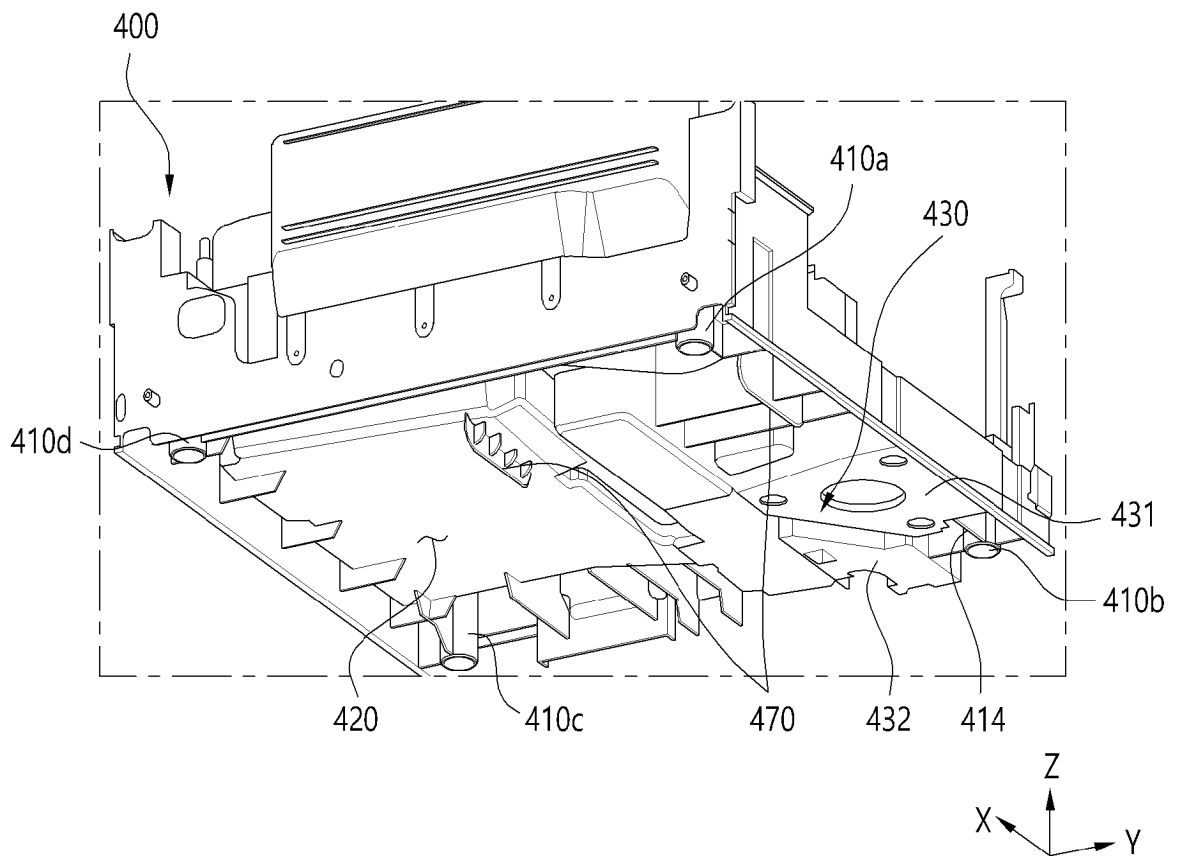

FIG. 8

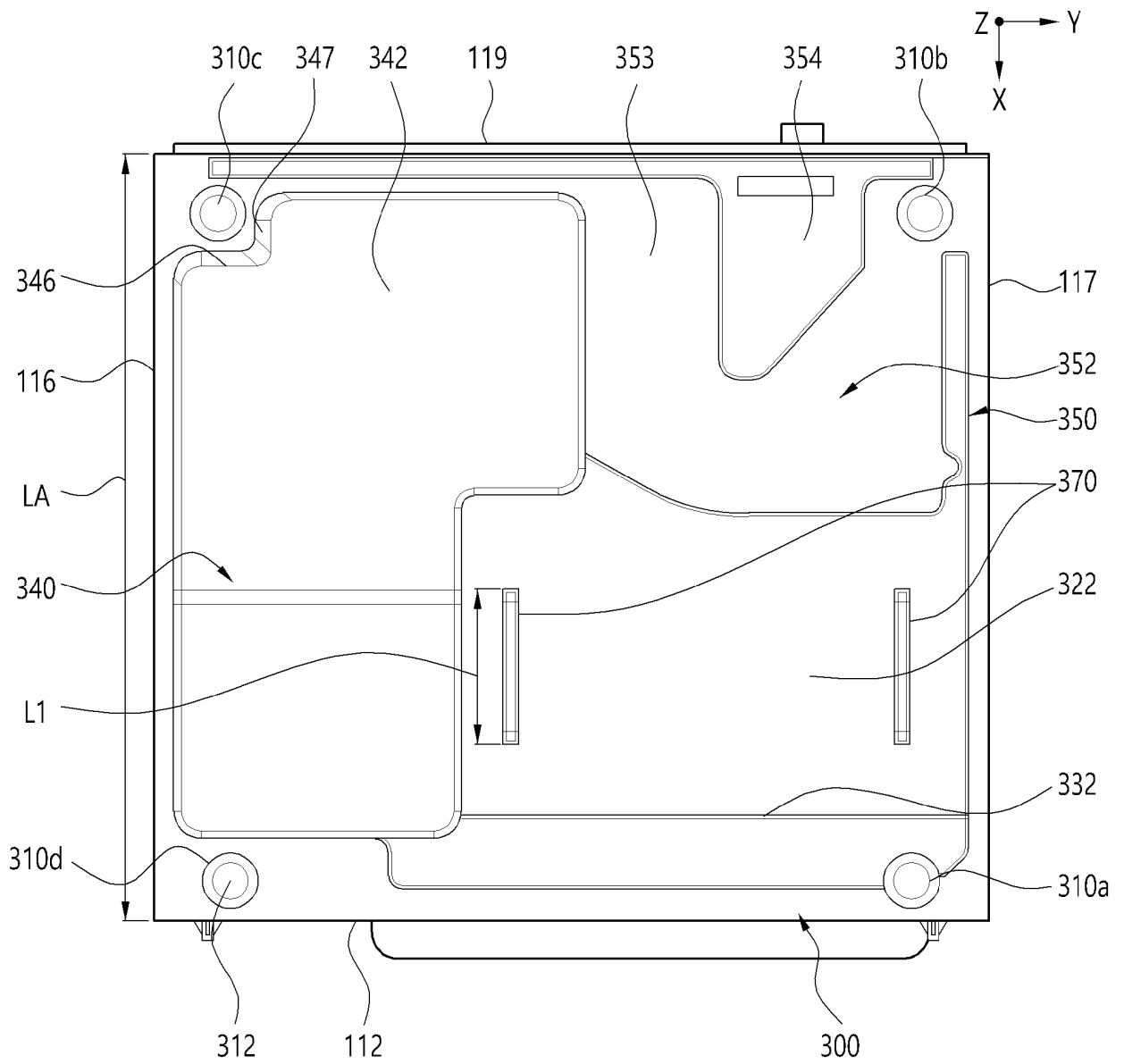

FIG. 9

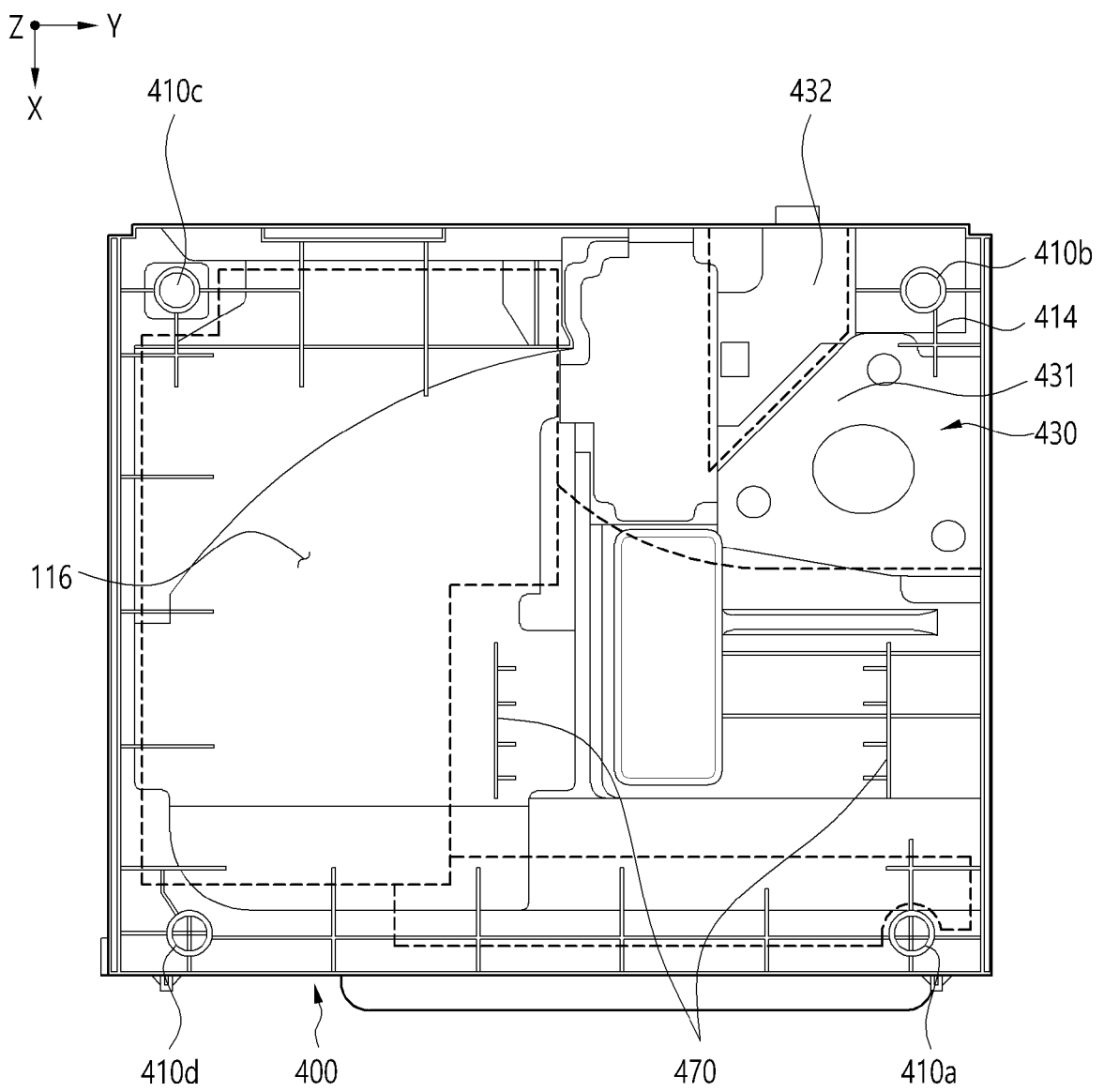

FIG. 10

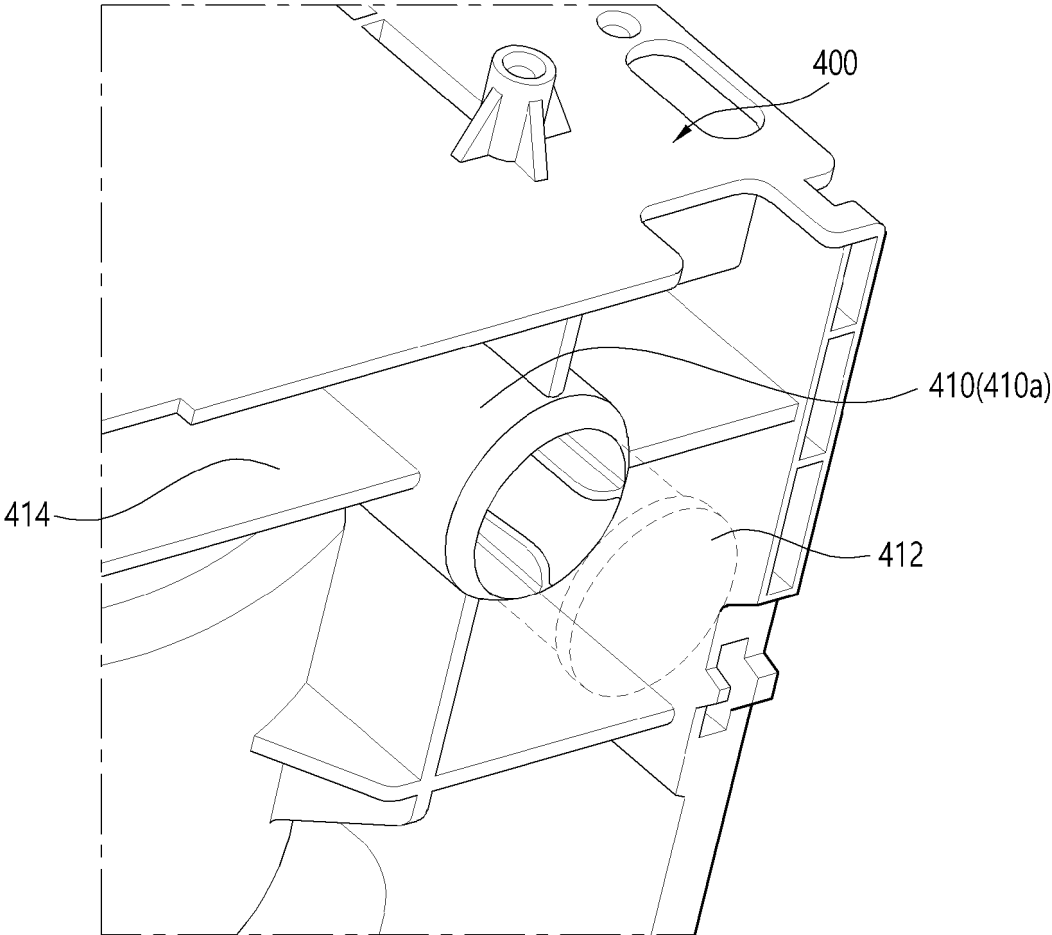

FIG. 11

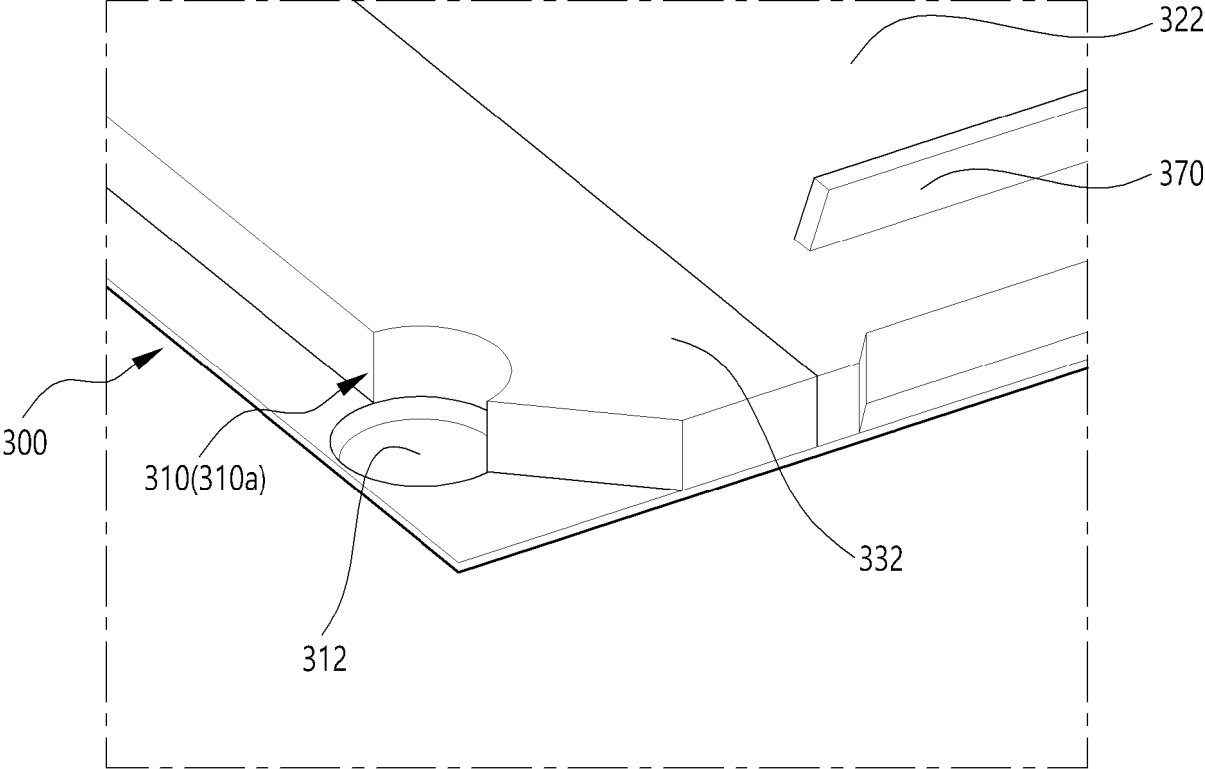

FIG. 12

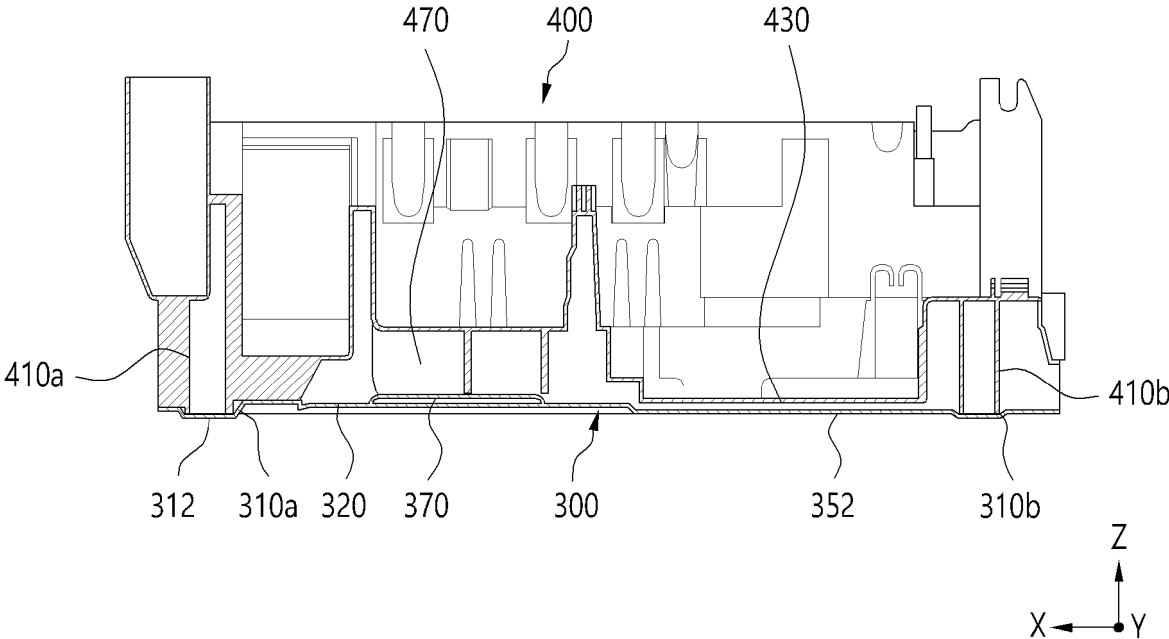

FIG. 13

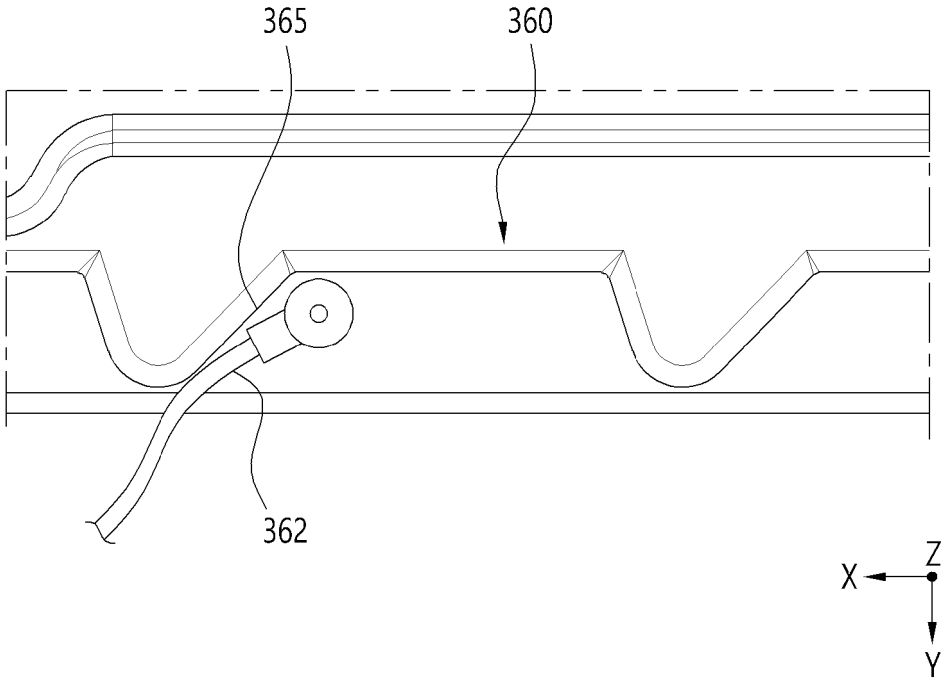

FIG. 14

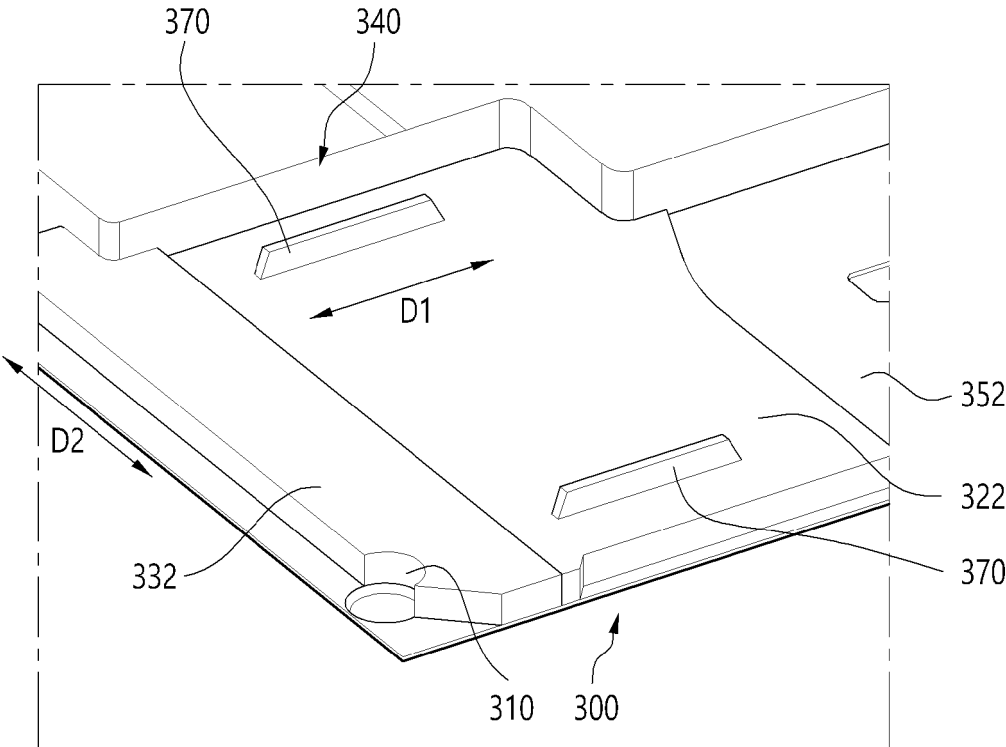

FIG. 15

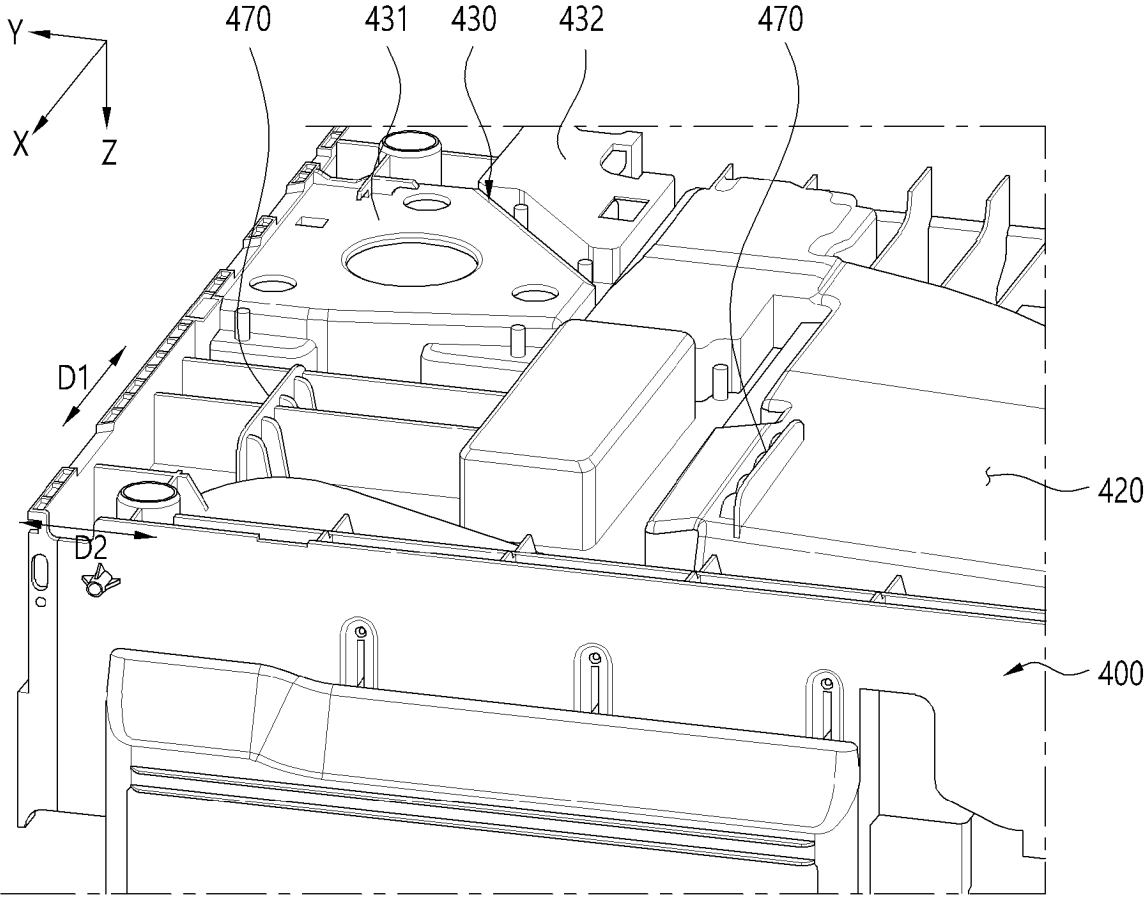

FIG. 16

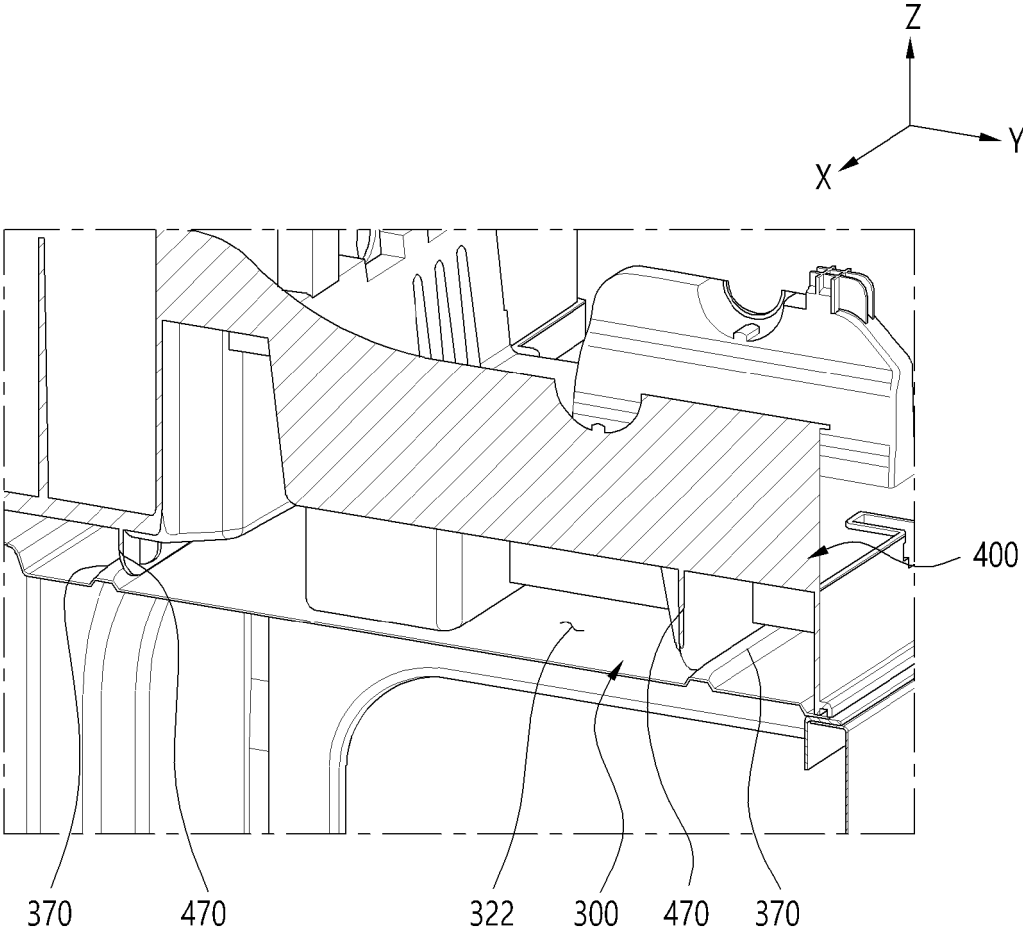

FIG. 17

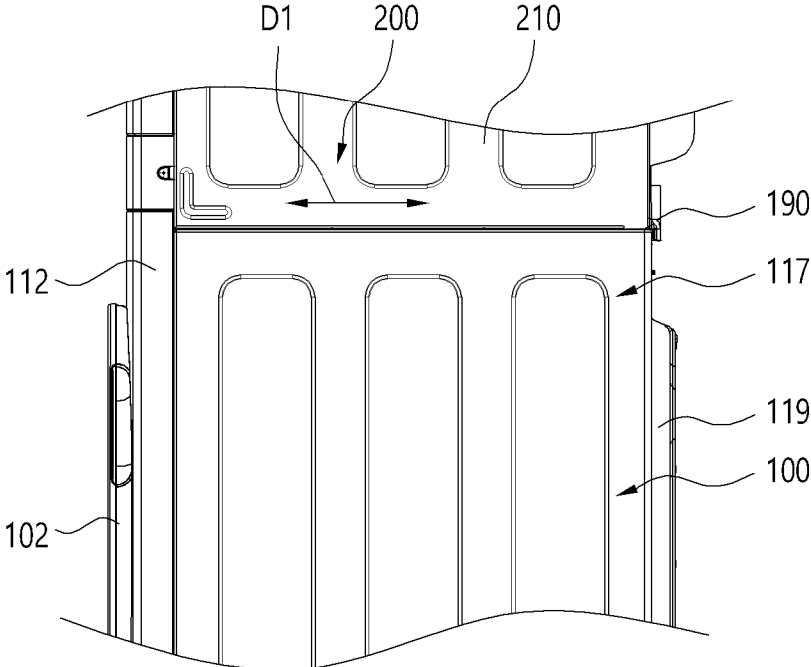

FIG. 18

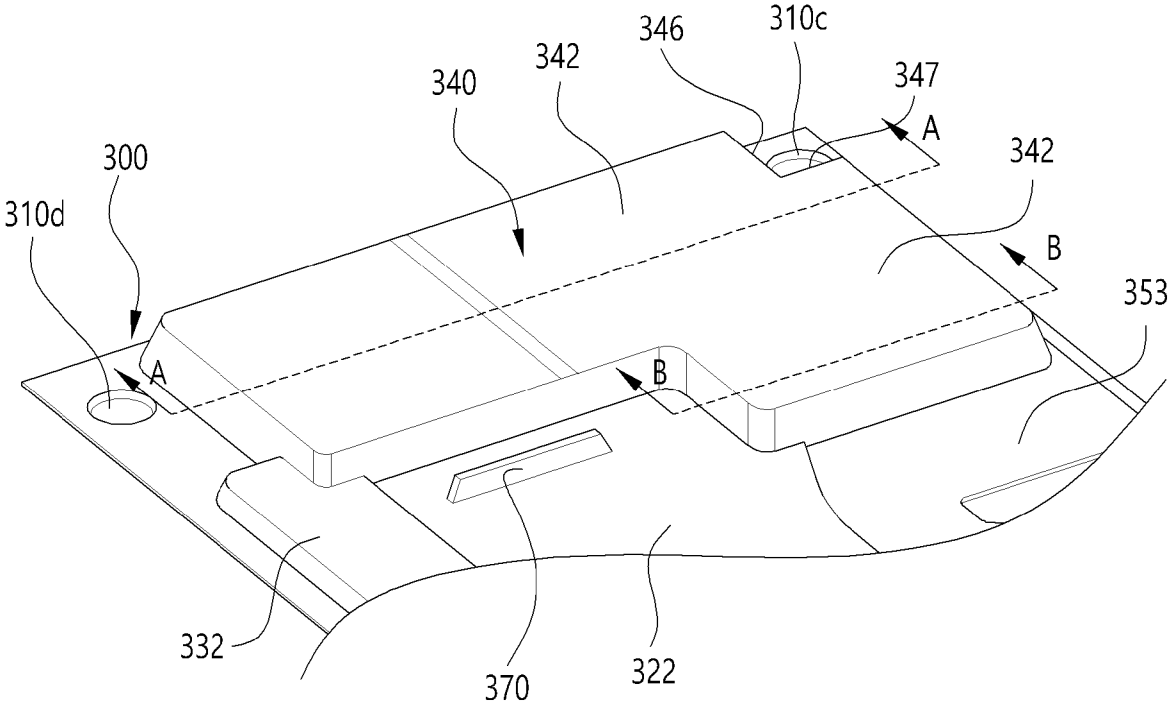

FIG. 19

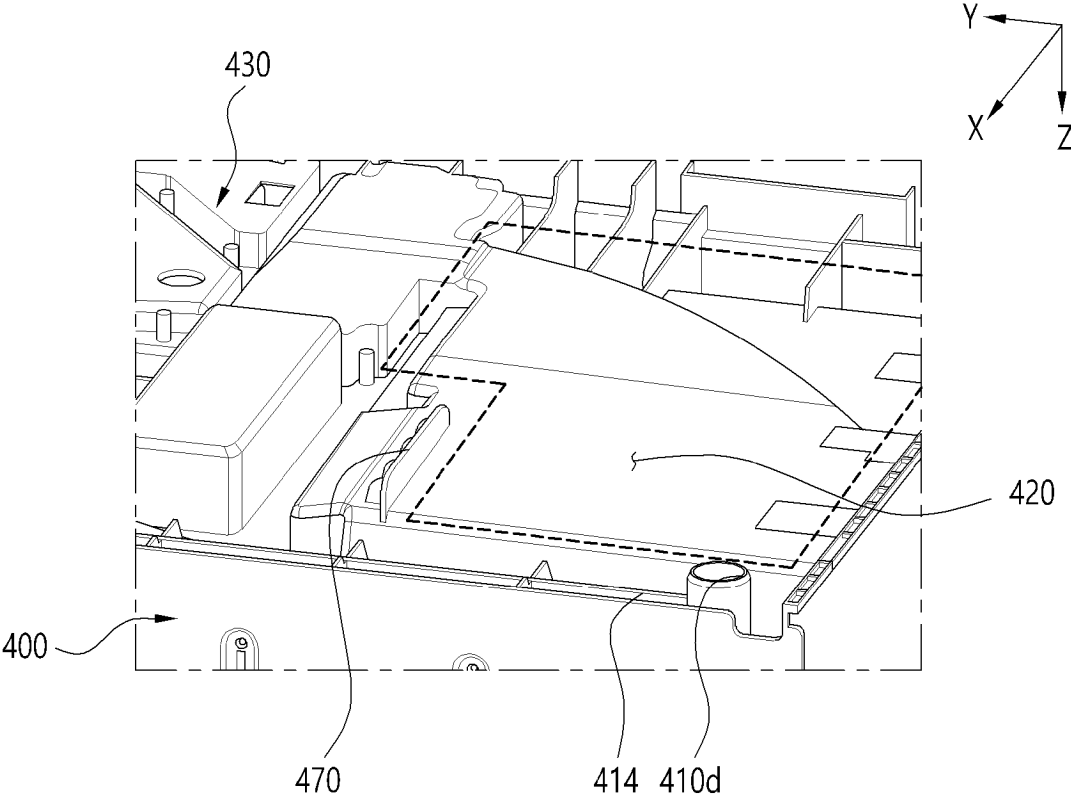

FIG. 20

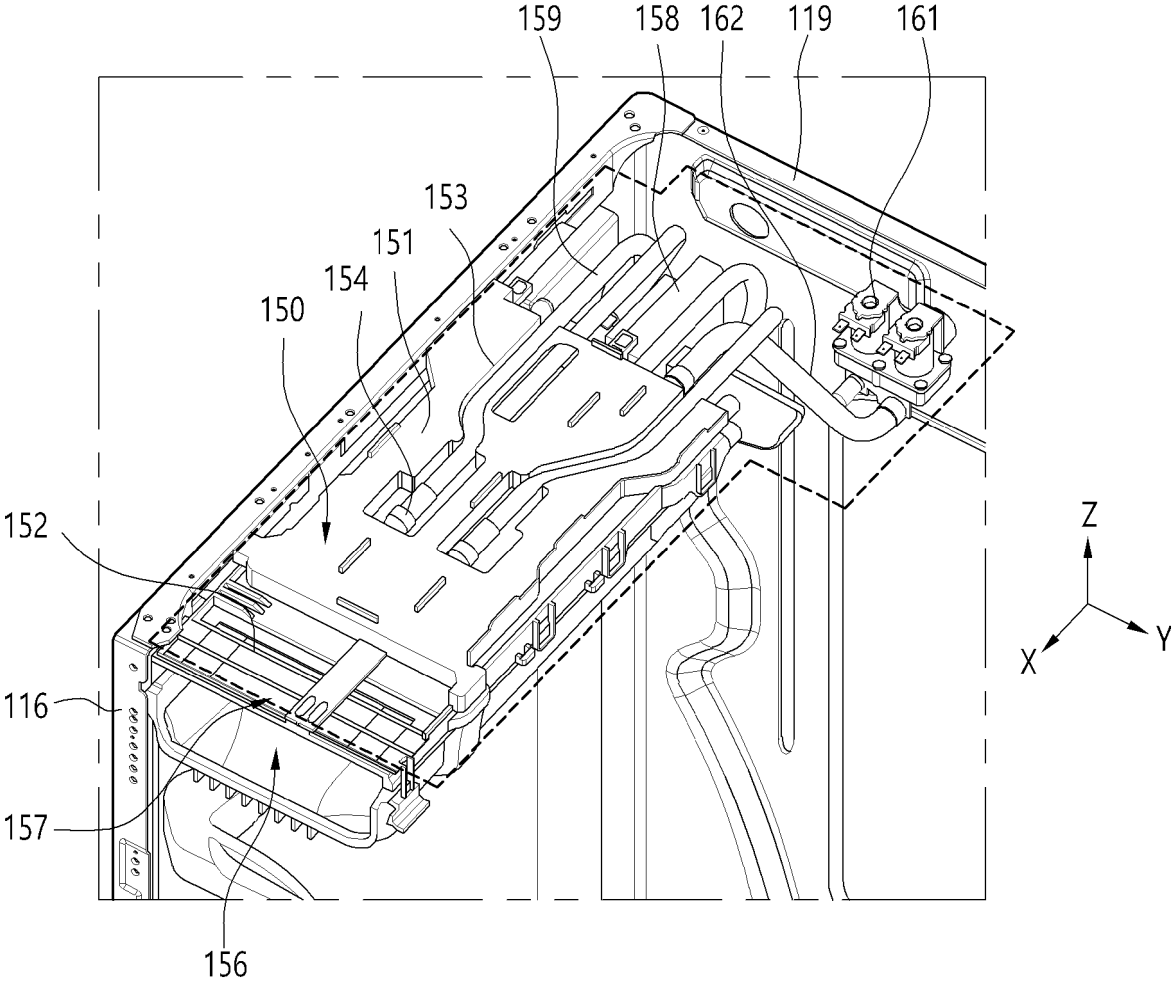

FIG. 21

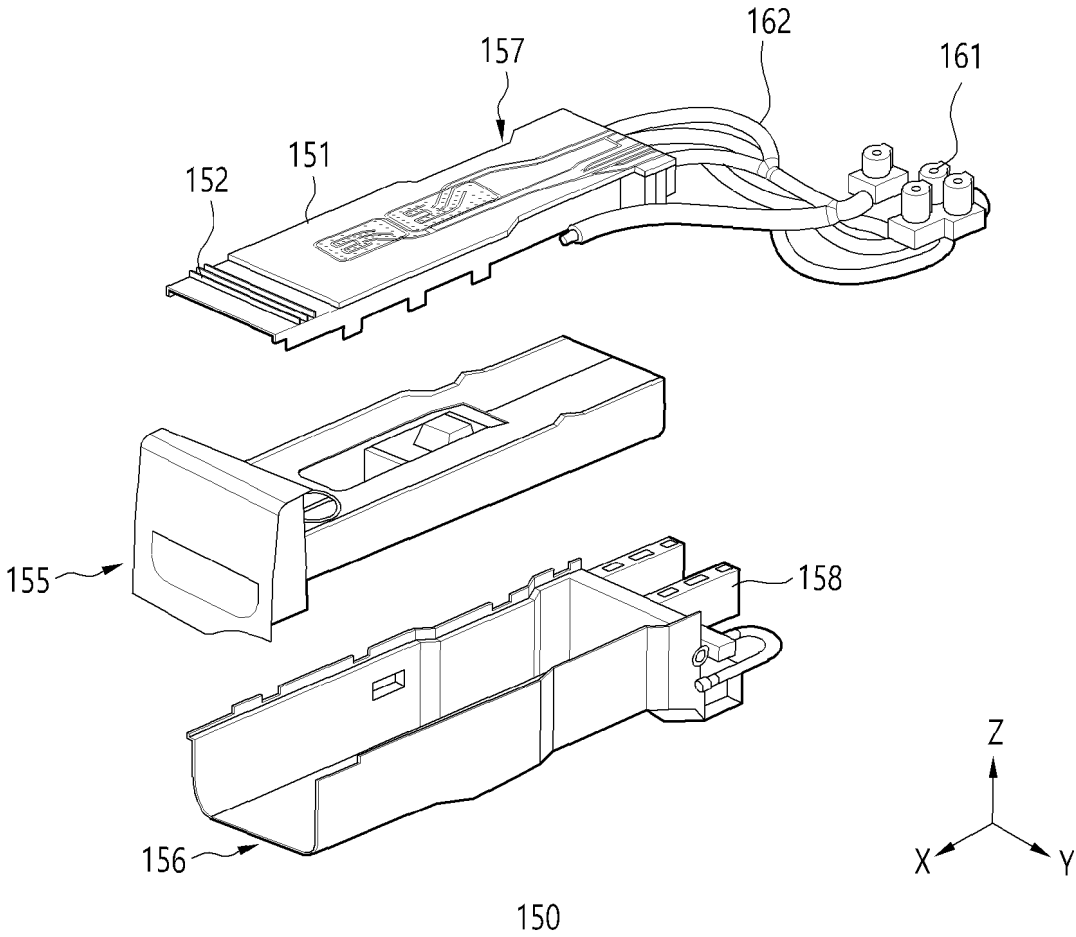

FIG. 22

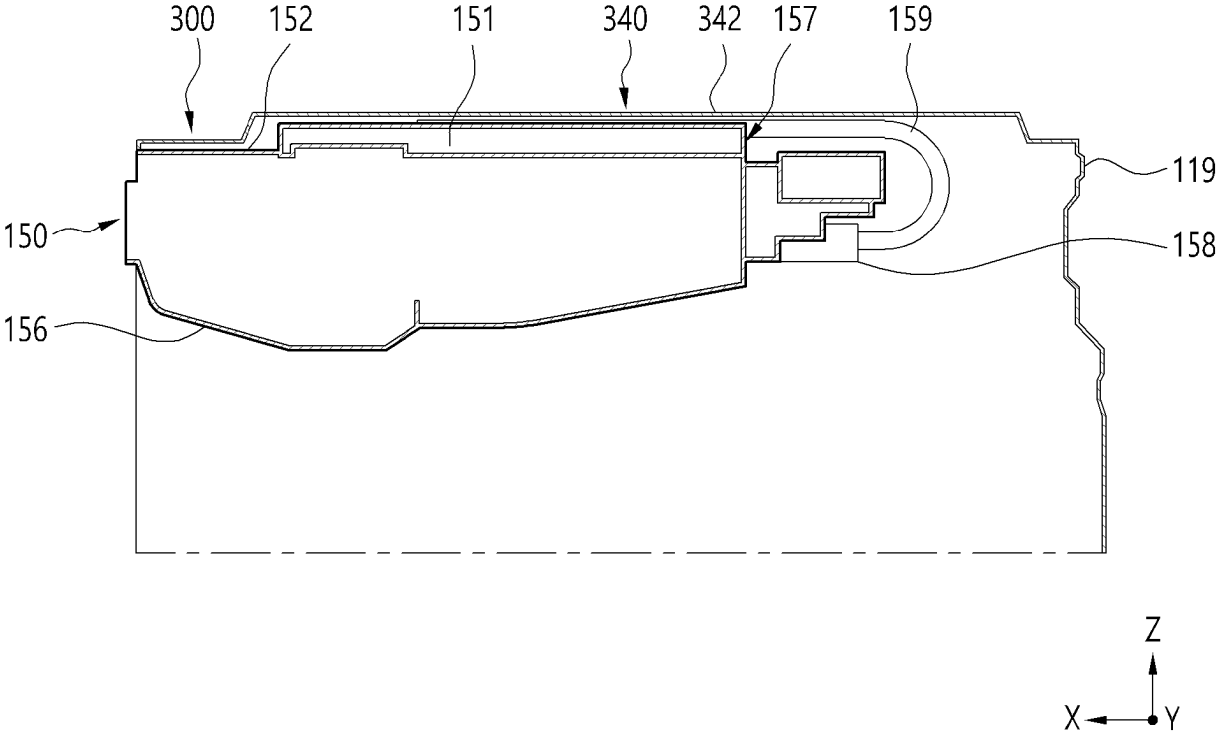

FIG. 23

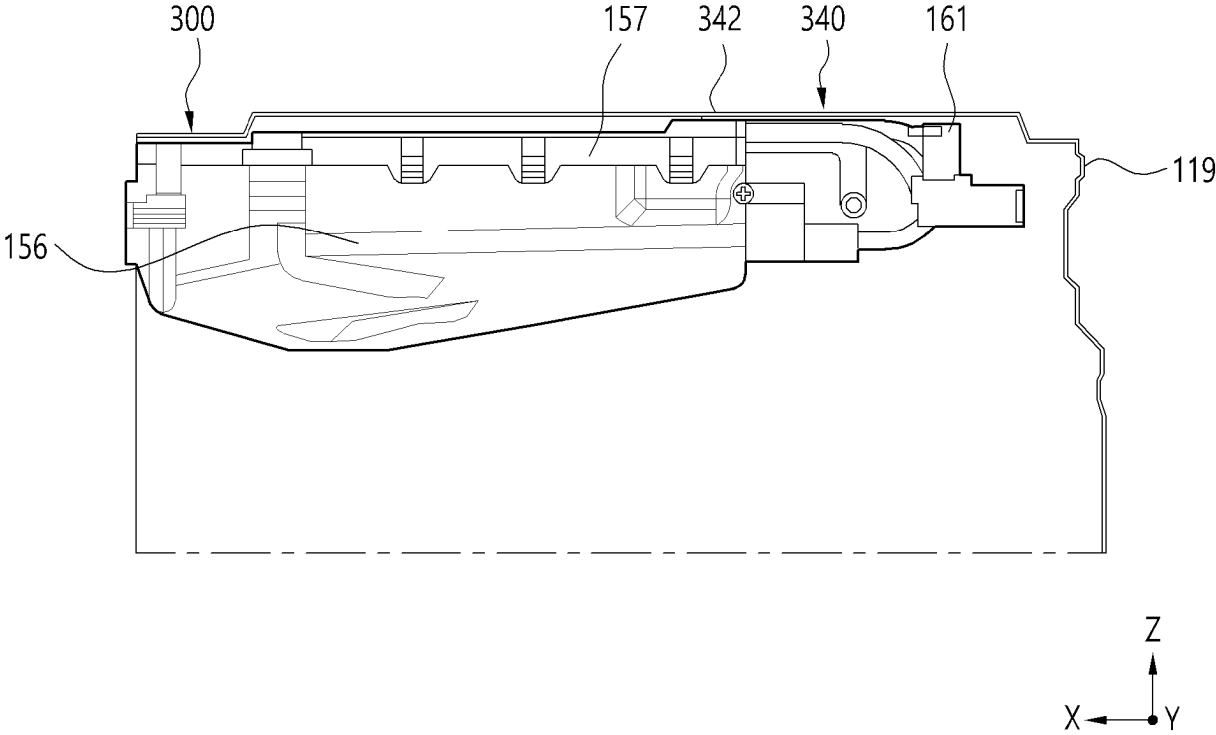

FIG. 24

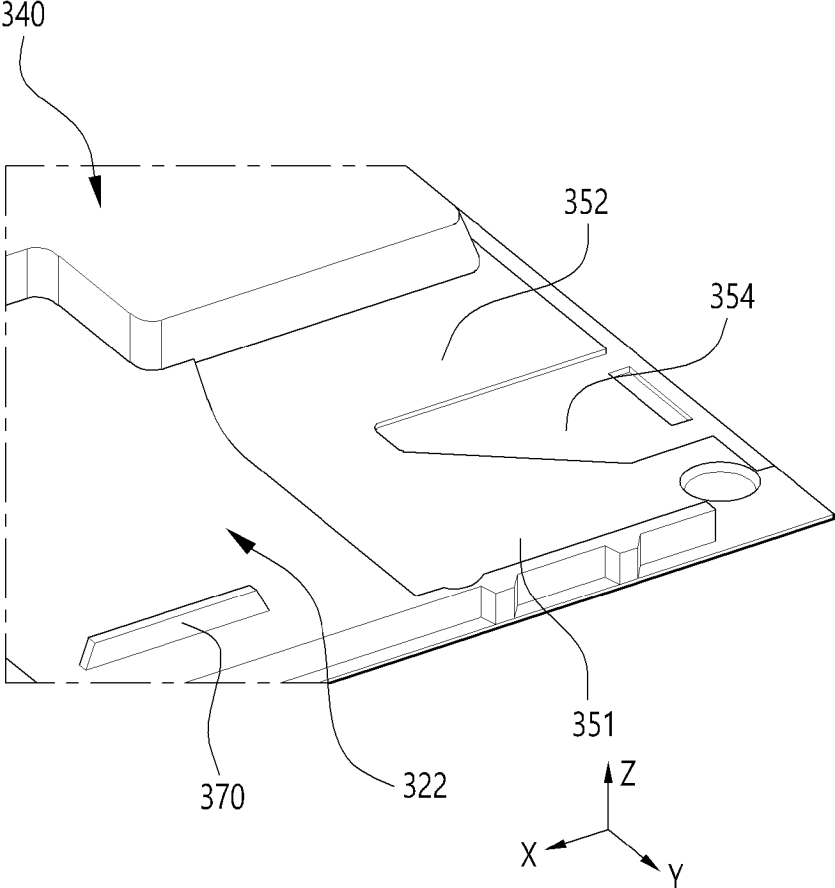

FIG. 25

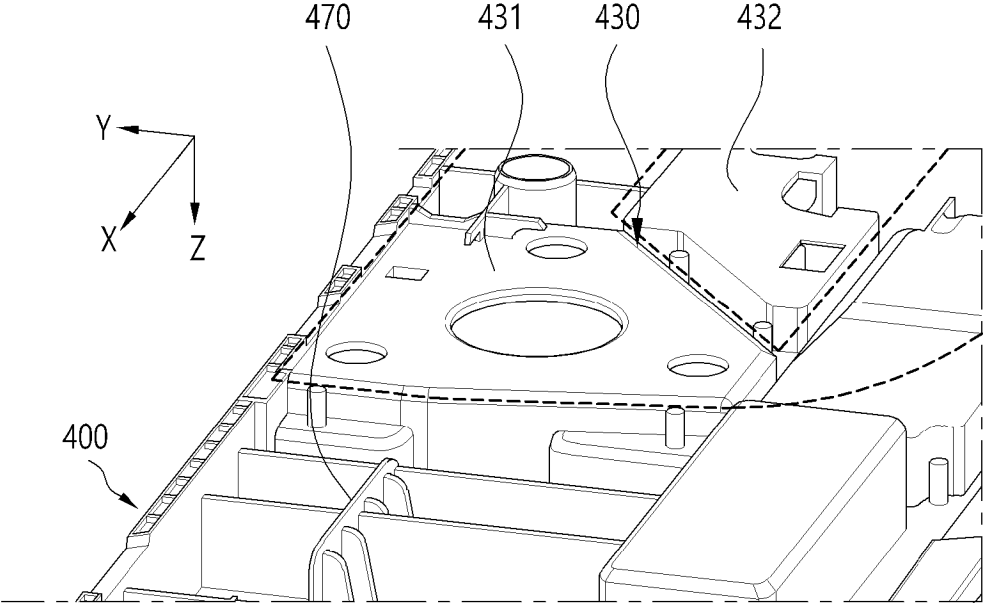
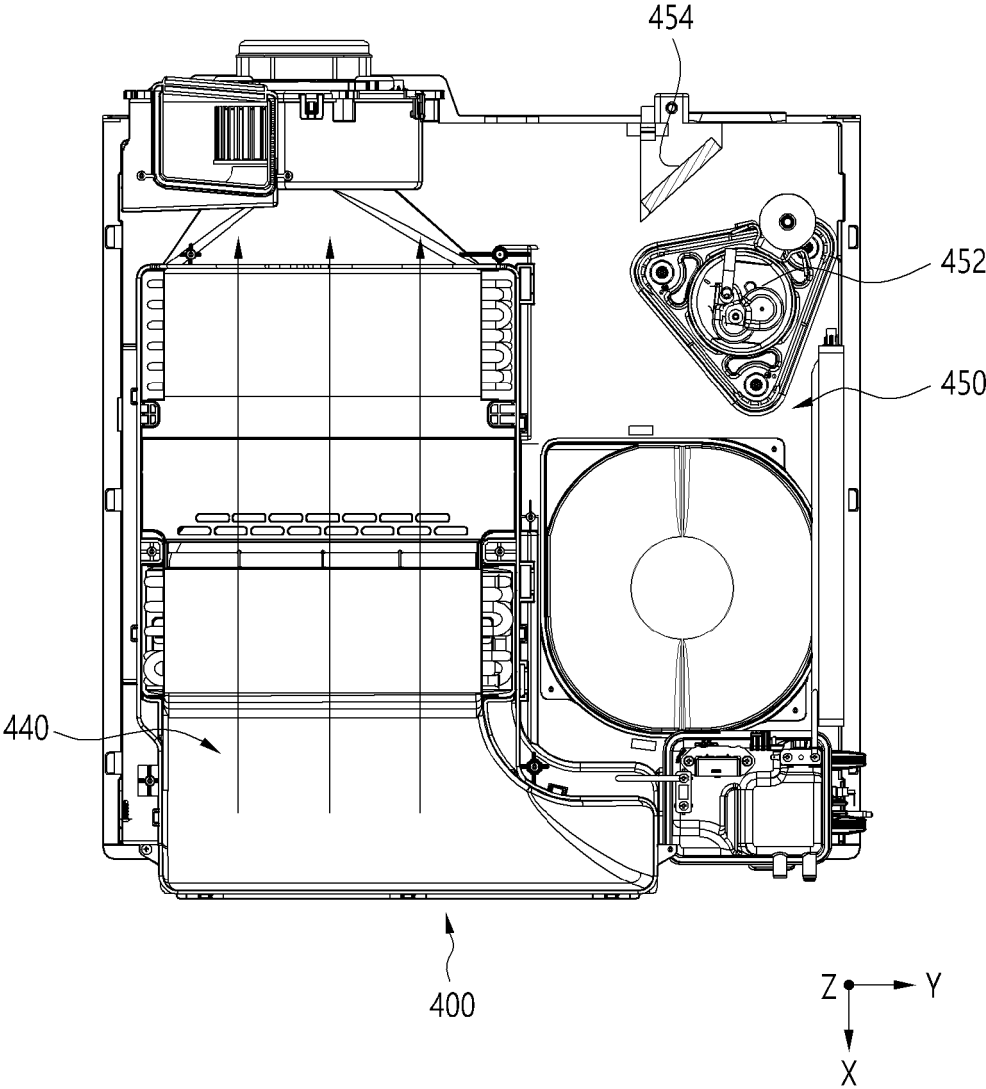

FIG. 26



INTERNATIONAL SEARCH REPORT

International application No.
PCT/KR2023/008290

5

A. CLASSIFICATION OF SUBJECT MATTER
D06F 31/00(2006.01)i; D06F 39/12(2006.01)i; D06F 39/00(2006.01)i; D06F 37/30(2006.01)i; D06F 37/26(2006.01)i; D06F 39/02(2006.01)i
 According to International Patent Classification (IPC) or to both national classification and IPC

10

B. FIELDS SEARCHED

Minimum documentation searched (classification system followed by classification symbols)
 D06F 31/00(2006.01); D06F 34/28(2020.01); D06F 37/26(2006.01); D06F 37/42(2006.01); D06F 39/00(2006.01); D06F 39/02(2006.01); D06F 39/12(2006.01)

15

Documentation searched other than minimum documentation to the extent that such documents are included in the fields searched
 Korean utility models and applications for utility models: IPC as above
 Japanese utility models and applications for utility models: IPC as above

Electronic data base consulted during the international search (name of data base and, where practicable, search terms used)
 eKOMPASS (KIPO internal) & keywords: 적층(stack), 캐비닛(cabinet), 삽입(insertion), 레그(leg), 접지(earth)

20

C. DOCUMENTS CONSIDERED TO BE RELEVANT

Category*	Citation of document, with indication, where appropriate, of the relevant passages	Relevant to claim No.
X	KR 10-2011-0110660 A (LG ELECTRONICS INC.) 07 October 2011 (2011-10-07) See paragraphs [0029]-[0040]; and figures 1-5.	1-4
Y		6-12
A		5,13-23
Y	KR 10-2021-0112852 A (LG ELECTRONICS INC.) 15 September 2021 (2021-09-15) See paragraph [0133]; and figures 4-5.	6-10
Y	KR 10-2007-0001604 A (LG ELECTRONICS INC.) 04 January 2007 (2007-01-04) See paragraph [0092]; and figures 8-9.	10
Y	KR 10-2007-0066606 A (LG ELECTRONICS INC.) 27 June 2007 (2007-06-27) See paragraph [0015]; and figures 1-2.	11-12

40

Further documents are listed in the continuation of Box C. See patent family annex.

* Special categories of cited documents:
 "A" document defining the general state of the art which is not considered to be of particular relevance
 "D" document cited by the applicant in the international application
 "E" earlier application or patent but published on or after the international filing date
 "L" document which may throw doubts on priority claim(s) or which is cited to establish the publication date of another citation or other special reason (as specified)
 "O" document referring to an oral disclosure, use, exhibition or other means
 "P" document published prior to the international filing date but later than the priority date claimed
 "T" later document published after the international filing date or priority date and not in conflict with the application but cited to understand the principle or theory underlying the invention
 "X" document of particular relevance; the claimed invention cannot be considered novel or cannot be considered to involve an inventive step when the document is taken alone
 "Y" document of particular relevance; the claimed invention cannot be considered to involve an inventive step when the document is combined with one or more other such documents, such combination being obvious to a person skilled in the art
 "&" document member of the same patent family

45

Date of the actual completion of the international search **14 September 2023**
 Date of mailing of the international search report **14 September 2023**

50

Name and mailing address of the ISA/KR **Korean Intellectual Property Office
 Government Complex-Daejeon Building 4, 189 Cheongsaro, Seo-gu, Daejeon 35208**
 Facsimile No. **+82-42-481-8578**
 Authorized officer
 Telephone No.

55

INTERNATIONAL SEARCH REPORT

International application No.
PCT/KR2023/008290

5
10
15
20
25
30
35
40
45
50
55

C. DOCUMENTS CONSIDERED TO BE RELEVANT		
Category*	Citation of document, with indication, where appropriate, of the relevant passages	Relevant to claim No.
A	KR 10-2010-0020628 A (DAEWOO ELECTRONICS CORPORATION) 23 February 2010 (2010-02-23) See claim 1; and figure 1.	1-23
.....		

INTERNATIONAL SEARCH REPORT
Information on patent family members

International application No.

PCT/KR2023/008290

5

10

15

20

25

30

35

40

45

50

55

Patent document cited in search report	Publication date (day/month/year)	Patent family member(s)	Publication date (day/month/year)
KR 10-2011-0110660 A	07 October 2011	CA 2735757 A1	01 October 2011
		CA 2735757 C	13 May 2014
		US 2011-0241501 A1	06 October 2011
		US 8672426 B2	18 March 2014
KR 10-2021-0112852 A	15 September 2021	CN 113355884 A	07 September 2021
		EP 3875660 A1	08 September 2021
		KR 10-2023-0015492 A	31 January 2023
		KR 10-2493056 B1	30 January 2023
		US 2021-0277581 A1	09 September 2021
KR 10-2007-0001604 A	04 January 2007	DE 102006029661 A1	01 February 2007
		KR 10-1155481 B1	15 June 2012
		KR 10-1155482 B1	15 June 2012
		KR 10-1155483 B1	15 June 2012
		KR 10-1203553 B1	21 November 2012
		KR 10-2007-0001601 A	04 January 2007
		KR 10-2007-0001602 A	04 January 2007
		KR 10-2007-0001603 A	04 January 2007
		US 2007-0056330 A1	15 March 2007
KR 10-2007-0066606 A	27 June 2007	None	
KR 10-2010-0020628 A	23 February 2010	None	

Form PCT/ISA/210 (patent family annex) (July 2022)

REFERENCES CITED IN THE DESCRIPTION

This list of references cited by the applicant is for the reader's convenience only. It does not form part of the European patent document. Even though great care has been taken in compiling the references, errors or omissions cannot be excluded and the EPO disclaims all liability in this regard.

Patent documents cited in the description

- KR 1020080021921 A1 [0010]